

Proposed Geo-Location Amendment

IEEE P802.22 Wireless RANs

Date: 2011-05-04

Authors:

Name	Company	Address	Phone	email
Russ Markovsky	InvisiTrack, Inc.		(410) 991-8529	rmark@invisitrack.com
Upkar Dhaliwal	InvisiTrack, Inc		(858) 926-5839	upkar@invisitrack.com

Notice: This document has been prepared to assist IEEE 802.22. It is offered as a basis for discussion and is not binding on the contributing individual(s) or organization(s). The material in this document is subject to change in form and content after further study. The contributor(s) reserve(s) the right to add, amend or withdraw material contained herein.

Release: The contributor grants a free, irrevocable license to the IEEE to incorporate material contained in this contribution, and any modifications thereof, in the creation of an IEEE Standards publication; to copyright in the IEEE's name any IEEE Standards publication even though it may include portions of this contribution; and at the IEEE's sole discretion to permit others to reproduce in whole or in part the resulting IEEE Standards publication. The contributor also acknowledges and accepts that this contribution may be made public by IEEE 802.22.

Patent Policy and Procedures: The contributor is familiar with the IEEE 802 Patent Policy and Procedures <http://standards.ieee.org/guides/bylaws/sb-bylaws.pdf> including the statement "IEEE standards may include the known use of patent(s), including patent applications, provided the IEEE receives assurance from the patent holder or applicant with respect to patents essential for compliance with both mandatory and optional portions of the standard." Early disclosure to the Working Group of patent information that might be relevant to the standard is essential to reduce the possibility for delays in the development process and increase the likelihood that the draft publication will be approved for publication. Please notify the Chair **Apurva Mody** <apurva.mody@ieee.org> as early as possible, in written or electronic form, if patented technology (or technology under patent application) might be incorporated into a draft standard being developed within the IEEE 802.22 Working Group. **If you have questions, contact the IEEE Patent Committee Administrator at patcom@iee.org.**

Abstract

This presentation describes proposed enhancements to the most recently approved version of the IEEE 802.22 standards. The presentation will also demonstrate how the proposed enhancements can support advanced geo-location techniques for determining location in difficult indoor environments.

Precision Indoor Location:

The InvisiTrack Solution

Presented to 802.22 Group

May 5, 2011

InvisiTrack Solution Overview

- **Developed for indoor and challenging outdoor environments**
 - Dense multipath environment
- **Low computational intensity multipath mitigation algorithms**
 - Can be executed in software by a nomadic CPE/ mobile terminal
- **Developed for mobile environment**
 - Allows simultaneous tracking of several hundred terminals
- **Supports one-way and transponder distance measurements**
- **Same multipath mitigation can be used for determining DLLOS distance and DOA/ AOA (direction/ angle of arrival)**
 - Supports geo-location by a single position reference (e.g. BS or CPE)
- **Compatible with the existing IEEE 802.22 Standard protocols/ infrastructure**
 - No changes in HW required
 - No changes in PHY

Suggested Amendment: Transponder Mode Option

Existing 802.22 Geo-Location Capability

- **Geo-Locate over long distances**
 - **Needs Base Station**
 - **Relies on one way OFDM coherency**
 - **(Coherency affected by multipath)**

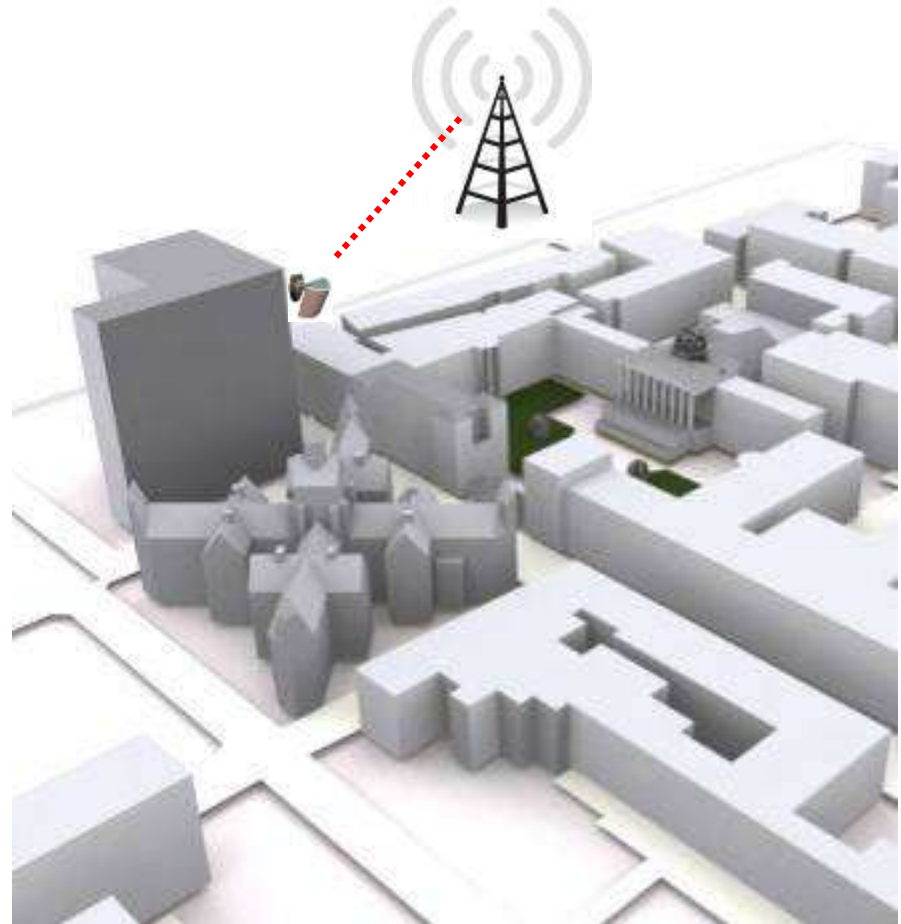

Addendum 802.22 Geo-Location capability (Transponder Mode)

- **Improved Indoor closer range Accuracy**
 - Does not rely on OFDM system coherency.
 - Either a terminal or base station/ fixed CPE will originate the ranging signal (fully compatible with the 802.22 signaling, e.g. OFDM)
 - The receiving terminal will then store the DFT output (samples) and, will re-transmit (repeat) the ranging signal from the stored DFT samples.

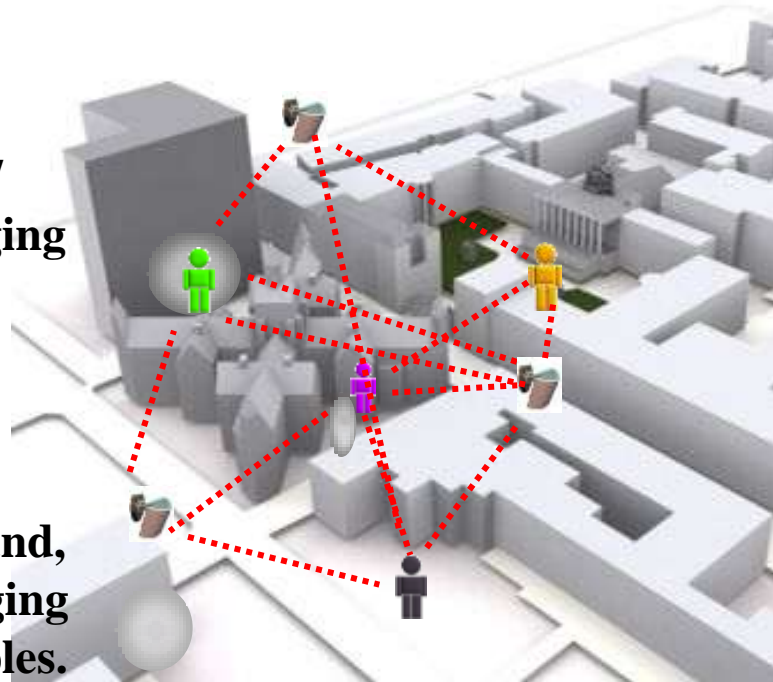

Transponder Mode, continued

IEEE 802.22 – Frame Structure

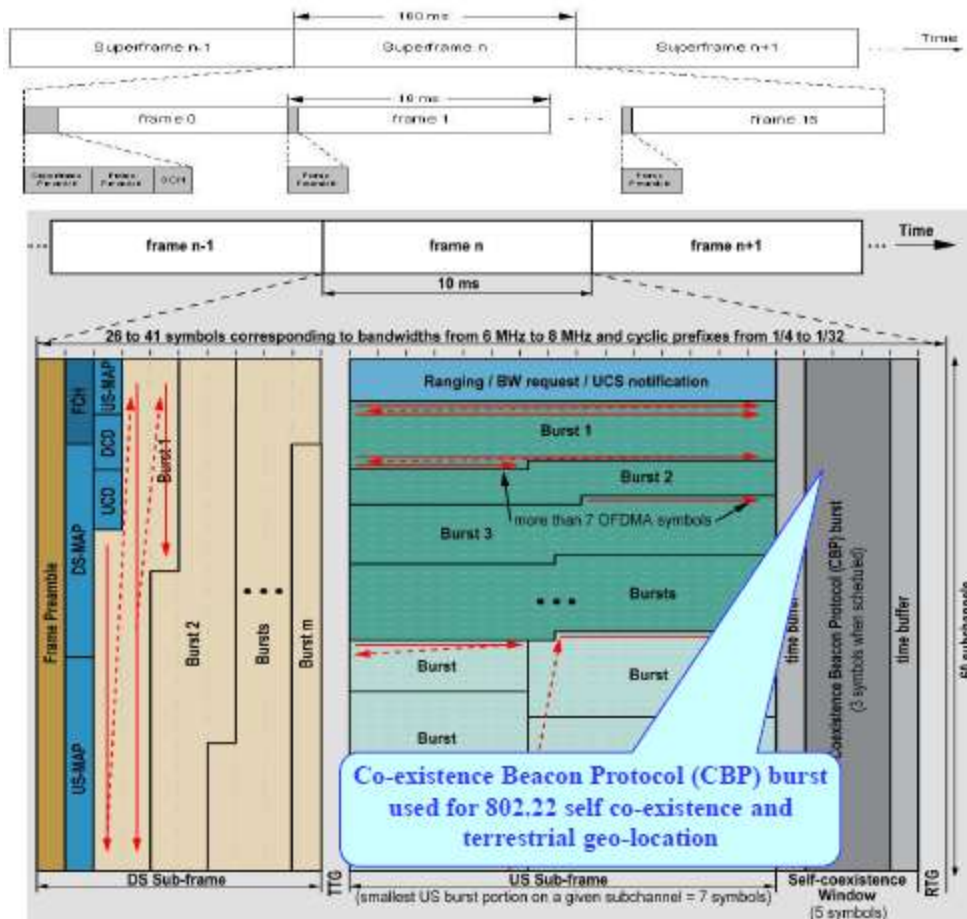

- 802.22 supports **Time Division Duplex (TDD)** frame structure
- **Super-frame: 160 ms, Frame: 10 ms**
 - Each frame consists of **downlink (DL) sub-frame, uplink (UL) sub-frame, and the Co-existence Beacon Protocol (CBP) burst**
 - Lengths of DL and UL sub-frames can be adjusted.
- **Self Co-existence Window:** BS commands subscribers to send out CBPs for 802.22
 - self co-existence – CBP bursts contain information about the backup channel sets and sensing times
 - terrestrial geo-location and
 - whitespace device identification as required by the regulatory domain rules.

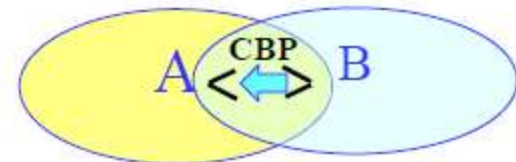

The InvisiTrack Approach to Terrestrial Geo-Location

Greater Accuracy

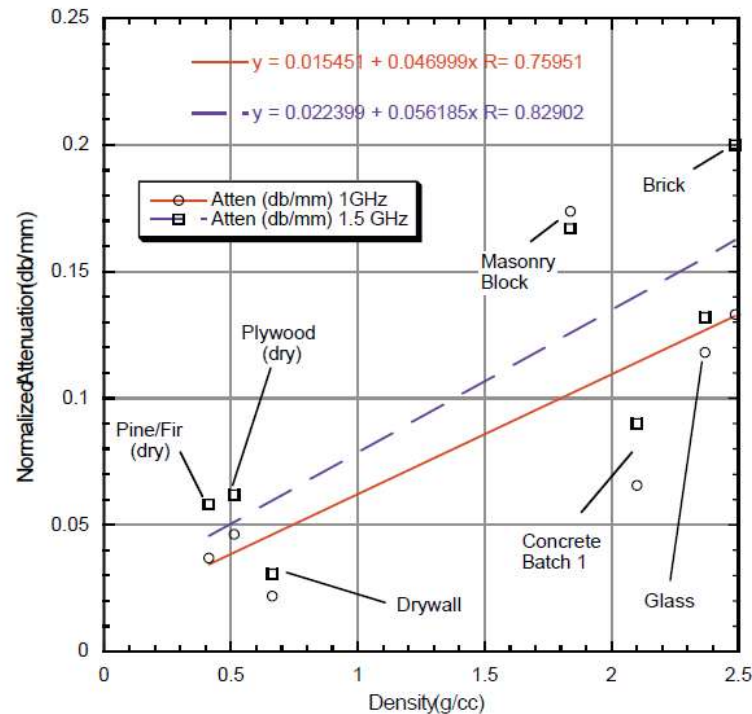

Figure 5.2: Signal loss per unit material thickness (expressed in dB/mm) as a function of the material density (g/cc). The above data represent a very small sampling of the available database at only two discrete frequencies. Attenuation increases, generally, with increasing signal frequency.

Indoor Location - Unique Challenges

- **Obstructed/Non-Line-of-Sight Environment**
 - DLOS (Direct Line Of Site) Blockage
 - Structures, walls, floors, etc.
 - Requires signals that penetrate dielectrics
 - DLOS signal is severely attenuated relative to reflected signals

- **Dispersive Propagation Environment**
 - Multipath Interference
 - DLOS and reflections are closely spaced
 - Requires signal structure to minimize effect

Signal Propagation - Background

- **Signal penetration in dielectric**
 - Loss varies as square root of wavelength
 - Lower frequencies penetrate better than higher
 - Example: with the same loss, 240 MHz penetrates 3.2 times further than 2.4 GHz or, at same distance, loss at 2.4 GHz is 10 dB greater.
 - Dispersion (multipath): inversely proportional to wavelength
 - Objects smaller than the wavelength don't reflect;
 - Objects larger than the wavelength, reflect and generate multipath dispersion.

InvisiTrack Solution Integration

- **InvisiTrack's geolocation ranging signal is < 5 MHz BW (ie, does not require channel bonding).**
- **The ranging signal consists of:**
 - Pilot signals or subcarrier signals; or
 - A combination of pilots and subcarriers;
 - The total number of signals is 100 or less.
- **The ranging signal subcarriers do not need to be modulated; the modulation may also be applied, for example QPSK, as long as the modulation signal is known beforehand.**

InvisiTrack Multipath Processor

- **Uses highly optimized and improved high-resolution spectrum estimation analysis methods and techniques as applicable to multipath mitigation;**
 - Able to separate direct path for accurate range estimation
 - Performance
 - No “picket fence” effect
- **Methods and techniques support frequency estimations that approach the Cramer-Rao Bound (CRB).**

High-Resolution Spectrum Estimation Analysis Concept

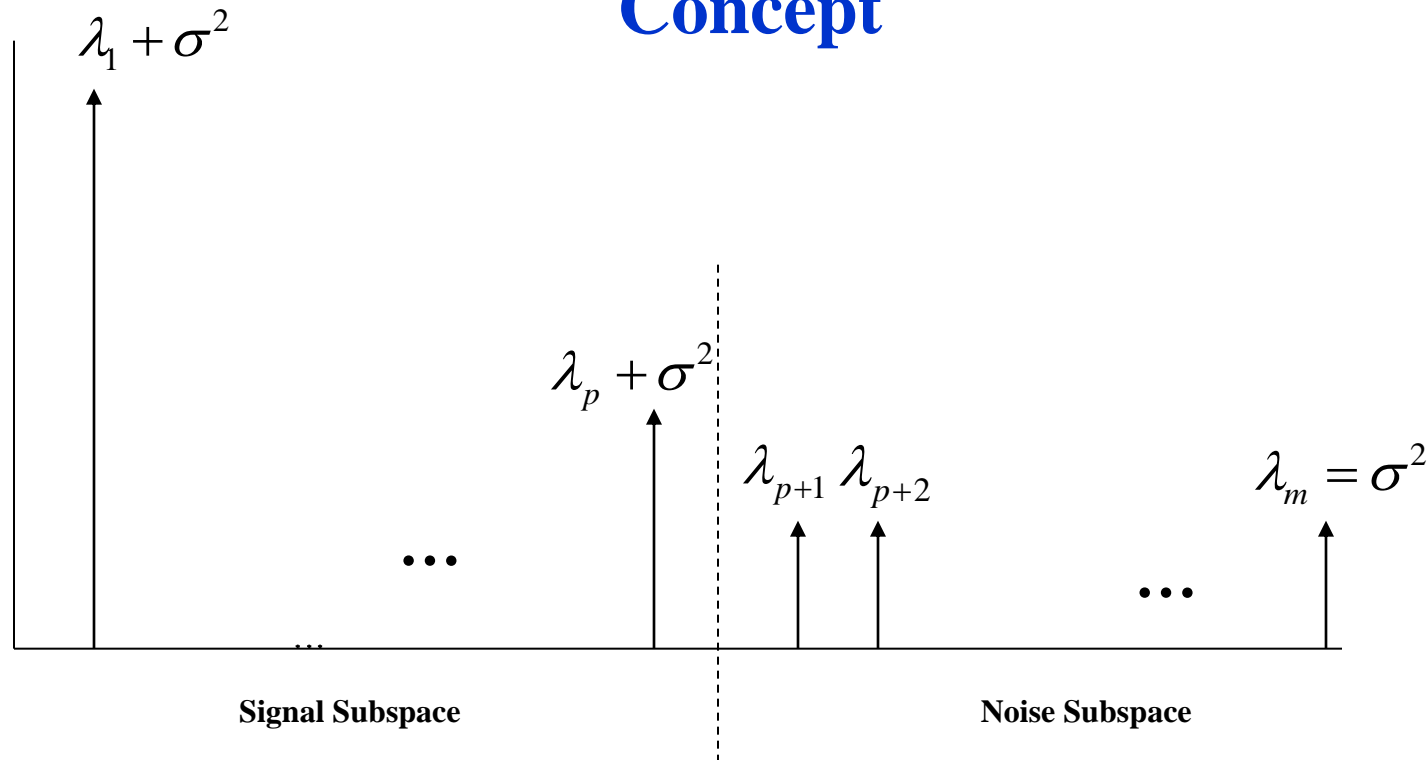

Signal Subspace – Eigenvectors Associated with Largest Eigenvalues

Signal Subspace – the Direct Path Plus Reflected Signals

Noise Subspace – Eigenvectors Associated with m-p Smallest Eigenvalues

Noise Subspace – Additive Noise

InvisiTrack Solution Integration

- Can be seamlessly integrated into the current 802.22 geolocation model – uses complex channel impulse response in the frequency domain

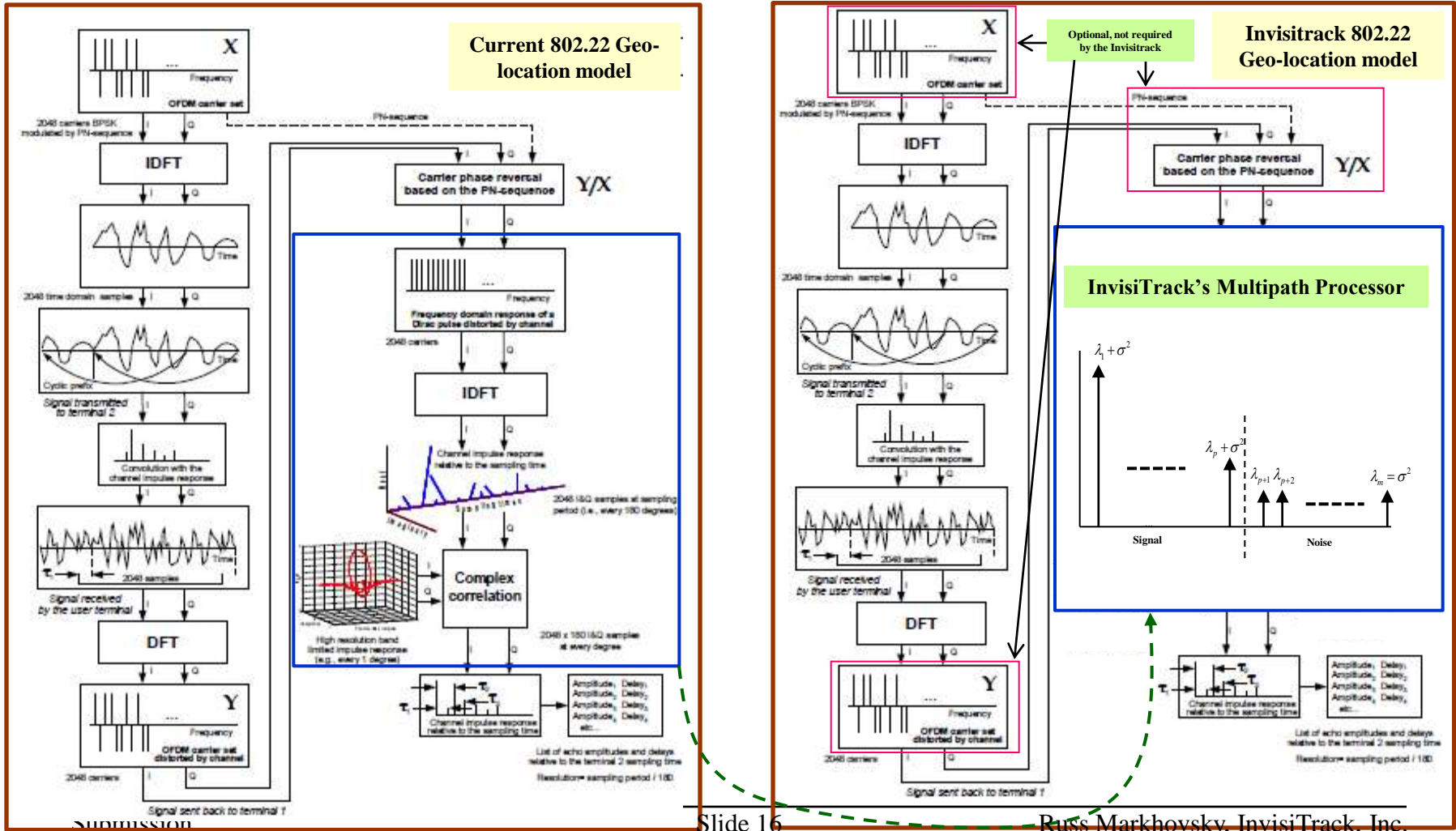

InvisiTrack Geo-location Results

- **Developed mobile, battery-operated proof of concept:**
 - Dimensions: 3x4x2 inches
 - Operating frequencies: VHF (High-band)
 - Operating bandwidth: 5 MHz
- **In all tests TX and RX antennas heights were between 0.5 meters to 1.5 meters from the ground .**



InvisiTrack Geolocation Results

Environment	Range (m)	Accuracy (m), ≥67% confidence	Accuracy (m), ≥95% confidence	Comments
Coaxial cables	500 (equiv)	N/A	0.5	With multipath simulator
Analog Proof of Concept Devices				
Outdoor	350	2	3	Suburban setting
Difficult Indoor	125	4	8	Multiple floor buildings
Extreme, Indoor parking	125	4	8	Reinforced Concrete structure
Digital Production Devices				
Outdoor	350	1	2	Suburban setting
Difficult Indoor	125	2	3	Multiple floor buildings
Extreme, Indoor parking	125	2	3	Reinforced Concrete structure

UMBC Field

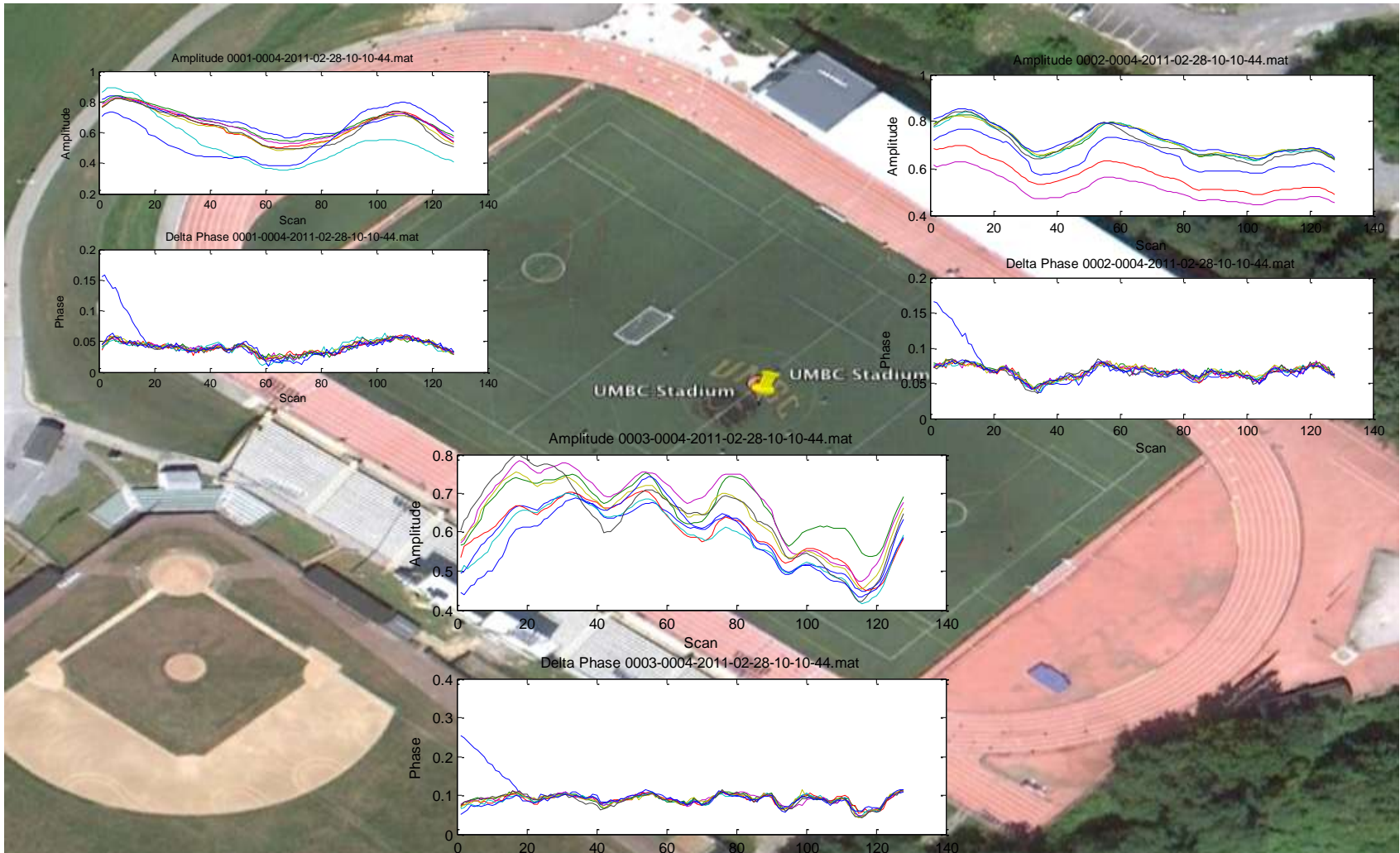

Conversion to Distance

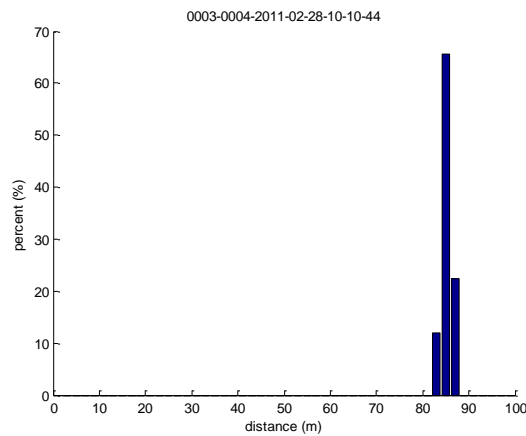
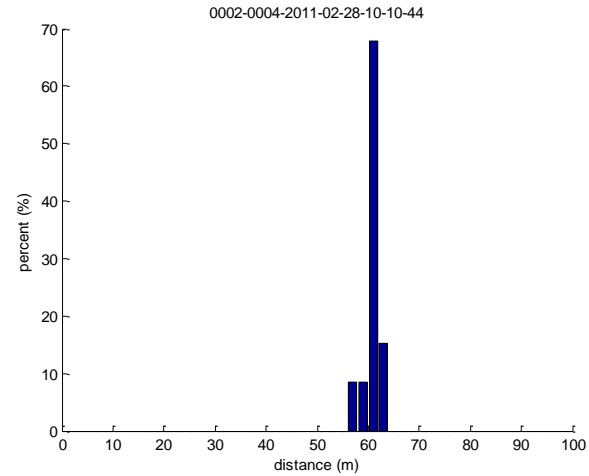
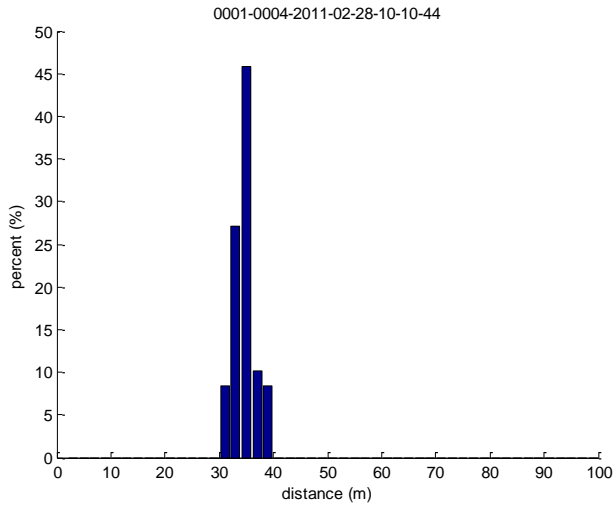

UMBC Field

2011-02-28-10-10-44.mat

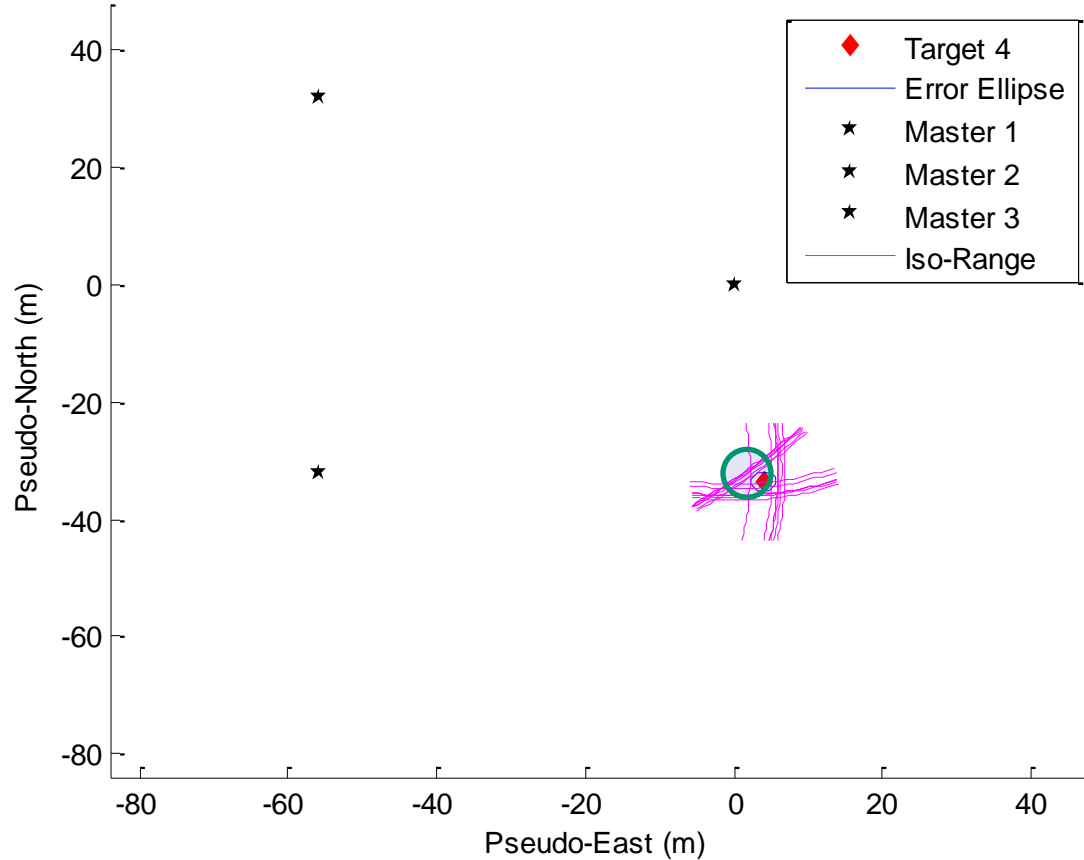

UMBC Engineering

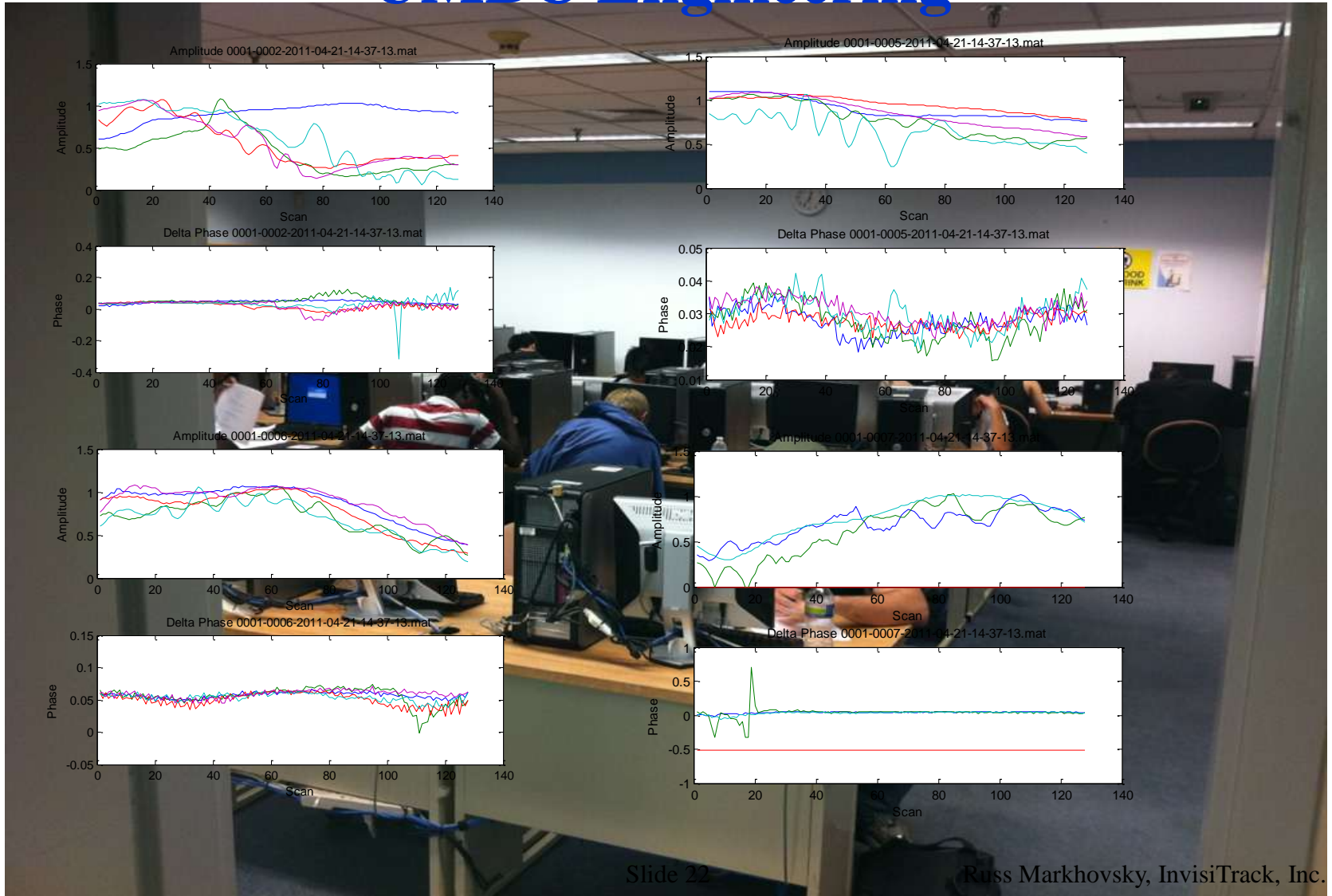

Conversion to Distance

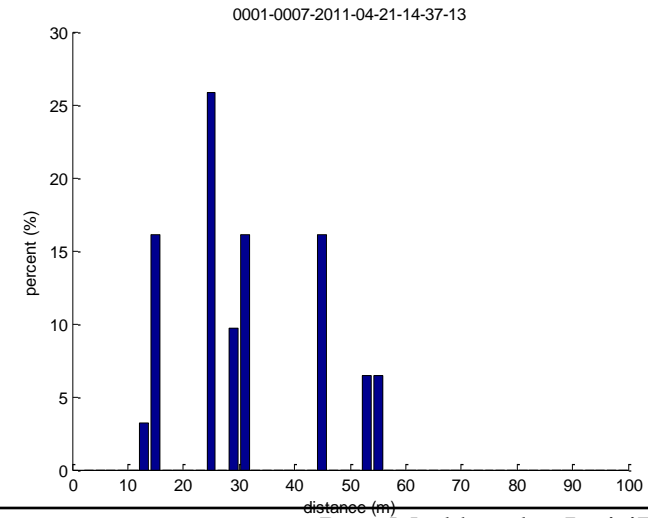
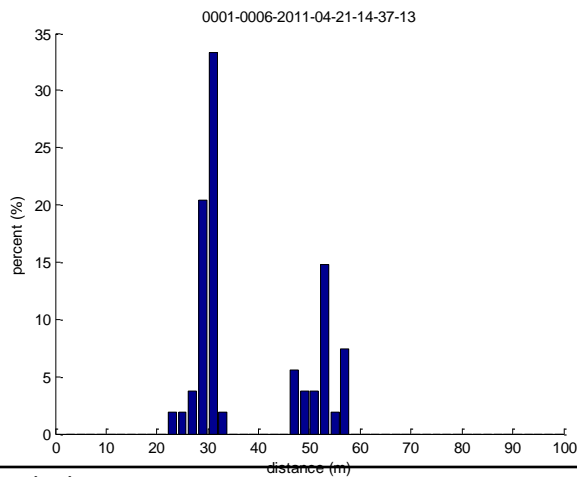
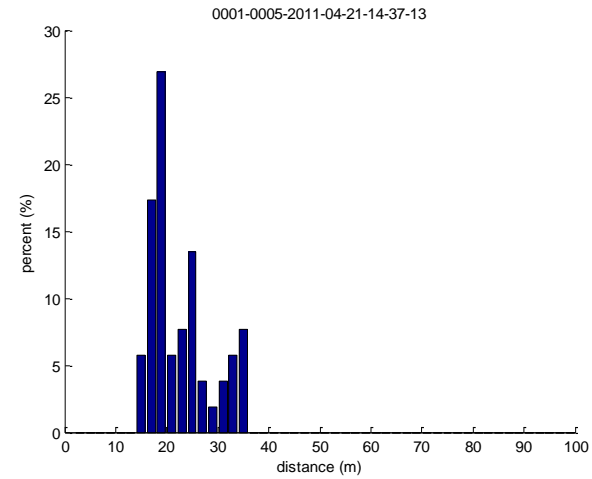
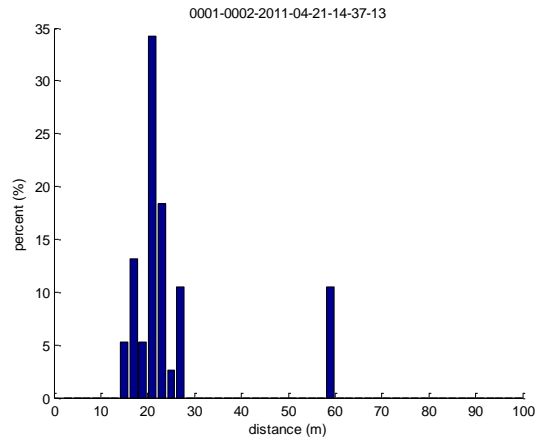

Results

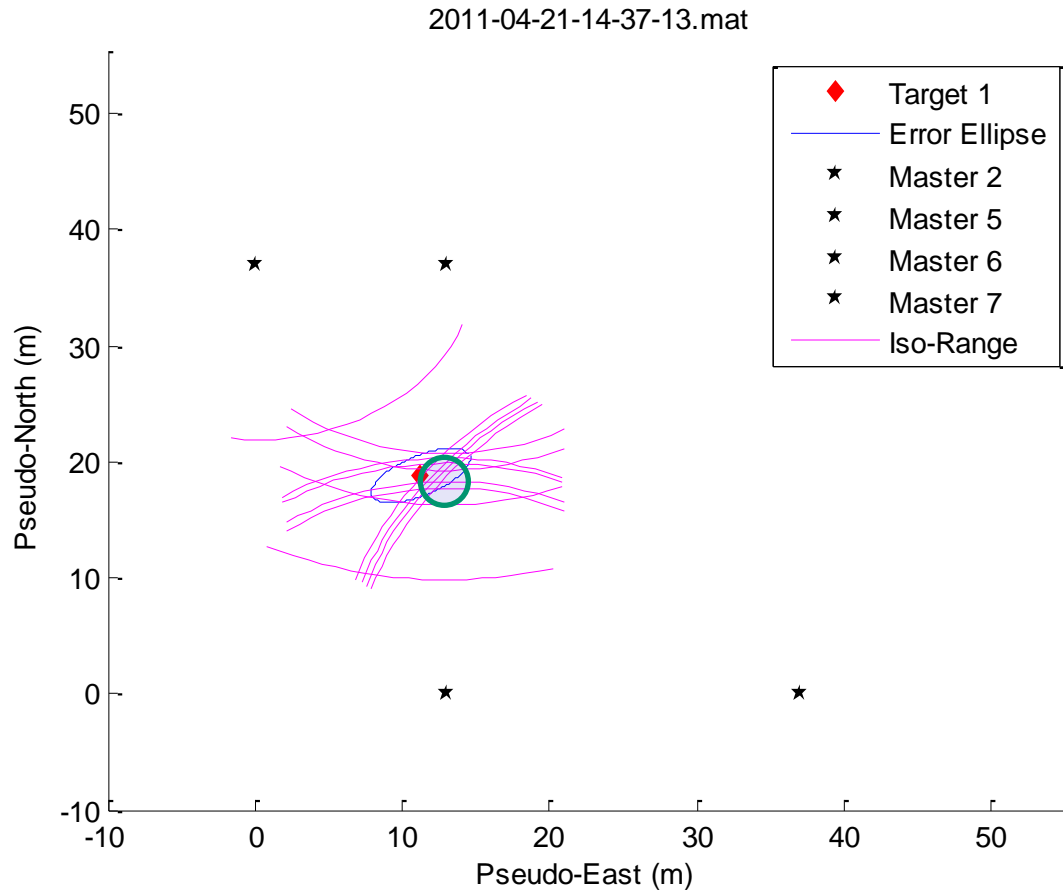

UMBC Engineering (Example 2)

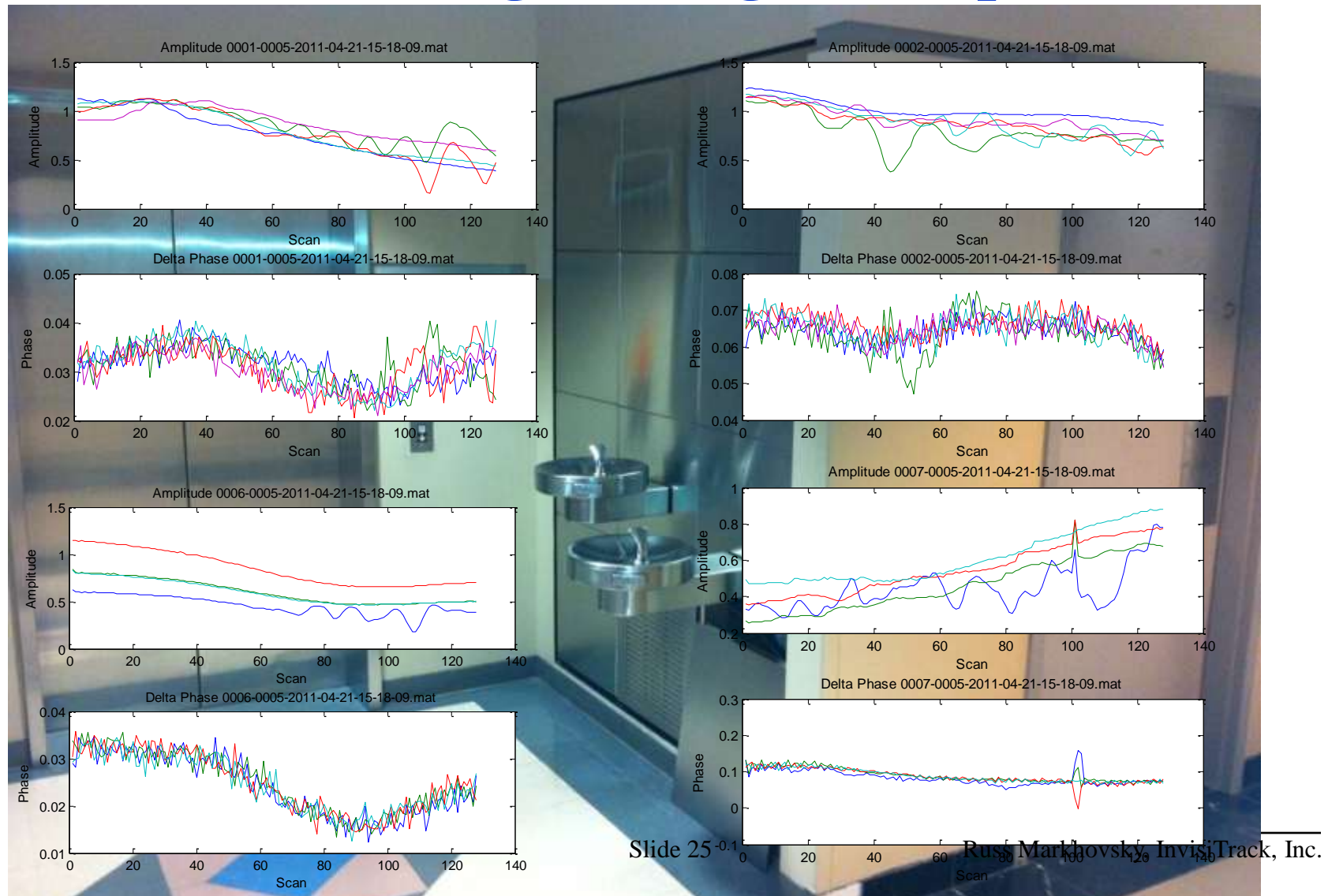

Conversion to Distance

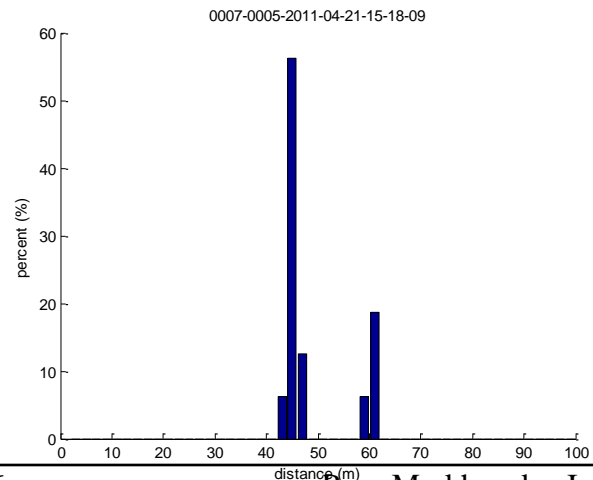
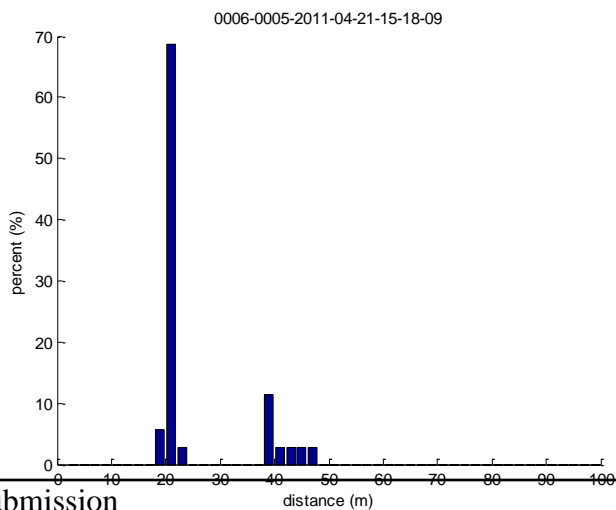
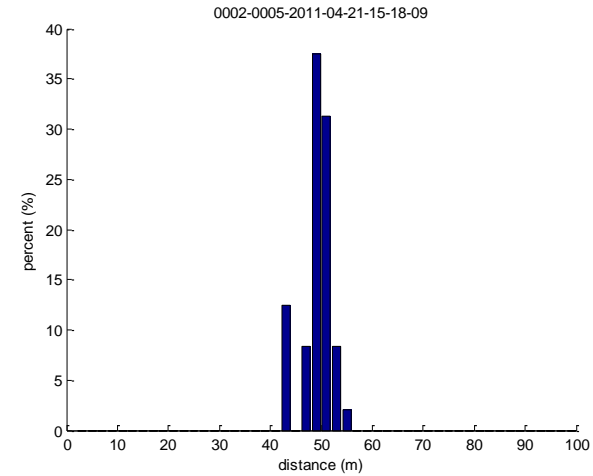
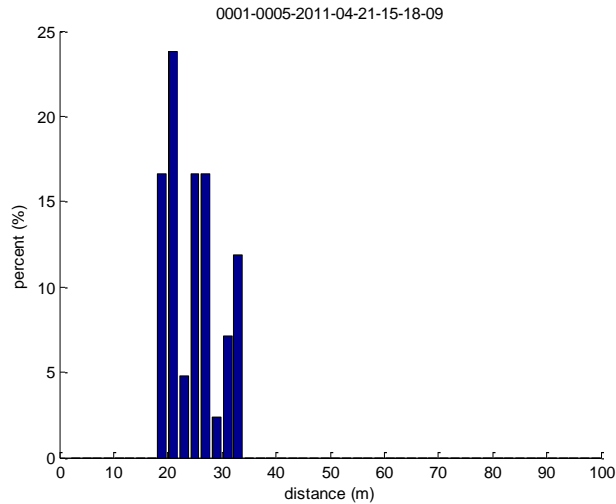

Result

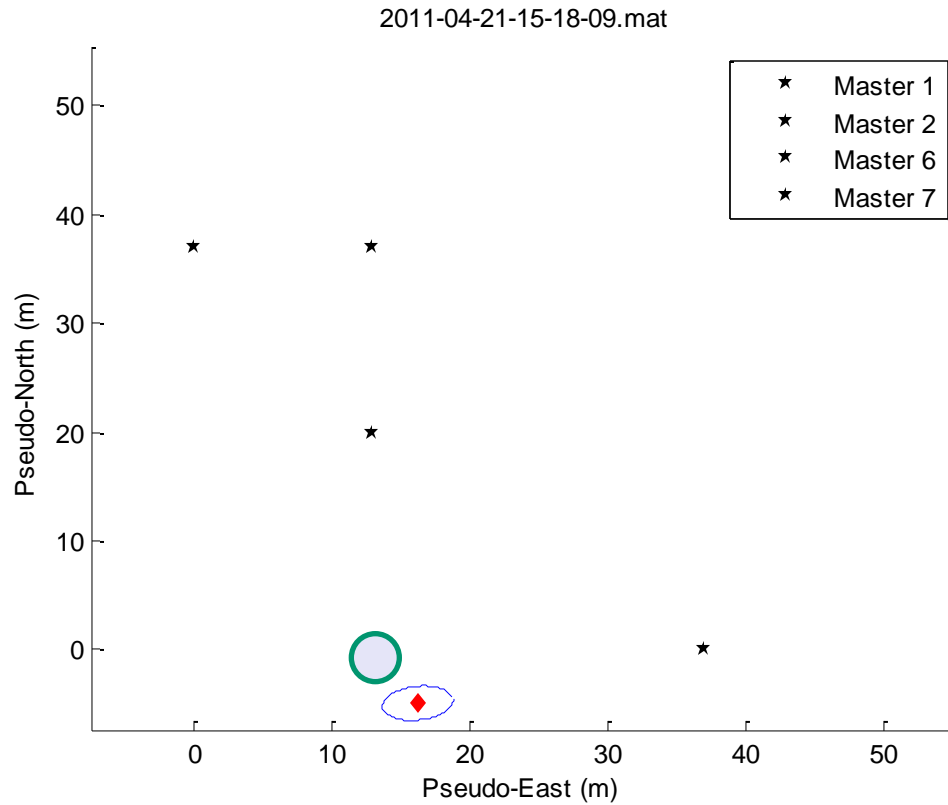

UMBC Parking Garage

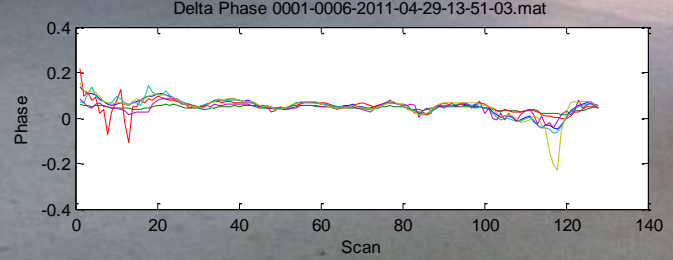
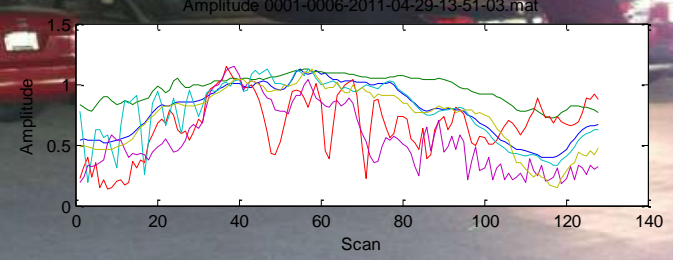
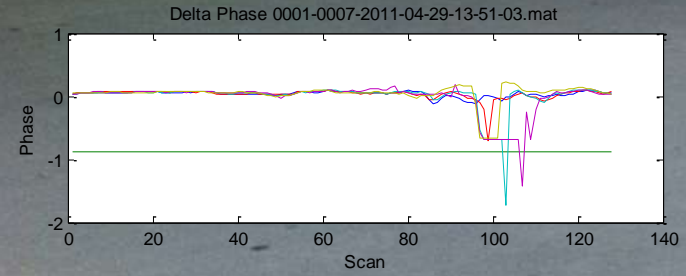
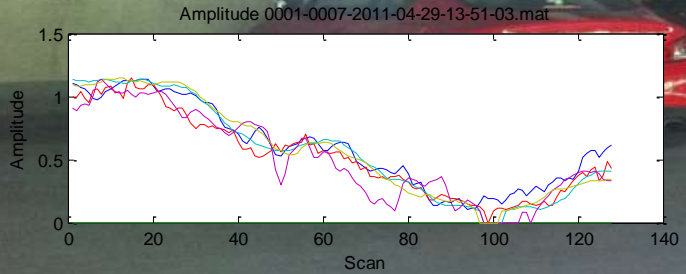
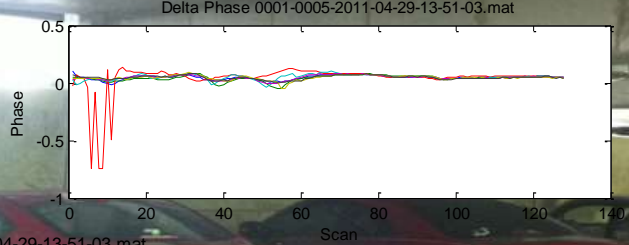
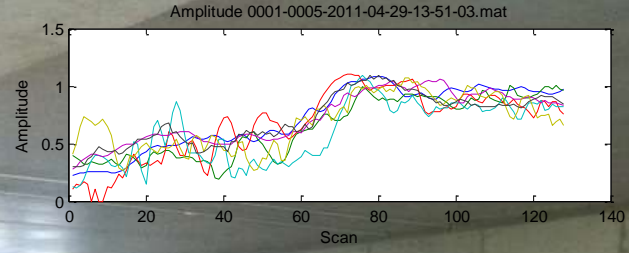
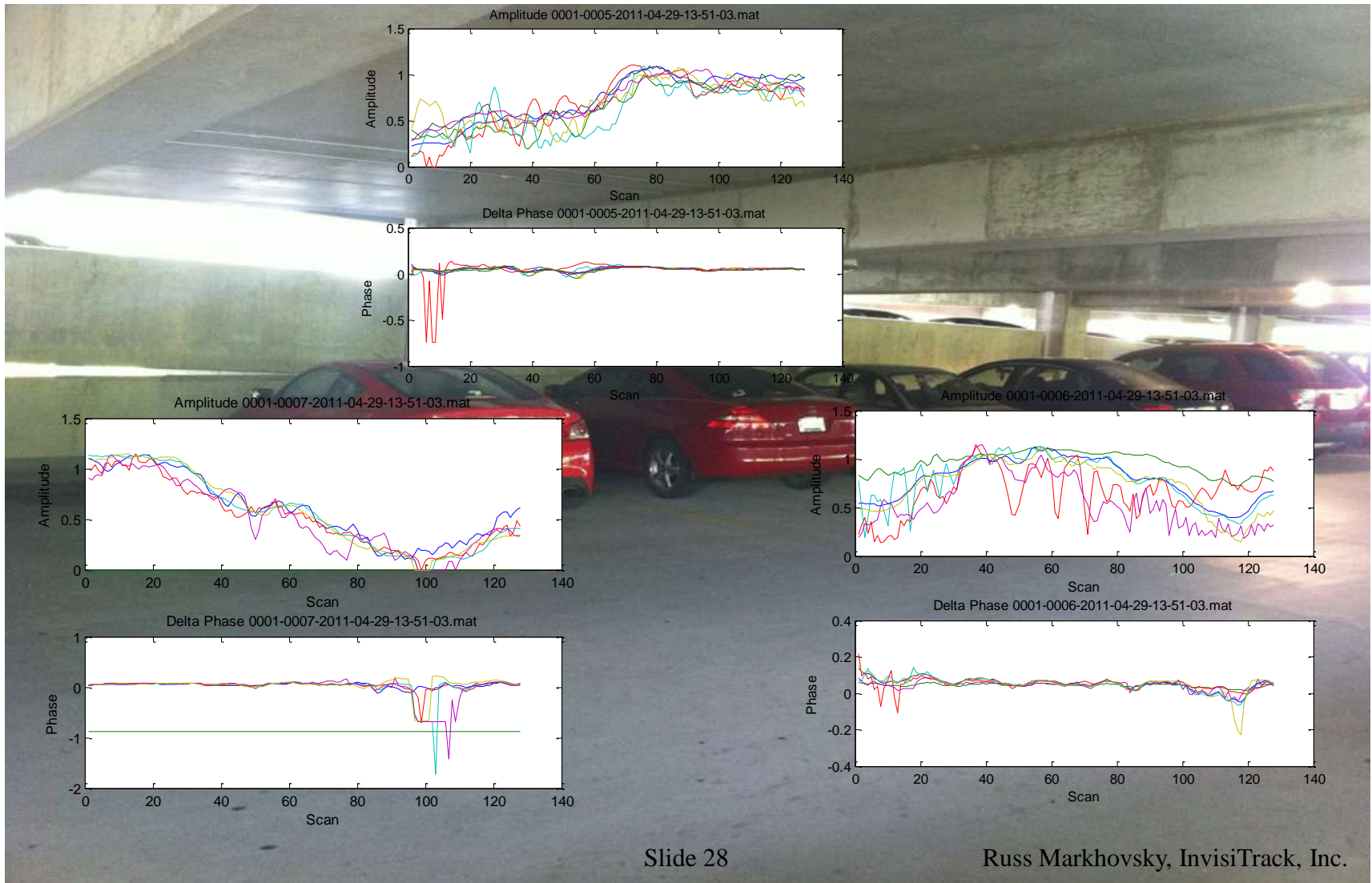

Conversion To Distance

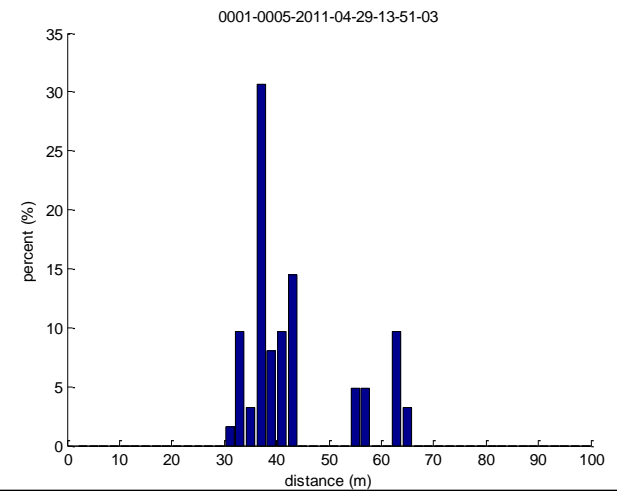
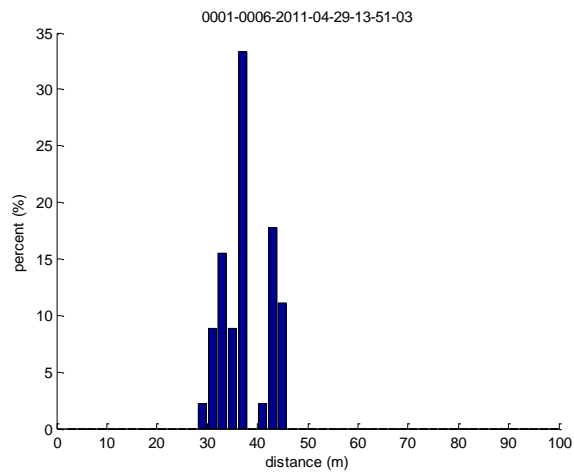
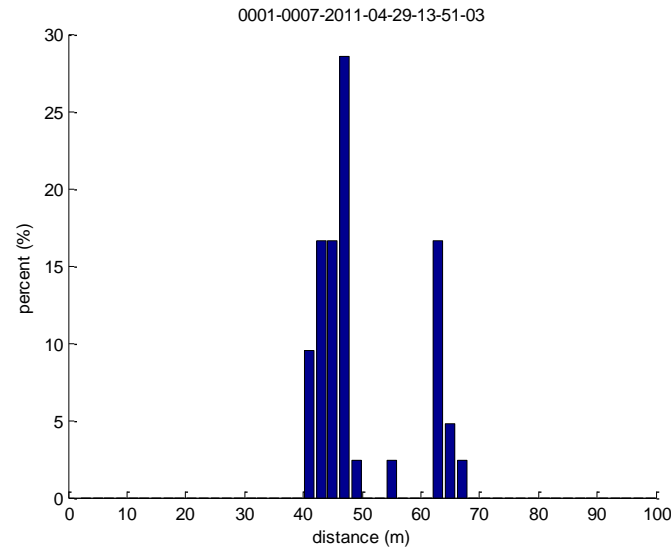

Result

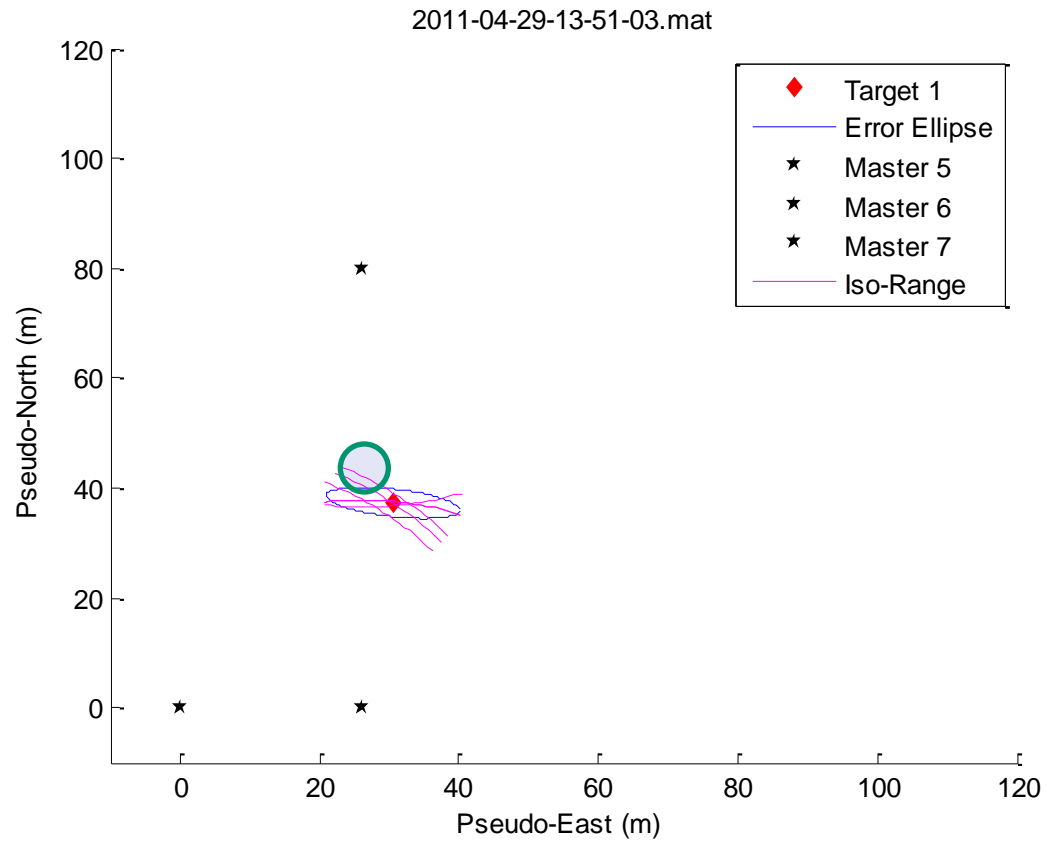

UMBC Commons

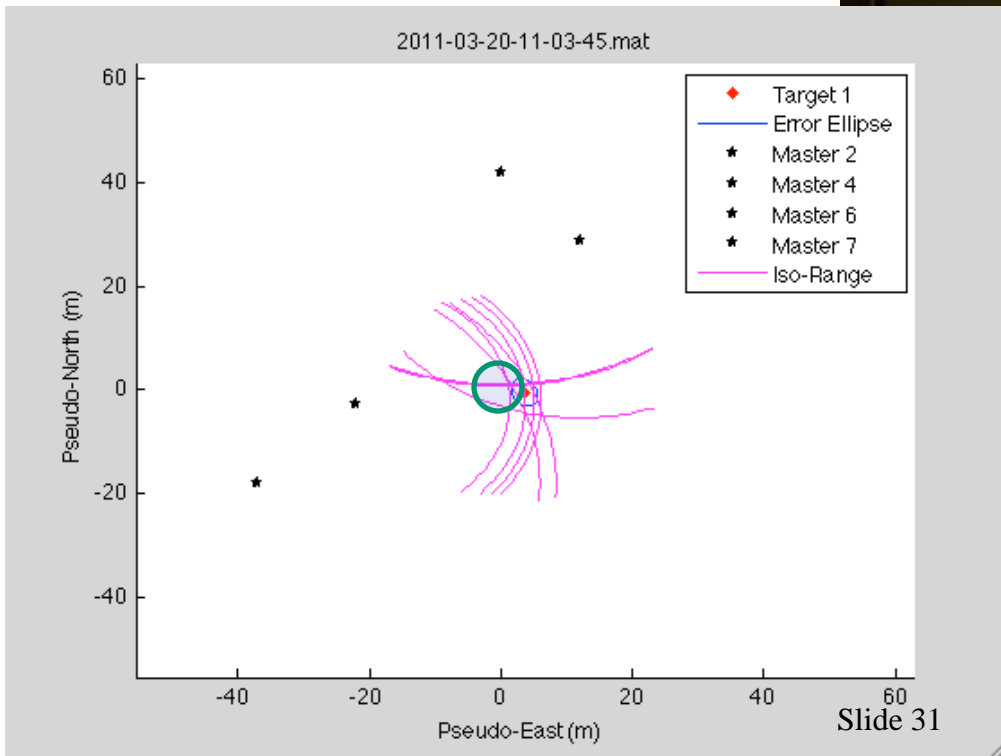
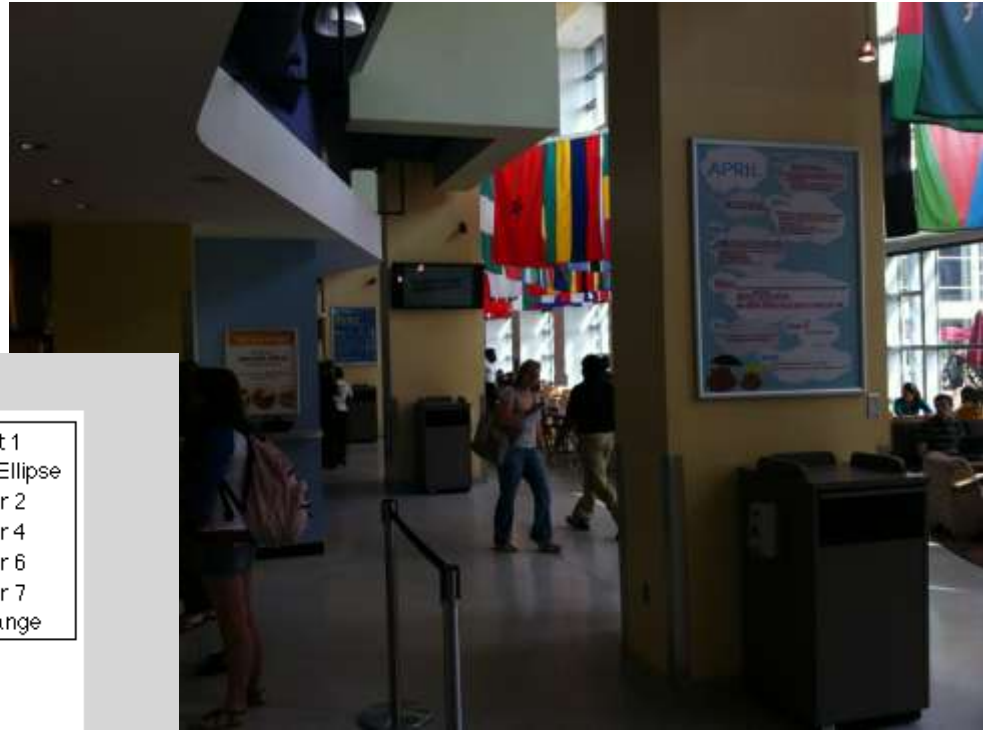

UMBC Parking Garage (Example 2)

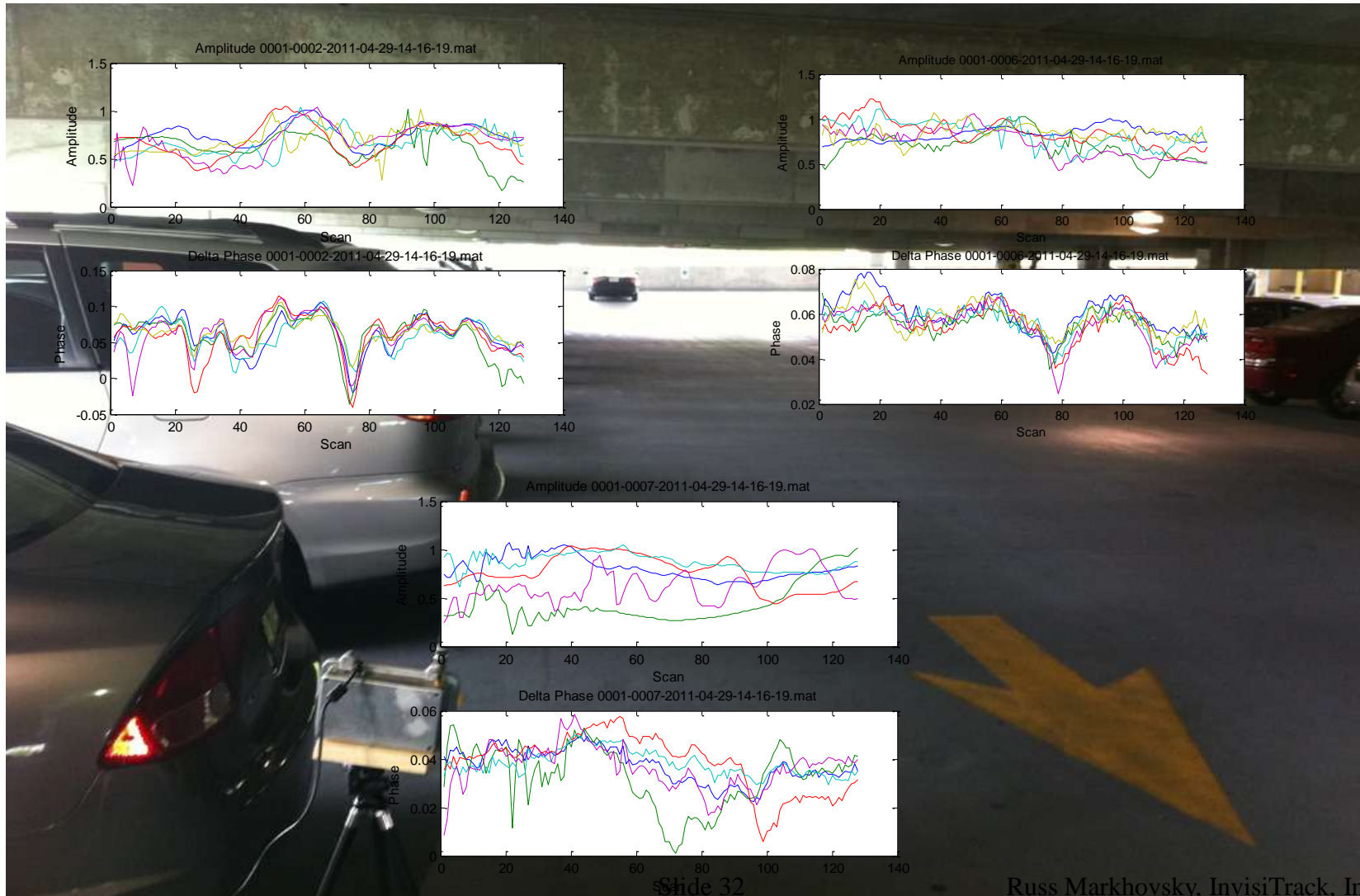

Conversion to Distance

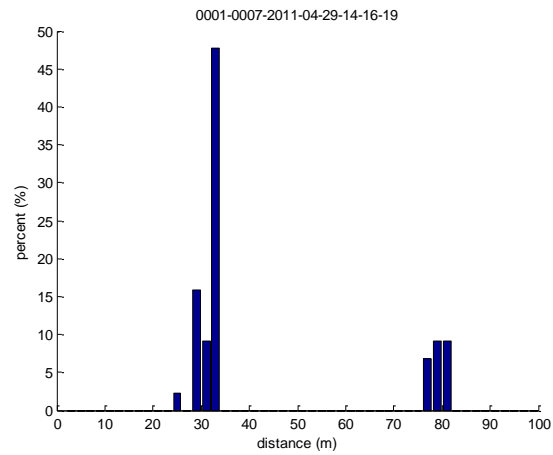
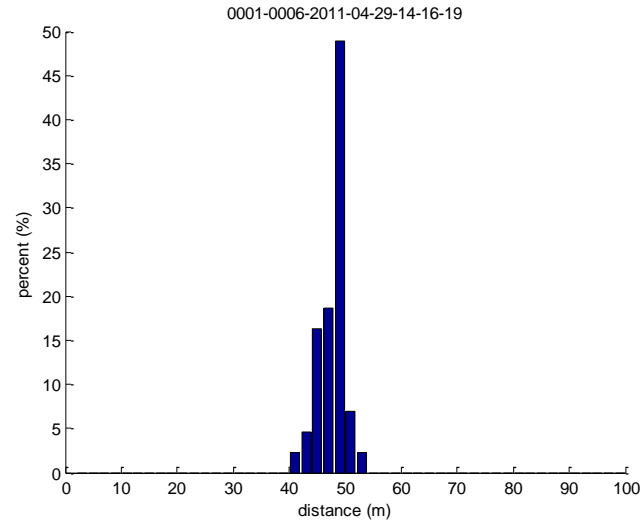
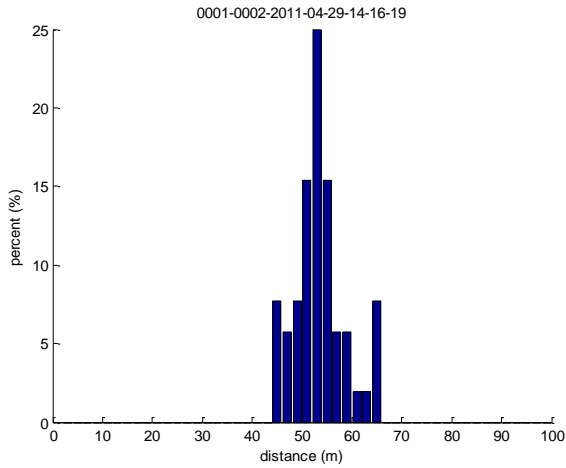

Result

2011-04-29-14-16-19.mat

