

July 2019

doc.: IEEE 802.15-19-0327-01-0dep

Project: IEEE P802.15 Working Group for Wireless Personal Area Networks (WPANs)

Submission Title: [IG DEP Transmission Power Control Using Integrated Terminal between 5G and UWB-BAN to Maximize Throughput of UWB-BAN]

Date Submitted: [15 July 2019]

Source: [Yoshinori Hirano¹, Ryuji Kohno^{1,2,3}] [1;Yokohama National University, 2;Centre for Wireless Communications(CWC), University of Oulu, 3;University of Oulu Research Institute Japan CWC-Nippon] Address [1; 79-5 Tokiwadai, Hodogaya-ku, Yokohama, Japan 240-8501

2; Linnanmaa, P.O. Box 4500, FIN-90570 Oulu, Finland FI-90014

3; Yokohama Mitsui Bldg. 15F, 1-1-2 Takashima, Nishi-ku, Yokohama, Japan 220-0011]

Voice:[1; +81-45-339-4115, 2:+358-8-553-2849], FAX: [+81-45-338-1157],

Email:[1: hirano-yoshinori-nx@ynu.jp, kohno@ynu.ac.jp, 2: Ryuji.Kohno@oulu.fi, 3: ryuji.kohno@cwc-nippon.co.jp] Re: []

Abstract: [According to trend of 5G, IoT/M2M, and increase of WBAN application, their overlapped coverage range of these networks will increase. In order to solve such a problem, a new scheme of controlling transmission power of UWB-BANs has been proposed to avoid interference to 5G terminals overlapped in coverage range. Current standard IEEE802.15.6 should be updated to apply this proposed scheme in PHY to solve a coexistence problem between primary user 5G and secondary user UWB-BAN.]

Purpose: [information]

Notice: This document has been prepared to assist the IEEE P802.15. It is offered as a basis for discussion and is not binding on the contributing individual(s) or organization(s). The material in this document is subject to change in form and content after further study. The contributor(s) reserve(s) the right to add, amend or withdraw material contained herein.

Release: The contributor acknowledges and accepts that this contribution becomes the property of IEEE and may be made publicly available by P802.15.

Transmission Power Control Using Integrated Terminal between 5G and UWB-BAN to Maximize Throughput of UWB-BAN

Fumika Nakamura*, Ryuji Kohno* †

* Graduate School of Engineering Yokohama National University

† University of Oulu Research Institute Japan – CWC-Nippon, Co. Ltd.

Agenda

1. Background
2. Aim of This Study
3. System Model
4. Proposed Scheme of Transmission Power Control Using Integrated Terminal
 - 4.1 Definition of Integrated Terminal
 - 4.2 the power control flow
 - 4.2.1 desired 5G's SINR
 - 4.2.2 how to calculate the tolerable ravel and the range of control
- 5 Performance Evaluation
 - 5.1 system model
 - 5.2 analysis
- 6 Conclusion and Future Work

1. Background

□ Demand for Wireless BAN

- In 2012, a new standard IEEE802.15.6™ of wireless medical body area network(WBAN) was established.
- Since 2020, 5G will start service nationwide in Japan and ad-hoc network will be expected to be used for IoT/M2M nodes widely coexisting with other narrow and wideband radio ad-hoc networks for Industry 4.0 and Smart Society5.0..

□ Demand for UWB

- Although Ultra Wide Band (UWB) radio regulation in Japan were limited indoor different from in other regions in a world.
- UWB radio regulation in Japan has been updated November 2018 to make its market in Japan opened to a world.
- Particularity implanted wireless BAN devices such as wireless capsule endoscope needs high dependability.

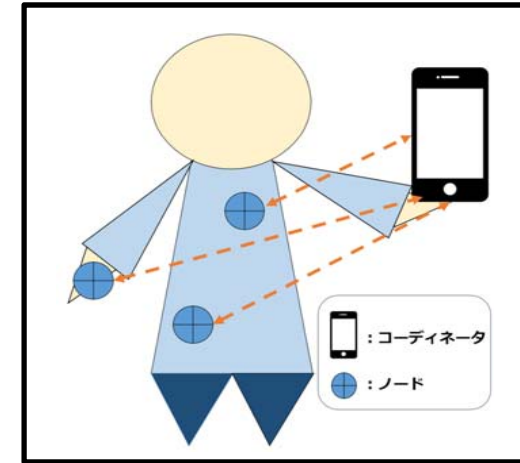

Fig.1 Feature of WBAN



Fig.2 Implanted Wireless Capsule Endoscope

Promotion of **UWB-BAN** is motivation of this study

Ref.OLYMPUS HP

2. Update of UWB Radio Regulation in Japan

- Japanese radio regulation authority MIC (Ministry of Internal Affairs and Communications) has investigated technical requirement for ultra wide band (UWB) radio use according to UWB research, development, and business after it established regulatory requirement for communication uses for 3.4-4.8GHz, 7.25-10.25GHz in 2006, and collision avoidance radar uses for 22-29GHz in 2013. While UWB communication and sensing systems have been restricted indoor in Japan, the rest of world have been developing them to a lot of outdoor uses.
- Lately in this IoT era, wide variety of UWB radio uses have been expected in Japan as well as in a world and demand for UWB radio outdoor use has been increasing while keeping transparency with other nations.

Major Change: Reference; 15-18-0546-03-0dep

- (1) Bandwidth, Occupied, and Impermissible Emission Available Outdoor; Channel 9 of IEEE802.15.4a™ with central frequency 7987.2GHz and bandwidth 499.2MHz out of high band 7.25-10.25GHz has been considered to be available outdoor.
- (2) EIRP(Equivalent Isotropically Radiated Power); Japanese regulatory requirement for UWB radio has been regulated by emission power, antenna gain as well as EIRP. For the sake of international compatibility, Japanese regulation for UWB radio uses could be regulated by EIRP.

2.1 Radio Uses in the Frequency Band 6.57-10.25GHz in Japan

- **Red lines** indicate channels defined by **IEEE802.15.4a**.
- Available band is 7.587-8.4GHz. **Blue dotted line** systems should be protected for coexistence such as fixed micro wave communication, satellite, radio astronomy and VLBI etc.

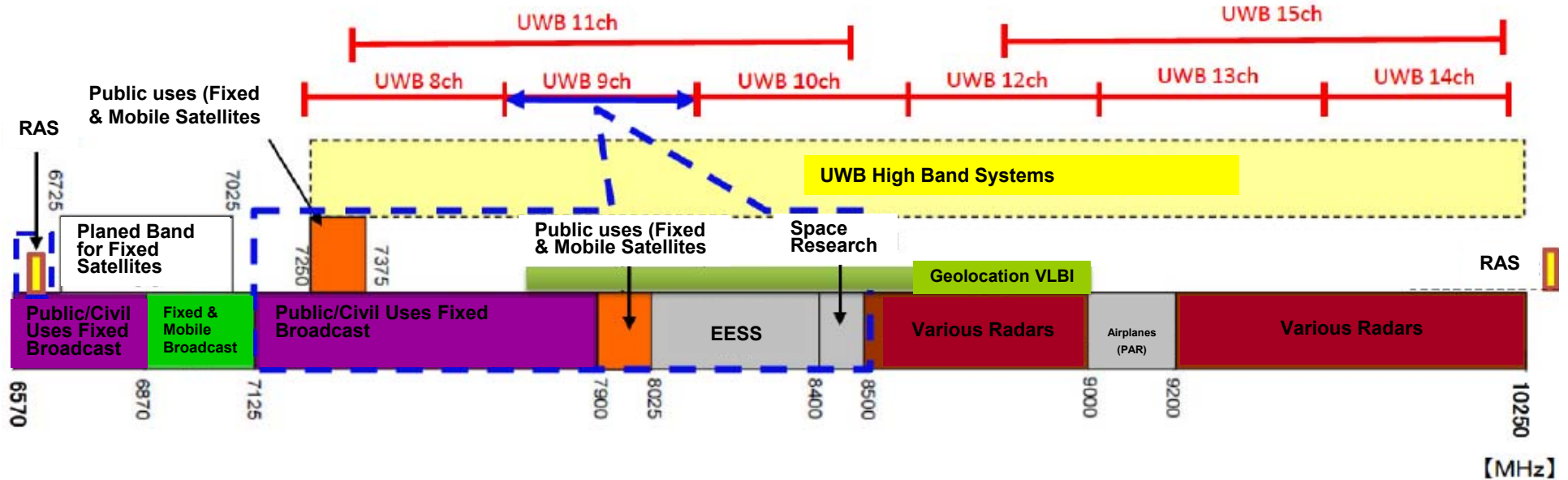

2.2 Update of Emission Power Regulation in case of Low Gain Antenna

- Recently demand of small wireless terminals including UWB terminals drastically. A small terminal cannot perform desired covering range because antenna gain of small terminals is used not to be sufficient.
- Corresponding to the demand, it is permitted that under the range of the regulated Equivalent Isotropically Radiated Power (EIRP), antenna gain can be increased according to attenuation amount of emission power. Increase of emission power can be replaced with attenuation of transmitted antenna gain.

Current Regulation

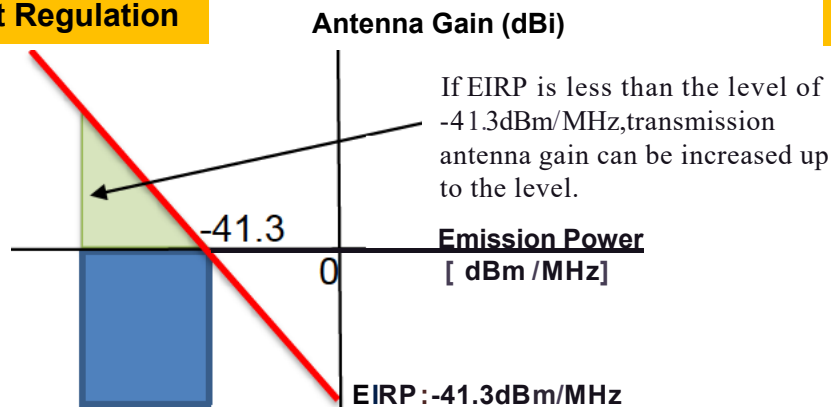

Average Power -41.3 dBm/MHz
Peak Power 0 dBm/50MHz

Transmission absolute antenna gain should not exceed 0 dBi.
If and only if EIRP is lower than the level of -41.3dBm/MHz, transmission antenna gain can be increased so that EIRP can not be exceed the level.

New Regulation

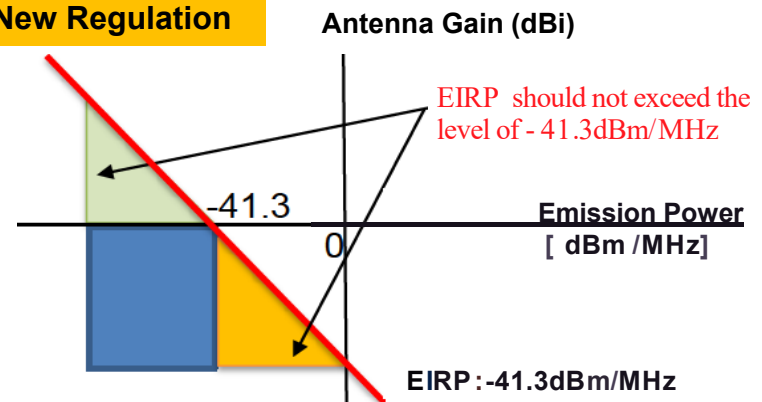

Average Power -41.3 dBm/MHz (defined by EIRP)
Peak Power 0 dBm/50MHz (defined by EIRP)

EIRP should not exceed the level of -41.3dBm/MHz.

- In current regulation, it is permitted that under the limit of the regulated EIRP, antenna gain can be increased according to attenuation amount of emission power.
- In new regulation, it is permitted that under the range of the regulated EIRP increase of emission power is allowed in case that antenna gain is small to reach the regulated EIRP

2.3 Updated UWB PSD Mask for Outdoor Uses in Japan

Power(dBm/MHz)

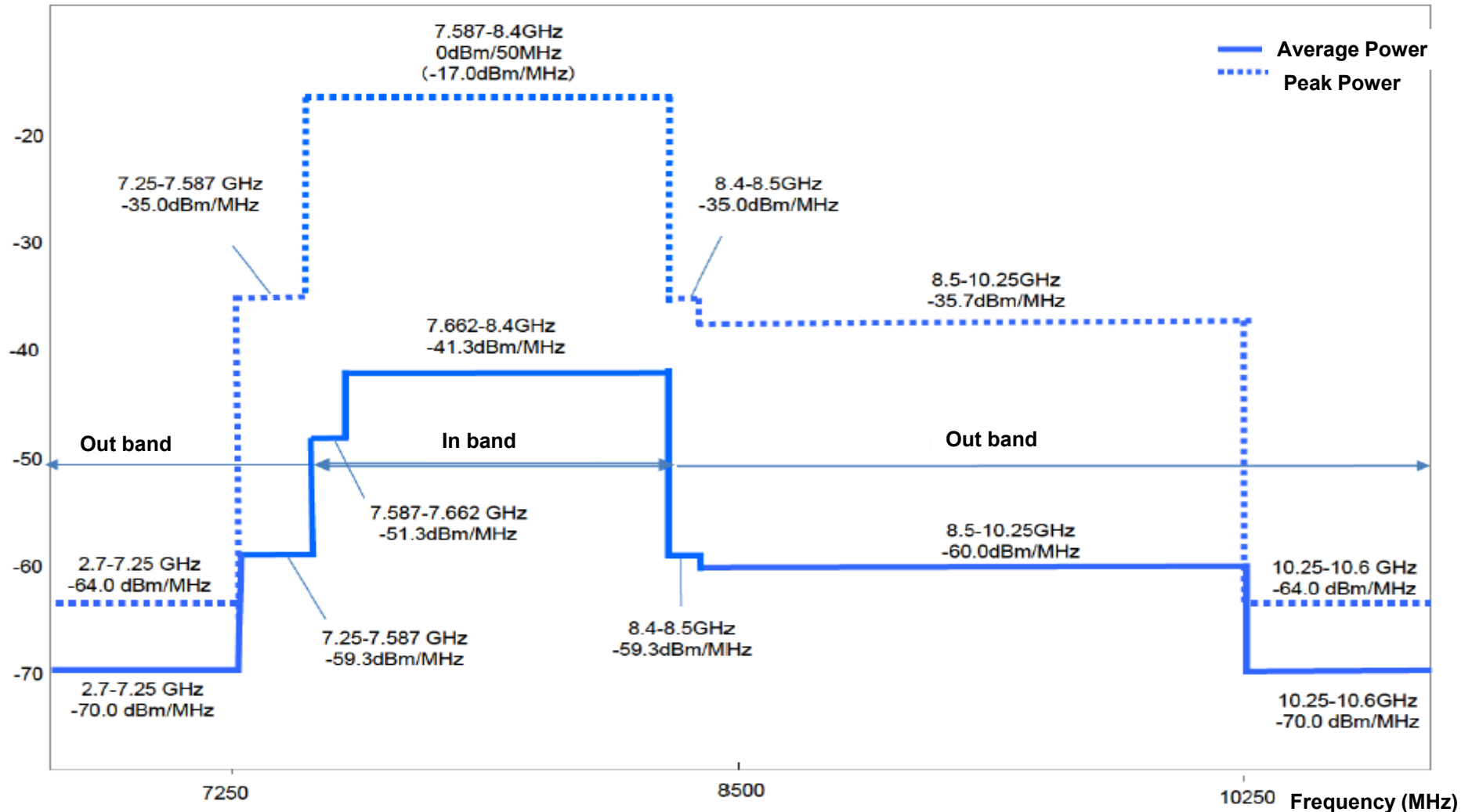

3. Methods for Interference Mitigation of UWB to License Radios

- In order to avoid interference of unlicensed radio so-called Secondary User (SU) such as WLAN, WPAN, WBAN into licensed radio so-called Primary User (PU) such as 3G, 4G, 5G cellular systems, radio regulator restricts emission radio power of SU not exceeding beyond defined spectrum mask, typically EIRP should be less than -41.3dBm/MHz in microwave band.

Co-Existing Schemes between PU and SU

- Schemes of avoiding interference of SU to PU are categorized into two classes.
LDC (Low Duty Cycle); a scheme to restrict duty cycle of transmitted radio packets to make average emission power under the permissible upper bound by the regulation.
DAA (Detection and Avoid); a scheme to detect radio signals from SU and avoid its interference to PU such as carrier sensing etc.

LDC is easier to be implemented but probabilistically exceed the permissible upper limit.

DAA needs precise detection of inference and throughput of SU may be degraded due to stop transmission to avoid the interference to PU.

4. Focused Problem of Overlaid UWB and 5G Radios

PU (Primary User) → 5G Cellular System
 SU (Secondary User) → UWB-BAN

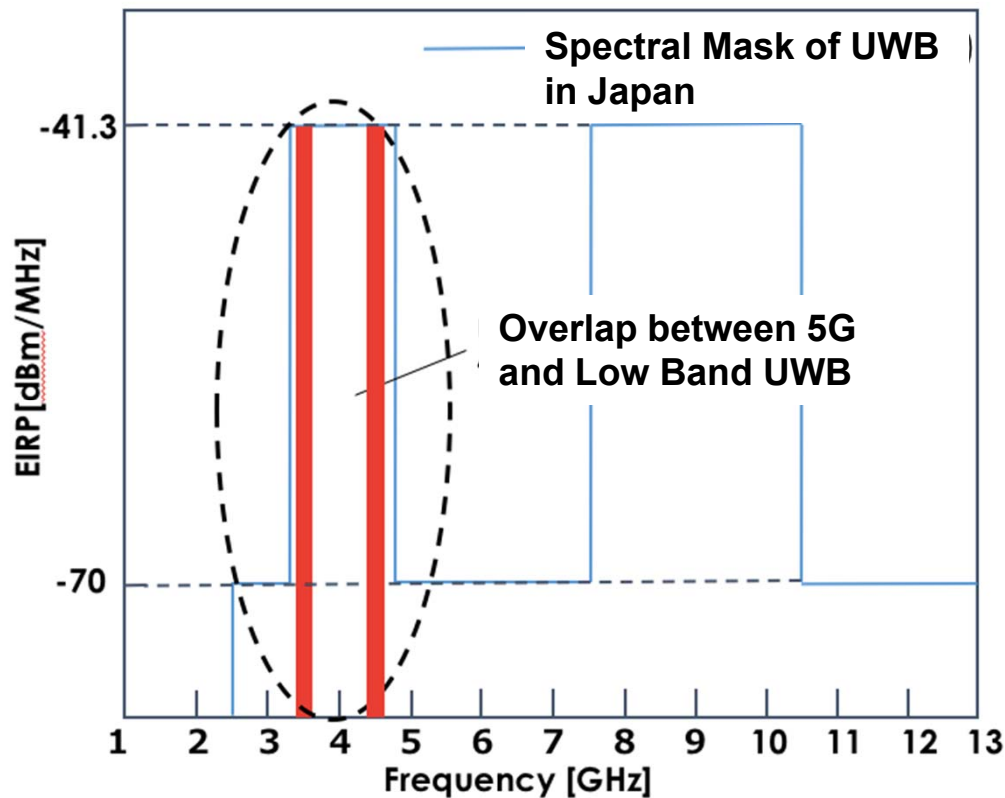

UWB

- Low Band (3.4~4.8GHz)
- High Band(7.15~10.25GHz)

By Japanese UWB regulation,
 DAA is mandatory for Low Band

5G

- Lower than 6GHz;
3.6~4.2GHz, 4.4~4.9GHz
- Higher than 6GHz
 27.5~29.5GHz

Fig.3 Spectral Mask in Low Band UWB in Microwave

5. Aim of This Study

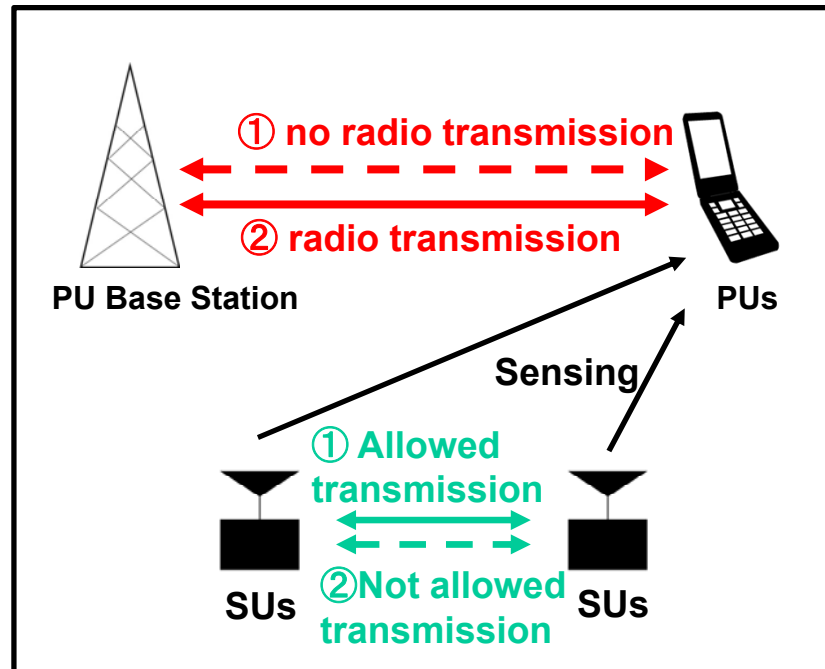

Fig.4 Conventional Sensing

- ① While no transmission by PU(5G)
SUs(UWB-BAN) can **transmit signals**
 - ② While transmitted by PU(5G)
SUs(UWB-BAN) has to **stop transmission**
- ↓
To guarantee QoS of PU, SU(UWB-BAN) stops transmission corresponding to radio regulation

Throughput of SU significantly degrades.

- ✓ To improve throughput of SU; UWB-BAN, UWN-BAN does not stop transmission and cognitively **control transmission power** so as to restrict interference never exceed the permissible level of interference of UWB to 5G.
- ✓ To accomplish transmission power control, a concept of "**integrated Terminal**" which has both PU:5G and SU:UWB-BAN transceivers

5.1 Integrated Terminal of PU(5G) and SU(UWB-BAN)

- Integrated Terminal which has functionalities of both PUs(5G) and SUs(UWB) transceivers is not so difficult be assumed such as a current smart phone has both 4G and Wi-Fi, BT in general.
- Probably soon integrated terminal of 5G and UWB-BAN will be produced.
- Integrated Terminal is a gateway for 5G and UWB-BAN so that can coordinate precise sensing interference from all UWB-BAN terminals to all 5G terminals while controlling transmission power of UWB-BAN terminals to avoid interference to 5G so as to maximize throughput of UWB-BAN.

Integrated Terminal works as a coordinator between two networks of 5G and UWB-BAN

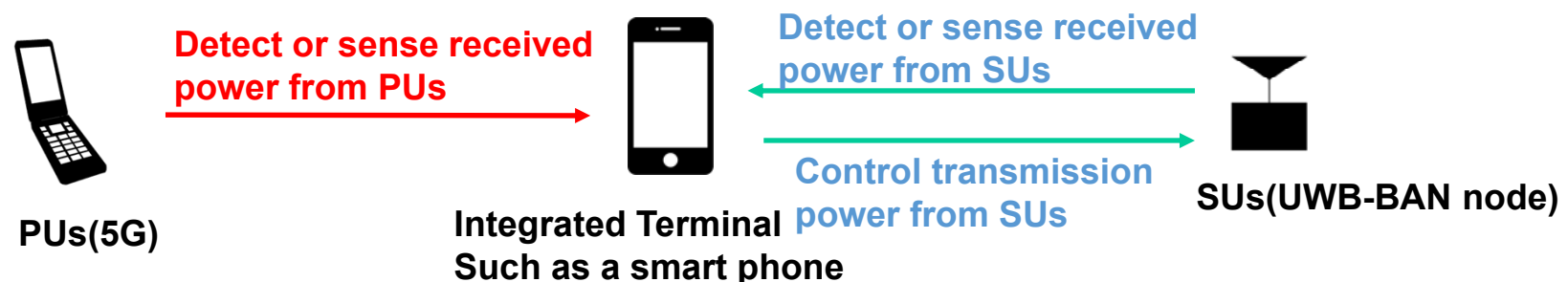

6. Proposed Transmission Power Control Using Cooperative Sensing by Integrated Terminal

Proposal method is divided into two part such as

6.1 Sensing part

6.2 Transmission power control part

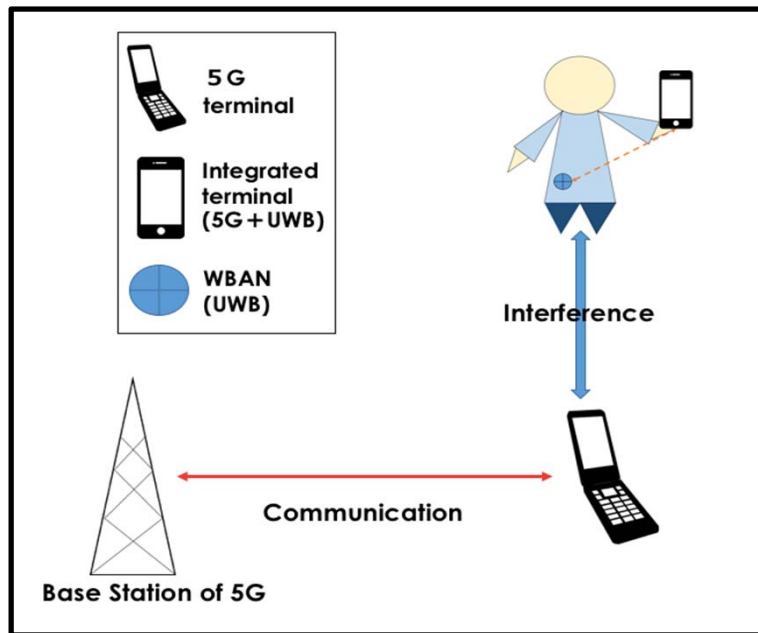

Fig 5 assumed environment

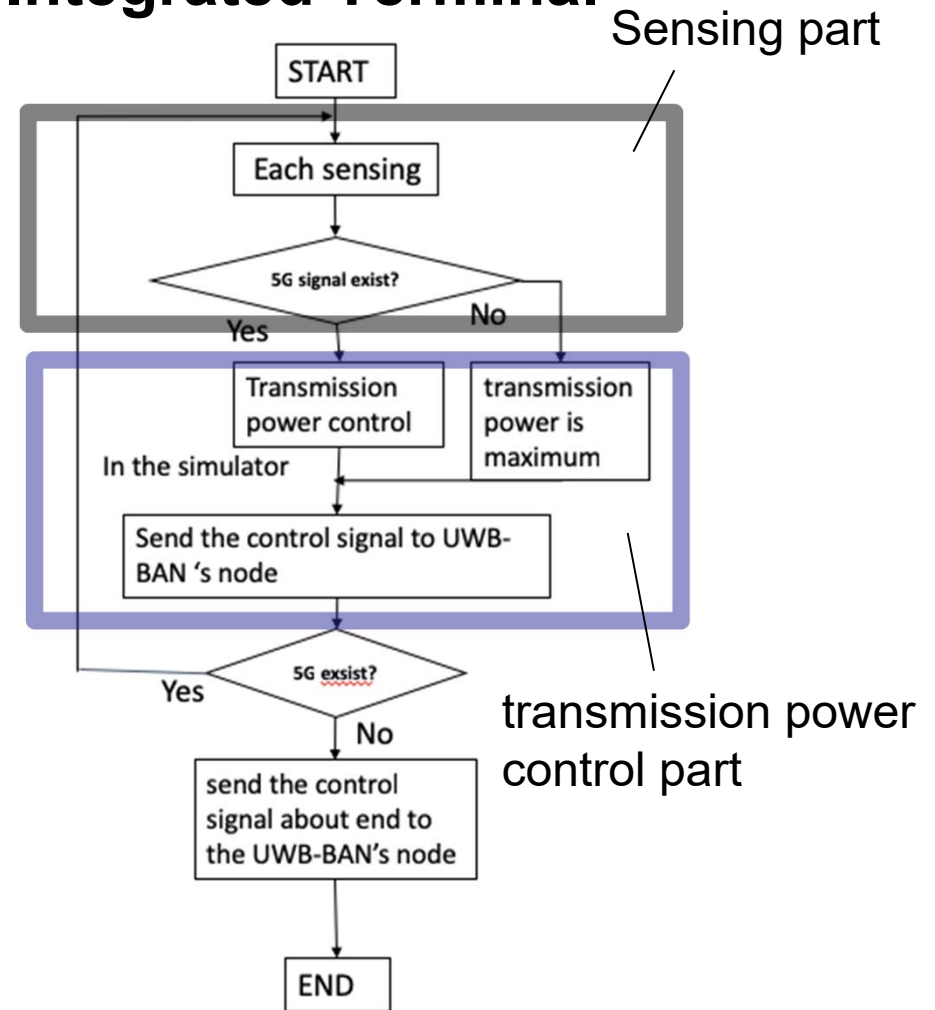

Fig 6 flow chart of integrated terminal

6.1 Cooperative Sensing for 5G Signals

□ Independent Sensing

- ✓ Detection Errors due to Path Loss
- ✓ Detection Errors due to Shadowing



Accuracy of detecting PU(5G) signals can be Improved by cooperation of SU(UWB) nodes

□ Cooperative Sensing

Process Follow

- (1) Try to detect PU(5G) signals independently with all SU(UWB) nodes
- (2) Fusion Center collects all the detecting data
- (3) Fusion Center judges if PU signals exist or not.
- (4) Fusion Center judgement will be broadcast to all modes

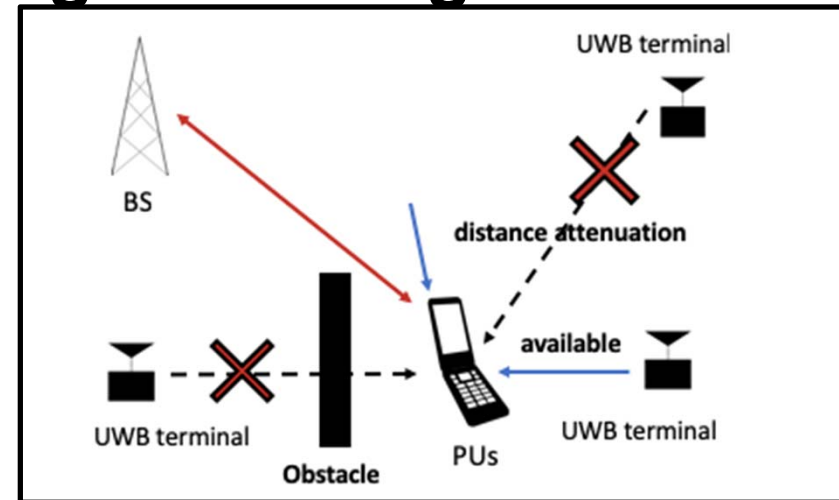

Fig.7 Problem in Independent Sensing

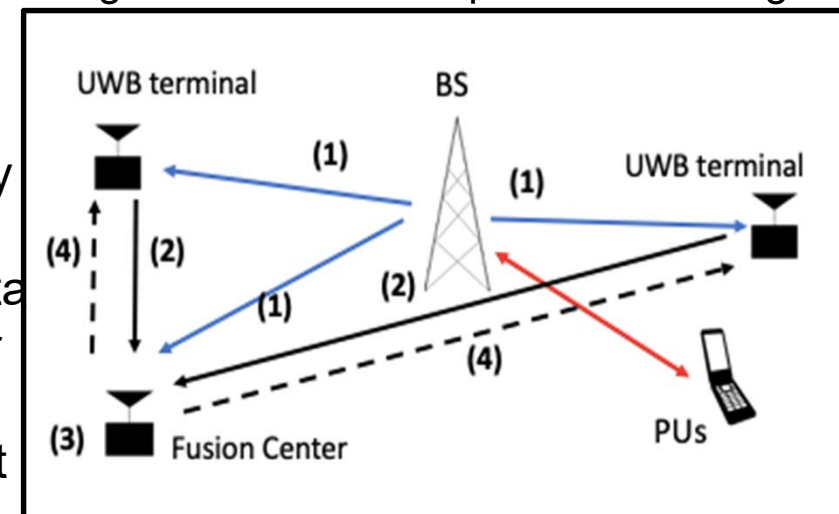

Fig.8 Process of Cooperative Sensing

6.1.1 Detection and False Alarm Probabilities in Sensing

- In case of OR-Rule Cooperative Sensing

→ If any single node out of all PU nodes detects PU detect signal, It will be determined to detect PU signal.

False Alarm Probability(P_{fa}) and Miss Detection Probability(P_{df}) are described below

$$P_{fa} = Q\left(\frac{\gamma - M\sigma_w^2}{\sqrt{2M\sigma_w^4}}\right) \quad P_{df} = Q\left(\frac{\gamma - M(\sigma_w^2 + \sigma_x^2)}{\sqrt{2M((\sigma_w^2 + \sigma_x^2))^2}}\right)$$

γ : Detection Threshold

Threshold can be derived if desired P_d or P_{fa} is given

N: number of sensing nodes

$$P_{fa}^{OR} = 1 - (1 - P_{fa})^N \quad P_{df}^{OR} = (P_{df})^N$$

Distance with 5G is known

- By radio regulation, detection probability is defined probability of correctly detect signal over 95%
- False Alarm Probability is minimized by guarantee over 95% of Detection Probability

Miss Detection Probability is used to be trade-off with False Alarm Probability

6.1.2 Single and Cooperative Sensing Results

- About the single sensing (System Flow)
- The problem of the single sensing
- About the cooperative sensing (System Flow)
- Analysis of Cooperative sensing

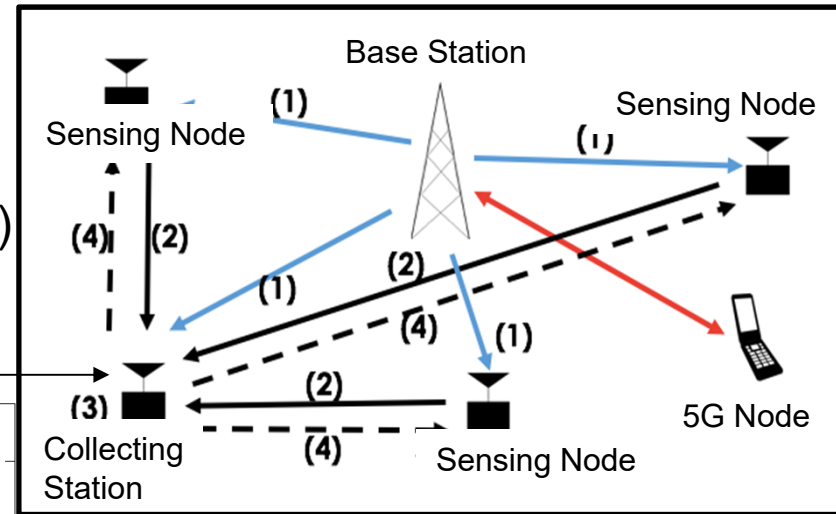

Fig 9 cooperative sensing

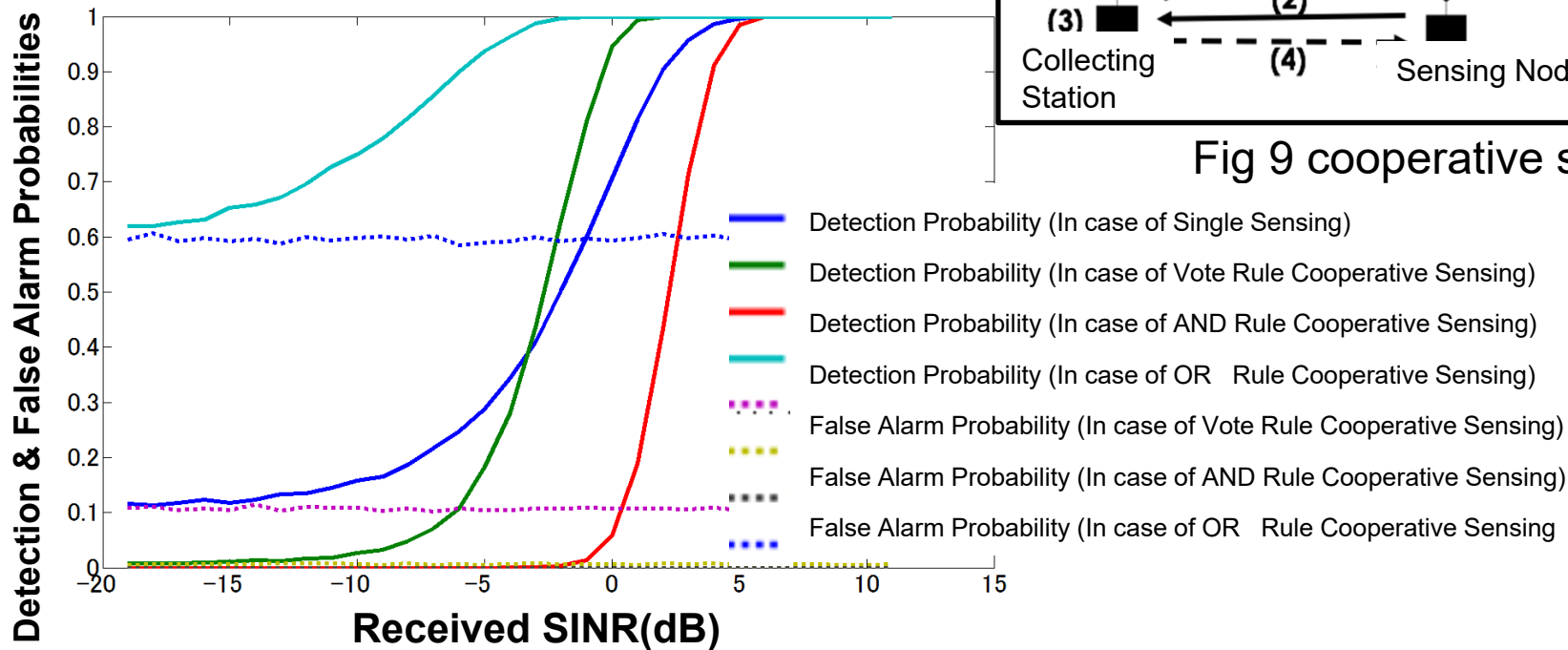
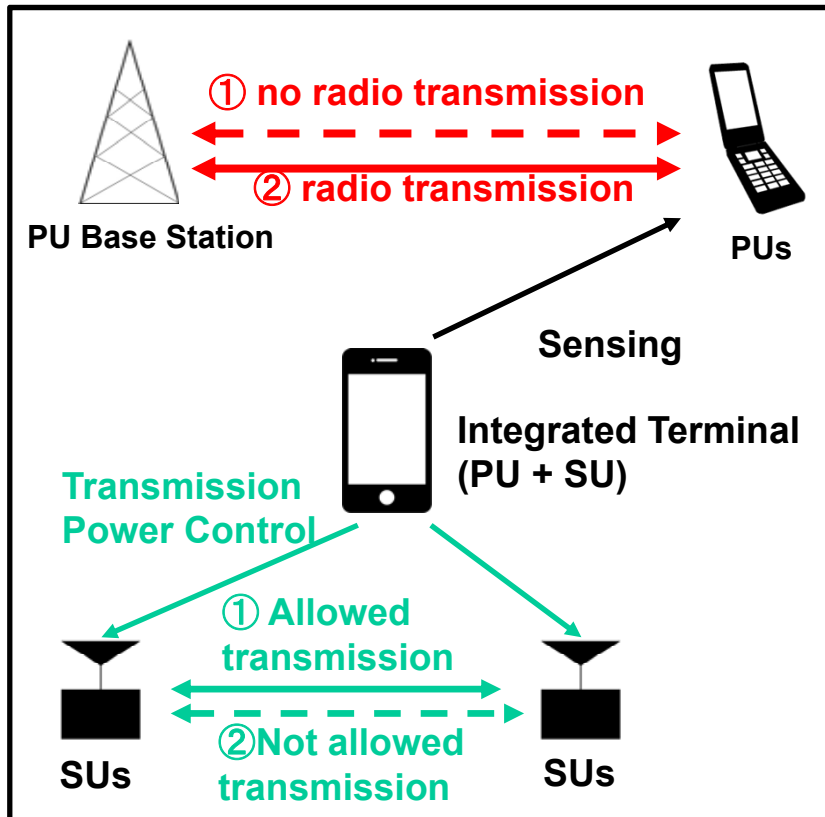

Fig. 10 Received SINR vs False Alarm or detection

6.1.3 Proposed Scheme of Cognitive Cooperative Sensing 5G Signals and UWB-BAN Interference with Integrated Terminal



① While no transmission by PUs(5G)
 SUs(UWB-BAN) can **transmit signals**

② While transmitted by PUs(5G)

SUs(UWB-BAN) can **transmit signals while no need to stop transmission**

↓
 To guarantee QoS of PU, SU(UWB-BAN) control transmission power of UWB-BAN corresponding to radio regulation

Throughput of SU can be improved

Fig 11 Cognitive Sensing Interfering UWB-BAN Power by Integrated Terminal

6.1.4 Miss Detection and False Alarm Probabilities of the Proposed Scheme of Cognitive Cooperative

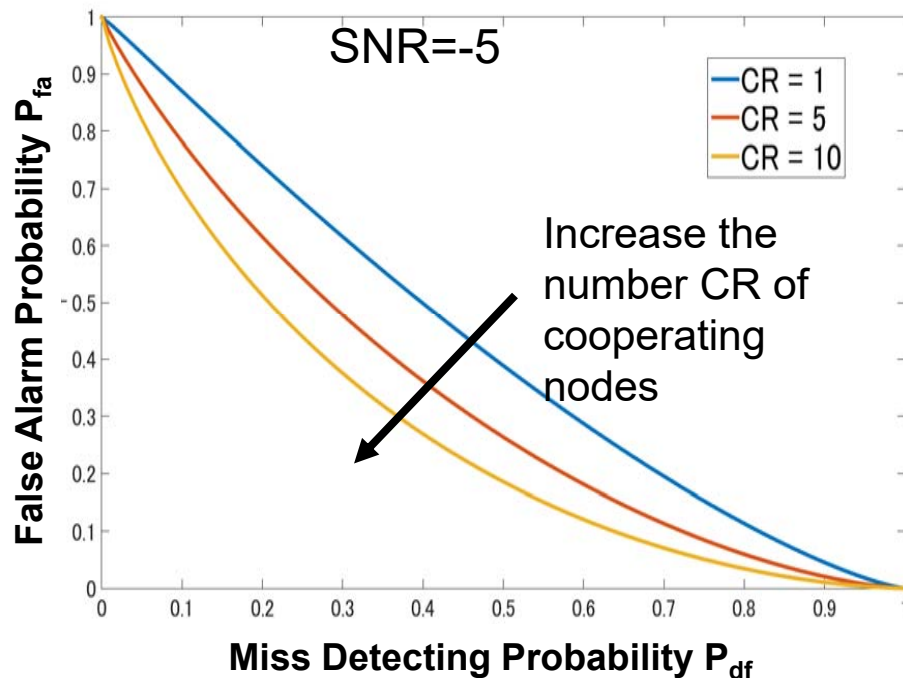

Fig.12 Miss Detection Probability P_{df} vs False Alarm Probability P_{fa} according to No. of Cooperative Sensing Nodes (CR)

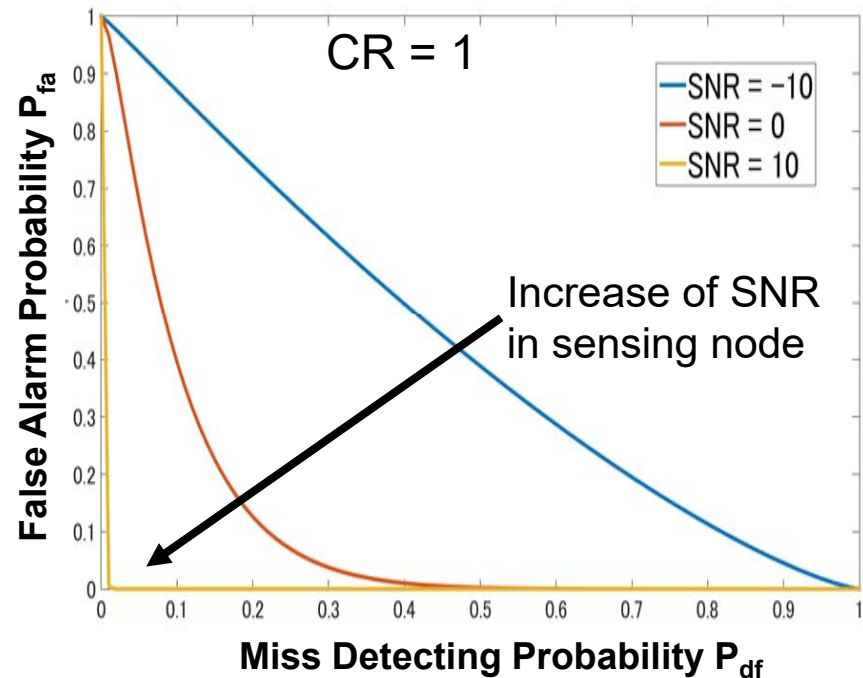

Fig.13 Miss Detection Probability P_{df} vs False Alarm Probability P_{fa} according to SNR in Sensing Node

Sensing Performance can be improved according to increase of sensing nodes and/or SNR in sensing node

6.1.5 Detection and False Alarm Probabilities of the Proposed Cooperative Sensing according to Distance

- Decision threshold is determined for requested false alarm probability P_{fa}

Table Specification

Sampling number	16
Distance from BS	1 ~ 100[m]
Number of CR	5
Power of noise	-95[dBm]
SNR of PUs	10[dB]
Distance BS to PUs	25[m]
Center frequency	3.5[GHz]
Desired Pfa	0.1

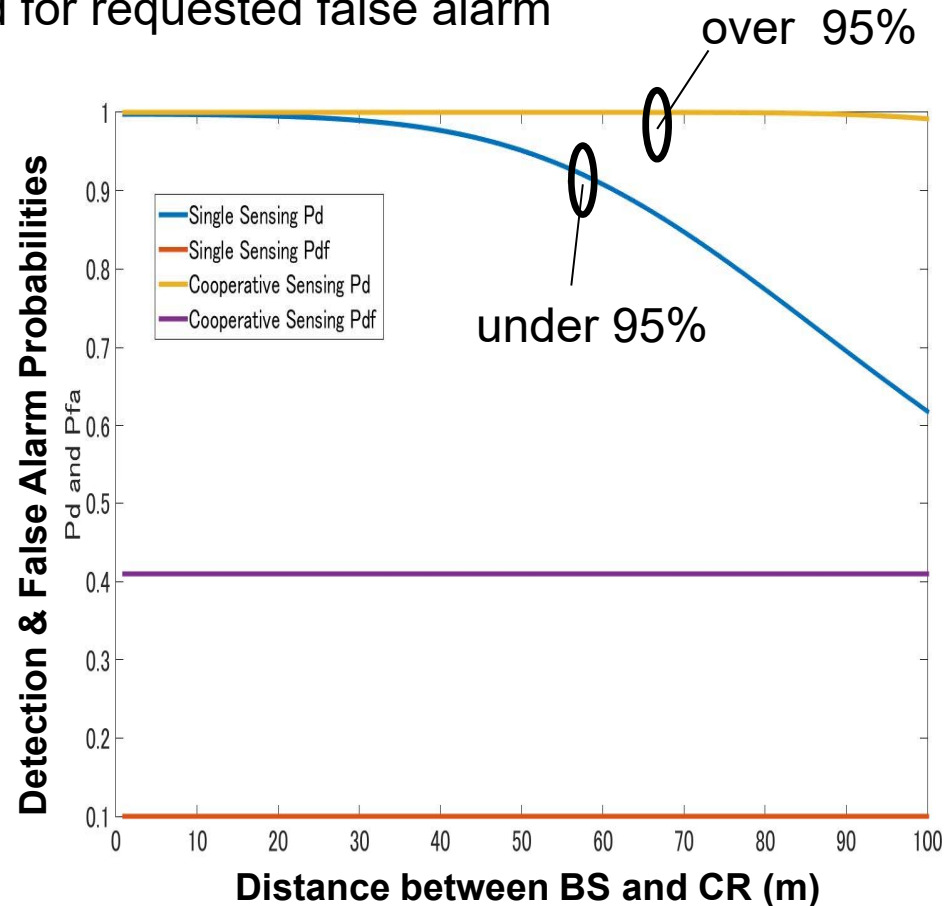
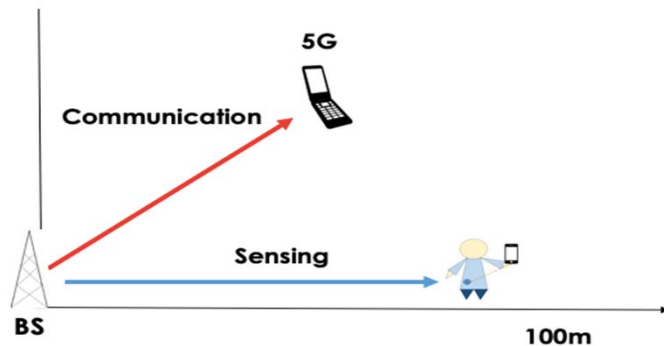

Fig.14 the distance between BS of PUs and sensing nodes vs detect probability P_d and false alarm probability P_{fa}

6.2 Proposed Transmission Power Control of UWB-BAN Using Cooperative Sensing with Integrated Terminal

Process

1. Acquiring location information of all terminal nodes, simulator is set up in integrated terminal



2. Simulate distribution of transmission Power of all UWB-BAN nodes.



3. Derive permissible level of interfering Power in the PU terminal with strongest interference



4. Control transmission power of UWB -BAN nodes so as to make the received Interference less than the permissible level

Free Space Propagation f : frequency[GHz]
 D : distance [km]
 $P_{-l} = 92.44 + 20\log(f) + 20\log(D)$

Permissible Interference level due to radio regulation I_0 is derived
 $I_0 / N = -10[\text{dB}]$ I_0 : Interfering power
 N : noise power

All other PUs must be less interfered than the focused PU.

6.2.1 Proposed Transmission Power Control of UWB-BAN Using Cooperative Sensing with Integrated Terminal

Process

1. Acquiring location information of all terminal nodes, simulator is set up in integrated terminal



2. Simulate distribution of transmission Power of all UWB-BAN nodes.



3. Derive permissible level of interfering Power in the PU terminal with strongest interference



4. Control transmission power of UWB-BAN nodes so as to make the received Interference less than the permissible level

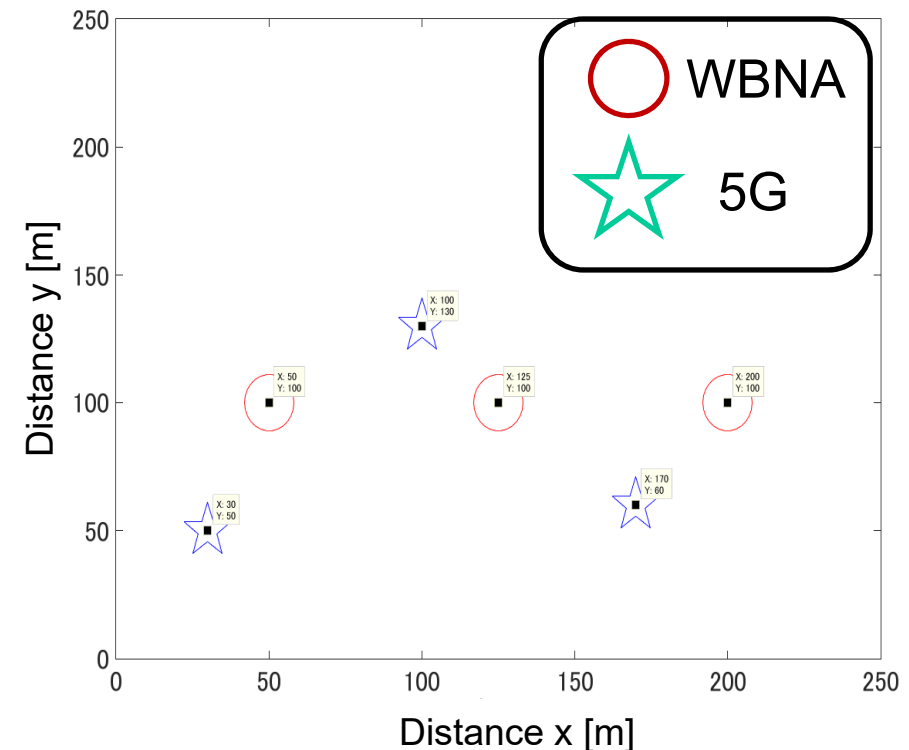

Location Map in Simulator

6.2.2 Proposed Transmission Power Control of UWB-BAN Using Cooperative Sensing with Integrated Terminal

Process

1. Acquiring location information of all terminal nodes, simulator is set up in integrated terminal



2. Simulate distribution of transmission Power of all UWB-BAN nodes.



3. Derive permissible level of interfering Power in the PU terminal with strongest interference



4. Control transmission power of UWB -BAN nodes so as to make the received Interference less than the permissible level

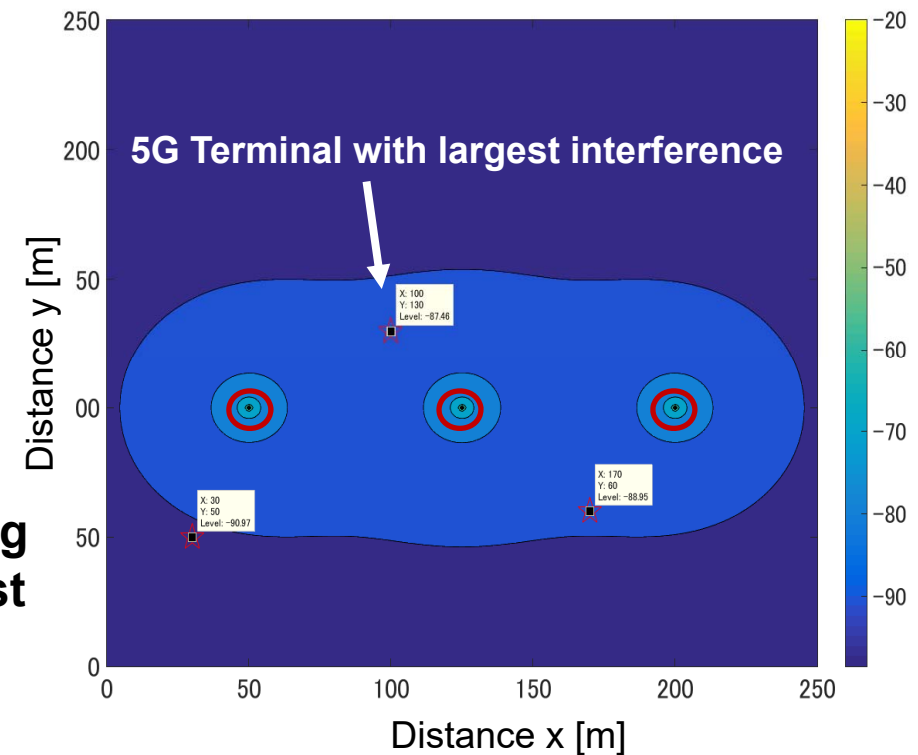

Location Map in Simulator

6.2.3 Proposed Transmission Power Control of UWB-BAN Using Cooperative Sensing with Integrated Terminal

Process

1. Acquiring location information of all terminal nodes, simulator is set up in integrated terminal



2. Simulate distribution of transmission Power of all UWB-BAN nodes.



3. Derive permissible level of interfering Power in the PU terminal with strongest interference



4. **Control transmission power of UWB-BAN nodes so as to make the received Interference less than the permissible level**

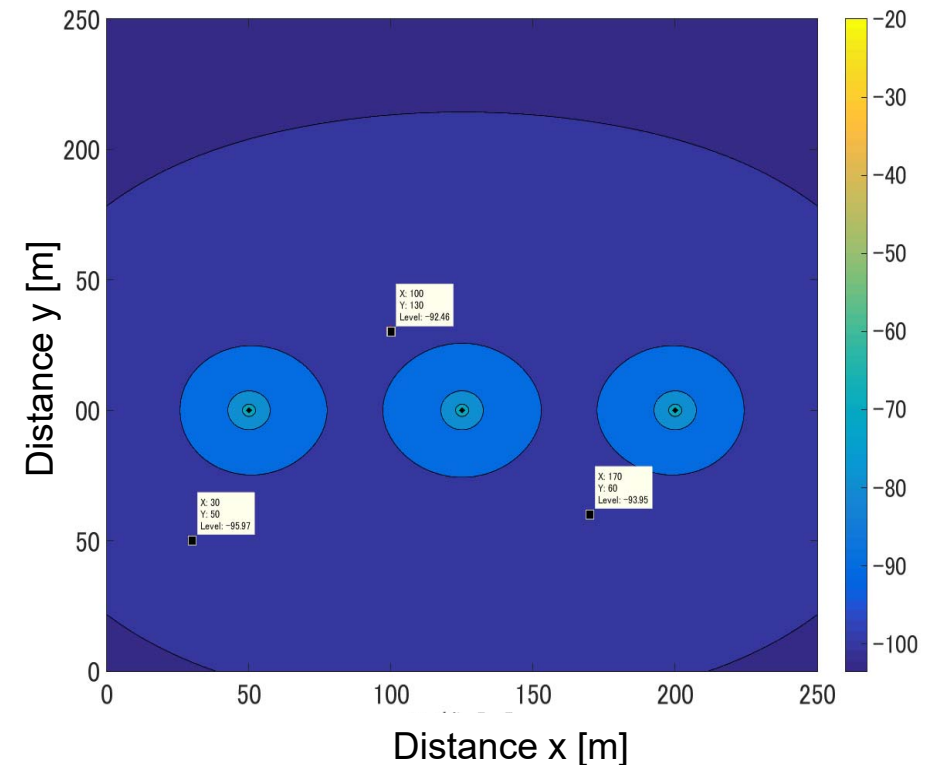

Location Map in Simulator

6.3 Frame structure of the Proposed Scheme

PU's frame structure: 5G terminal



SUs's frame structure: UWB-BAN

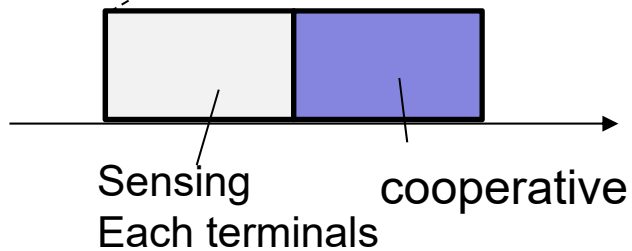
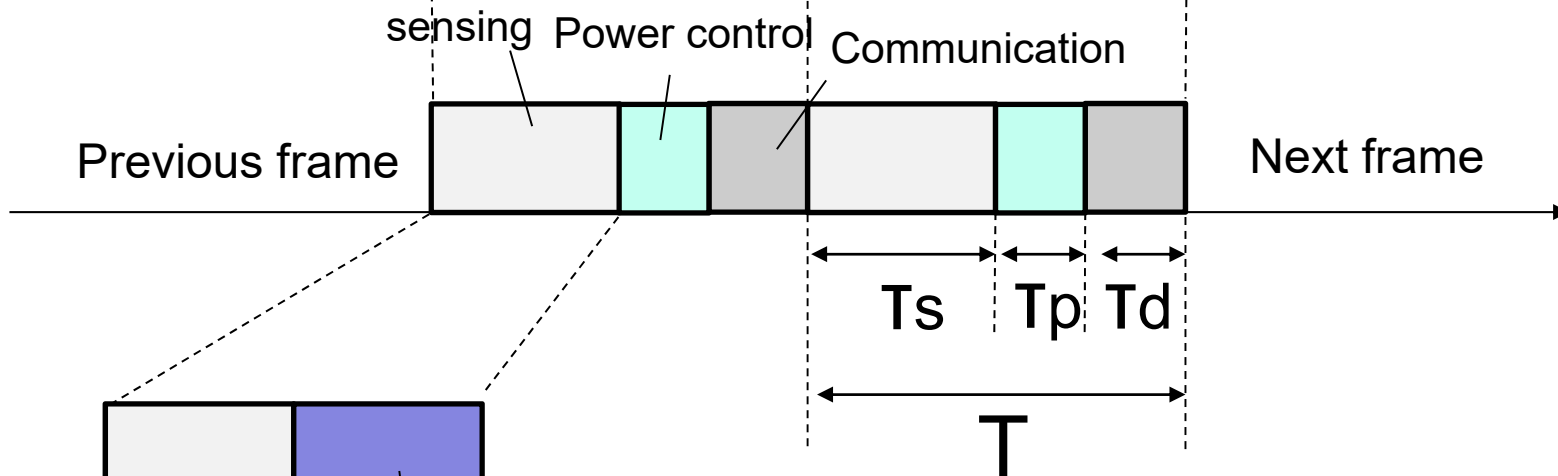

7. Performance Evaluation

7.1 System Model

- The system model of this thesis
- System flow my proposal method

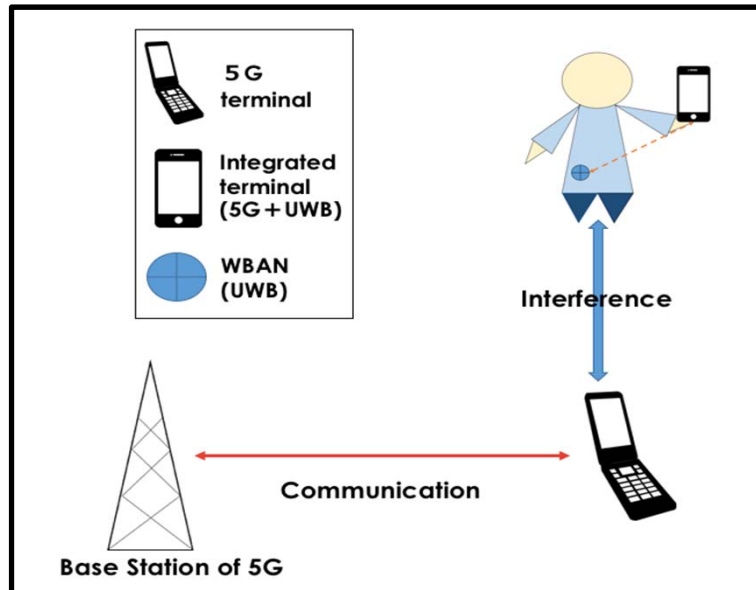

Fig 15 environment of this thesis

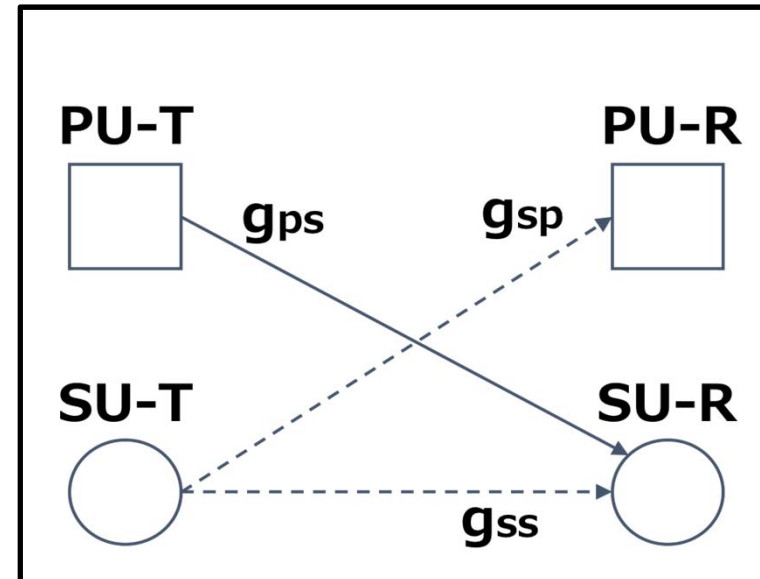

Fig 16 the system model of this thesis

7.2 Independent and Cooperative Sensing

Independent sensing an interfering power uses the following process

$$H_0: y(n) = w(n)$$

$$H_1: y(n) = A \cdot s(n) + w(n)$$

n: no. of samples W(n): average 0, variance of white noise σ_w
 A : received power according to distance

Received power derived from received signals

$$T = \sum_{n=0}^M |y(n)|^2$$

Comparison between T and threshold γ

If $T > \gamma$, then judge there is interference

If $T < \gamma$, then judge there is no interference

False Alarm Probability P_{fa} , Detection Probability P_d

$$P_{fa} = Q\left(\frac{\gamma - M\sigma_w^2}{\sqrt{2M\sigma_w^4}}\right) \quad P_d = Q\left(\frac{\gamma - M(\sigma_w^2 + \sigma_x^2)}{\sqrt{2M((\sigma_w^2 + \sigma_x^2))^2}}\right)$$

Cooperative sensing Process

Judgement result of each PU
 Is described 1,0.

Total number of the judgement is
 used of decision

$$D(i) = \begin{cases} 1 & (\text{signal exist}) \\ 0 & (\text{no signal}) \end{cases}$$

Decision rules

- ① OR rule
- ② AND rule
- ③ Vote rule

In case OR-rule

$$P_{fa}^{OR} = 1 - (1 - P_{fa})^N$$

$$P_{df}^{OR} = (P_{df})^N \quad N: \text{no. of nodes}$$

7.3 Simulation Specification

- Evaluating throughput of UWB-BANs and False Alarm Probability
- In case of close location between UWB-BAN and 5G nodes (1m) ← Strongest Interference
- In case of far location between 5G BS and UWB-BAN node (100m) ← Worst sensing accuracy

- Location of nodes is fixed
- Receiving SNR of PUs is fixed
- Assuming free space propagation

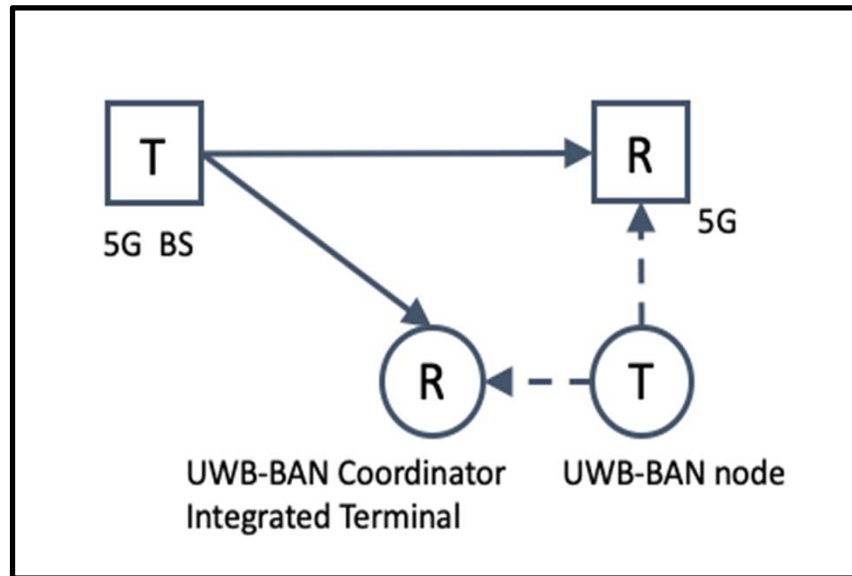
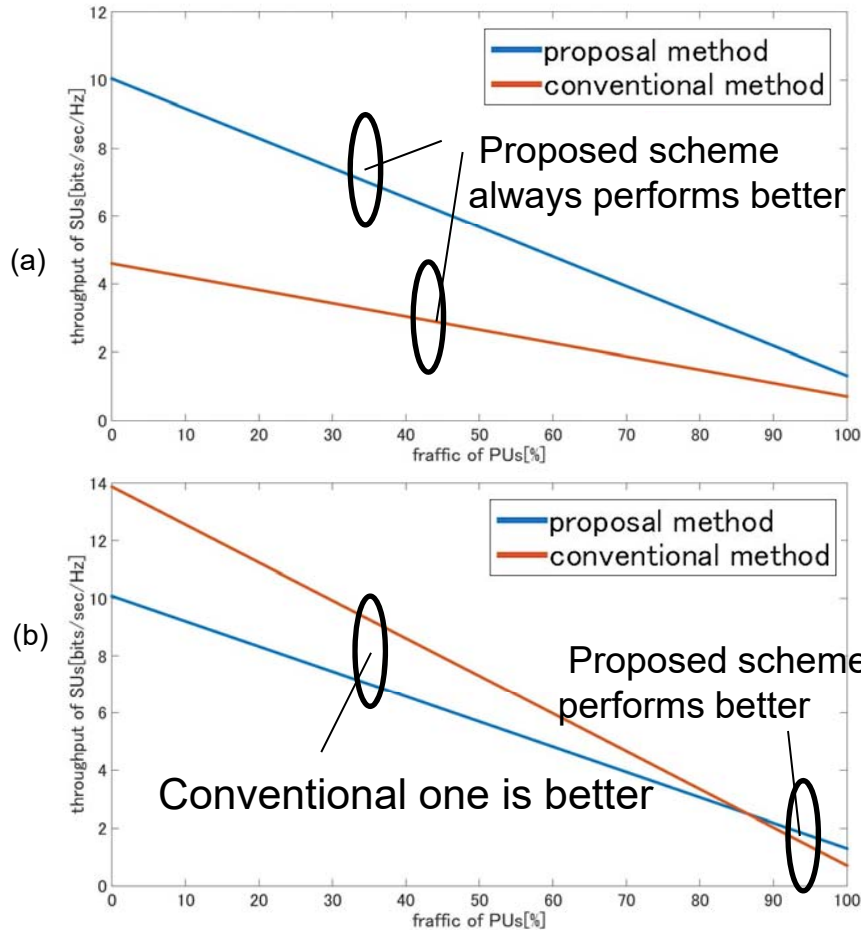

Fig. 17 Layout of simulation model

Table 2 Specification

Items	Values
No. of Pus and Sus	1
Bandwidth of Sus	500[MHz]
Received SNR in PUs	0 or 5[dB]
Central frequency in PUs	3.5[GHz]
Maximum transmission power in SUs	-41.3[dBm/MHz]
Signal attenuation in SUs [1m]	43.8[dB]
Desired detection probability Pd	0.95
Noise	AWGN
Frame length	100[ns]
Sensing time period	30[ns]
Tx power control period	20[ns]

7.4 Evaluation of Throughput in case of close location between 5G and UWB-BAN terminals 1m



In case of low SNR of 5G → low accuracy of sensing

Conventional scheme has high false alarm probability → low Throughput

Proposed scheme has low false alarm probability → high throughput

In case of high SNR of 5G → high accuracy of sensing

Due to low false alarm probability, throughput keeps high

	5G received SNR = 0[dB]		5G received SNR = 5[dB]	
Close	Pfa_con=0.67	Pfa_pro=0.01	Pfa_con=0.01	Pfa_pro=0
Far	Pfa_con=0.94	Pfa_pro=0.92	Pfa_con=0.92	Pfa_pro=0.74
Middle	Pfa_con=0.23	Pfa_pro=0.01	Pfa_con=0	Pfa_pro=0

Fig 18 Throughput of SUs according to Traffic of PUs
Upper (a) 5G's SNR = 0[dBm], Lower (b) 5G's SNR = 5[dBm]

7.5 Evaluation of Throughput in case of far location between 5G and UWB-BAN terminals 100m

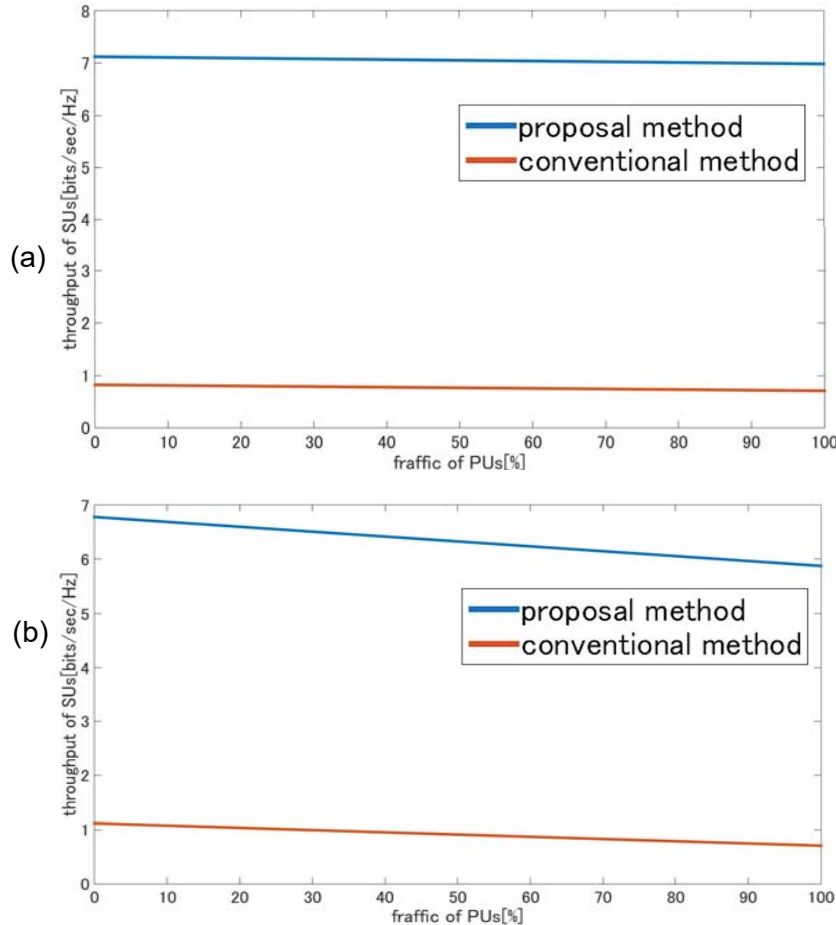

Although conventional scheme has low throughput due to high false alarm probability in case of far location between 5G BS and UWB-BAN, the proposed scheme can improve throughput of UWB-BAN because the proposed can keep adjusting transmission power appropriately.

	5G received SNR = 0[dB]		5G received SNR = 5[dB]	
Close	Pfa_con=0.67	Pfa_pro=0.01	Pfa_con=0.01	Pfa_pro=0
Far	Pfa_con=0.94	Pfa_pro=0.92	Pfa_con=0.92	Pfa_pro=0.74
Middle	Pfa_con=0.23	Pfa_pro=0.01	Pfa_con=0	Pfa_pro=0

Fig 19 Throughput of SUs according to Traffic of PUs
Upper (a) 5G's SNR = 0[dBm], Lower (b) 5G's SNR = 5[dBm]

8. Conclusion

- According to trend of 5G, IoT/M2M, and increase of WBAN application beyond medical BAN, their overlapped coverage range of these networks will increase.
- UWB radio regulation in Japan was updated to promote its more applications.
- In order to solve such a problem, a new scheme of controlling transmission power of UWB-BANs has been proposed to avoid interference to 5G terminals overlapped in coverage range.
- Current standard IEEE802.15.6 for WBAN should be updated to apply this proposed scheme in physical layer to solve a coexistence problem between primary user 5G and secondary user UWB-BAN.

Thank you for your attention