

FastSpot: From Channel Sounding to the System Implementation and Demonstration at 200 GHz

Authors:

Date: 2019-03-13

Name	Affiliation	Address	Phone	Email
Robert Müller, Diego Dupleich, Giovanni Del Galdo, Reiner Thomä,	Technische Universität Ilmenau			Mueller.Robert@tu-ilmenau.de Reiner.thomae@tu-ilmrnau.de
Panic Goran	IHP			panic@ihp-microelectronics.com
Corrado Carta	Technische Universität Dresden			corrado.cart@tu-dresden.de

Abstract

In this presentation, we give an overview about the terahertz project “fastSpot”. We like to present our current activities in THz channel sounding and modelling for 200 GHz indoor scenarios. Another interesting point is the status of a fully integrated 200 GHz communication system, and the results of the first tests.



>20 Gb/s drahtlos

Outline

- The THz project “fast Spot”
- Multi-Band channel sounding from microwave to terahertz
- Indoor measurements and modelling activities at 200 GHz
- 200 GHz system developments in the frame of “fast Spot”
- Conclusion

The THz project “fastSpot”

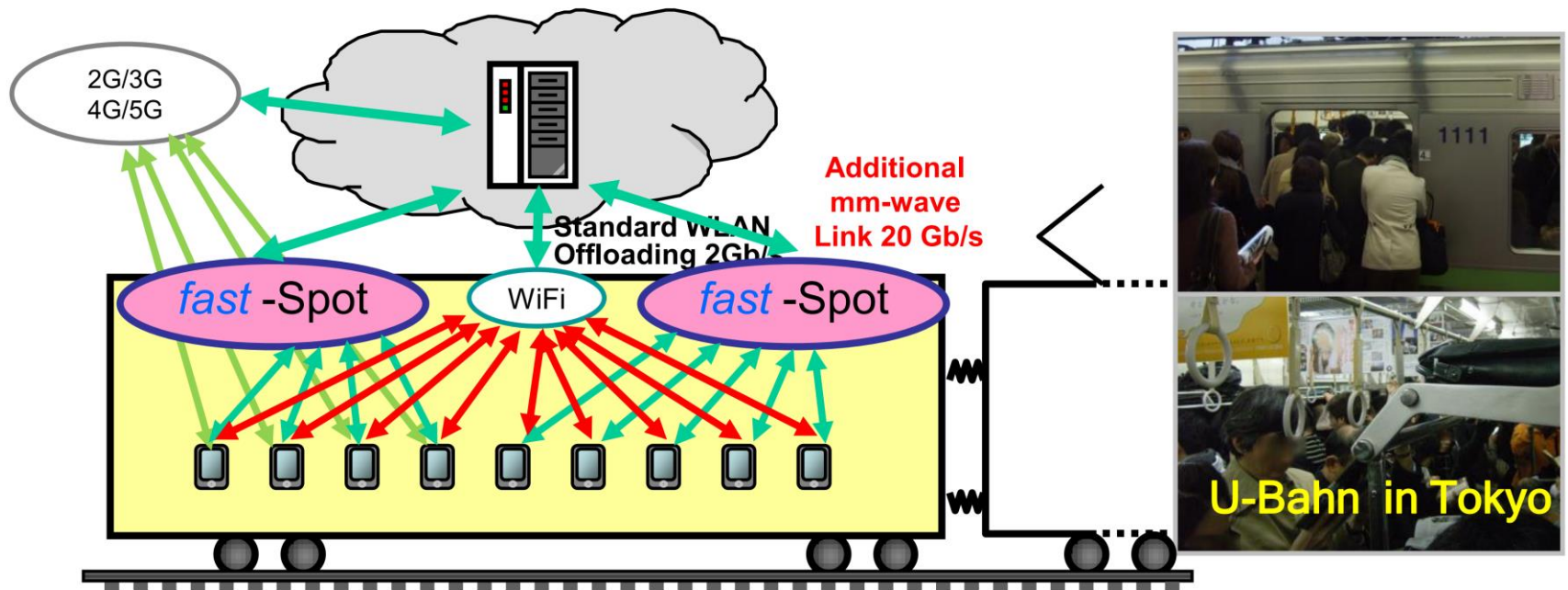

For very crowded situation like Subways, Bus, Concerts etc.

Overview BMBF Project “fastSpot”

- Development of ultra-fast access points at around 200 GHz with a BW > 20 GHz
- Channel characterization + modeling at 200 GHz for small/medium size Indoor scenarios
- Dynamic real-time antenna control using analogue vector modulators with high directivity (> 30dBi) and integrated beamforming antennas
- Location of the participants by radar / ranging technology
- Space multiplex technology (BDMA) with multiple beam (up to 5 beams simultaneously)
- latency <1ms by real-time multiplexing (SDM + TDM + FDM)
- Modular baseband technology based on multi-core baseband processor
- 28 nm (or 40 nm) GF-CMOS technology (supplied by fast-access)
- 1-5 Gb / s / subscriber (20 * 1 Gb / s to 4 * 5 Gb / s) can be cascaded
- Standard conform IEEE802.2 LLC technology allows direct integration into any HotSpot configuration

fastSpot Project Status

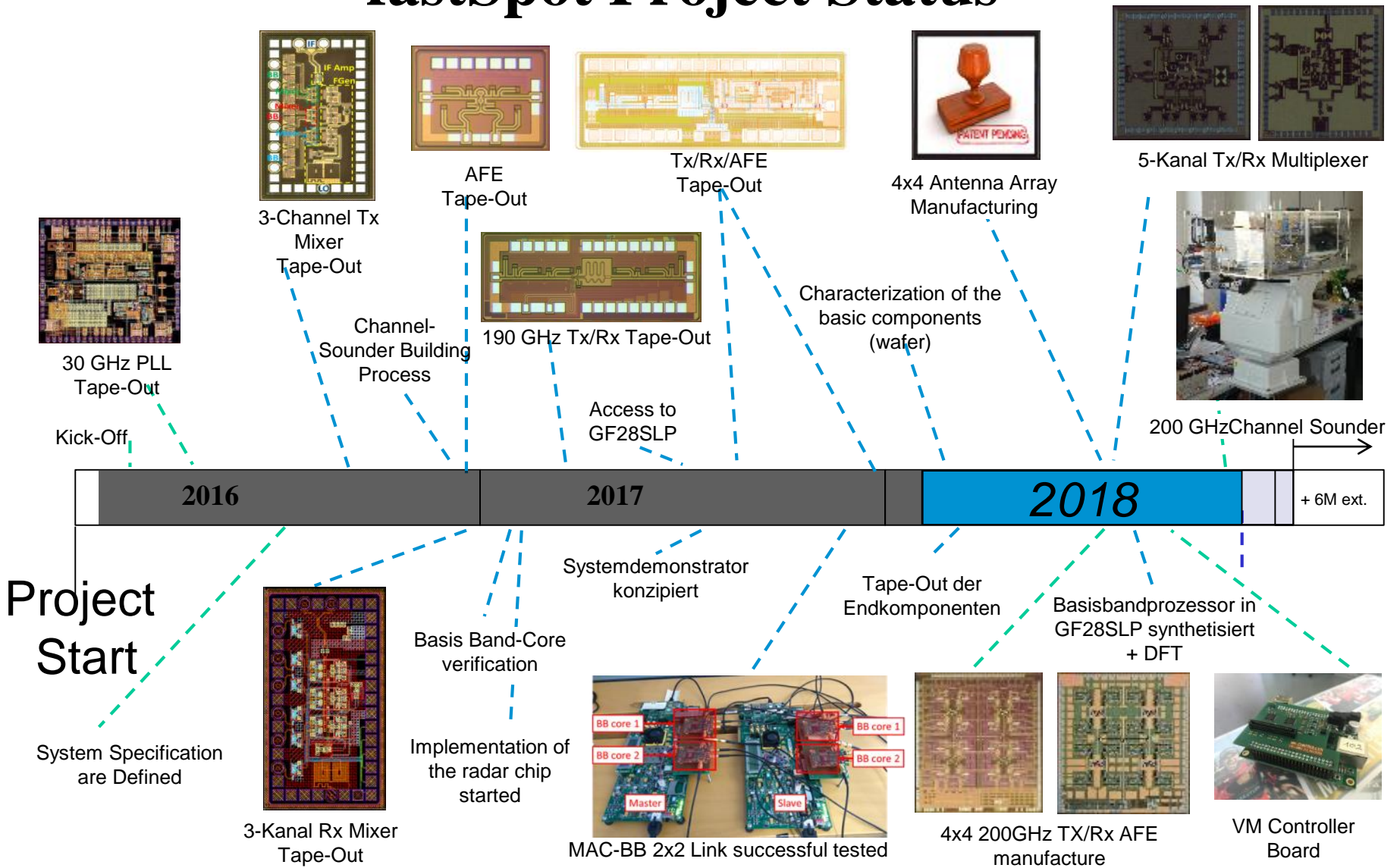

**Multi-Band Channel Sounder
from
Microwave to Terahertz**

200 GHz Converter Part

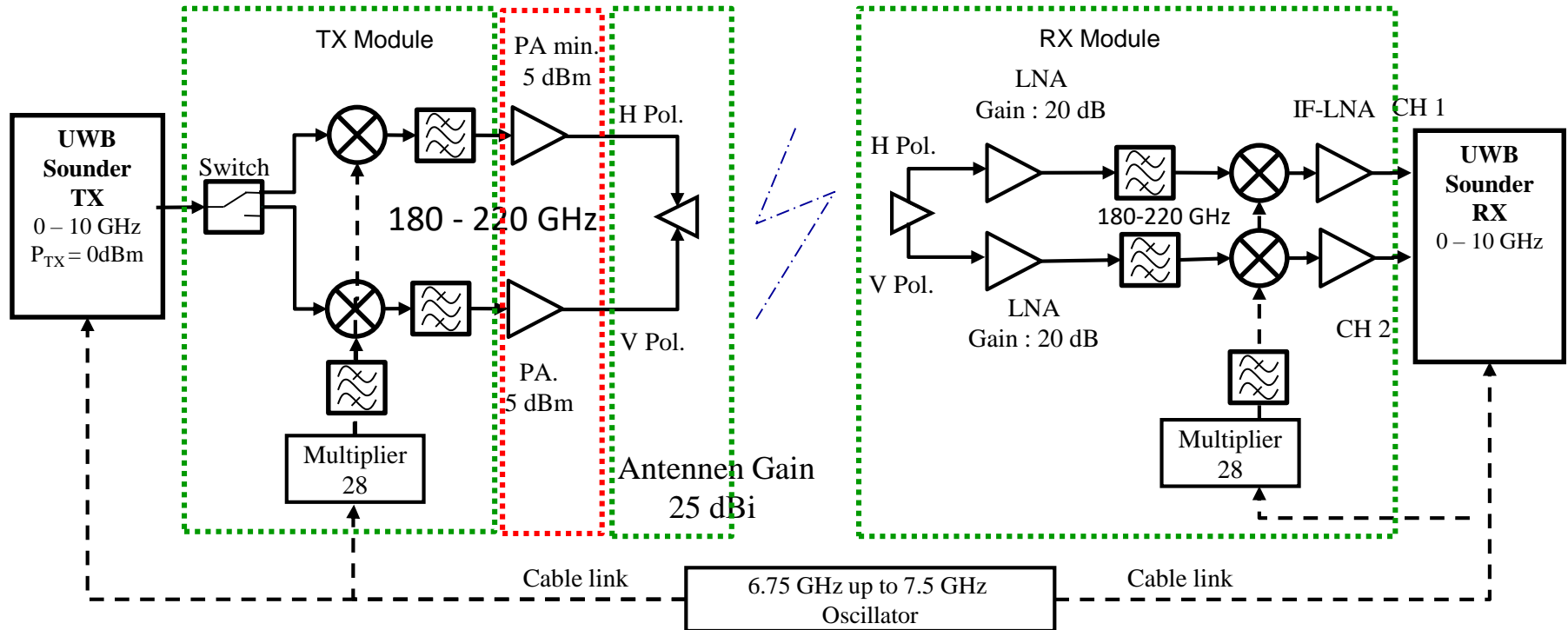

- The green parts show the commercial components of the 200 GHz Channel Sounder
- Red part is now under development in cooperation with IHP and TU Dresden
 - PAs will be packaged in LTCC with a waveguide connection
- Dual polarized channel sounder system
- Clock Frequency can be located between 6.5 GHz to 8 GHz → 180-240 GHz

Multi-Band Measurement Setup

- Three of the follow bands can be combined as desired (3-10 GHz, 71-78 GHz and 180-210 GHz)
- Antennas can occupy exactly the same position (only for two frequency bands at the same setup)
- Comparison of the propagation characteristics at different frequencies with the exactly same conditions
 - The only Channel Sounder with this feature
- Reduce of the measurement time
- Phases coherent and phase stable measurements
 - calculation of synthetic aperture
 - After Calibration HRPE is possible



Indoor Measurements and Modelling Activities at 200 GHz

Meeting Room Scenario

Dimensions:

4m x 12m x 3m

- Part disguised wood

Status:

- Measurements are done
- Currently we calibrate the RT
- Analysis of Different Antenna concepts in the RT model
- RT will be calibrate for 3-10, 30-37,60-67, 71-78 and 180-220 GHz

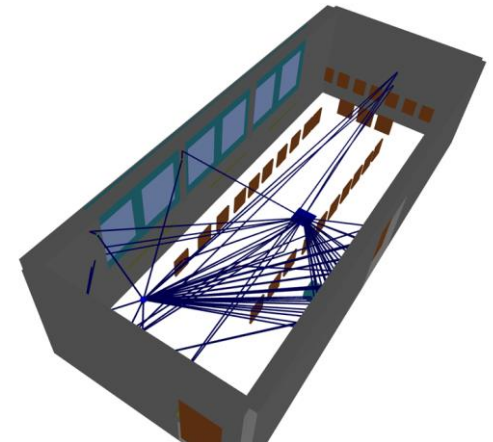
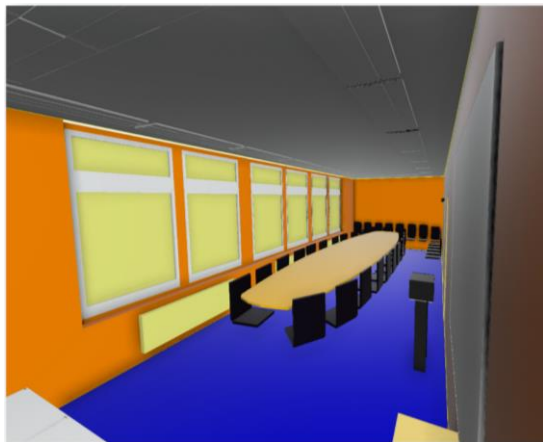
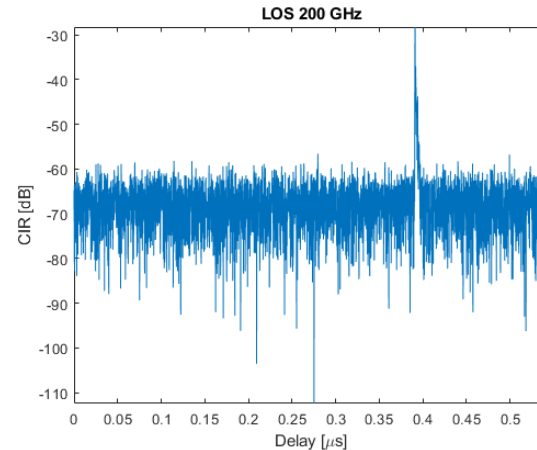

Simulations in a Realistic Environment

Scenario

- Conference room at the TUIL
- LOS AP to UE scenario: AP located in roof at 2.8m height, UE at 1m height

Ray Tracing

- 20 paths per position
- 4x4 Tx array
- Omni Rx

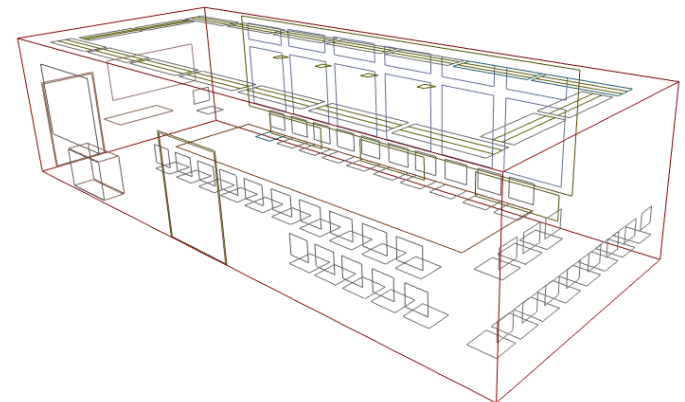
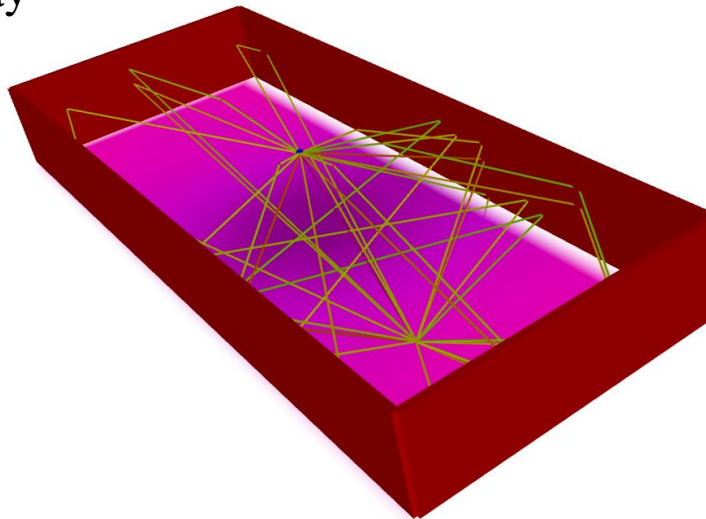

Link Budget

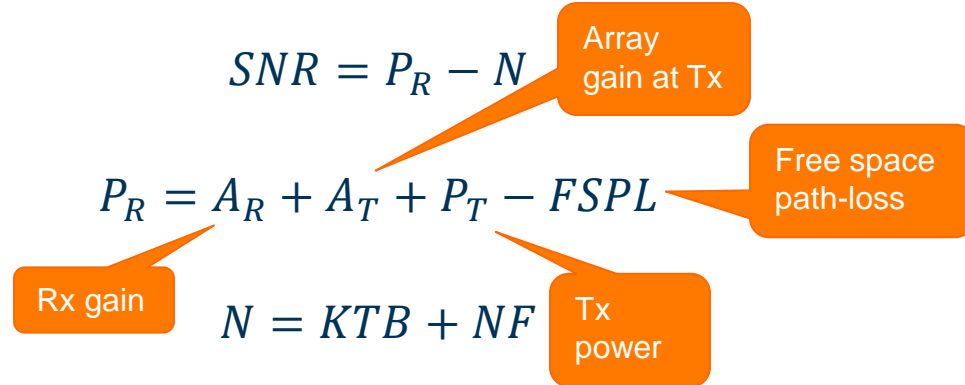

$$SNR = \underline{0\text{dBi} + 16\text{dBi} + 10\text{dBm} - 94.59\text{dB}} - (\underline{-73.88\text{dBm} + 6\text{dB}})$$

$$= -0.71 \text{ dB}$$

Worst case w/o Rx gain

	Value
Bandwidth	10 GHz
Tx Power	10 dBm
Array Gain Tx (4x4)	16 dBi
Gain at Rx	0 dBi
Max FSPL* (6.74 m)	94.59 dB
Noise Power (10 GHz BW)	-73.88 dBm
Rx Noise Figure	6 dB

Beamforming Strategies

Three different strategies

1) No steering

Array pointing to the boresight or with a fixed single steering direction

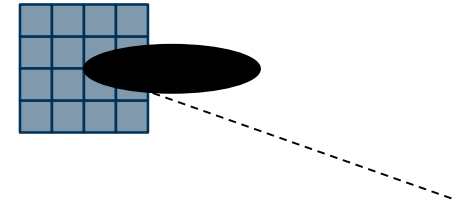

2) Beam-steering (fixed beams [FB])

Set of pre-defined coefficients for beams pointing in different directions. The strongest beam per position is selected

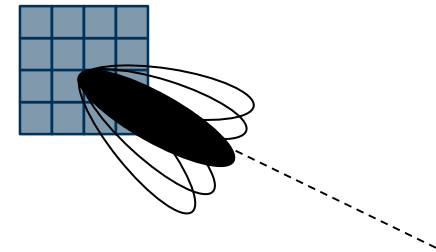

3) Beam-steering (flexible steering)

Plain beam-steering in the LOS direction

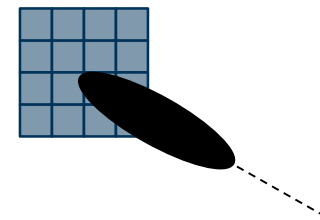

Simulated fastSpot Phase Array

- Simulated 4x4 array on the XY plane
- Severe coupling effects
- Simulations for a single frequency component at 190 GHz

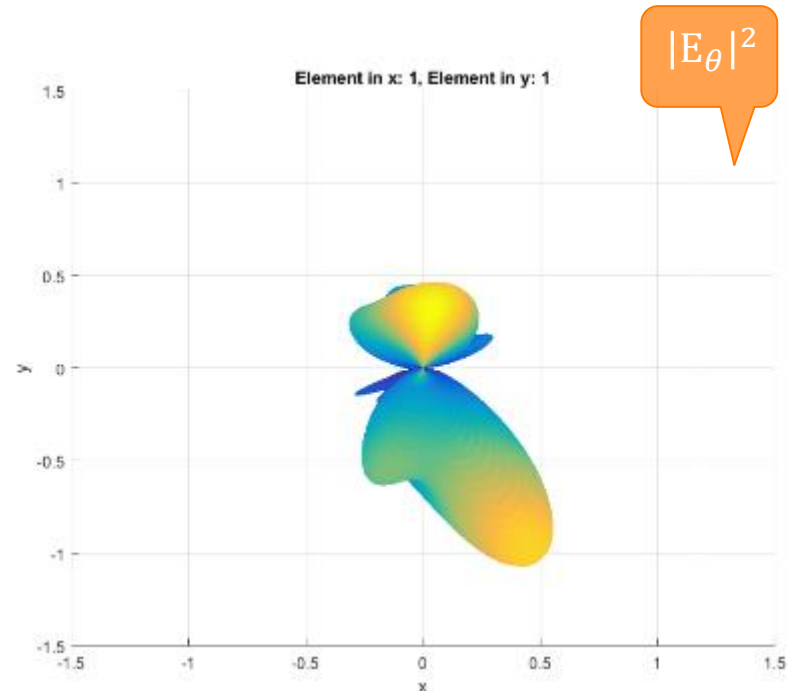
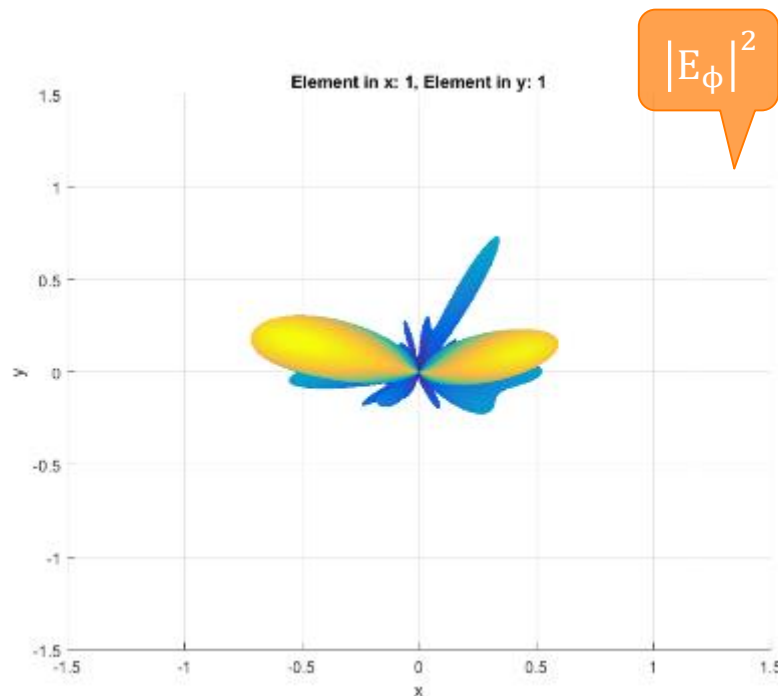

Beamforming (BF) Response

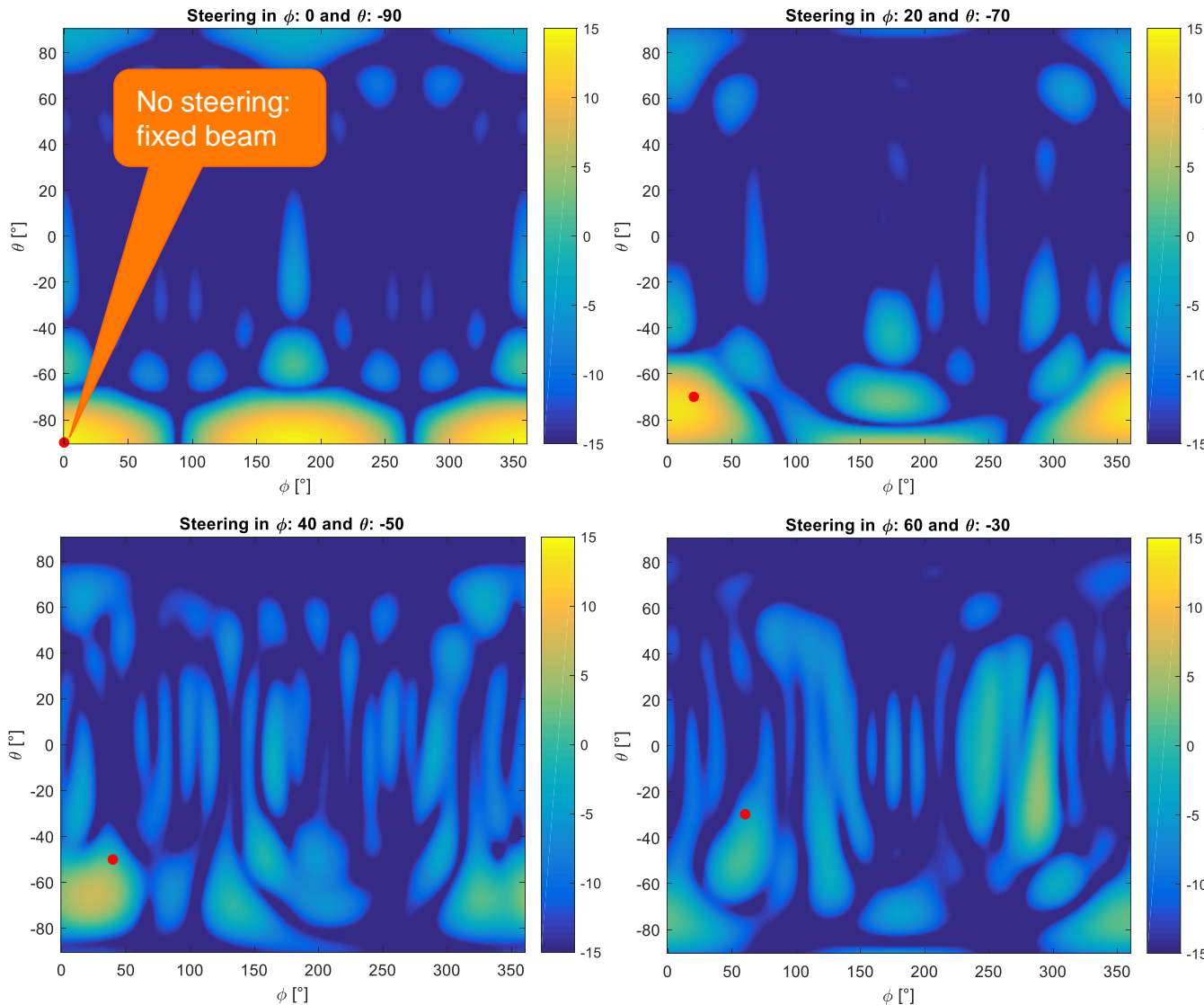

Phase shifting without considering the antenna response

Beamforming (BF) Response

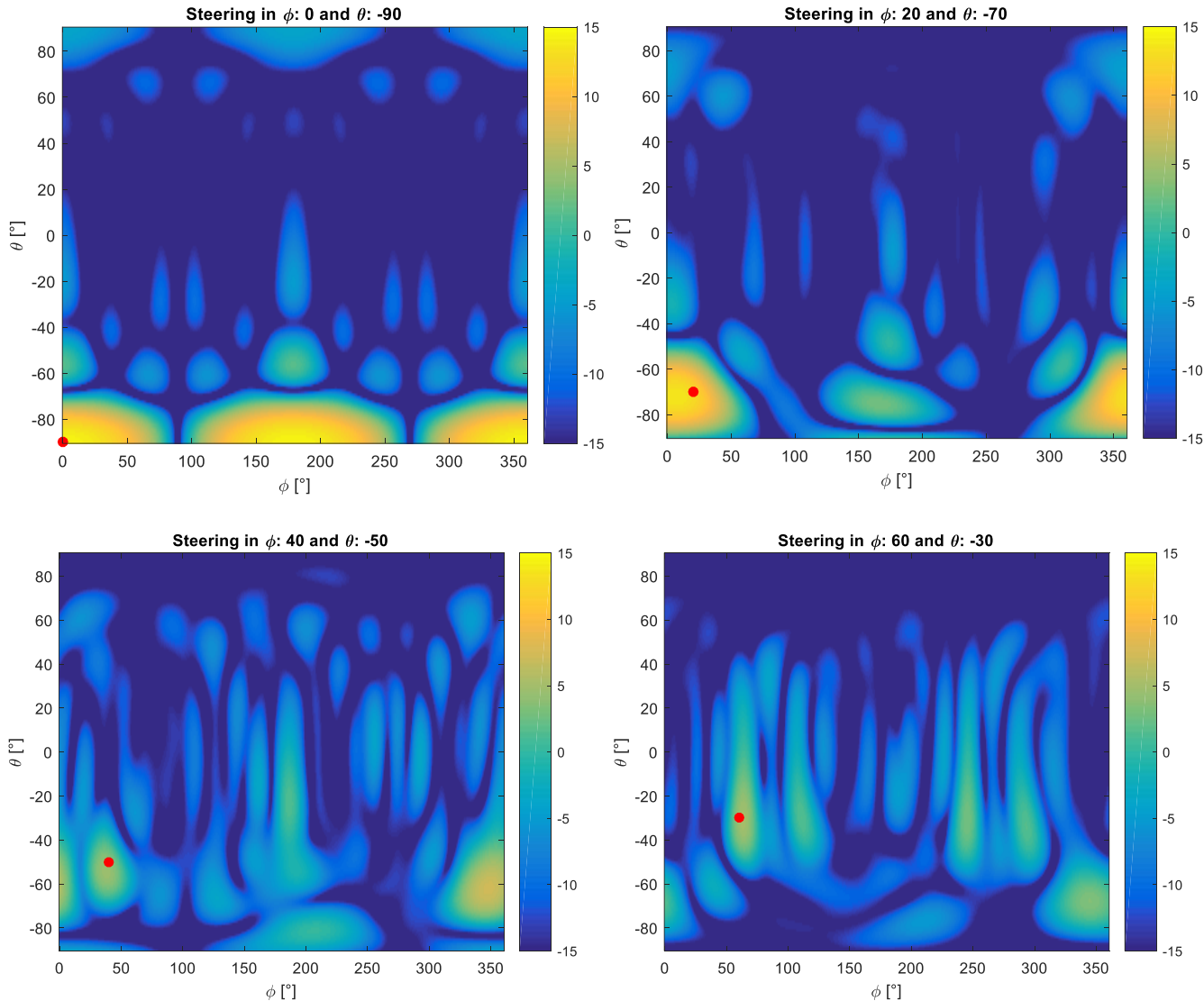

MRC(maximum ratio combining): we need to know the antenna response \rightarrow higher complexity on channel estimation required

Beamforming Response

Comparison of different BF algorithms

Low gain after steering

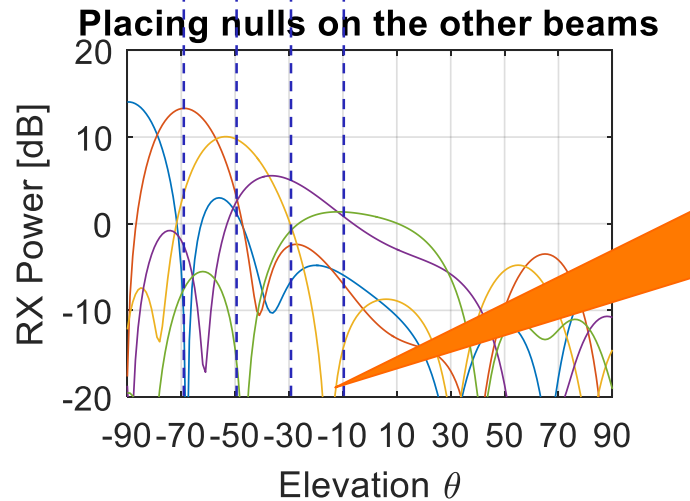
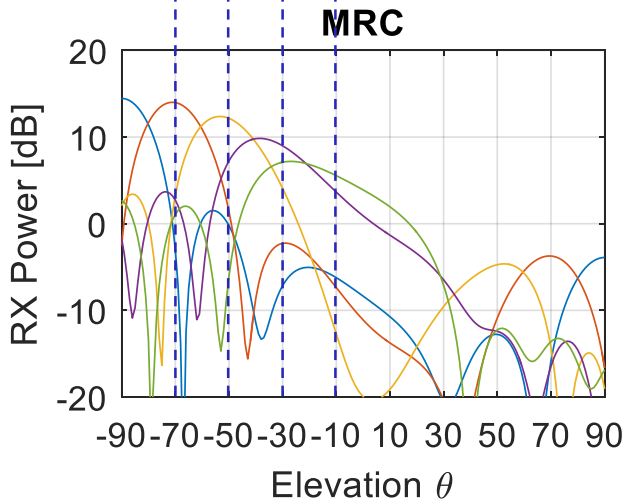
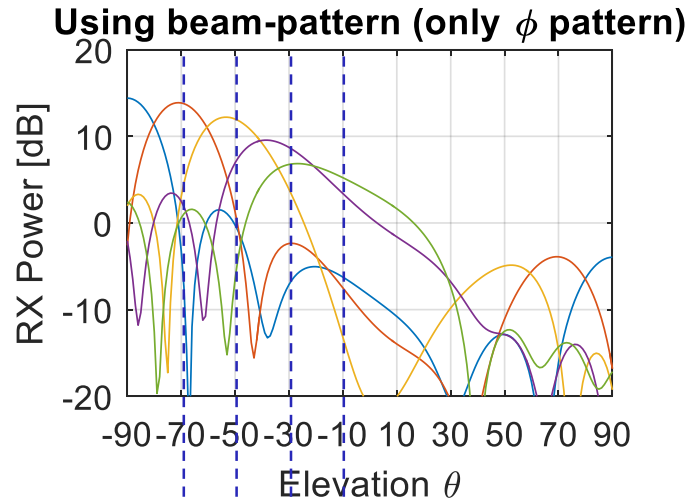
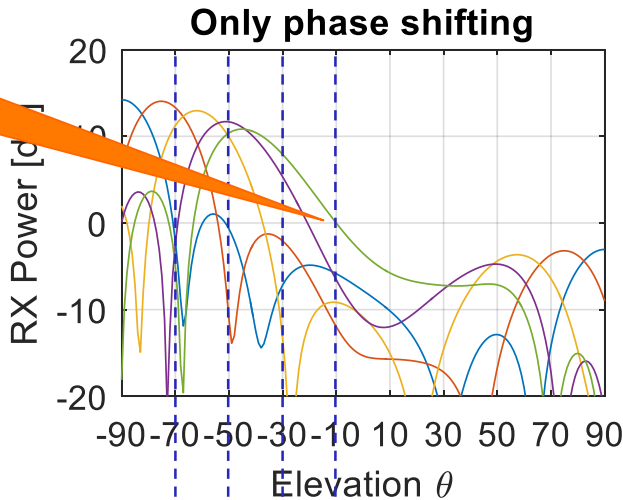

Reduces interference to other users, but achieves less gain

Simulation Results Different Algorithms and Strategies

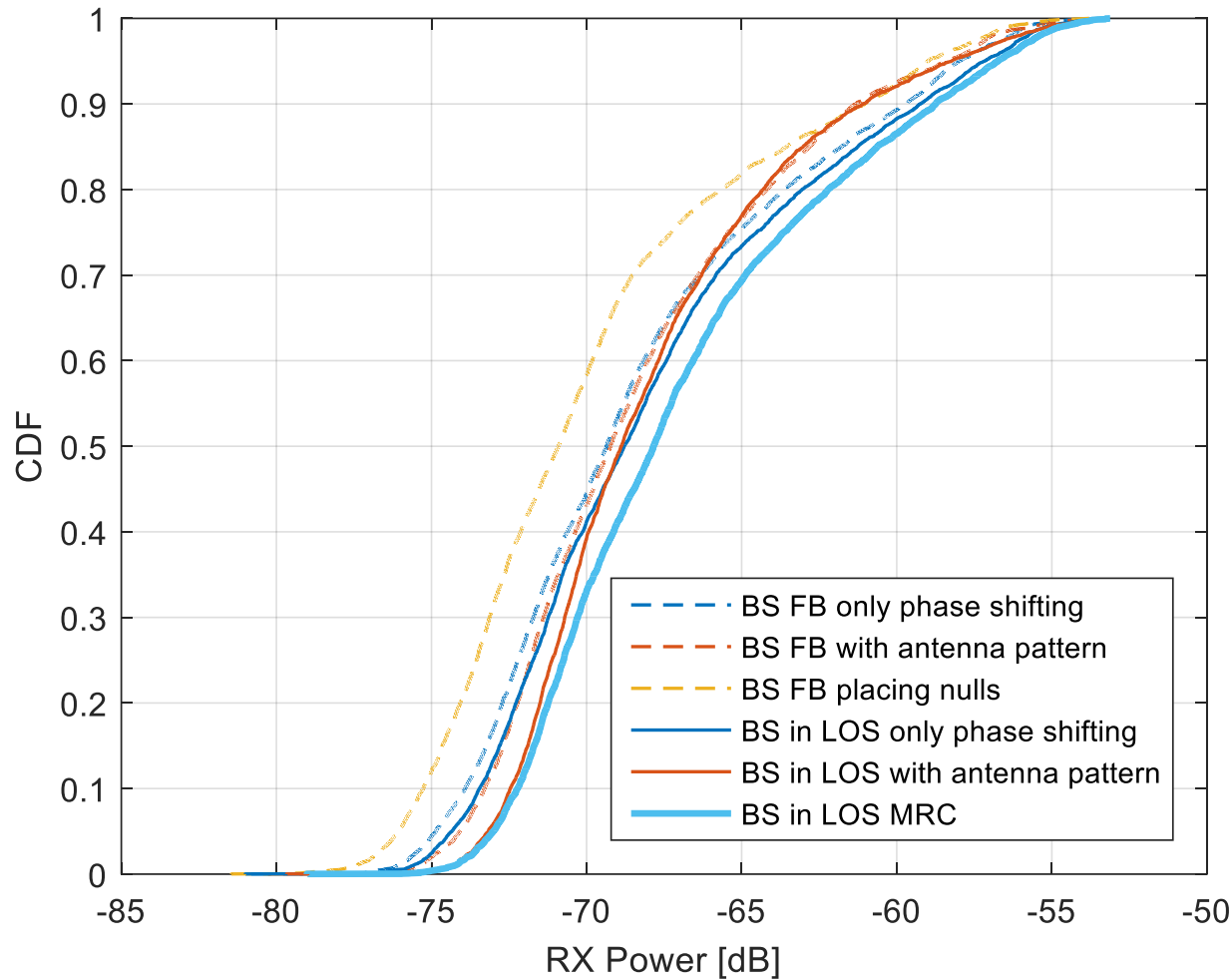

SNR Analysis in the Meeting Room Scenario for the fastSpot System

Distribution in the room

- Considering all the positions
- The different between Beam steering and switching is only 3dB with 30° steps in the angular domain

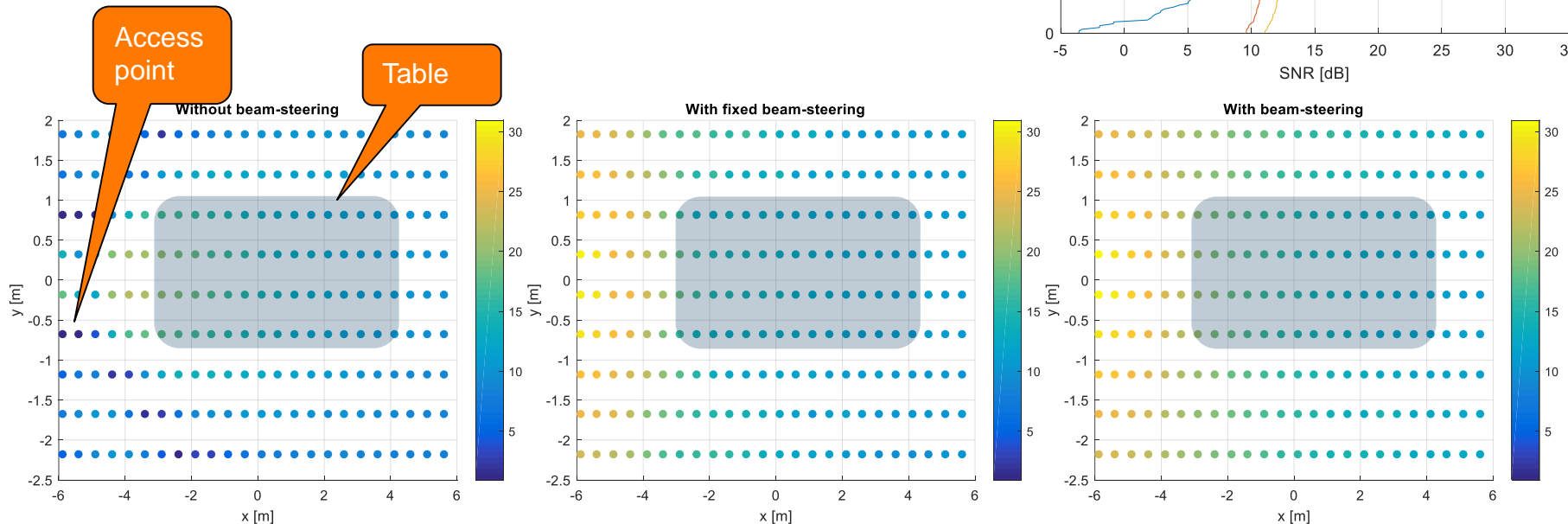

SNR Evolution Along a Moving Person Track

1. Considering the movement of a person start from 0 m to 12 m in 0.5 m steps
2. The fix beam is aligned with the front edge of the table

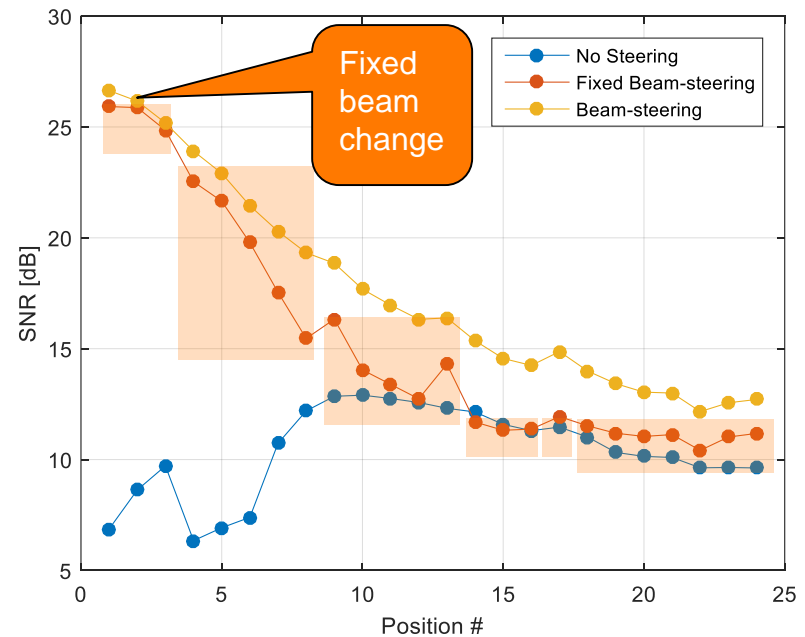
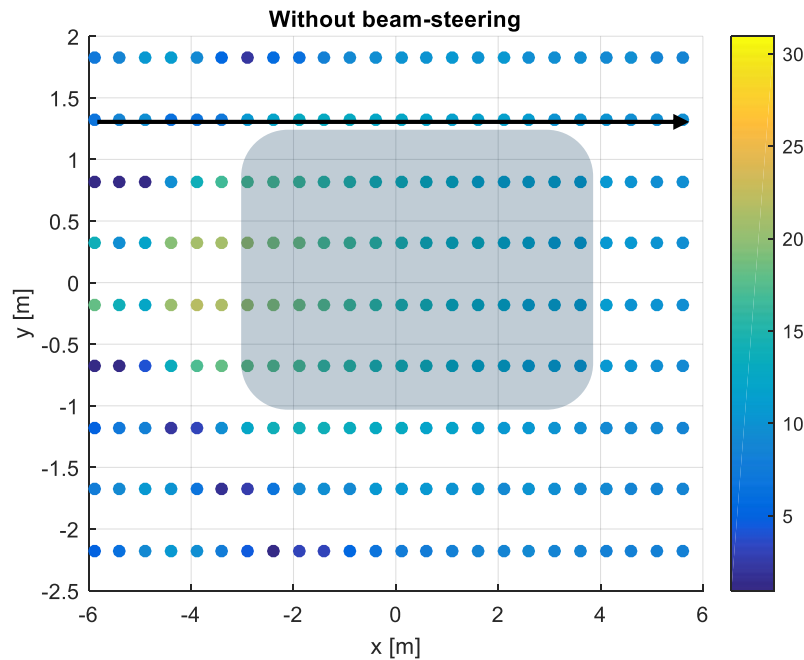

RX Power Along a Track

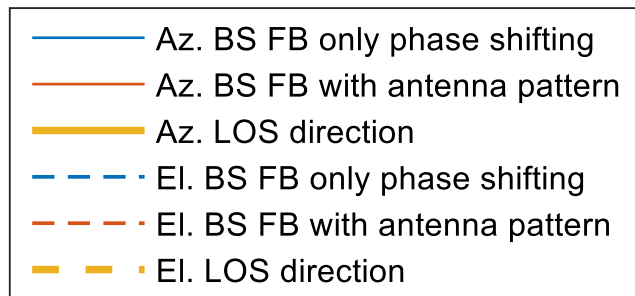
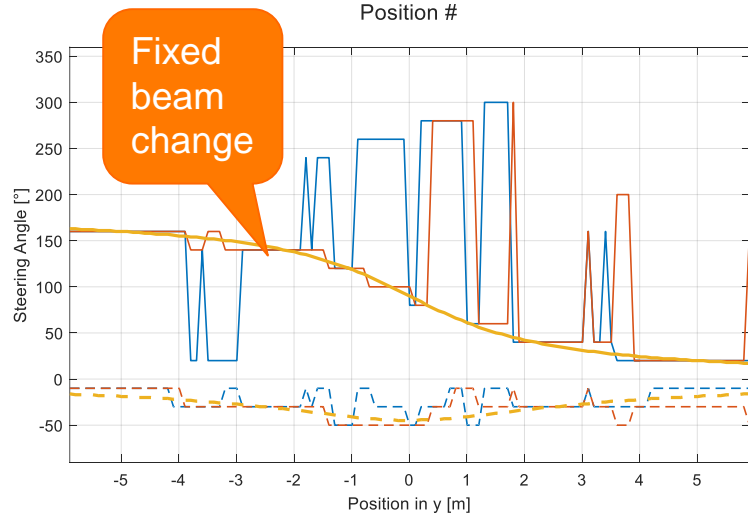
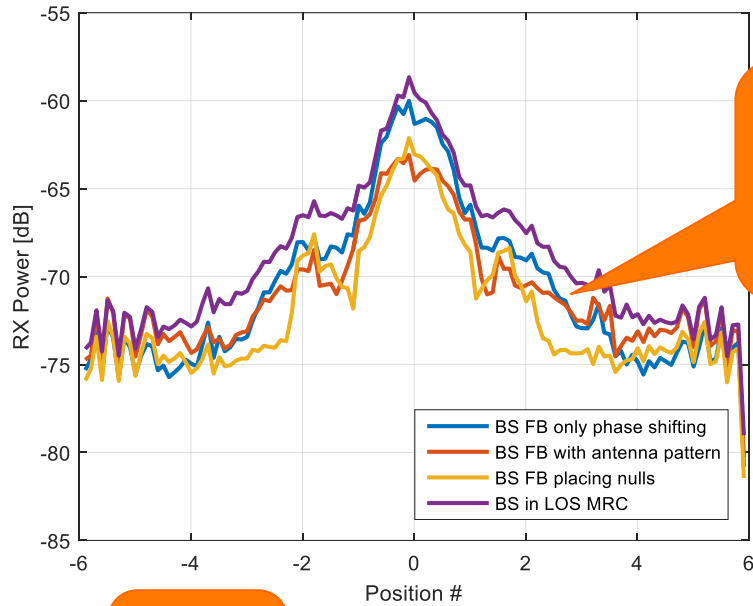

Entrance Hall Scenario

Dimensions:

7m x 25m x 9m

- Glass and metal
- 3 different floors

Status:

- Measurements at 200 GHz start at April 2019
- Analysis of Different Antenna concepts in the RT model
- RT will be calibrate for 3-10, 30-37,60-67, 71-78 and 180-220 GHz

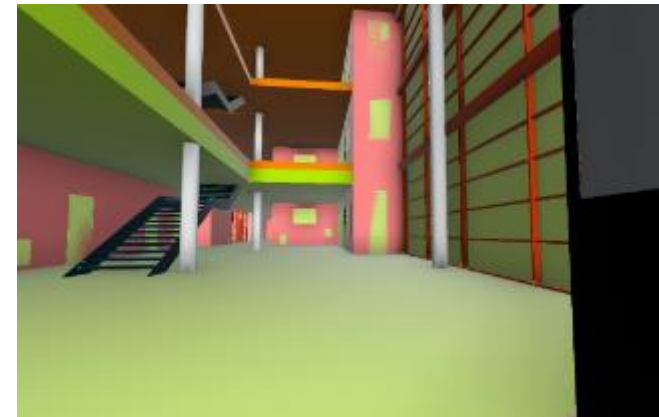
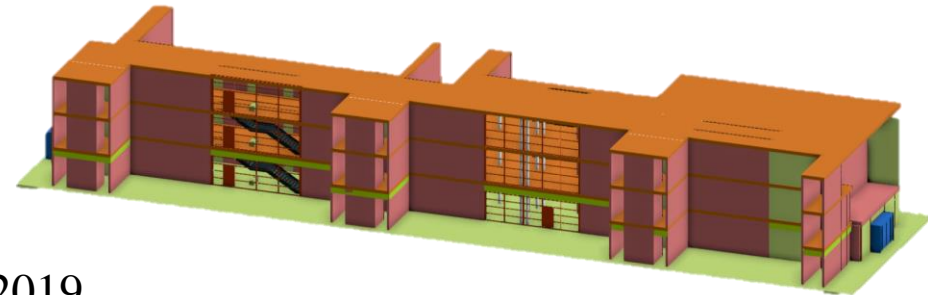

200 GHz
System Developments in the Frame of
“fastSpot”

THz Components Highlights from fastSpot

In the project is developed all from base band to RF

- High precision PLL at 30 GHz
- LNA`s with 20 dB gain
- PA`s with up to 10 dBm output power
- Broadband mixer`s at 200 GHz with ab bandwidth >40 GHz
- 200 GHz vector modulator for beamforming antenna arrays
- Integration in a full integrated 16 channel receiver and transmitter chip
- Antenna Array on SiGe

Base Band IF Multiplexer/Demultiplexer

Measurement results for the 3-channel Tx-Channelizer

Specification / I or Q channel	Target	Meas.	Unit	Comment
Gain	-8	-15	dB	6 dB difference comes from the 50 ohm load
Output referred noise	6.2	--	nV/sqrt(Hz)	To keep SNR=30dB (based on link budget) Simulated=4.5
Output P1dB Compression	-18	-20	dBm	This will be adjusted when gain is increased
BB Bandwidth	0.264*	> 4	GHz	The design will target higher channel BW's
RF Bandwidth	1-16	1-15	GHz	Lower bandwidth due to lower measure quality factor for combining structure
LO to RF Isolation	30	> 45	dBc	
Power Consumption	--	357	mW	

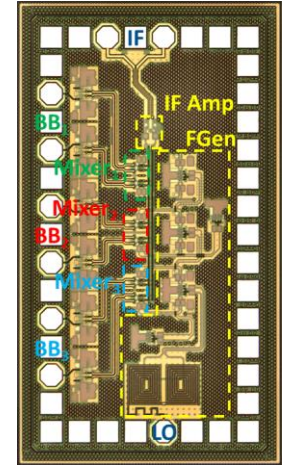
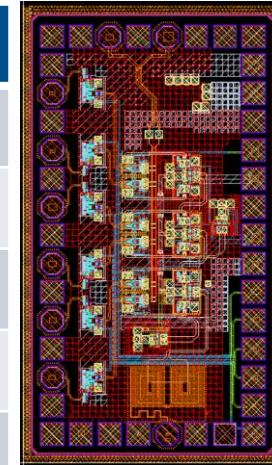

Measurement results for the 3-channel Rx dechannelizer

Specification	Target	Measured (On wafer)	Unit
Gain	12.5	11.5	dB
RF 3-dB Band width	>16	15	GHz
BB 3-dB Band width	>0.528	>1	GHz
Input P1dB	-7	-6.5	dBm
Output Swing	600	632	mV-pp
Noise	0.63	--	uV/sqrt(Hz)



200 GHz LNA – Measurements

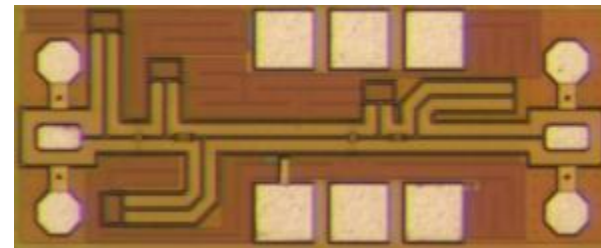
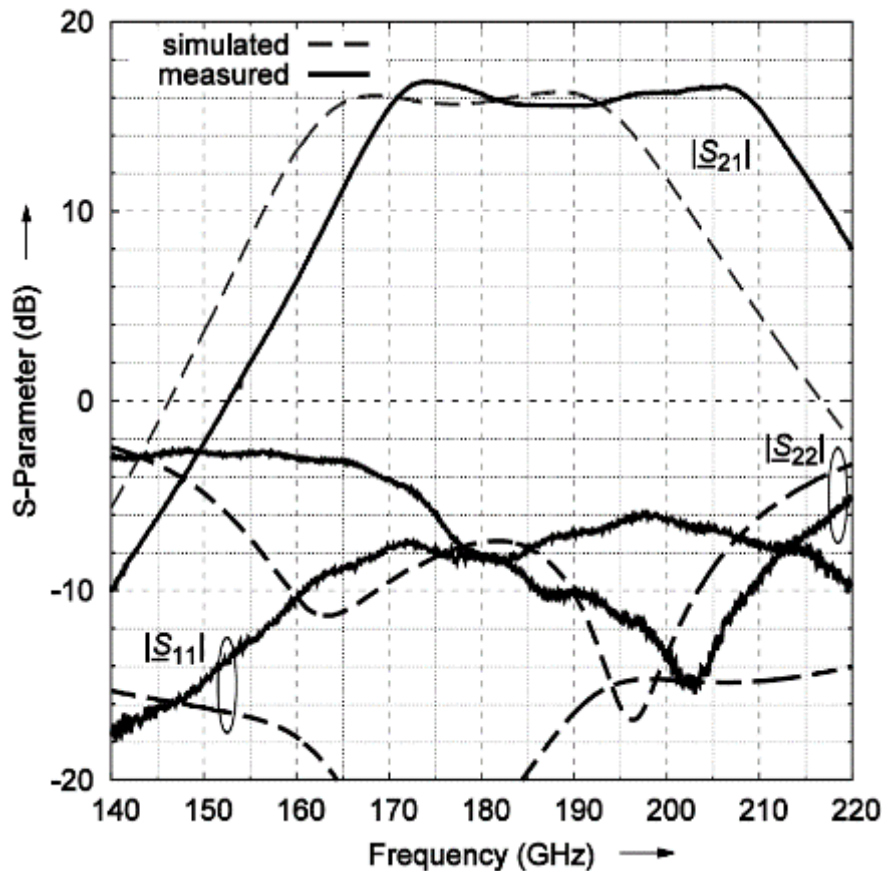

@ $V_{CC} = 2.0 \text{ V}$, $I_{CC} = 9 \text{ mA}$

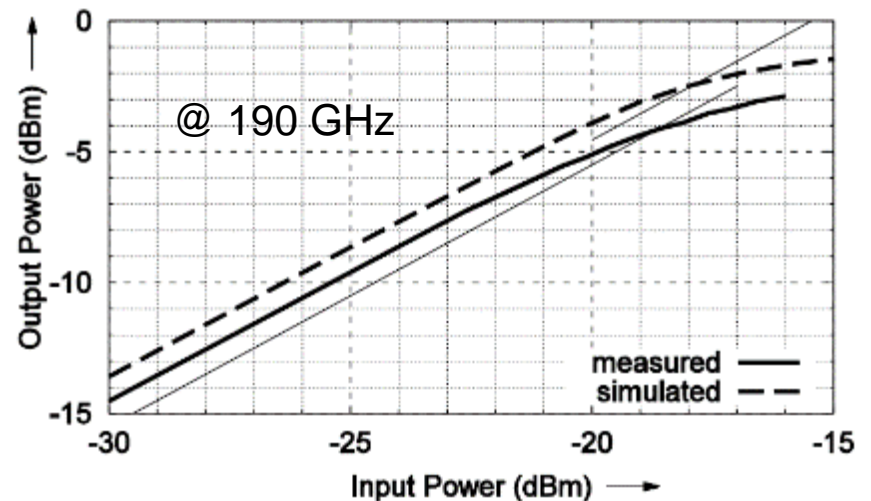

200 GHz Mixer – Measurements

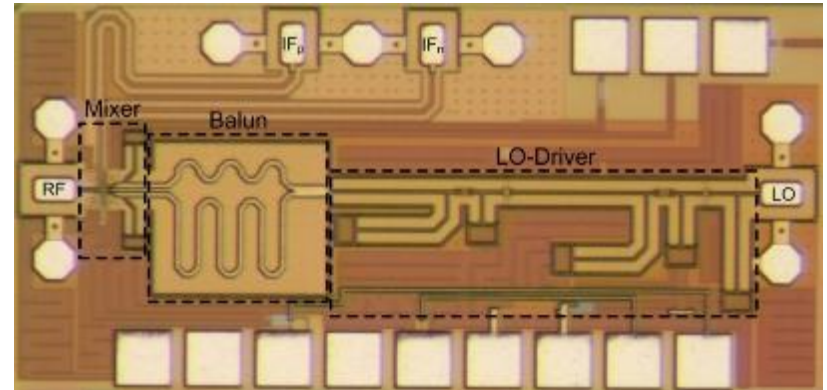
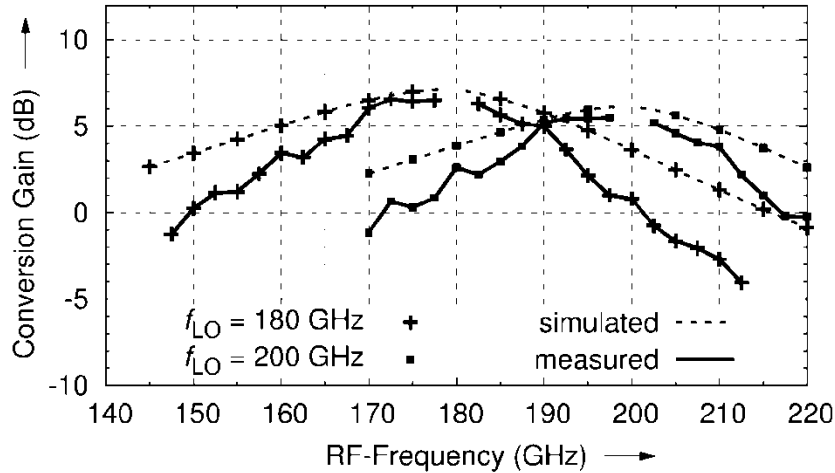

@ $V_{CC,1} = 2.5$ V, $I_{CC,1} = 3+9$ mA,
 $V_{CC,2} = 3.3$ V, $I_{CC,2} = 3$ mA

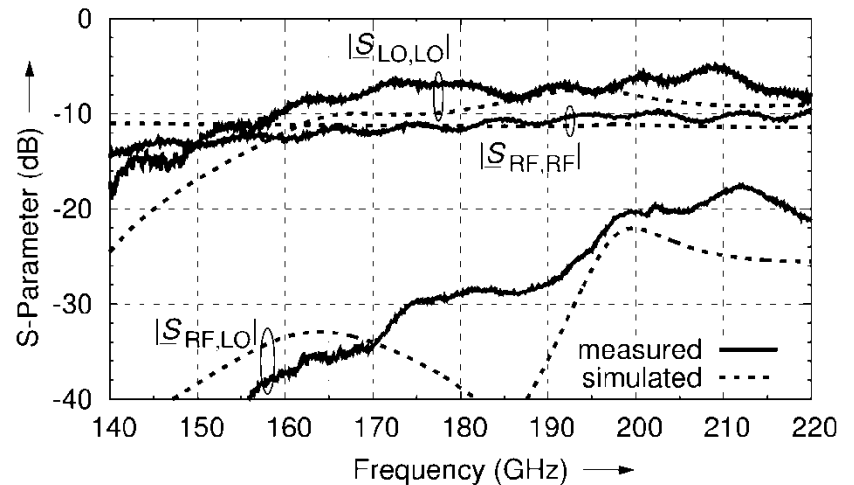
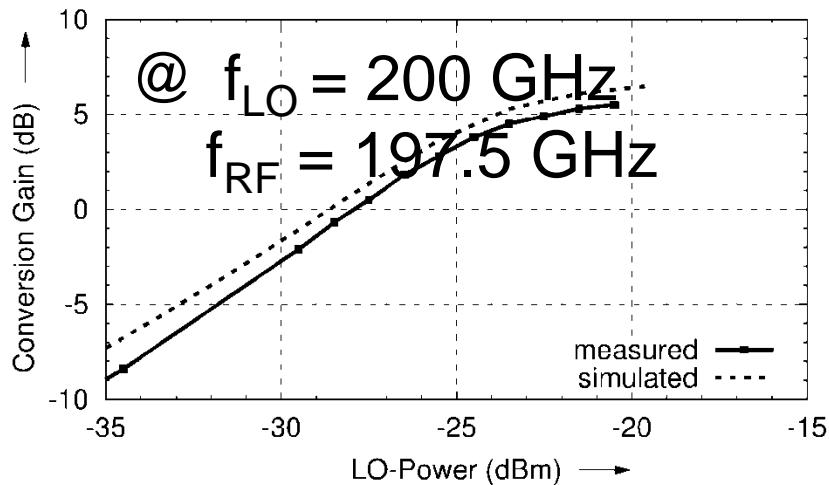

200 GHz – Vector Modulator

- Core component of the beamforming system
- Manufacture in IHP BiCMOS 0.13u SiGe technology and measured
- Two versions: standard VM (left), triple VM (right)
- The largest frequency range compared to the state of the art
- Low-power

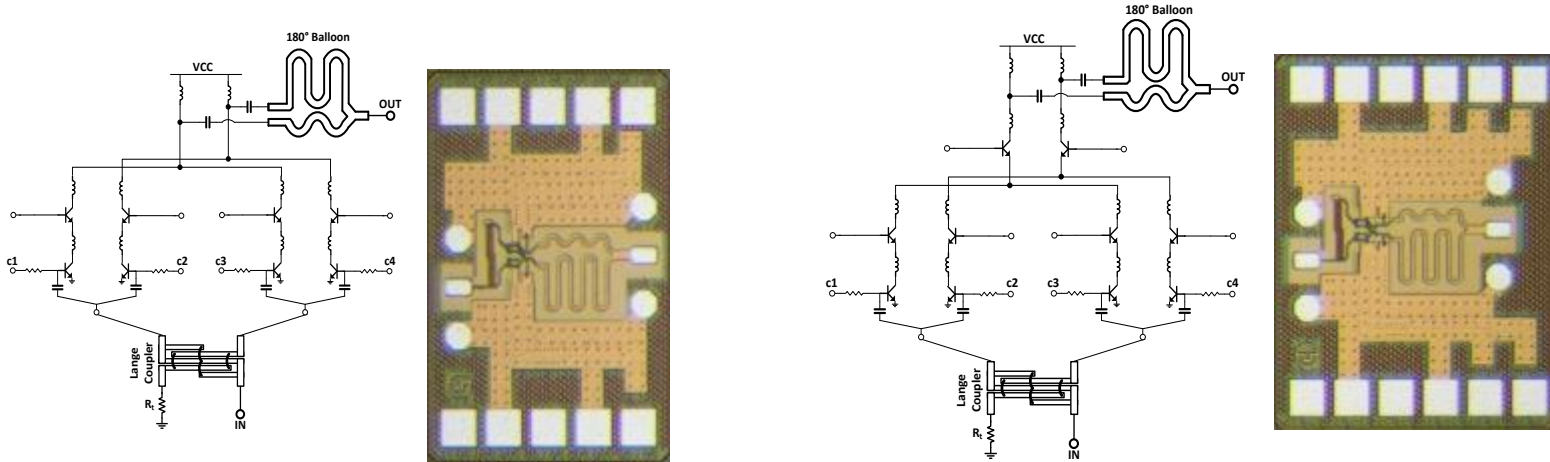

30 GHz PLL

Reference	Technology	PLL lock range (GHz)	FTR (%)	PN at 1 MHz (dBc/Hz)	Reference Spurs (dBc)	Power (mW)
[1]	90 nm CMOS	39.1-41.6	6.2	-90	-54	64
[2]	90 nm CMOS	30-32	6.5	-72	-23	26
[3]	180 nm CMOS	27.8-30.8	10.3	-93.5	-56	112
[4]	250 nm CMOS	28.5-32	11.6	-81	-42	287
[5]	180 nm BiCMOS	29.5-33.4	12.4	-97	-40	63
fast-spot PLL	130 nm BiCMOS	28.7-33.7	16	-100 to -97	-63*	530

* at $f_0/4$

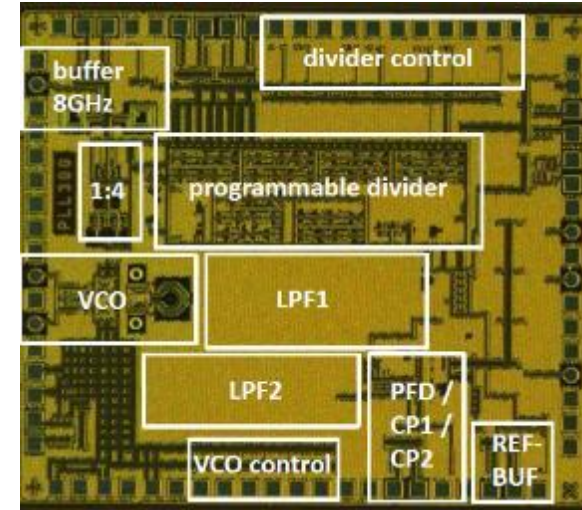

[1] S. Pellerano, R. Mukhopadhyay, A. Ravi, J. Laskar, and Y. Palaskas, "A 39.1-to-41.6 GHz fractional-N frequency synthesizer in 90 nm CMOS," ISSCC Digest of Technical Papers, San Francisco, USA, pp. 484-485, Feb. 2008.

[2] C. Marcu et al., "A 90 nm CMOS low-power 60 GHz transceiver with integrated baseband circuitry," IEEE J. Solid-State Circuits, vol. 44, no. 12, pp. 3434-3447, Dec. 2009.

[3] P.-S. Weng and L.-H. Lu, "A 30 GHz CMOS frequency synthesizer for V-band applications," IEEE Microwave and Wireless Components Letters, vol. 22, no. 8, pp. 433-435, Aug. 2012.

[4] J.-Y. Lee, S.-H. Lee, H. Kim, and H. Yu, "A 28.5-32-GHz fast settling multichannel PLL synthesizer for 60-GHz WPAN radio," IEEE Trans. Microw. Theory Tech., vol. 56, no. 5, pp. 1234-1246, May 2008.

[5] J. Mahalingam, Y. Wang, B. K. Thangarasu, K. Ma, K. S. Yeo, and Y. S. Tan, "A multi-mode 30 GHz 2 degree RMS power efficient phase-locked loop frequency synthesizer," in Proc. of the IEEE MTT-S International Microwave Symposium, San Francisco, USA, pp. 1-4, May 2016.

190 GHz Integrated Receiver

$P_{LO} = -17\text{dBm}$
 $P_{DC} = 122\text{mW}$
 $\text{OP}_{1\text{dB}} \approx 0\text{dBm}$

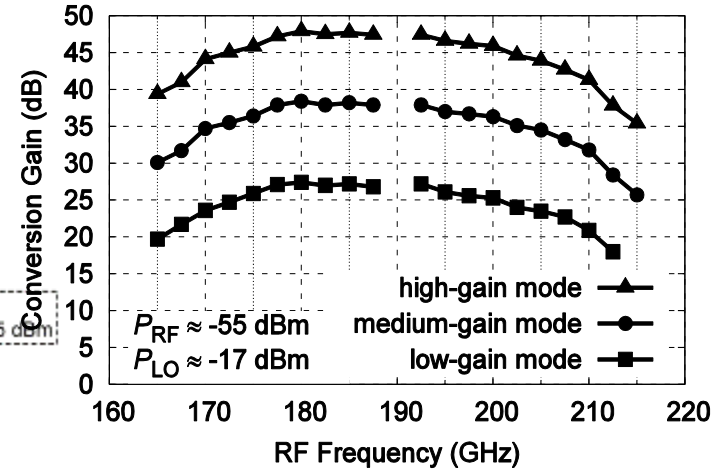
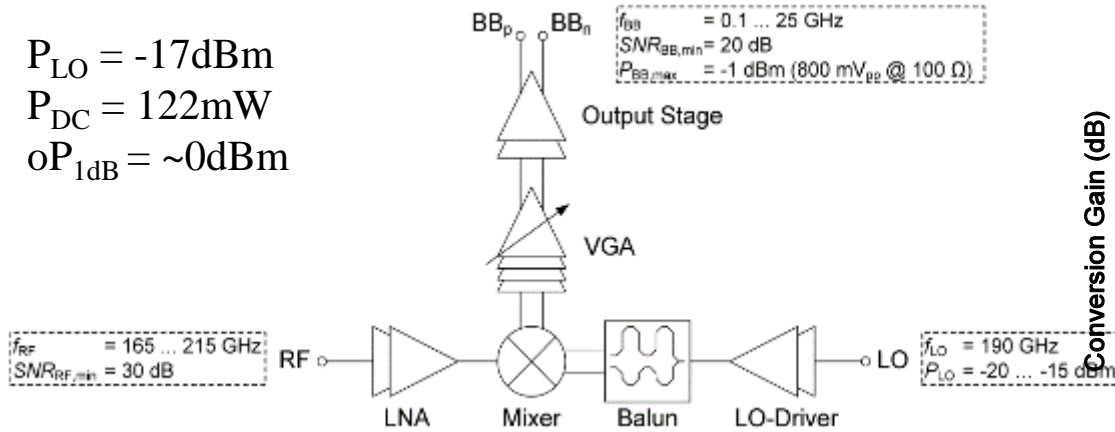

$1820 \times 680 \mu\text{m}^2$

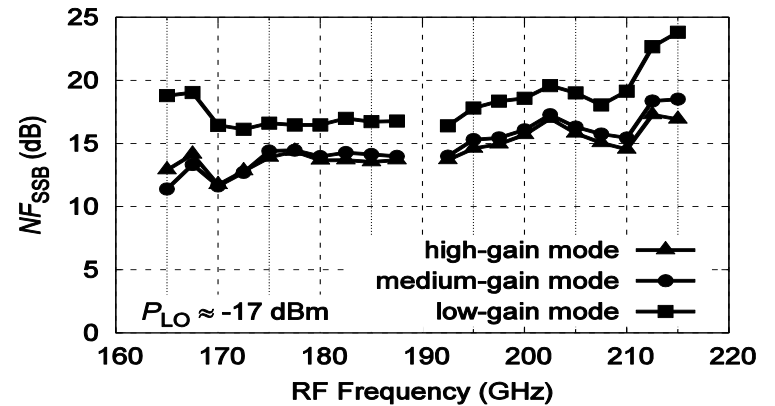
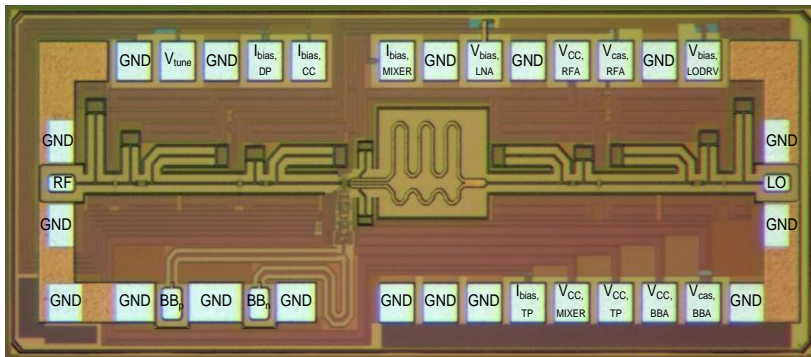

Phased-Array Receiver Frontend

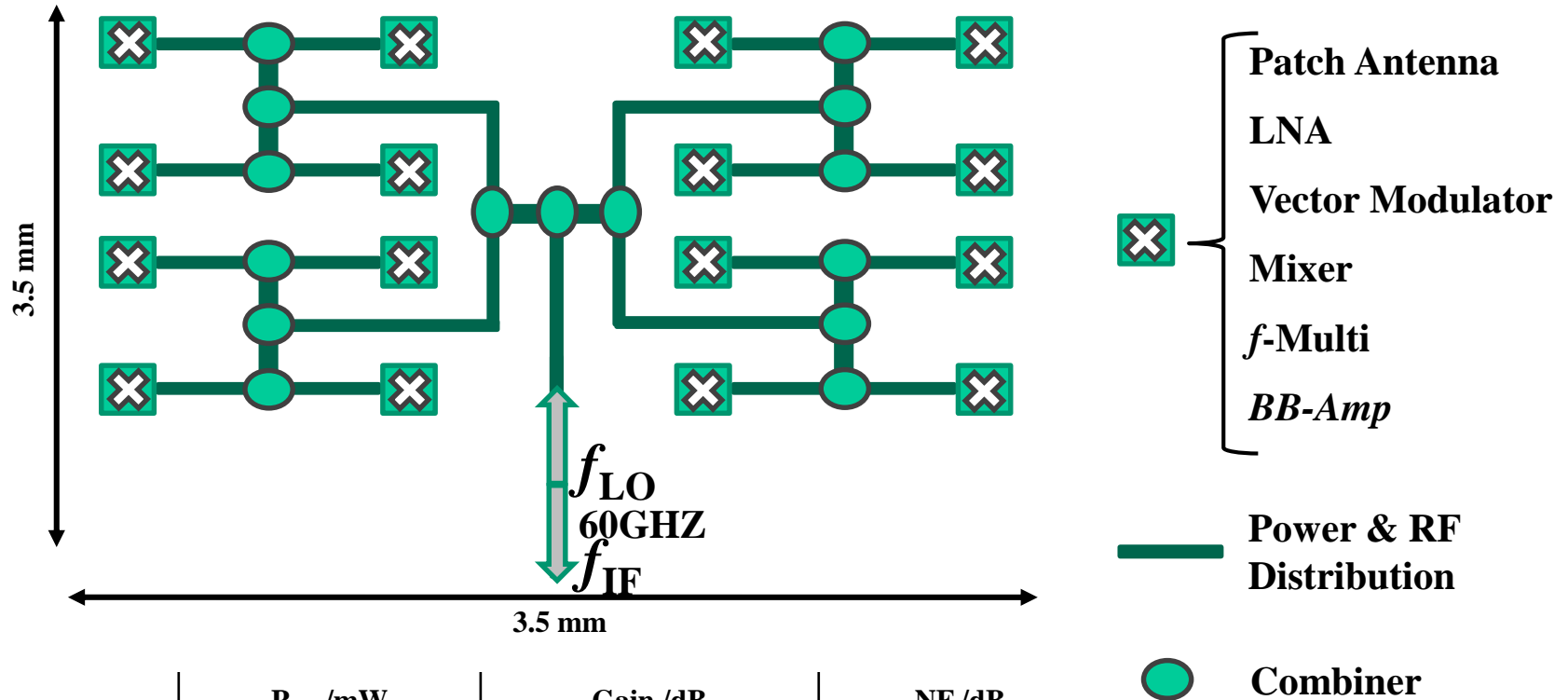

	P_{DC} /mW	Gain /dB	NF /dB
<i>Passive Combiner</i>	2400	17 (LNA)+ 12 (VM) + (6) Mixer + (17) BB-AMP = 52	10.5 + Mixer and f-Multi

Demonstration of the Full 200 GHz System

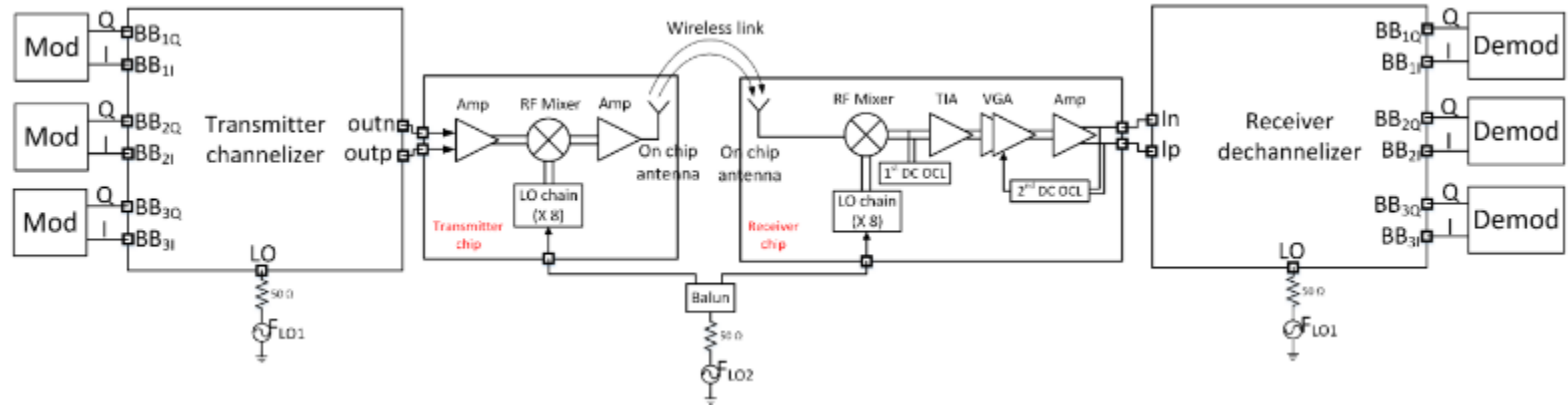

Net data throughput per channel when measuring the 3-channel frequency multiplexer

Modulation	OTA data rates	Code rate r	Net data rates
BPSK	1296 Mbps	1/2	648 Mbps
		2/3	864 Mbps
QPSK	2592 Mbps	1/2	1296 Mbps
		2/3	1728 Mbps
16QAM	5184 Mbps	1/2	2592 Mbps
		2/3	3456 Mbps
		3/4	3888 Mbps

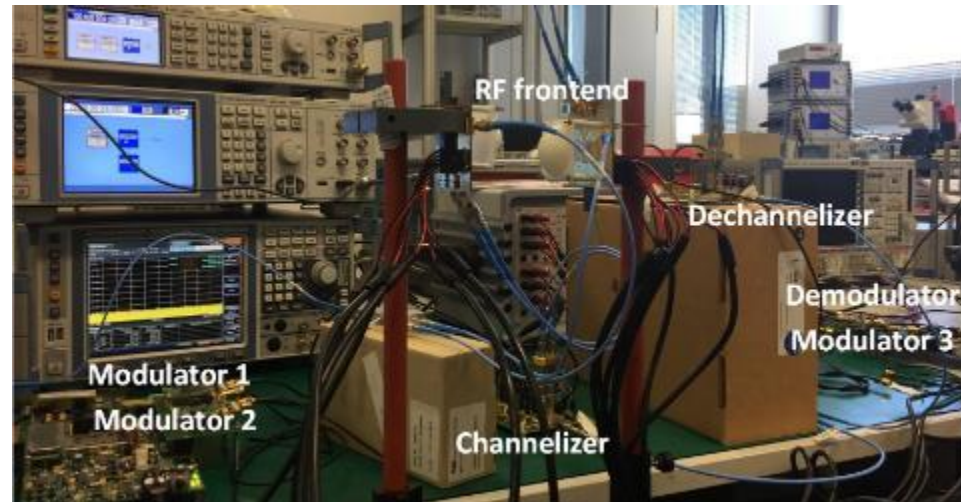

Newest Developments in fastSpot

4x4 200 GHz AFE incl. Beamforming (IHP SG13G2)

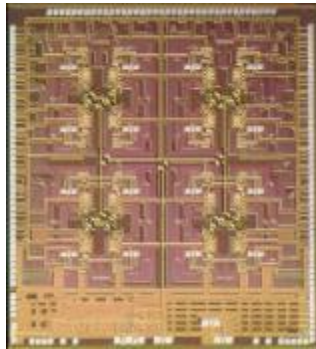

Transmitter

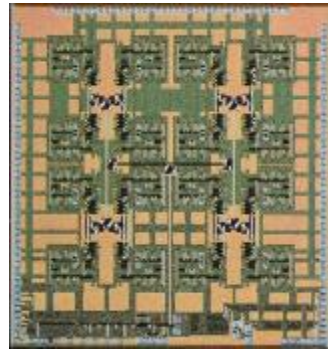

Receiver

4x4 Antenna Array (IHP SG13BEOL + LBE)



5-Chanel IF Multiplexer/Demultiplexer up 20 GHz BB Bandwidth (IHP SG13G2)

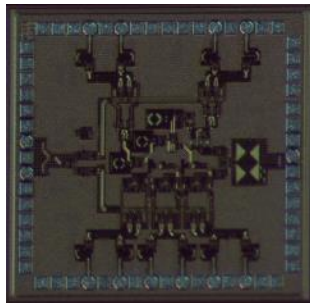

Transmitter

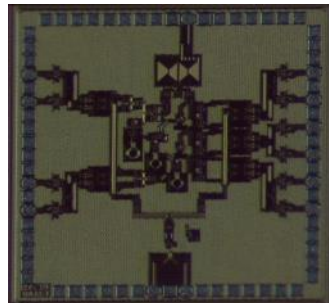

Receiver

64-channel DAC board for vector modulation control



Conclusions

- **Development of an 200 GHz Channel Sounder**
 - Dual polarized capability at TX (switched) and RX (parallel)
 - Multi-Band measurements allow the direct comparison of propagation effects from millimetre waves to terahertz
 - Integration of a wave guide PAs with 5 dBm outpower
 - RT parameterization for many bands (3-10, 27-36, 60-67, 71-78, 180-220 GHz)
- **Development of an 200 GHz Demonstrator**
 - Development of fully integrated 200 GHz RF Transmitter and Receiver MMIC
 - System includes a 4x4 phase array antenna with a max. output power of 5 dBm per port
 - High precise PLL are include to provide a low phase noise at 200 GHz