

Project: IEEE P802.15 Working Group for Wireless Personal Area Networks (WPANs)

Submission Title: THz Communications – An Overview and Options for IEEE 802 Standardization

Date Submitted: 11 November 2018

Source: Thomas Kürner (Editor) **Company:** TU Braunschweig, Institut für Nachrichtentechnik

Address: Schleinitzstr. 22, D-38092 Braunschweig, Germany

Voice: +495313912416

FAX: +495313915192, E-Mail: t.kuerner@tu-bs.de

Re: n/a

Abstract: Over the last couple of years in particular, THz communications, i. e. the frequency range beyond 275 GHz, has become an attractive new research area for commercial development. It has reached a level of maturity that a couple of projects are now underway to develop technological solutions enabling the set-up of hardware demonstrators. This tutorial will provide a brief overview on the current status of THz Communication systems focusing on ongoing research activities such as the European Horizon 2020 framework, and provide an overview of the ongoing WRC 2019 preparations, as well as discussing the potential for IEEE 802 to play a major role in this interesting frequency range.

Purpose: Tutorial on the activities and the status of the IEEE 802.15 TAG THz presented to the IEEE 802 Plenary

Notice: This document has been prepared to assist the IEEE P802.15. It is offered as a basis for discussion and is not binding on the contributing individual(s) or organization(s). The material in this document is subject to change in form and content after further study. The contributor(s) reserve(s) the right to add, amend or withdraw material contained herein.

Release: The contributor acknowledges and accepts that this contribution becomes the property of IEEE and may be made publicly available by P802.15.

THz Communications – An Overview and Options for IEEE 802 Standardization

Tutorial at IEEE 802 Plenary, November 2018
by IEEE 802.15 TAG THz

Presenters:

Thomas Kürner, TU Braunschweig, Germany

Akifumi Kasamatsu, NICT, Japan

Onur Sahin, InterDigital, UK

Carlos Castro, Fraunhofer Heinrich Hertz Institute, Germany

Outline

- Status on THz Communication in Standardisation, Regulation and Research (Thomas Kürner)
- Silicon CMOS Transceiver for Terahertz Wireless Communication (Akifumi Kasamatsu)
- Towards Ultra-High Throughput FEC Design: EPIC Project (Onur Sahin)
- Integration of fiber-optics/THz Technologies (Carlos Castro)
- Conclusion and Outlook (Thomas Kürner)

Status on THz Communication in Standardisation, Regulation and Research

Thomas Kürner, Sebastian Rey, Johannes Eckhardt

Technische Universität Braunschweig, Germany

Motivation for THz Communications

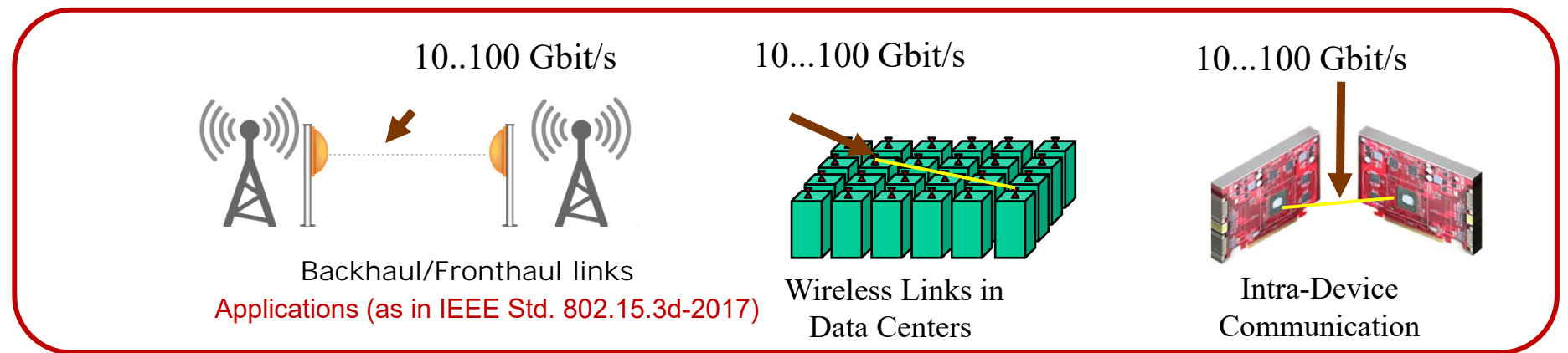
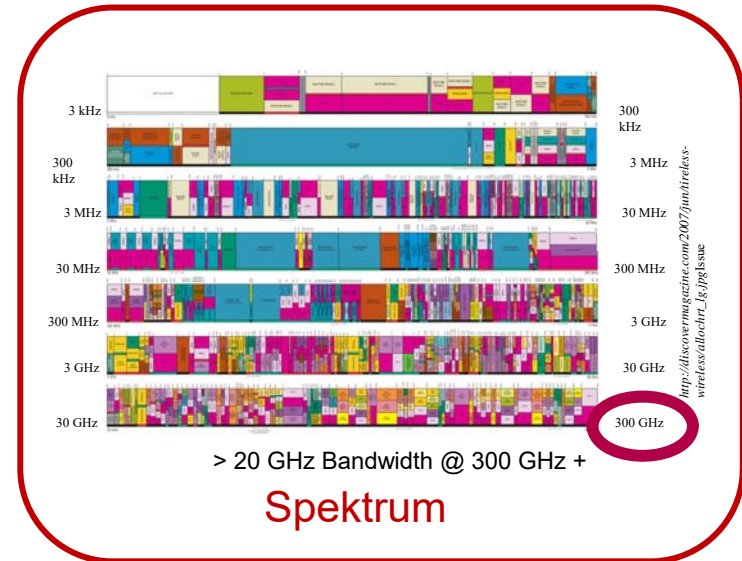
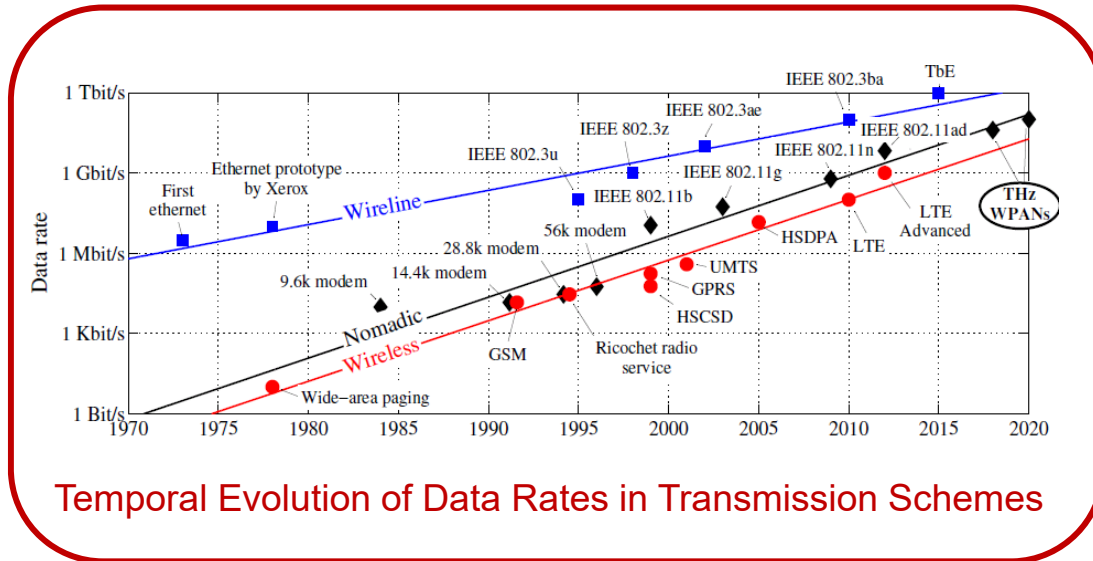

STATUS IN STANDARDISATION

IEEE Std. 802.15.3d-2017

Key Facts

- New PHY for Std. IEEE 802.15.3-2016
- MAC is mainly based on IEEE 802.15.3e-2017, which introduced the concept of „Pairnet“
 - Point-to-point nature with highly-directive antennas reduces the problem of interference and „fighting for access“
 - Positions of Tx and Rx antennas are known
- 8 different channel bandwidths (as multiples of 2.16 GHz)
- 2 PHY-modes (THz-SC PHY, THz-OOK-PHY) with 7 modulation schemes:
 - BPSK, QPSK, 8-PSK, 8-APSK, 16-QAM, 64 QAM, OOK
- 3 channel coding schemes:
 - 14/15-rate LDPC (1440,1344), 11/14-rate LDPC (1440,1056), 11/14-rate RS(240,224)-code.

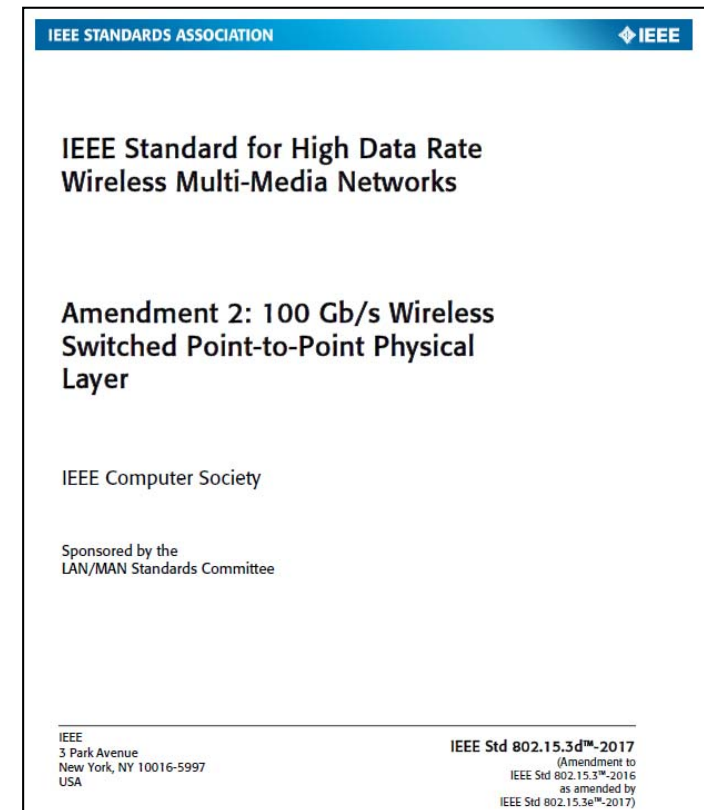

Channel plan

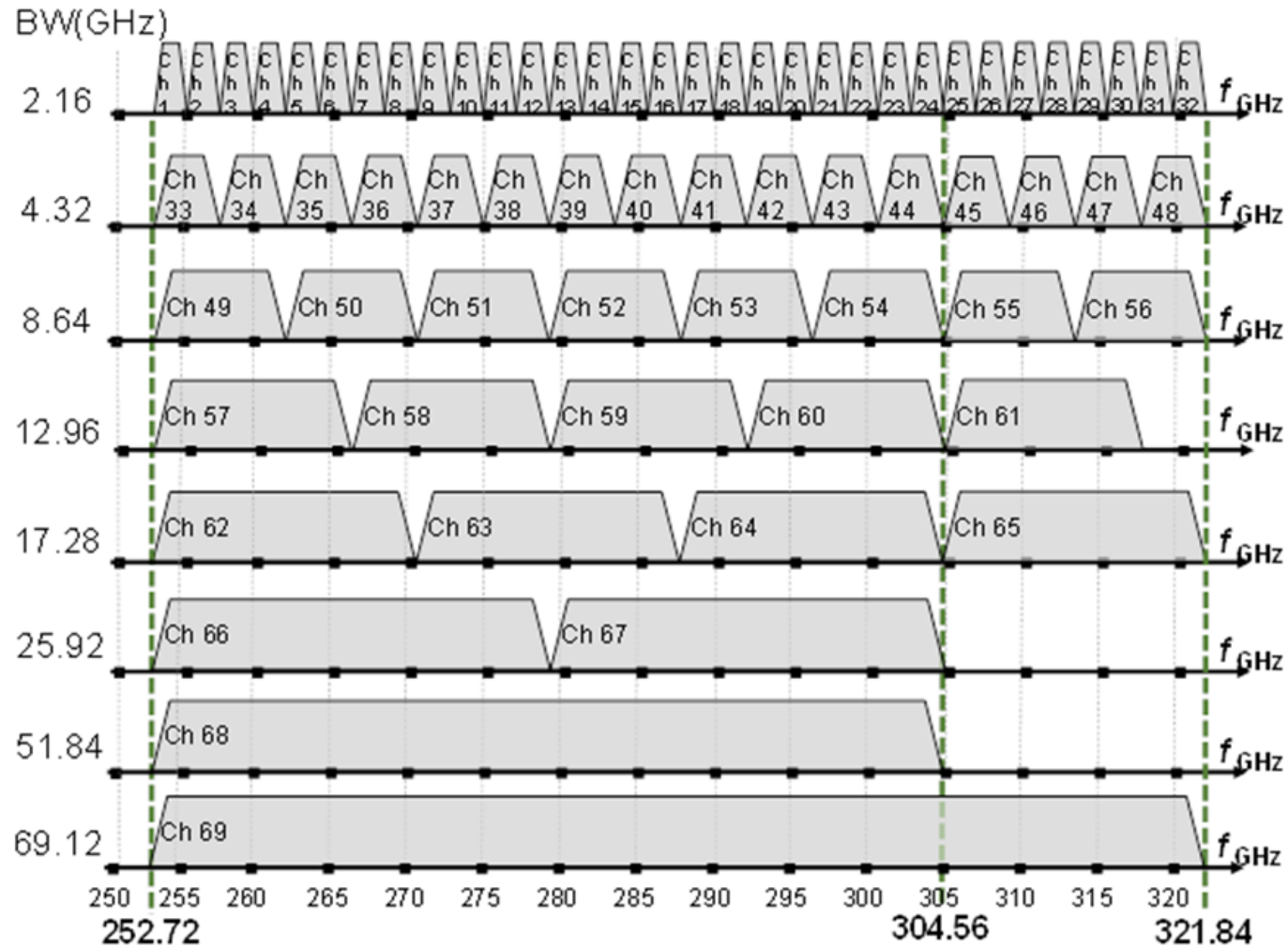

Exemplary Simulation Results for Backhaul/Fronthaul Applications

- Assumption of a margin of 20 dB for atmospheric attenuation

MCS Identifier	Modulation	FEC Rate	Maximum Link Distance in m							
			2.16 GHz	4.32 GHz	8.64 GHz	12.96 GHz	17.28 GHz	25.92 GHz	51.84 GHz	69.12 GHz
0	BPSK	11/15	5343	3778	2671	2181	1889	1542	1091	944
1	BPSK	14/15	3646	2578	1823	1488	1289	1052	744	644
2	QPSK	11/15	3796	2684	1898	1550	1342	1096	775	671
3	QPSK	14/15	2563	1812	1282	1046	906	740	523	453
4	8-PSK	11/15	2157	1525	1078	880	762	623	440	381
5	8-PSK	14/15	1725	1220	862	704	610	498	352	305
6	8-APSK	11/15	2157	1525	1078	880	762	623	440	381
7	8-APSK	14/15	1729	1223	864	706	611	499	353	306
8	16-QAM	11/15	1709	1209	855	698	604	493	349	302
9	16-QAM	14/15	1152	814	576	470	407	332	235	204
10	64-QAM	11/15	949	671	475	387	336	274	194	168
11	64-QAM	14/15	581	411	291	237	205	168	119	103

Data rate > 50 Gbit/s

Data rate > 100 Gbit/s

Source: doc. IEEE 802.15-17-0039-04-003d

STATUS IN REGULATION

Starting point for Radio Regulations: Outcome of WRC 2012

- **5.565** A number of bands in the frequency range 275-1 000 GHz are identified for use by administrations for passive service applications. The following specific frequency bands are identified for measurements by passive services:
 - – radio astronomy service: 275-323 GHz, 327-371 GHz, 388-424 GHz, 426-442 GHz, 453-510 GHz, 623-711 GHz, 795-909 GHz and 926-945 GHz;
 - – Earth exploration-satellite service (passive) and space research service (passive): 275-286 GHz, 296-306 GHz, 313-356 GHz, 361-365 GHz, 369-392 GHz, 397-399 GHz, 409-411 GHz, 416-434 GHz, 439-467 GHz, 477-502 GHz, 523-527 GHz, 538-581 GHz, 611-630 GHz, 634-654 GHz, 657-692 GHz, 713-718 GHz, 729-733 GHz, 750-754 GHz, 771-776 GHz, 823-846 GHz, 850-854 GHz, 857-862 GHz, 866-882 GHz, 905-928 GHz, 951-956 GHz, 968-973 GHz and 985-990 GHz.
- The use of the range 275-1 000 GHz by the passive services does not preclude use of this range by active services.
- Administrations wishing to make frequencies in the 275-1 000 GHz range available for active service applications are urged to take all practicable steps to protect these passive services from harmful interference until the date when the Table of Frequency Allocations is established in the above-mentioned 275-1 000 GHz frequency range.
- All frequencies in the range 1 000-3 000 GHz may be used by both active and passive services. (WRC-12)

Possible Interference Scenarios to be studied

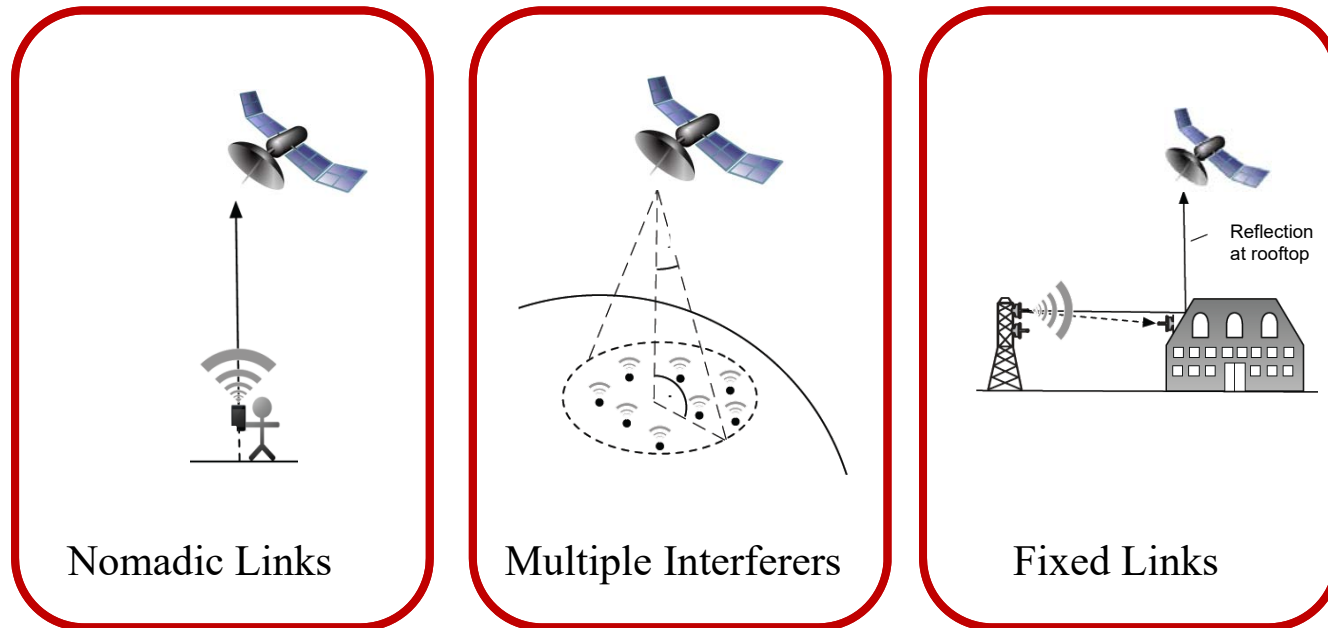

S. Priebe et al. „Interference Investigations of Active Communications and Passive Earth Exploration Services in the THz Frequency Range“, IEEE Transactions on THz Science and Technology, vol. 2, no. 5, pp. 525-537, 2012

Current status of the preparatory work of AI 1.15 @ WRC 2019

- WRC 2015 agreed in resolution 767:
 - to have an agenda item for WRC 2019 to consider **identification of spectrum for land-mobile and fixed active services in the range of 275 GHz to 450 GHz** while maintaining protection of the passive services identified in the existing footnote 5.565.

Current Status

- Regarding the new active services the reports ITU-R F.2416 and ITU-R M.2417 have been published.
- The frequency bands of interest are
 - between 275 to 450 GHz for land mobile applications.
 - especially, 275-325 GHz and 380-445 GHz for fixed service applications
- ITU-R WP 1A is conducting sharing studies and preliminary results are available.
 - **For instances in the band 275 to 296 GHz** coexistence with the passive services seems to be possible. This provides a **continues bandwidth of 44 GHz** with the existing band from 252-275 GHz.
 - Other bands are under consideration.

RECENT ACTIVITIES IN THE EU-RESEARCH PROGRAM HORIZON 2020

H2020-ICT-09-2017-Cluster on Networks Beyond 5G

- Seven funded projects from the H2020 calls ICT-09-2017 and EUJ-02-2018 form an informal cluster:
 - DREAM: D-band Radio solution Enabling up to 100 Gb/s reconfigurable Approach for Meshed beyond 5G network
 - EPIC: Enabling Practical Wireless Tb/s Communications with Next Generation Channel Coding
 - TERAPOD: Terahertz based Ultra High Bandwidth Wireless Access Networks
 - TERRANOVA: Terabit/s Wireless Connectivity by Terahertz Innovative Technologies to deliver Optical Network Quality of Experience in Systems Beyond 5G
 - ULTRAWAVE: Ultra capacity wireless layer beyond 100 GHz based on millimeter wave Traveling Wave Tubes
 - WORTECS: Wireless Optical/Radio Terabit Communications
 - ThoR: TeraHertz end-to-end wireless systems supporting ultra high data Rate applications



Horizon 2020 Project TERAPOD

- Project Duration: September 2017 – August 2020
- Project Goals:
 - to investigate and demonstrate the feasibility of ultra high bandwidth wireless access networks operating in the Terahertz band.
 - The project will focus on end to end *demonstration of the THz wireless link within a Data Centre Proof of Concept deployment*, while also investigating other use cases applicable to beyond 5G
 - The project seeks to bring THz communication a leap closer to industry uptake through leveraging recent advances in THz components, a thorough measurement and characterization study of components and devices, coupled with specification and validation of higher layer communication protocol specification.
- The TERAPOD project has received funding from the European Union's Horizon 2020 research and innovation programme under grant agreement No 761579
- Web Page: www.terapod-project.eu



Some first Results from TERAPOD

- 300 GHz channel measurements in the Research Data Center of Dell/EMC using the time-domain channel sounder (approx. 8 GHz of bandwidth) available at TU Braunschweig

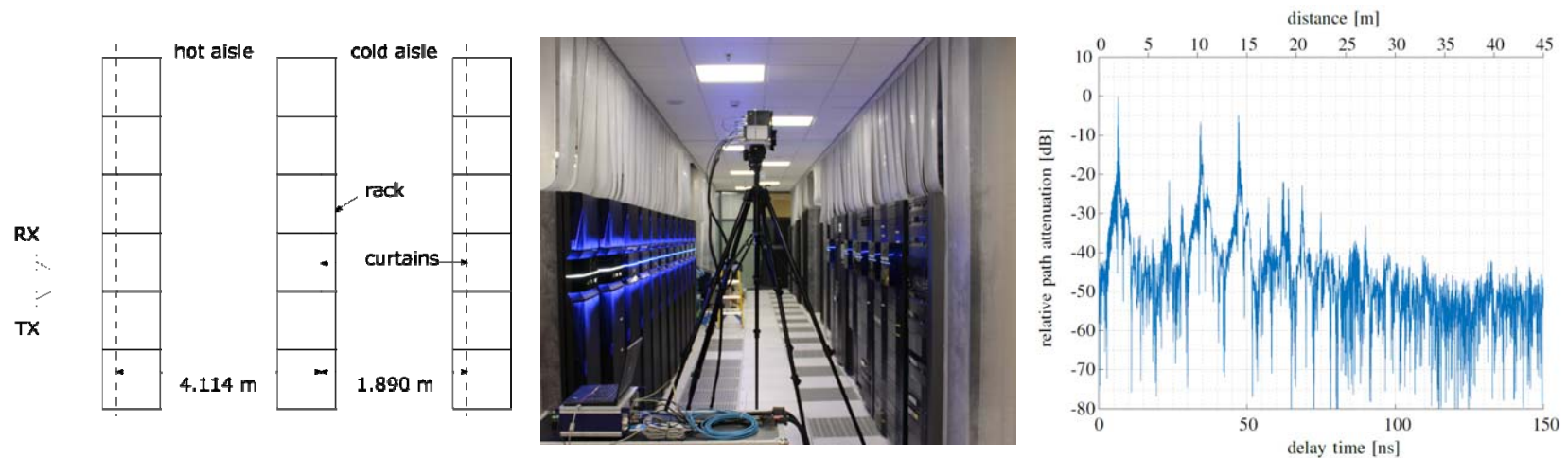

For more information see doc. IEEE 802.15-18-0519-00-0thz

Horizon 2020 EU-Japan Project ThoR on THz Backhaul/Fronthaul Links



- Project duration 1.7.2018-30.6.2020
- ThoR is equally funded from
 - Horizon 2020, the European Union's Framework Programme for Research and Innovation, under grant agreement No. 814523 and
 - the National Institute of Information and Communications Technology in Japan (NICT)

Web page: www.thor-project.eu

Participants	Country
Companies	
Deutsche Telekom AG	Germany
NEC Corporation	Japan
Siklu Communication Ltd.	Israel
Vivid Components Ltd.	UK
HRCP	Japan
R&D	
Fraunhofer IAF	Germany
University of Lille / IEMN Laboratory	France
Universities	
TU Braunschweig (Coordinator, EU)	Germany
Chiba Institute of Technology	Japan
Gifu University	Japan
University of Stuttgart	Germany
Waseda University (Coord., Japan)	Japan

ThoR Concept towards the Demonstration of a 300 GHz Link for Backhaul/Fronthaul

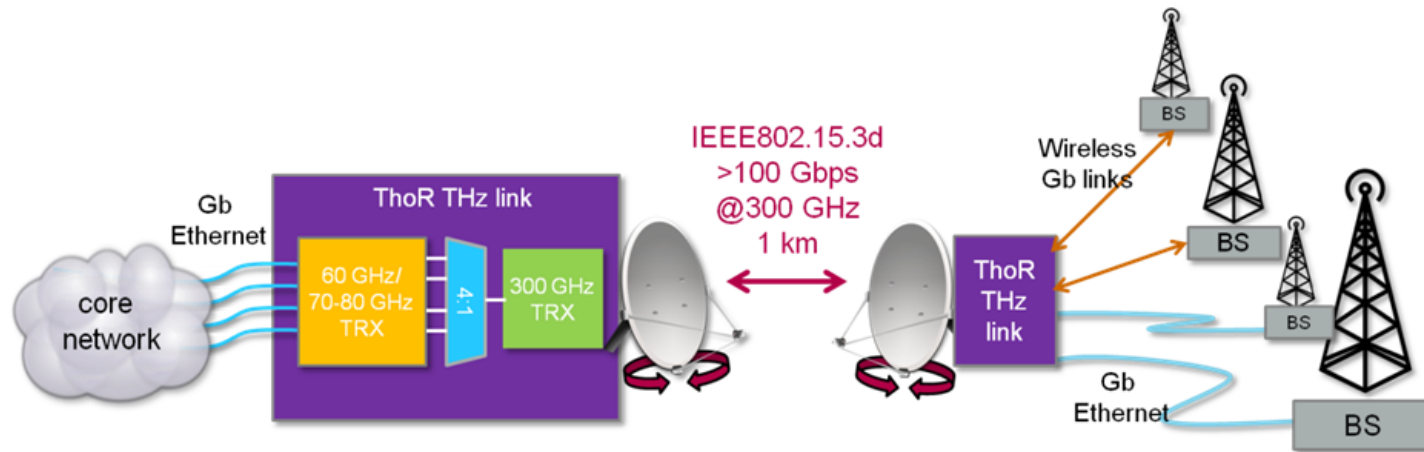

Key Enabling Technologies (KETs)

1. Photonics-based LO
2. Electronic THz amplifier and up-converter
3. High Power THz traveling-wave tube amplifier
4. Electronic THz receiver
5. Digital baseband and networking interface
6. Contributions to spectrum regulation and interference mitigation



Key Performance indicators (KPIs)

1. Transmitter linearity, bandwidth & output power
2. Spectral purity of photonic THz LO
3. Bandwidth, noise & linearity in the receiver
4. Real-time data rate processing capability
5. Spectral efficiency (bit/s/Hz)
6. System capacity (Gbps×km)

For more information see doc. IEEE 802.15-18-0518-00-0thz

In the following presentations ...

...we will provide a more detailed overview on three research activities covering:

- CMOS for THz
- Forward Error Correction for the Tbps age
- Seamless integration of fibre with THz wireless

Silicon CMOS Transceiver for Terahertz Wireless Communication

Akifumi Kasamatsu^{#1}, Shinsuke Hara^{#1}, Kyoya Takano^{#2}, Kosuke
Katayama^{#2}, Ruibing Dong^{#2}, Sangyeop Lee^{#2}, Issei Watanabe^{#1}, Norihiko
Sekine^{#1}, Junji Sato^{#3}, Takeshi Yoshida^{#2}, Shuhei Amakawa^{#2}, Minoru
Fujishima^{#2}

^{#1} National Institute of Information and Communications Technology

^{#2} Hiroshima University

^{#3} Panasonic

Challenge of 300-GHz CMOS transceiver

- PA- and LNA-less architecture because of low f_{\max}
- High data rate with multi-level signals (QPSK, QAMs)

for high speed wireless communication



Developed 300-GHz transceivers

in 40-nm Si CMOS process with $f_{\max} \approx 280\text{GHz}$

in collaboration with Hiroshima Univ., Panasonic, and NICT.

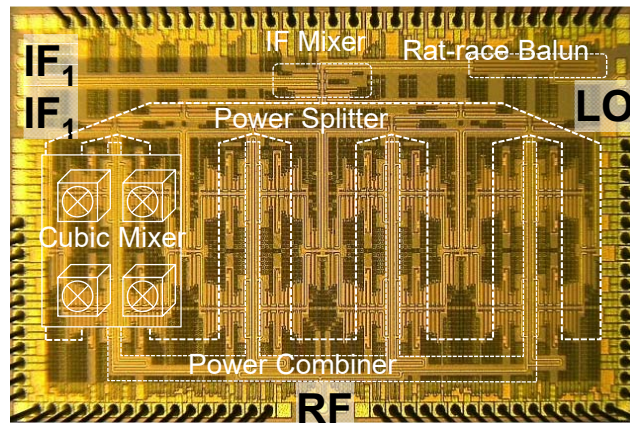

300GHz Si CMOS transmitter^[1]

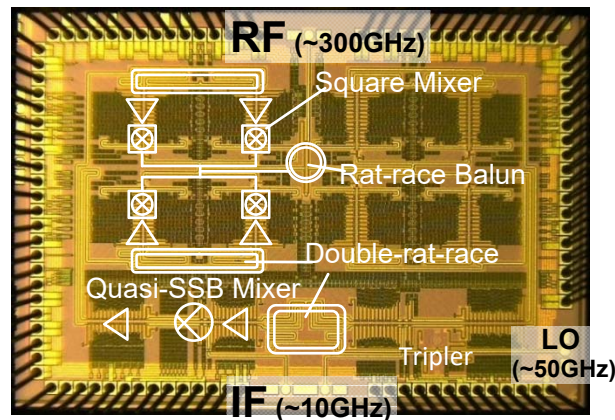

300GHz Si CMOS transmitter^[2]

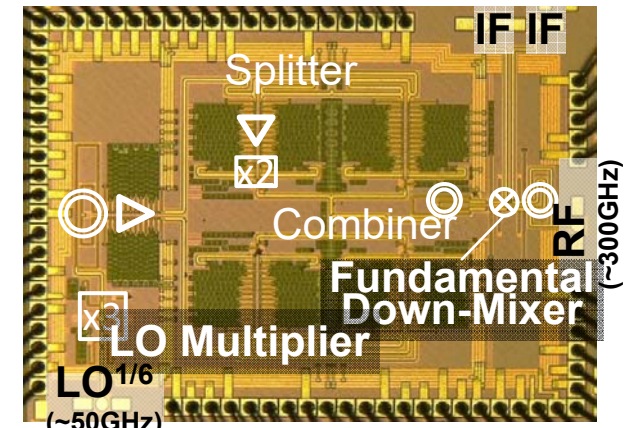

300GHz Si CMOS receiver^[3]

[1] K. Katayama, et al., ISSCC2016, pp. 342–343, Feb. 2016. [2] K. Takano, et al., ISSCC2017, pp. 308–309, Feb. 2017.

[3] S. Hara, et al., IMS2017, pp. 1-4, June 2017.

Key technology for CMOS transmitter

- Gate-pumped Mixer (Square-Mixer)
 - Square-Mixer is essentially a doubler.
 - IF_2 and LO signals are injected into the gate of the FET mixer. Up-converted IF_2 signal using LO is generated. Relatively high output power, good linearity -> **RF signal**
- Image suppression and LO leak cancellation systems

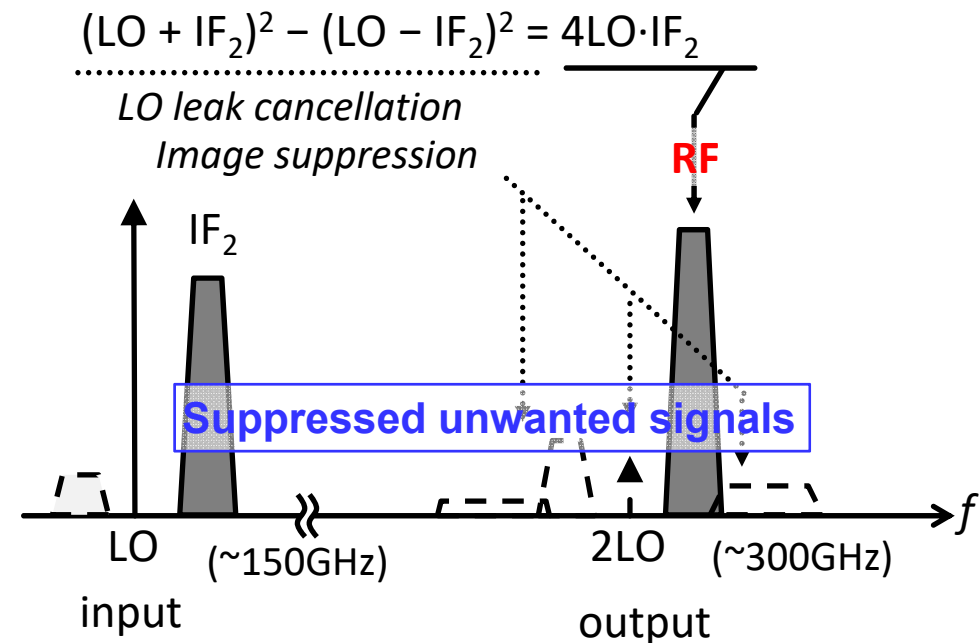
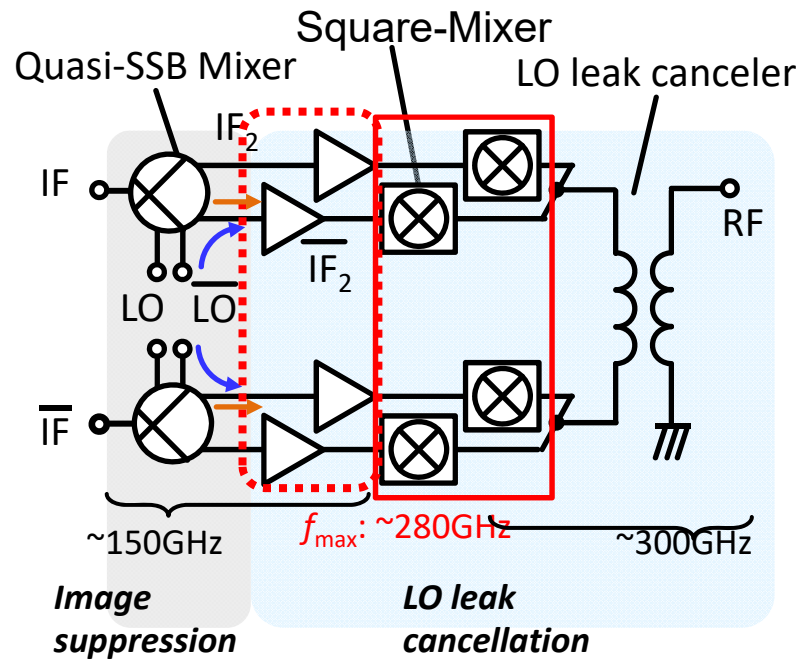

[2] K. Takano, et al., ISSCC2017, pp. 308–309, Feb. 2017.

300-GHz CMOS transmitter

- Schematic, chip micrograph, and measured performance of the 300-GHz CMOS transmitter

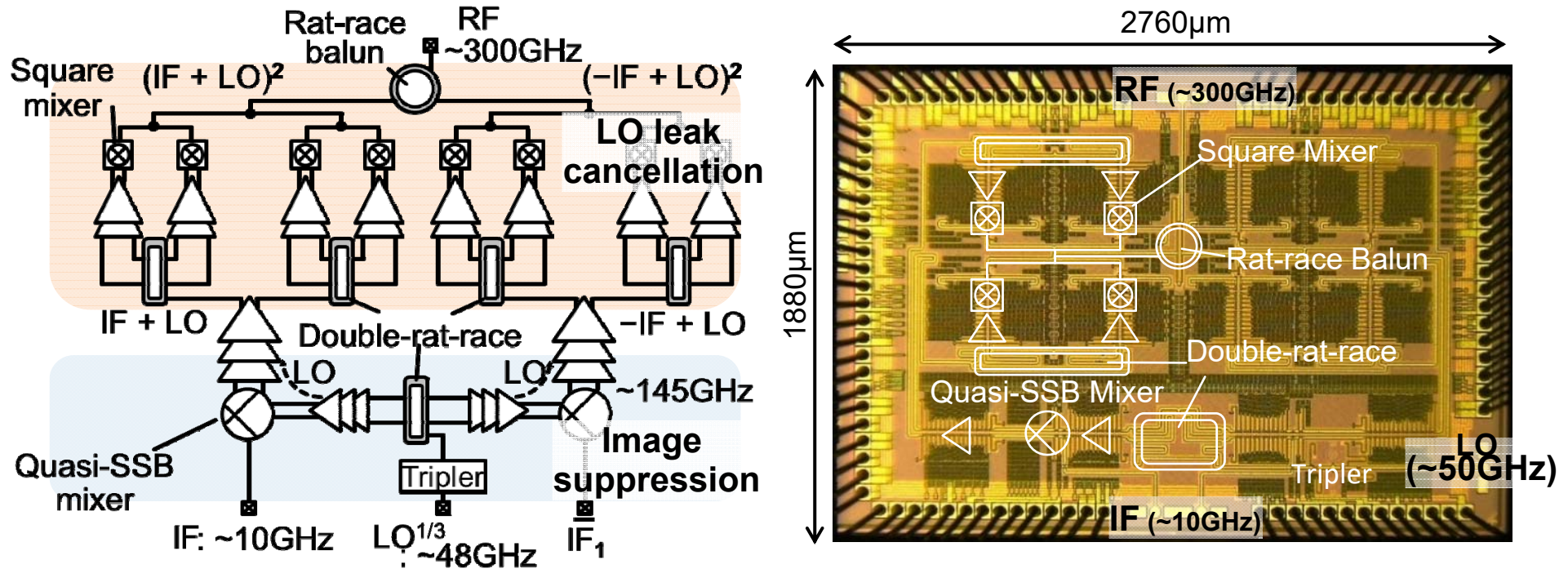

Pout: -5.5 dBm
 RF Freq.: 289 - 311 GHz
 3-dB BW: 22 GHz

[2] K. Takano, et al., ISSCC2017, pp. 308–309, Feb. 2017.

Demonstration of Tx chip

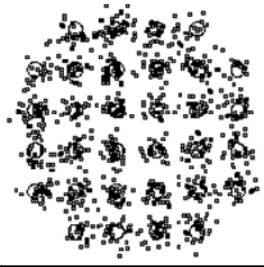
Modulation	32QAM
Constellation (Equalized)	
EVM	8.9%
Data rate	105Gb/s

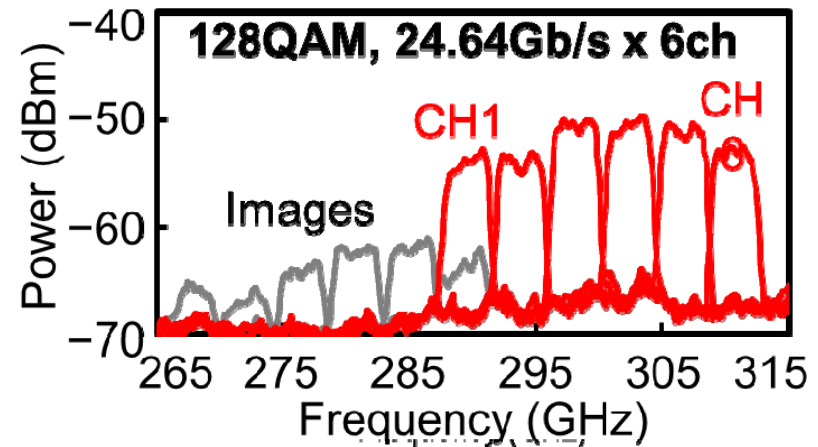
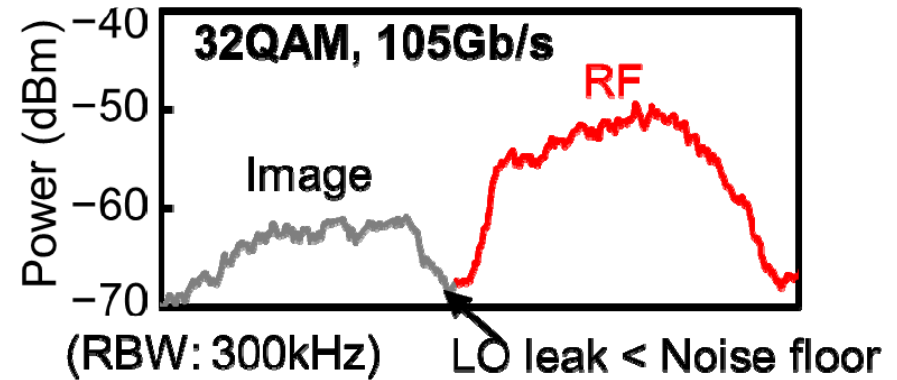

**Achieved a highest data rate of
105 Gbit/s with 32QAM**

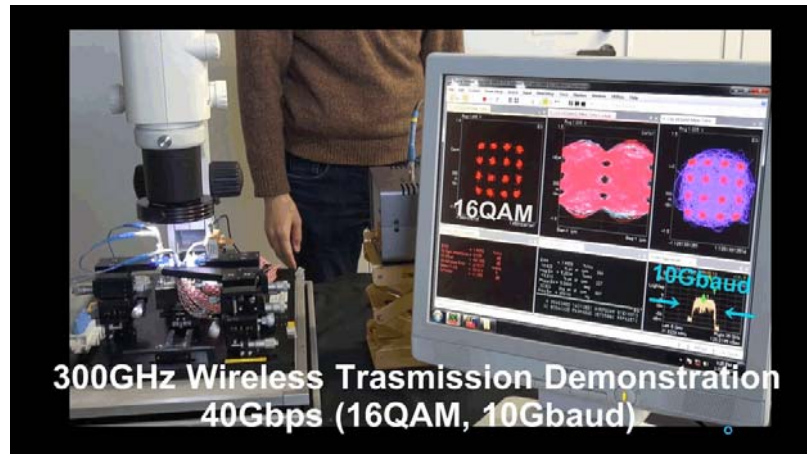

[2] K. Takano, et al., ISSCC2017, pp. 308–309, Feb. 2017.

300-GHz CMOS receiver

- Schematic, chip micrograph, and measured performance of the 300-GHz CMOS receiver

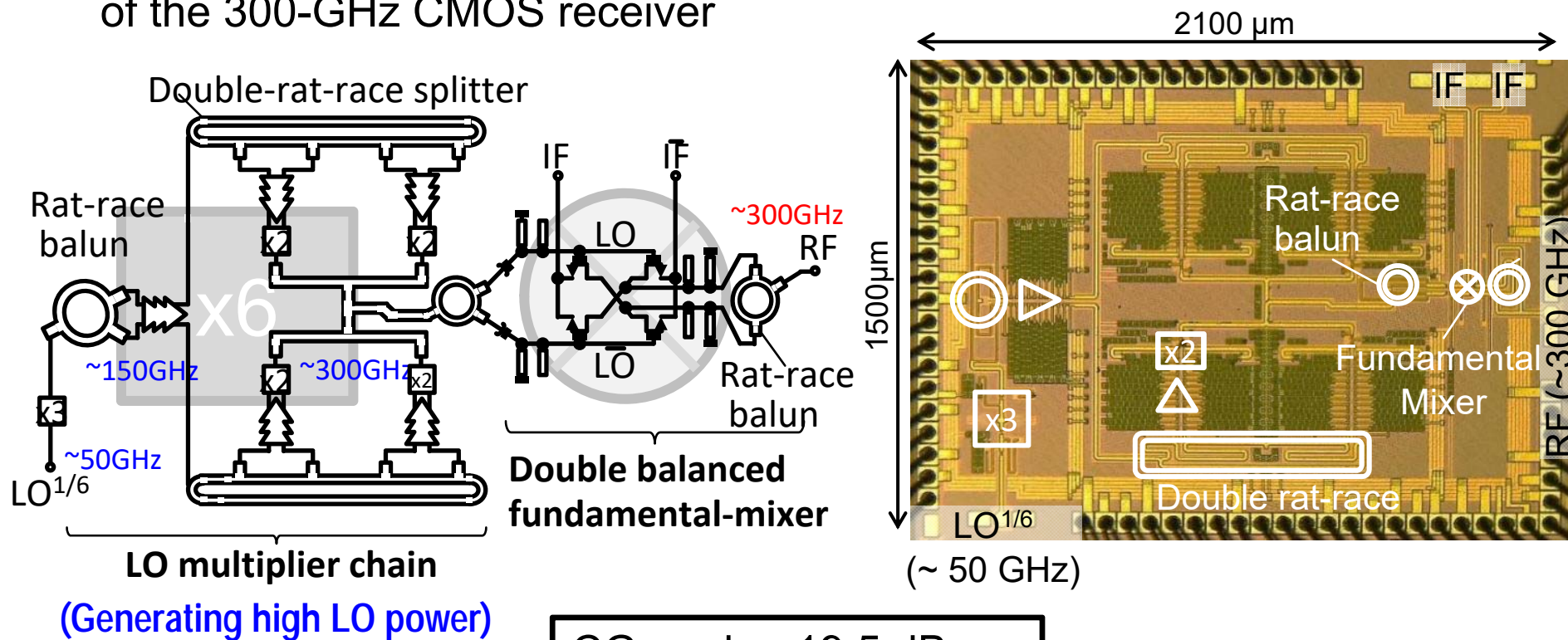

CG peak: -19.5 dB
 Noise figure: 27 dB
 3-dB BW: 26.5 GHz

[3] S. Hara, et al., IMS2017, pp. 1-4, June 2017.

Wireless performance with TX and RX chips

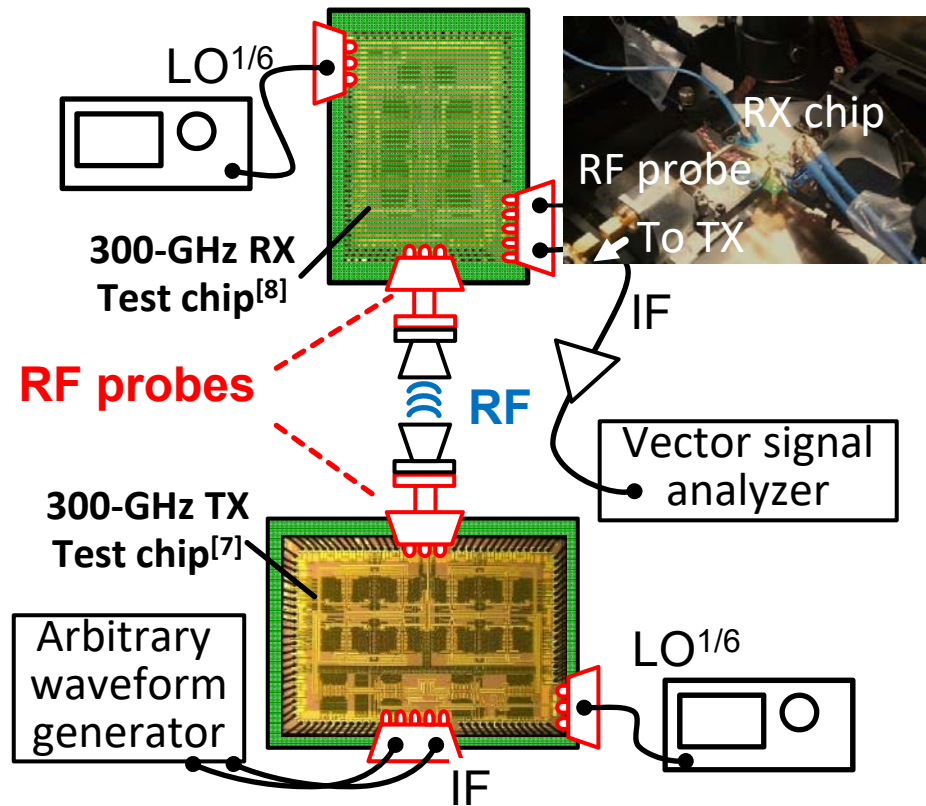

	QPSK	16-QAM
Constellation n (Equalized)		
EVM	19.0%rms	12.2%rms
BER	7.1×10^{-8}	9.3×10^{-5}
Sym. rate	14 Gbaud	8 Gbaud
Data rate	28 Gbit/s	32 Gbit/s

Achieved a wireless data rate of 32 Gbit/s

⇒ For practical use, CMOS TX and RX chip must be packaged and modularized.

[2] K. Takano, et al., ISSCC2017, pp.308-309, Feb. 2017. [3] S. Hara, et al., IMS2017, pp. 1-4, June 2017.

300-GHz CMOS TX and RX modules

- CMOS-chip-to-waveguide transition integrated into a low-cost multilayered glass epoxy PCB

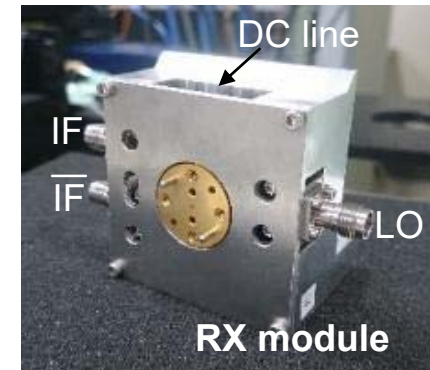
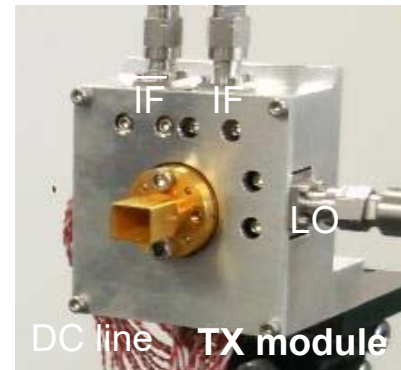
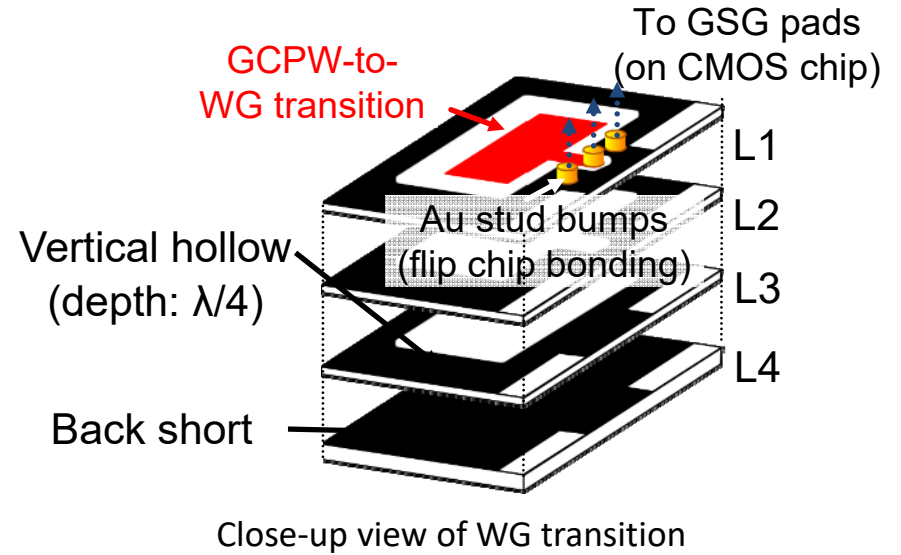
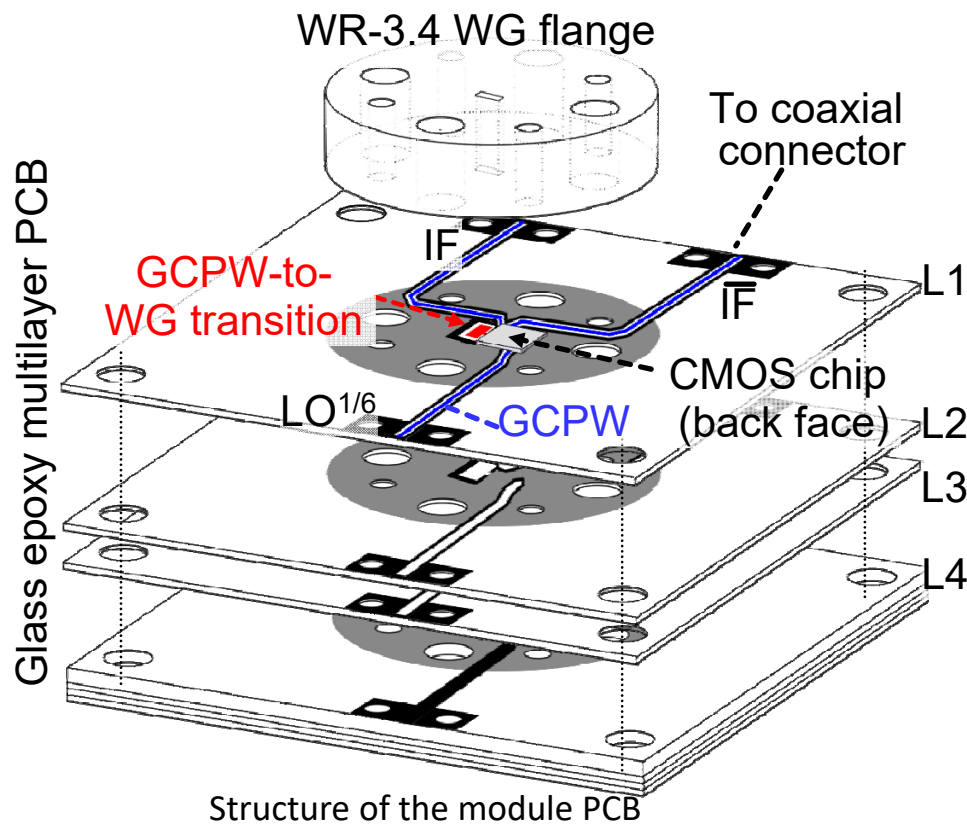

[4] K. Takano, et al., RWS2018, pp. 154–156, Jan. 2018. [5] S. Hara, et al., EuMW2018, Sep. 2018.

Performance of TX module

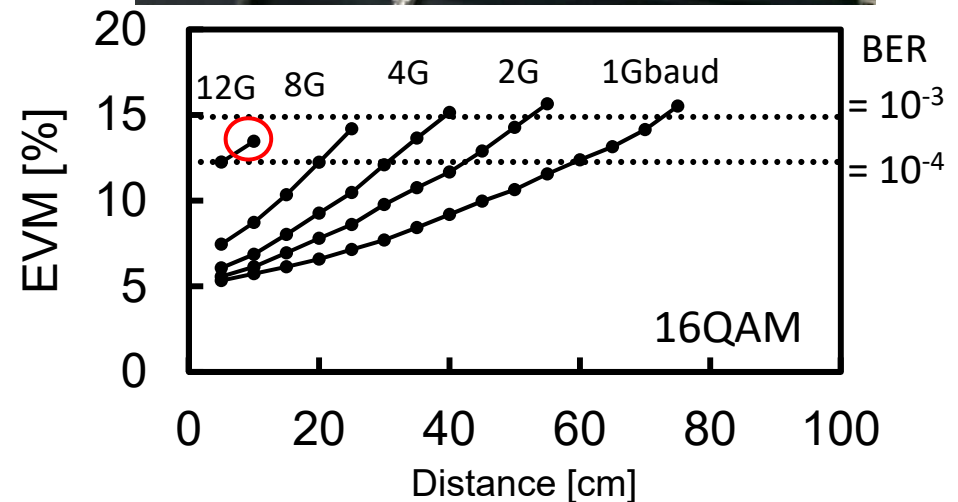
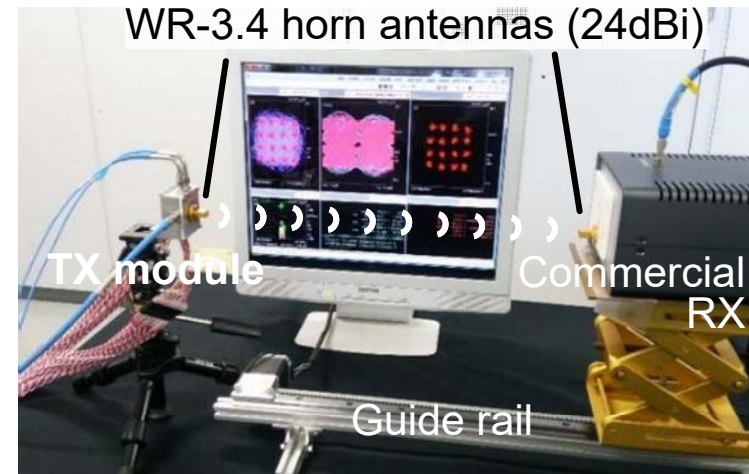
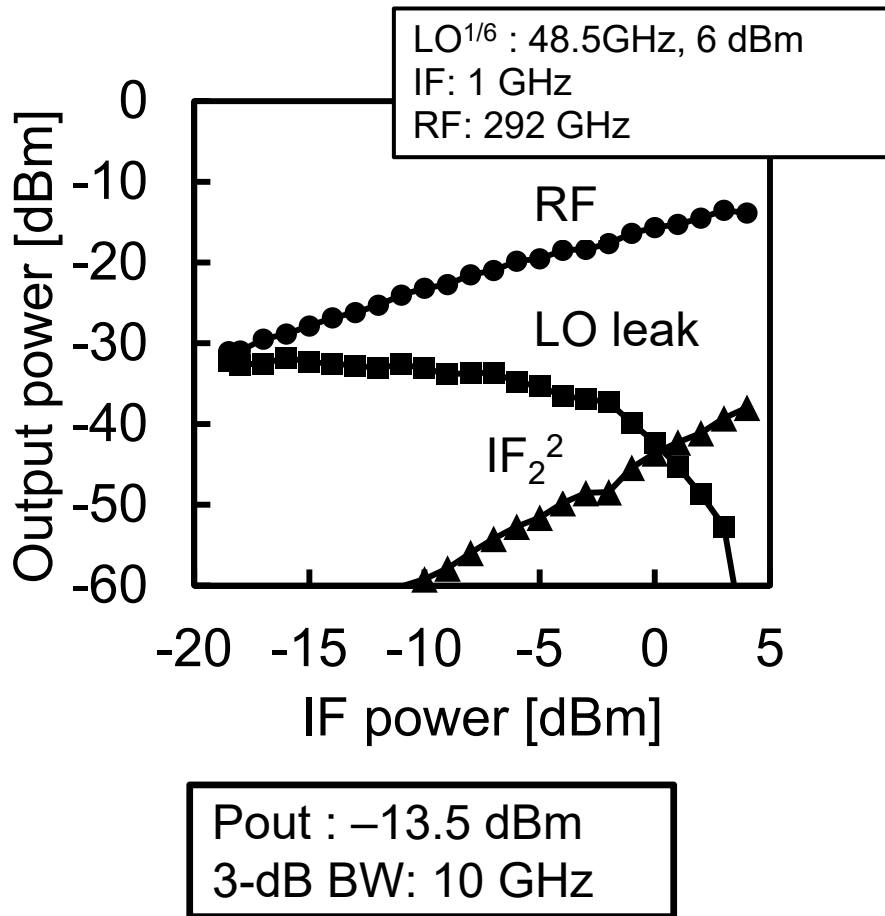

Achieved a wireless data rate of 48 Gbit/s with 16-QAM

[4] K. Takano, et al., RWS2018, pp. 154–156, Jan. 2018.

Performance of RX module and wireless link

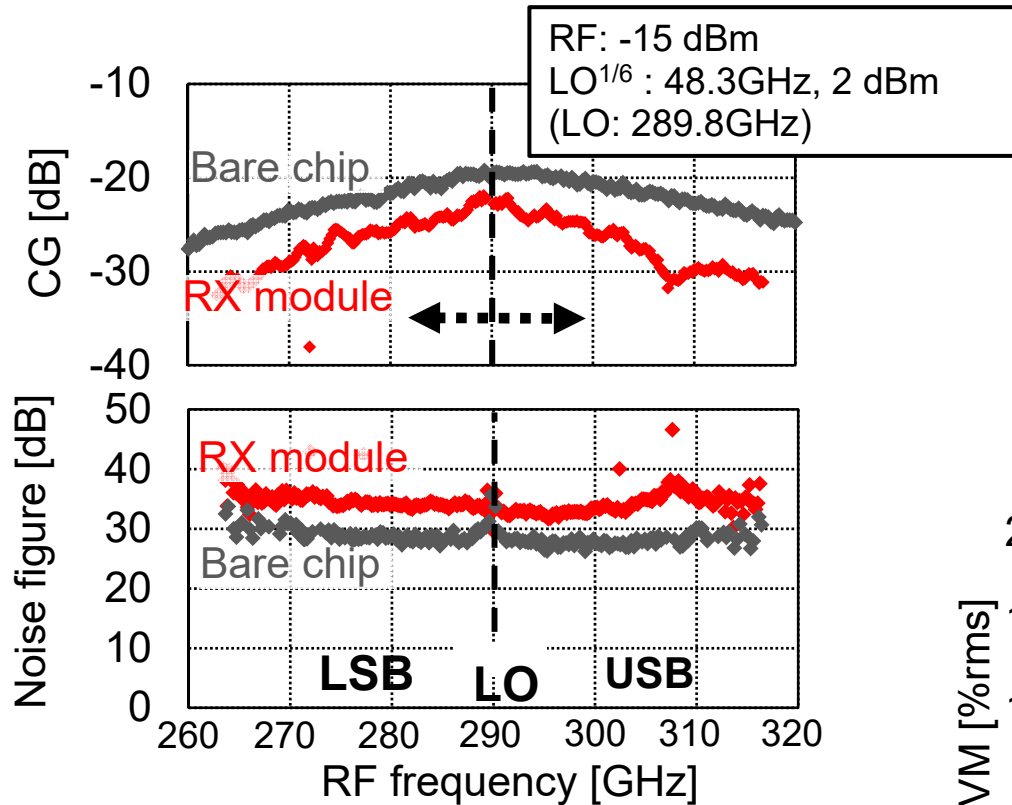

CG peak: 23.7 dB, NF: 33 dB
 3-dB BW : 18.4 GHz

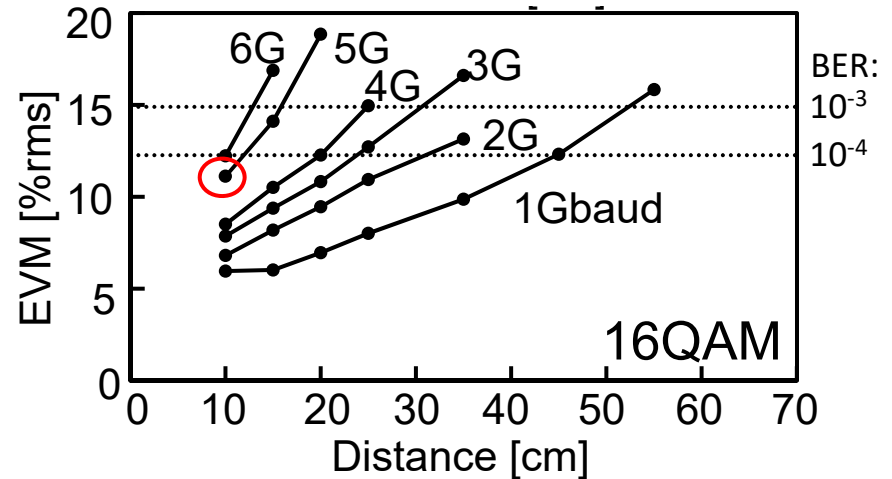
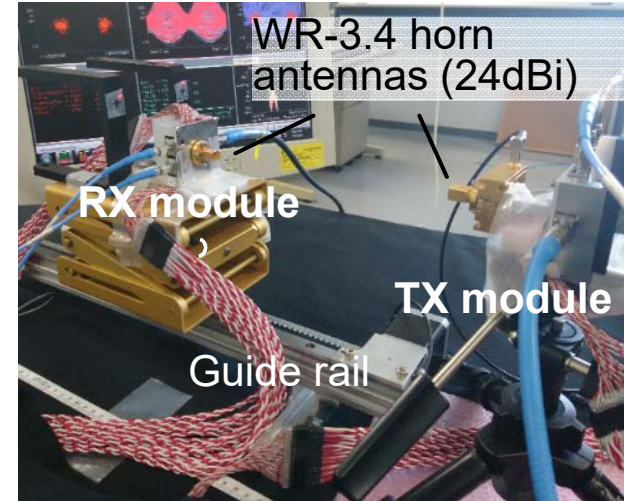

Achieved a wireless data rate of 20 Gbit/s with 16-QAM

[4] K. Takano, et al., RWS2018, pp. 154–156, Jan. 2018. [5] S. Hara, et al., EuMW2018, Sep. 2018.

Towards Ultra-High Throughput FEC Design: EPIC Project

Onur Sahin
InterDigital Europe Ltd.



Exceeding 100 Gb/s Barrier in Wireless Communications

- **Huge available spectrum** potential above 250 GHz to achieve 100 Gb/s and higher throughputs.
 - 252-325 GHz bands already considered under 802.15.3d.
 - Potential bandwidth allocations: 275-450 GHz in WRC 2019 (AI 1.15).
- Substantial progress in **device-level and RF** front-end.
 - THz photonics based RF front-end solutions demonstrate ~100 Gb/s ([1]).
 - 300 GHz Si CMOS transceiver solutions with >100 Gb/s transmitters ([2]).
- **Novel baseband algorithms and architectures** are necessary to enable ultra-high throughputs in THz domain for a wide range of practical use-cases.
 - **FEC** is the most complex and computationally intense component in the baseband chain → A key enabler and challenge for ultra-high throughput/THz communications.

State-of-the-Art FEC for High Throughput Wireless Systems

In existing wireless standards, IEEE 802.11ad*, IEEE 802.15.3d, and 3GPP 5G NR present FEC classes with highest throughput requirements.

- IEEE 802.11ad (Target peak **TP: 7 Gb/s**)
 - Rate (1/2, 5/8, 3/4, 13/16) LDPC with code-word length 672
- IEEE 802.15.3d (Target peak **TP: 100 Gb/s**)
 - Rate 14/15 LDPC (1440,1344)
 - Rate 11/15 LDPC (1440,1056)
- 3GPP 5G NR (Target peak **TP: 20 Gb/s**)
 - Flexible QC-LDPC; 20 Gb/s with rate 8/9 is supported

* 802.11ay amendment (Draft 3.0 stage) targets >20 Gb/s, in addition includes Rate (1/2, 5/8, 3/4, 13/16) LDPC-1344. The decoder architectures are based on 11ad LDPC-672 codes.

State-of-the-Art 802.11ad FEC Implementations: 65/28 nm Silicon [3]

Code	Ref.	Code length	Rate support	Process nm	Area mm ²	Freq MHz	TP Gb/s	Area eff. Gb/s/mm ²	Energy eff. pJ/bit	Power dens. W/mm ²
LDPC	[4]	672	13/16	65	0.16	500	5.6	35	17.65	0.62
LDPC	[5]	672	802.11ad	28	0.78	470	18	23.6	18	0.41
LDPC	[6] 9 iter	672	13/16	28	2.8	220	160	57.1	6	0.32

- The referenced FEC architecture designs, and several others in the literature, comfortably achieve 802.11ad implementation requirements (throughput, power density, energy efficiency).
- Particular designs (e.g. [6]) achieve 160 Gb/s throughput, yet for fixed code-rates and code block-lengths.
- Each design has a different communication performance (BERvsSNR).

State-of-the-Art 802.11ad FEC Implementations: 7 nm Projection [3]

Code	Ref.	Code length	Rate support	Process nm	Area mm ²	Freq MHz	TP Gb/s	Area eff. Gb/s/mm ²	Energy eff. pJ/bit	Power dens. W/mm ²
LDPC	[4]	672	13/16	7	0.003	2923	32	11113	1.9	21.1
						1000	11	3832	1.9	7.2
LDPC	[5]	672	802.11ad	7	0.07	1410	54	830	2.24	3.8
						1000	39	600	2.24	2.7
LDPC	[6]	672	13/16	7	0.2	660.0	480	2057	1.5	3.1
						0.1	480	4100	0.6	3.1

- With 7nm nodes, substantial increase in area efficiency is anticipated.
- Multiple decoder instances of [4], [5], and a few decoder instances in [6] could well-exceed 100 Gb/s throughputs and approach 1 Tb/s.
- However, significant increase in power density and energy efficiency are observed.

Observations on SoA High-throughput FEC Implementation Studies

- SoA implementation studies of 802.11ad LDPC codes demonstrate significant performance gaps in achieving practical ultra-high throughputs (100 Gb/s→Tb/s) **even when taking 7nm performance scaling into account.**
 - Silicon technology evolution to 7nm is expected to provide **sufficient area efficiency gain.**
 - **Power density will emerge as a binding constraint**, with an initial estimate of 10x-100x performance gap between the practical requirements and SoA FEC in 7nm.
 - **Energy efficiency will also be another constraint** with considerable performance gap.
 - **The clock frequency feasible value of 1 GHz** impose additional constraints on ultra-high throughputs – **extreme parallel and unrolled architectures are mandatory.**

Practical Tb/s FEC Implementation KPI Bounds – EPIC Project

New generation of FEC technology to enable ultra-high throughput (Tb/s) wireless communications in 7nm silicon.

EPIC FEC KPI bounds	
Area limit	10 mm ²
Area efficiency limit	100 Gb/s/ mm ²
Energy efficiency limit	~1 pJ/bit
Power density limit	0.1 W/mm ²

- Practical FEC IP **area constraint** on a SoC: 10 mm²
- FEC IP **power budget** to avoid heat removal issues: ~1 W
- FEC decoder **throughput**: 1 Tb/s

- Satisfy stringent communications performance (BER 10⁻⁶ to 10⁻¹²) and flexibility requirements (in terms of e.g. code rates, block length)
- Focus on: **Turbo Codes, LDPC Codes, and Polar Codes.**

Where We are Today in EPIC Project towards 1 Tb/s [7]

OVERVIEW ON IMPLEMENTATION PROPERTIES

Code	Decoding algorithms	Parallel vs. serial	Locality	Compute kernels	Transfers vs. compute
Turbo code	MAP	serial/iterative	low (interleaver)	Add-Compare-select	compute dominated
LDPC code	Belief propagation	parallel/iterative	low (Tanner graph)	Min-Sum/add	transfer dominated
Polar code	Successive cancelation/List	serial	high	Min-Sum/add/sorting	balanced

28nm low V_t FDSOI Technology, worst case PVT, after Place & Route

Code	Blocksize [bit]	Code rate	Frequency [MHz]	Throughput [Gbit/s]	Area [mm ²]	Power [mW]	Area efficiency [Gbit/s/mm ²]	Energy efficiency [pJ/bit]
Turbo code (4 iter)	128	1/3	800	102	23.6	-	4.34	-
LDPC code (9 iter)	672	13/16	400	268	2.8	1500	95.7	5.6
LDPC code (4 iter)	672	13/16	400	268	1.3	700	215	2.5
Polar code	1024	1/2	746	764	2.95	3300	259	4.4

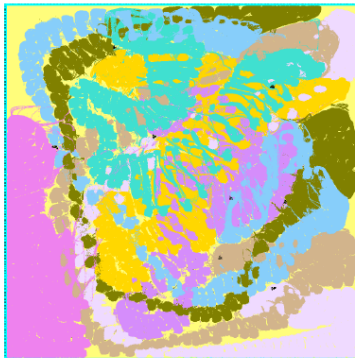

Fig. 1. 102 Gbit/s Turbo code decoder, area 23.61 mm²

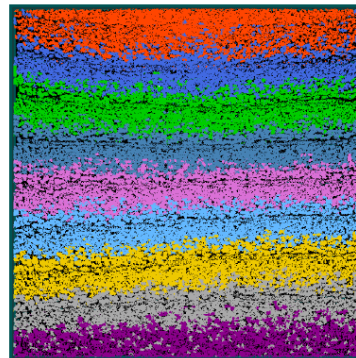

Fig. 2. 268 Gbit/s LDPC code decoder, area 2.8 mm²

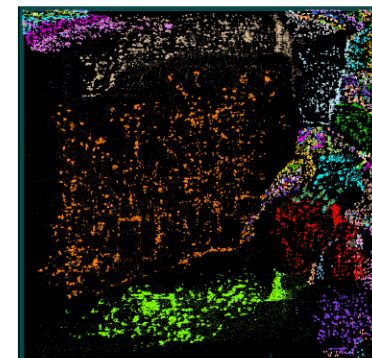

Fig. 3. 764 Gbit/s Polar code decoder, area 2.95 mm²

Challenges for Tb/s Throughput Decoders

Architectural approach

- “Unrolling” of iterations (MAP, Turbo Code, LDPC belief propagation).
- “Flattening” of Polar Factor Tree traversal (SC algorithm).
- Heavy pipelining and spatial parallelism.

Good news

- Throughputs beyond 100 Gbit/s are feasible for all three code classes.

Bad news

- Limited to small block sizes (all three codes) and small number of iterations (Turbo, LDPC) → degrades the communications performance.
- Suffers from limited flexibility in block lengths (all three codes), varying number of iterations (Turbo, LDPC) and code rate flexibility (LDPC, Polar).
- Pipelining increases the latency.
- Power density in the order of 1 W/mm² is far too high for air-cooled package.

Observations for Tb/s Throughput Decoders

Comparison related to implementation Efficiency

- LDPC and Polar code decoder outperform Turbo-Code decoder.
- LDPC and Polar code decoder have similar implementation efficiencies.

Communications performance matters!

- Depends on code, block length, code rate and decoding algorithm.
 - Code impacts decoder complexity; e.g. position of frozen bits for Polar code decoder, structure of H matrix for LDPC code decoding.
- ⇒ A comparison based only on communication performance makes just as little sense as a comparison only on implementation level.
- ⇒ Communication and implementation performance have to be jointly considered.

Design Trade-Offs for Efficient Design

- V_{dd} downscaling of high throughput decoders → Decreases throughput but largely improves energy efficiency.
- Decrease decoder parallelism: E.g. $P \leq 1$ for LDPC belief propagation algorithm → Decreases throughput but improves flexibility.
- More complex decoding algorithms: E.g. SCL for Polar code decoding → Improves communications performance, but decreases throughput, area and energy efficiency.
- Hybrid decoders and concatenated codes: Combination of high throughput and high performance decoders, e.g. Majority-Logic and successive cancellation in Polar codes, inner and outer codes.

Communications Performance

Comparison: LDPC vs Polar Codes

- FEC classes evaluated:
 - **802.15.3d LDPC**: Length-1440, Rate=11/15.
 - **Polar codes**: Length(L) = 2048, 4096, Rate=11/15. List-size=1,2 (CRC=8bits). Density (D) evolution based code design.

Observation:

- Polar code L=4096, List-size=1 and Polar code L=2048, List-size=2 are able to compete with LDPC codes at SNRs greater than 6dB.
- LDPC code experiences degraded performance at high SNRs (>6dB), a critical range for THz use-cases.

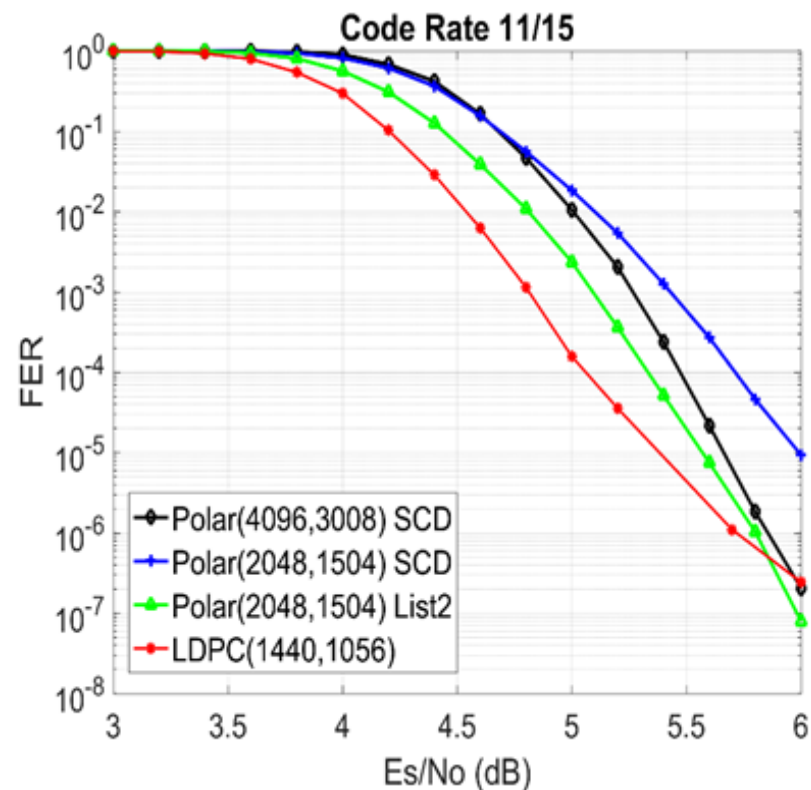

- Modulation: QPSK
- AWGN channel (BH/FH use-case in 802.15.3d study)

Conclusion

- New baseband and FEC solutions are necessary to materialize practical ultra-high throughput (>100 Gb/s) THz communications.
- Progress made in 100 Gb/s→1 Tb/s LDPC and Polar code implementations within THz use-cases practicality constraints.
 - Challenges remain including relatively small block lengths, number of iterations (LDPC and Turbo), and low code flexibility.
 - Power density is a key issue in ultra-high throughput THz!
- A joint study of the two domains, which is often done independently, is mandatory for ultra-high throughput THz communications:
 - New and improved code design with better communications performance
 - FEC architecture design with THz implementation requirements
- The standard 802.15.3d codes lack a detailed implementation study in the literature. A necessary next step to explore their potentials.

EPIC Grant Agreement No. 760150

“The EPIC project has received funding from the European Union’s Horizon 2020 research and innovation programme under grant agreement No 760150.”

If you need further information, please contact the coordinator:

TECHNIKON Forschungs- und Planungsgesellschaft mbH

Burgplatz 3a, 9500 Villach, AUSTRIA

Tel: +43 4242 233 55 Fax: +43 4242 233 55 77

E-Mail: coordination@epic-h2020.eu

The information in this document is provided “as is”, and no guarantee or warranty is given that the information is fit for any particular purpose. The content of this document reflects only the author’s view – the European Commission is not responsible for any use that may be made of the information it contains. The users use the information at their sole risk and liability.

REFERENCES

- [1] Koenig, S., et al. "Wireless sub-THz communication system with high data rate." *Nature Photonics* 7.12 (2013): 977.
- [2] K. Takano, et al., ISSCC2017, pp. 308–309, Feb. 2017.
- [3] O. Sahin, "A Preliminary 7nm implementation and communication performance study of SoA FEC classes for Tbps throughputs", IEEE 802.15 THz IG contribution, Warsaw, Poland, May 7, 2018.
- [4] M. Li, et al., "An area and energy efficient half row-paralleled layer LDPC decoder for the 802.11ad standard," in Proc. IEEE Workshop on Signal Processing Systems (SiPS'13), Taipei City, Oct. 2013, pp. 112–117.
- [5] M. Li, J. W. Weijers, V. Derudder, I. Vos, M. Rykunov, S. Dupont, P. Debacker, A. Dewilde, Y. Huang, L. V. der Perre, and W. V. Thillo, in Solid-State Circuits Conference (A-SSCC), 2015 IEEE Asian, 2015, pp. 1–5.
- [6] S. Scholl, S. Weithoffer, N. Wehn, "Advanced Iterative Channel Coding Schemes: When Shannon meets Moore", in 9th International Symposium on Turbo Codes and Information Processing, pp. 406-411, Invited Talk, 2016, Brest.
- [7] C. Kestel, M. Herrmann, N. Wehn, "When Channel Coding Hits the Implementation Wall", to appear in the proceedings of International Symposium on Turbo Codes & Iterative Information Processing 2018, Hong Kong.

Integration of fiber-optics/THz technologies

Colja Schubert, Robert Elschner, Carlos Castro

Fraunhofer Heinrich Hertz Institute
Tutorial THz Communications

November 2018

Introduction

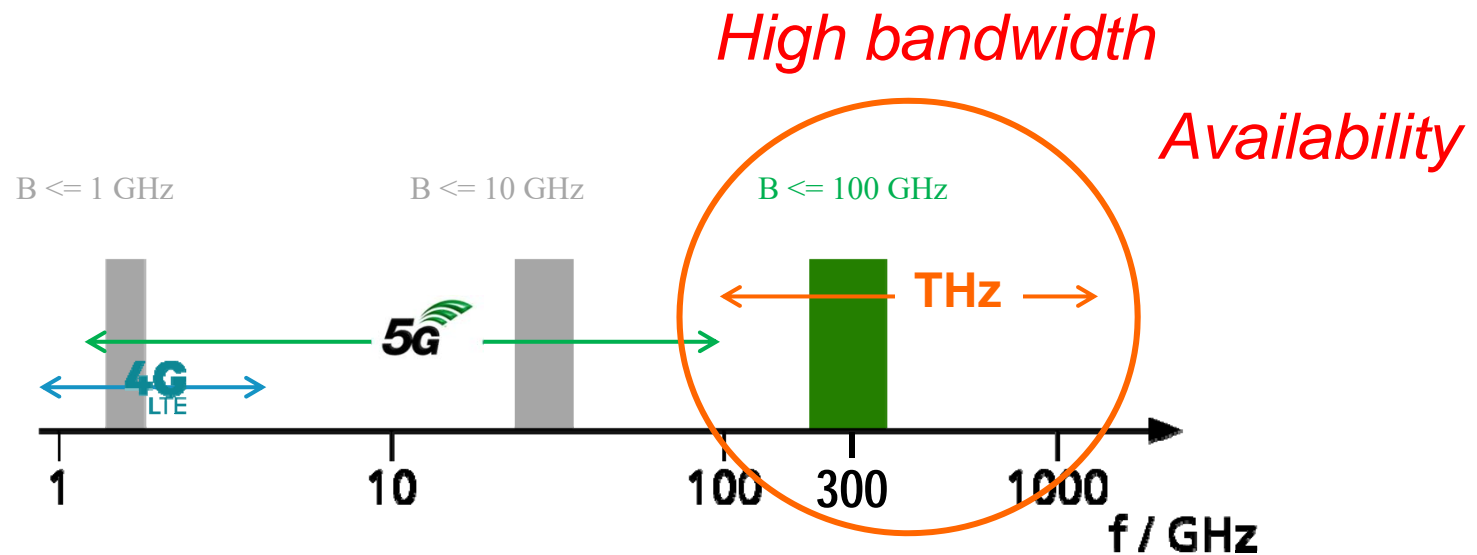

- THz bandwidth is adequate to fit contemporary optical transponder solutions \rightarrow 100/200 Gb/s
- Main question: how can optics and THz technologies be integrated?

Network scenarios

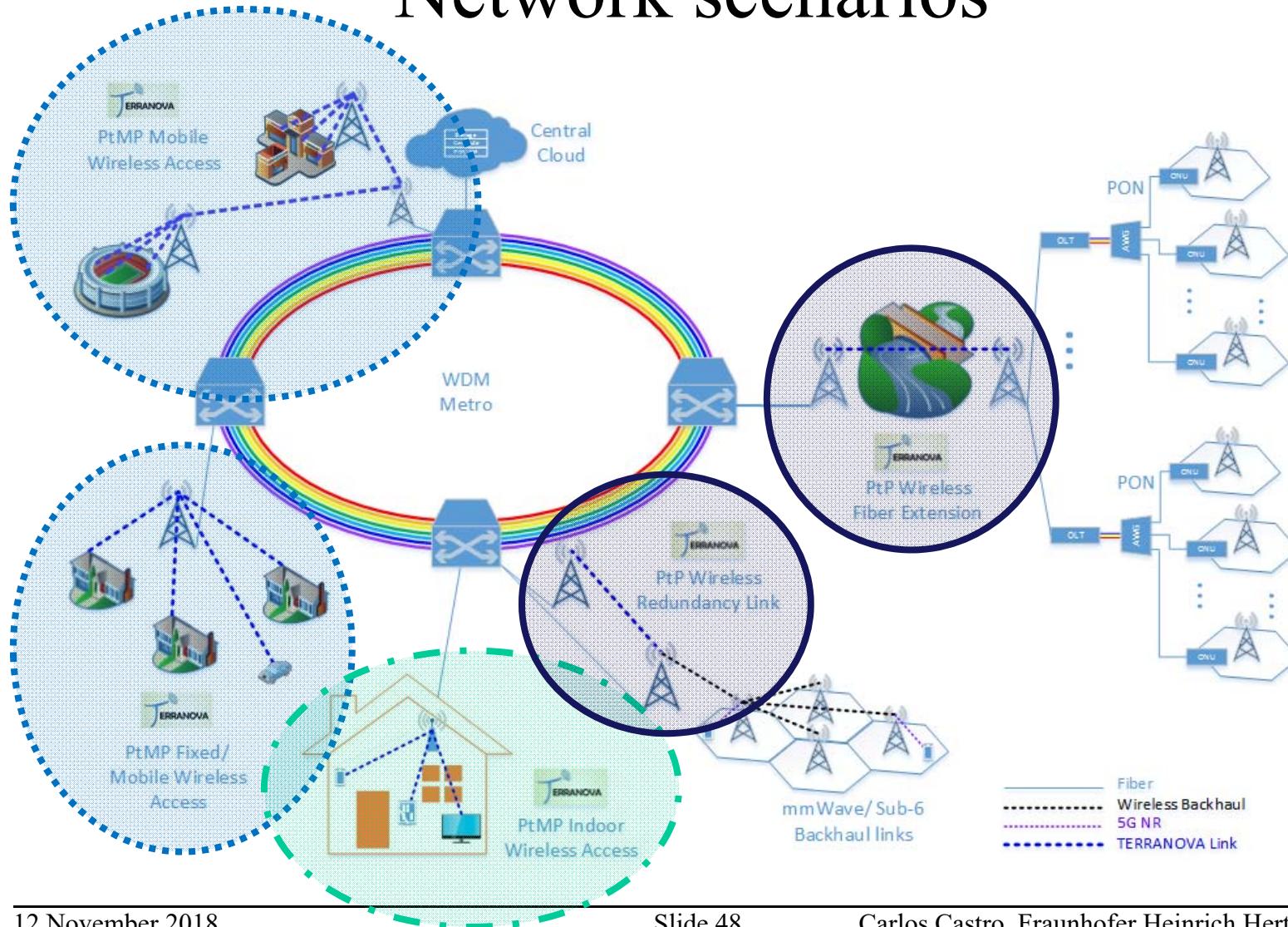

System architectures

- Indoor quasi-omnidirectional
- Point-to-Point
- Point-to-Multipoint

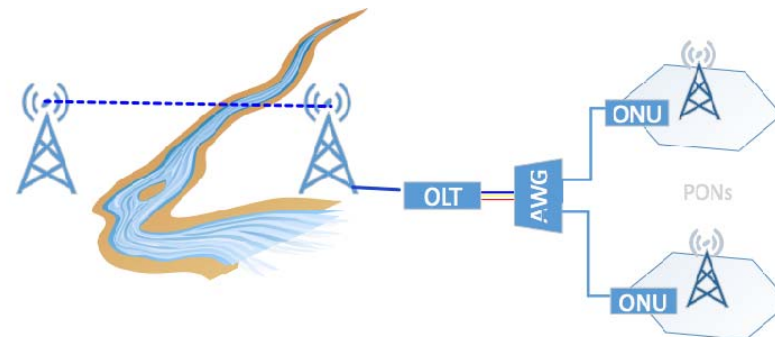
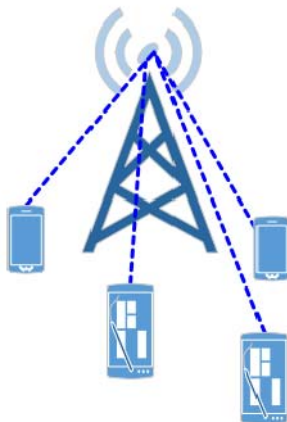
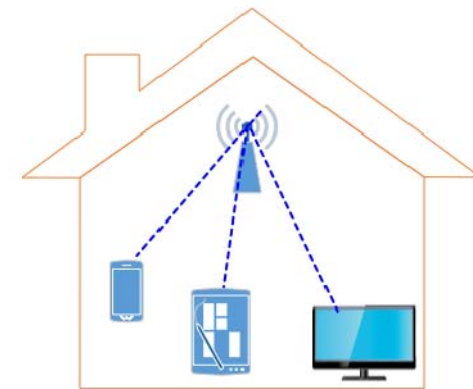

Point-to-point systems

- Stationary/static outdoor connections that require to cover long distances and to support large data rates

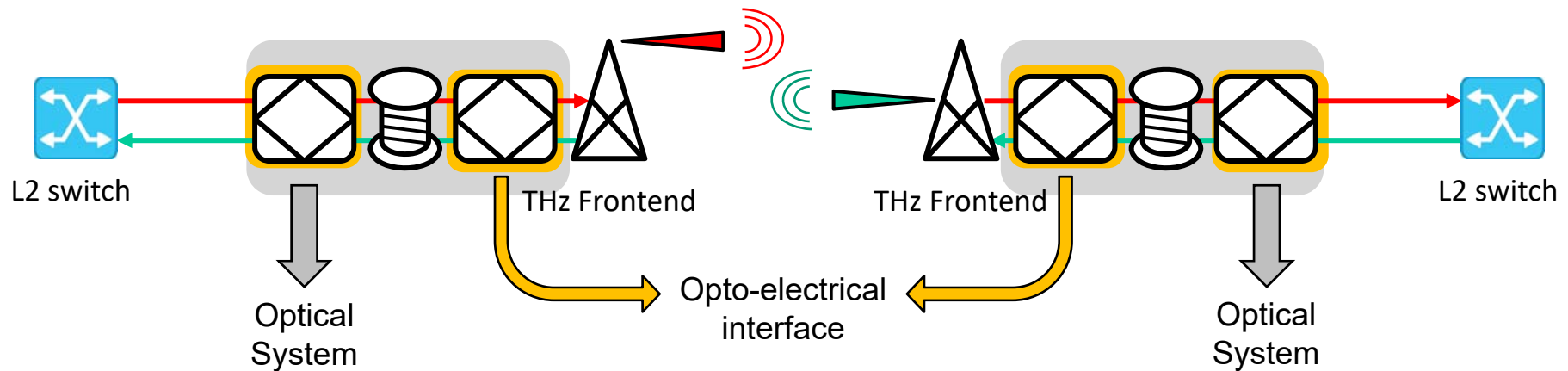

- Target: 1 Tb/s over 1 km wireless link

Optical transceivers



Aspect	CFP	CFP2	CFP8	QSFP28	QSFP-DD
W x L x H [mm]	82 x 145 x 14	41.5 x 106 x 12.4	40 x 102 x 9.5	18.4 x 72 x 8.5	18.35 x 58.26 x 8.5
Power Class	8 W 16 W 24 W 32 W	3 W 6 W 9 W 12 W 15 W 18 W	4 W 8 W 12 W 16 W 20 W 24 W	1.5 W 2 W 2.5 W 3.5 W 4 W 4.5 W 5 W	1.5 W 3.5 W 7.0 W 8.0 W 10 W 12 W 14 W > 14 W
Electrical interface	148 pins 10x10G / 4x25G	104 pins 10x10G / 4x25G 8x25G / 8x50G	124 pins 16x25G / 8x50G 4x100G	38 pins 4x25G	76 pins 8x25G / 8x50G
Application	C-band DCO 100G Single carrier for metro/long-haul	C-band ACO 100G → 200G Reach: tens of meters to thousands of meters	Reach: from tens of meters to couple of kms Equipment interconnection	CWDM4: 4λ x 2km 100G LR: 10 km SR: tens of meters E standard: 40 km	SR: tens of meters Data center intra- connect

Digital systems

- Intensity modulation/Direct detection (IM/DD) systems
 - Information is encoded in different amplitude levels, which are detected by a simple photodiode at Rx
- Subsystems (links) are recognizable along the transmission line
- Advantages: cost-effective
- Disadvantages: reach and data rate
- Most common form-factors: SFP+, QSFP28, XFP, CFP2

Digital system configuration

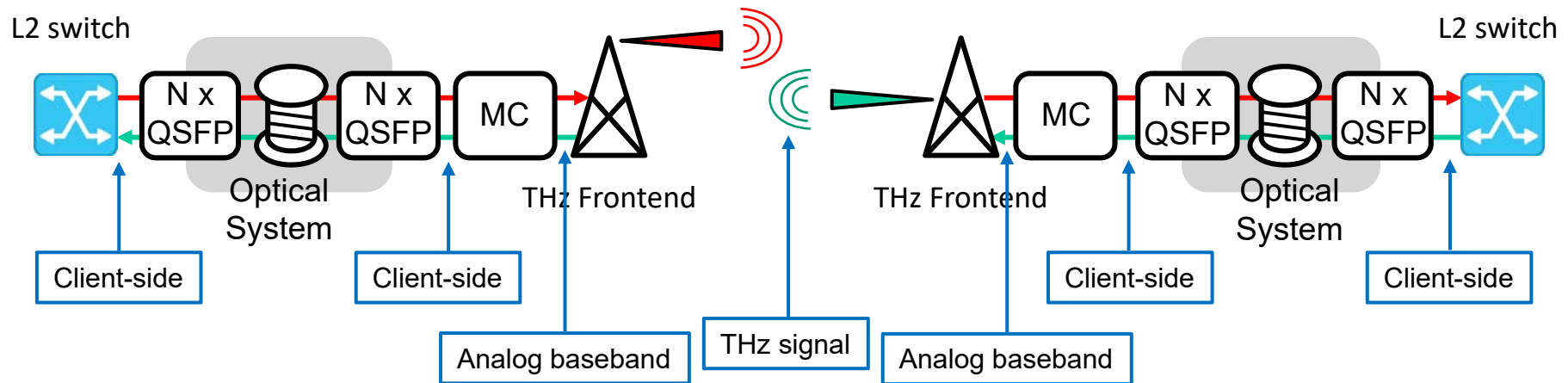

- Multiple QSFP modules act as interfaces between optics and THz
- Media converter (MC) aggregates channels → TDM/FDM
- Data rates: 10 Gb/s → 200 Gb/s
- Challenges: compliance of the media converter with the channel specification (client-side interfaces)

Coherent transmission systems

- Coherent detection is a technique that involves encoding the data both in the amplitude and phase of the optical signal
- Advantages: high spectral efficiency, high data rates, and superior performance
- Disadvantages: more expensive than IM/DD transmission
- Form-factors that currently support coherent transmission are CFP/CFP2 (either DCO or ACO)

Coherent system configuration

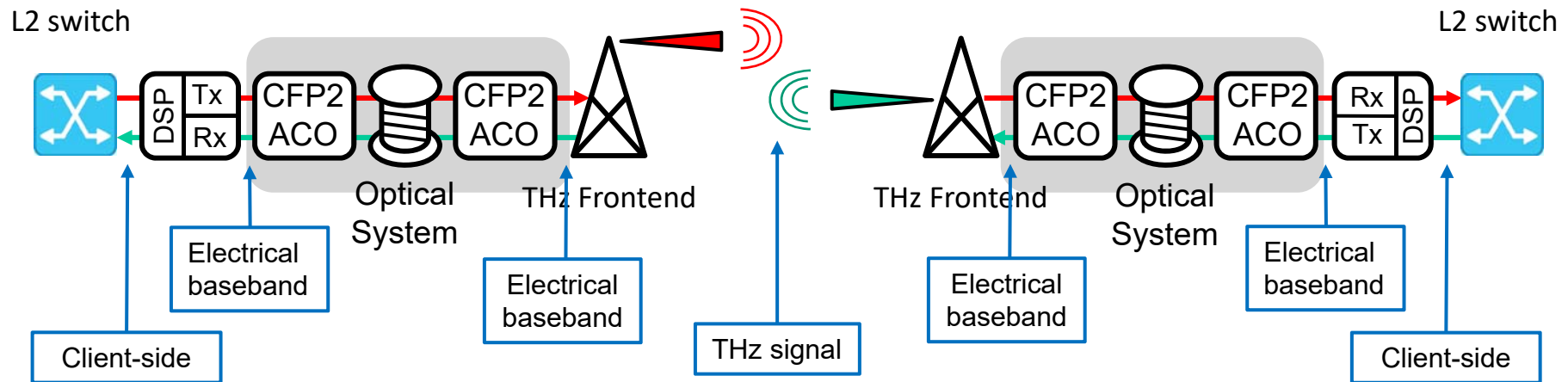

- Standard CFP2-ACO modules act as interfaces between optical and electrical domains
- Transparency of the THz link ('fiber extension')
- Data rates: 100 Gb/s → 500 Gb/s
- Challenges: joint impairment mitigation
→ phase noise, I/Q imbalances, SNR

Good bet to reach the target 1 Tb/s transmission

Overview system configurations

Advantages

Digital systems	Coherent systems
Simple transceiver design	“High” data rates (100-500 Gb/s)
Adjustments based on link conditions	Long-haul optical transmission is possible
Cost-effective	Improved performance (DSP)

Disadvantages

Digital systems	Coherent systems
Short optical distances	Joint impairment mitigation
“Low” data rates (10-200 Gb/s)	Transparent system doesn’t allow to adjust transmission parameters
Interaction media converter/client-side interface	More expensive and complicated systems

Summary

- Applications can be summarized in three large groups: indoor quasi-omnidirectional, point-to-multipoint, and point-to-point
- Interface between the optical domain and the THz elements is critical for a seamless integration of these technologies in the existing communication networks
- There are different approaches to construct an optical/THz system: digital configuration and coherent configuration
- Currently in the process of investigating THz transmission in combination with optical components

Conclusions and Outlook

Thomas Kürner

Technische Universität Braunschweig, Germany

Conclusions

- Frequency bands beyond 275 GHz offer a huge potential to implement wireless communication systems with data rates targeting of more than 100 Gbit/s
- A first 300 GHz standard @ IEEE 802 has been completed in 2017
- Activities targeting allocation of spectrum beyond 275 GHz at WRC 2019 (AI 1.15)
- Ongoing projects towards THz Communications are covering the whole range from Semiconductor Technology (e.g. CMOS) to Physical Layer improvement (e.g. FEC) and Networking (e.g. integration of fibre with THz links)

THz Communications is a real option for wireless networks beyond 5G!

Outlook for IEEE 802 Standardisation

- The THz frequency range may provide various opportunities for the development of further standards or amendments targeting beyond 5G networks
- Examples are standards covering
 - Applications requiring beamforming
 - Systems targeting data rates in Tbps range
 - Seamless integration of fibre with THz wireless links