

Project: IEEE P802.15 Working Group for Wireless Personal Area Networks (WPANs)

Submission Title: A Japanese Activity on 300-GHz CMOS Transmitters

Date Submitted: 6 May 2017

Source: Iwao Hosako, contributors of the research are listed in “Contributors” slide

Company: NICT, Hiroshima University

Address 4-2-1, Nukuikita, Koganei, 184-8795, Tokyo, Japan

Voice: + 81 42 327 6824, FAX: +81 42 327 6669 , E-Mail: kasa@nict.go.jp

Re: []

Abstract: A 300GHz CMOS transmitters (TXs) in 40nm CMOS is presented. With the f_{max} being below 300GHz, it adopts a new PA-less QAM-capable architecture employing the “cubic mixer” and “square mixer”. The output powers of 300GHz CMOS TXs by cubic-mixer- and square-mixer-last architectures are -14.5 and -5.5 dBm, and the data rates of them demonstrate 17.5Gb/s/ch 16QAM transmission over 6 channels and 105Gb/s 32QAM transmission over a single channel, respectively.

Purpose: []

Notice: This document has been prepared to assist the IEEE P802.15. It is offered as a basis for discussion and is not binding on the contributing individual(s) or organization(s). The material in this document is subject to change in form and content after further study. The contributor(s) reserve(s) the right to add, amend or withdraw material contained herein.

Release: The contributor acknowledges and accepts that this contribution becomes the property of IEEE and may be made publicly available by P802.15.

Introduction

- Purpose of this talk is to introduce a Japanese activity on 300-GHz silicon CMOS transmitters and their wireless demonstrations.
- The introduced work was performed by contributors listed in the next slide and financially supported by the Ministry of Internal Affairs and Communications of Japan.

List of Contributors

- Kyoya Takano (Hiroshima University)
- Kosuke Katayama (Hiroshima University)
- Ruibing Dong (Hiroshima University)
- Shuhei Amakawa (Hiroshima University)
- Takeshi Yoshida (Hiroshima University)
- Minoru Fujishima (Hiroshima University)
- Shinsuke Hara (NICT)
- Akifumi Kasamatsu (NICT)

Outline

- Background of 300GHz wireless communication
- 300GHz CMOS TXs
 - 300GHz CMOS TX by cubic-mixer-last architecture
[1] K. Katayama et al., ISSCC2016
 - 300GHz CMOS TX by square-mixer-last architecture
[2] K. Takano et al., ISSCC2017
- Performance comparison
- Wireless demonstration of the 300GHz CMOS TXs
- Conclusion

Outline

- Background of 300GHz wireless communication
- 300GHz CMOS TXs
 - 300GHz CMOS TX by cubic-mixer-last architecture
[1] K. Katayama et al., ISSCC2016
 - 300GHz CMOS TX by square-mixer-last architecture
[2] K. Takano et al., ISSCC2017
- Performance comparison
- Wireless demonstration of the 300GHz CMOS TXs
- Conclusion

Possible applications of 300GHz wireless communication

- Enormous potential for THz wireless communication

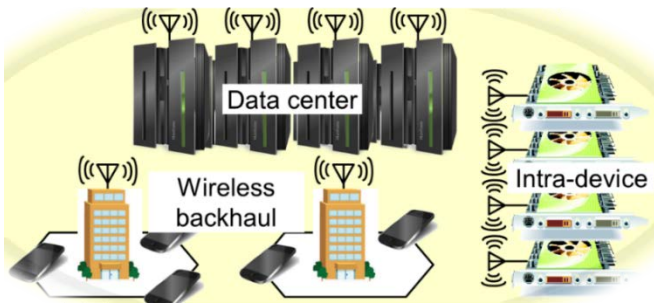

Ultrahigh-speed wireless communications

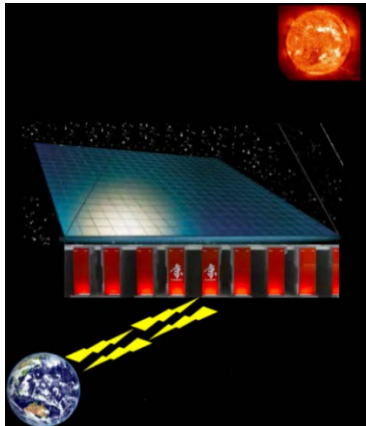

THz communication with super computer in outer space

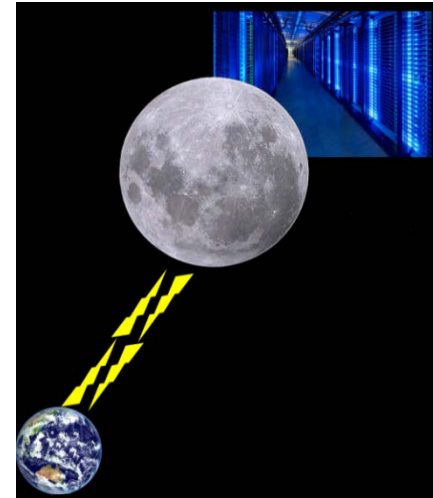

THz communication with cold storage center on outer space

M. Fujishima, Keysight world 2016 Tokyo (14 June, 2016)

300GHz CMOS transmitters (TXs)

- ✓ QAM-capable 300GHz CMOS TX with 17.5Gb/s/ch [1]
- ✓ 300GHz CMOS TX over 100Gb/s [2]
in 40nm CMOS (f_{\max} : ~280GHz)

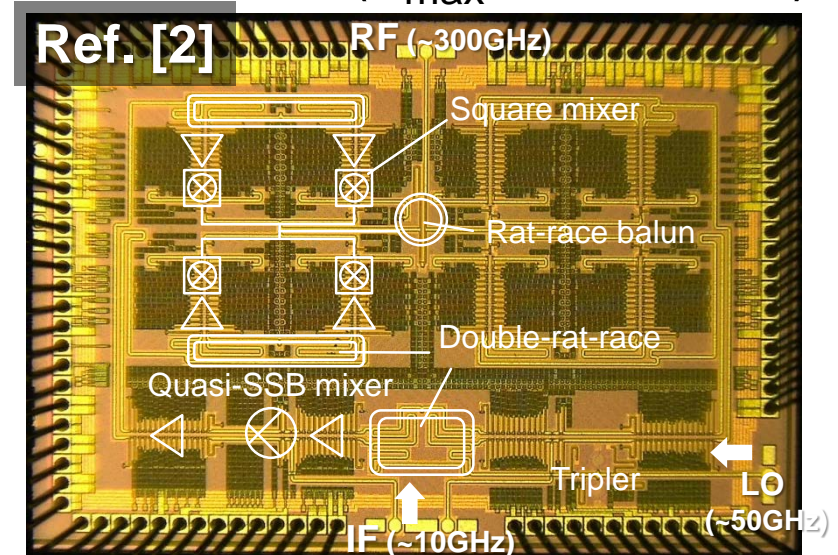
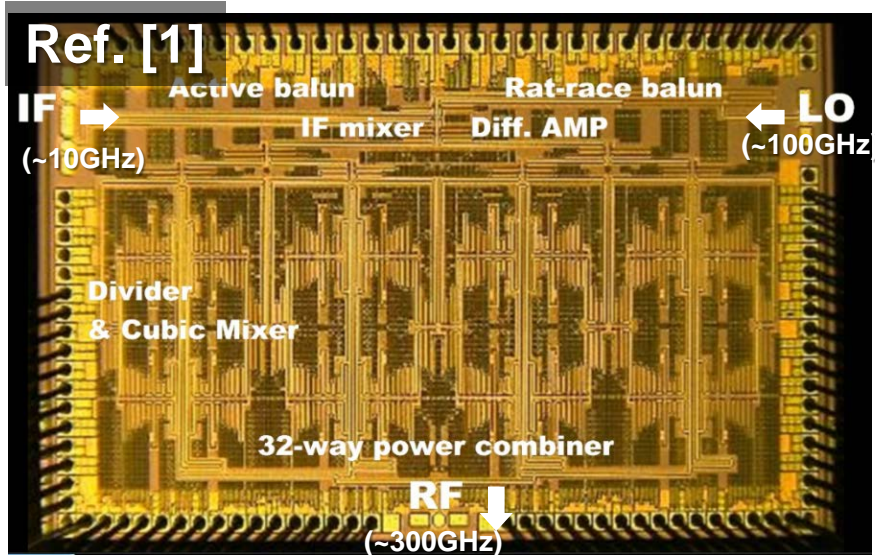

[1] K. Katayama, K. Takano, S. Amakawa, S. Hara, A. Kasamatsu, K. Mizuno, K. Takahashi, T. Yoshida, M. Fujishima, "A 300GHz 40nm CMOS Transmitter with 32-QAM 17.5Gb/s/ch Capability over 6 Channels," *Int. Solid-State Circuits Conf. (ISSCC2016)*, pp. 342–343, Feb. 2016.

[2] K. Takano, S. Amakawa, K. Katayama, S. Hara, R. Dong, A. Kasamatsu, I. Hosako, K. Mizuno, K. Takahashi, T. Yoshida, M. Fujishima, "A 105Gb/s 300GHz CMOS Transmitter," *Int. Solid-State Circuits Conf. (ISSCC2017)*, pp. 308–309, Feb. 2017.

300GHz CMOS transmitters (TXs)

- ✓ QAM-capable 300GHz CMOS TX with 17.5Gb/s/ch [1]
- ✓ 300GHz CMOS TX over 100Gb/s [2]
in 40nm CMOS (f_{max} : ~280GHz)

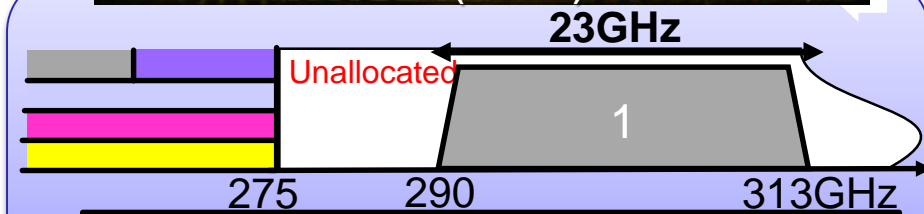
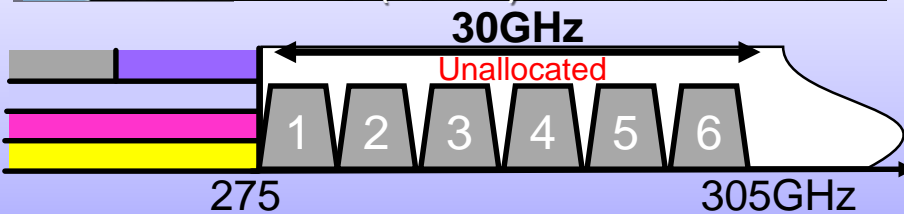
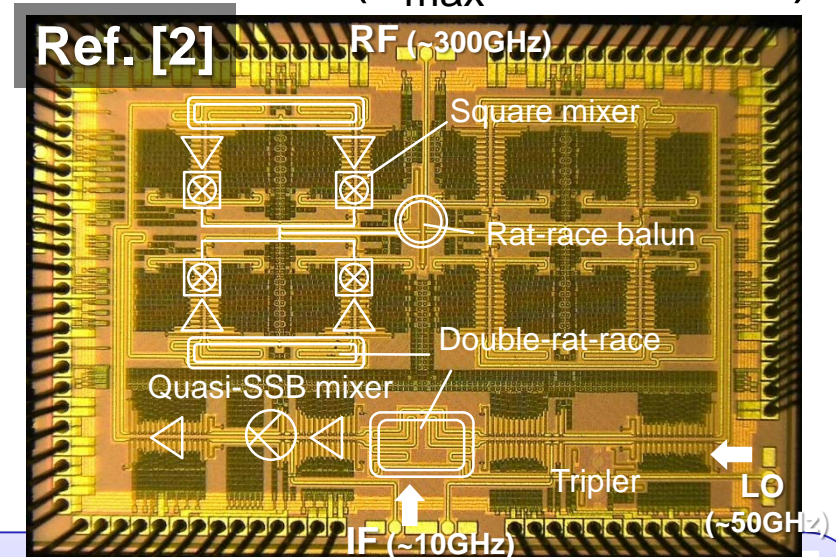
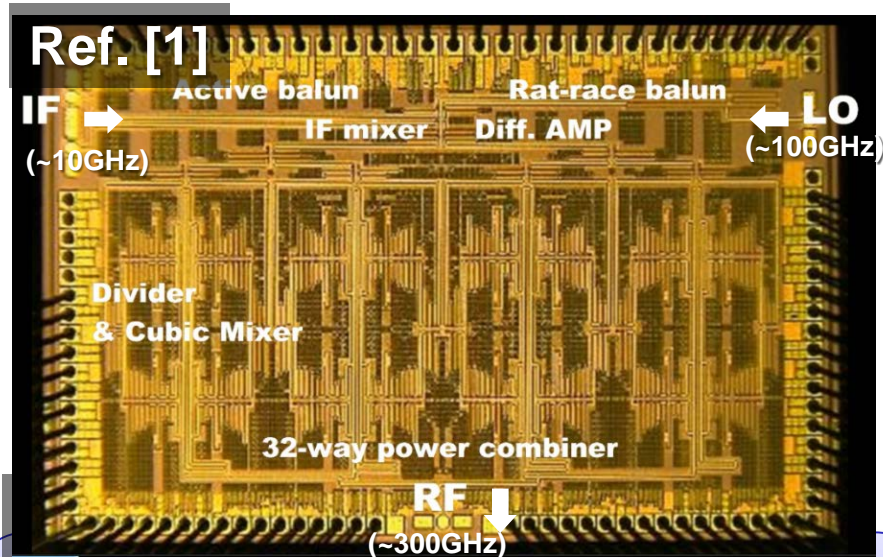

32QAM 3.5Gbaud → 17.5Gb/s/ch (× 6)

32QAM 21Gbaud → 105Gb/s

Outline

- Background of 300GHz wireless communication
- 300GHz CMOS TXs
 - 300GHz CMOS TX by cubic-mixer-last architecture
[1] K. Katayama et al., ISSCC2016
 - 300GHz CMOS TX by square-mixer-last architecture
[2] K. Takano et al., ISSCC2017
- Performance comparison
- Wireless demonstration of the 300GHz CMOS TXs
- Conclusion

THz transmitters (TXs): State of the art

■ TXs architecture depends on transistor f_{max}

f_{max} : Unity-power-gain frequency

THz TX Architecture

Spectrum QPSK 16QAM

PA-last

$f_{MAX} > RF$
→ III-V

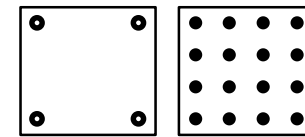
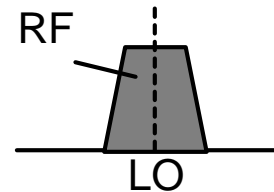
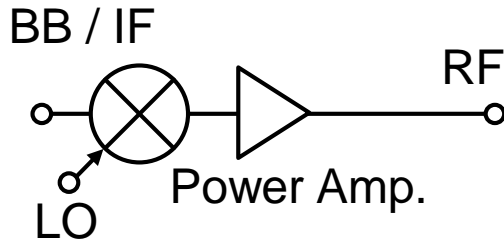

High power
QAM-capable

Multiplier-last

$f_{MAX} < RF$
→ CMOS

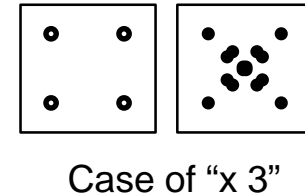
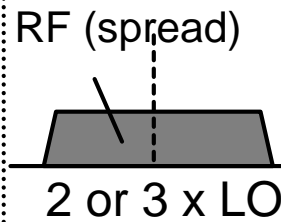
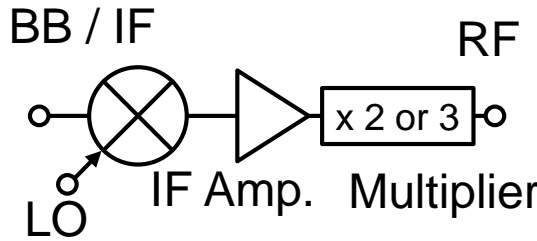

Low power
QAM-incapable

Mixer-last

$f_{MAX} < RF$
→ CMOS

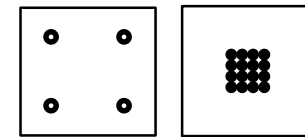
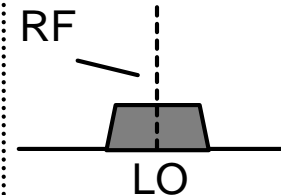
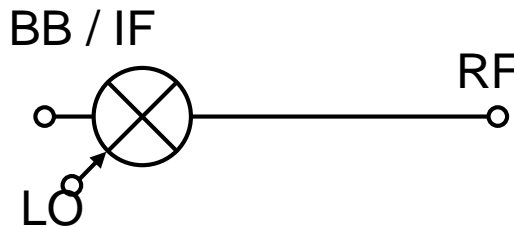

Low power
QAM-capable
Complicated layout

[1] K. Katayama, et al. *ISSCC2016*, pp. 342–343, Feb. 2016.

THz transmitters (TXs): State of the art

■ Technical challenges

300GHz PA-less TX in CMOS operating beyond f_{max} ,

- ✓ QAM-capability for high data-rates
- ✓ Without undue layout complication

Multiplier-last

$f_{MAX} < RF$
→ CMOS

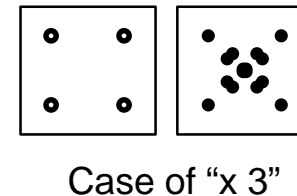
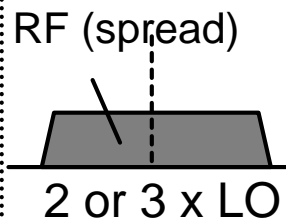
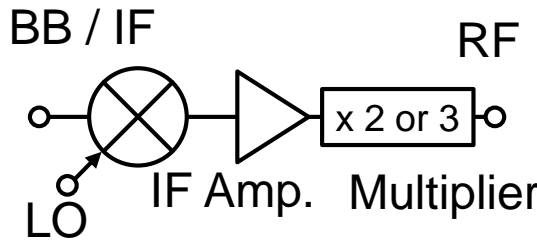

Low power
QAM-incapable

Mixer-last

$f_{MAX} < RF$
→ CMOS

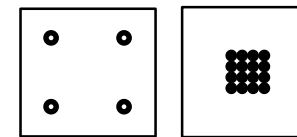
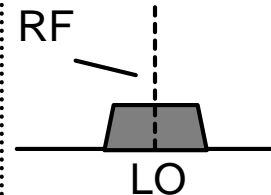
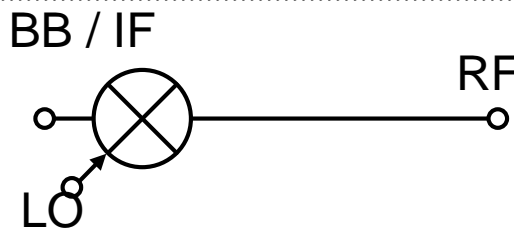

Low power
QAM-capable
Complicated layout

[1] K. Katayama, et al. *ISSCC2016*, pp. 342–343, Feb. 2016.

Design

■ Cubic-mixer-last architecture (ISSCC2016)

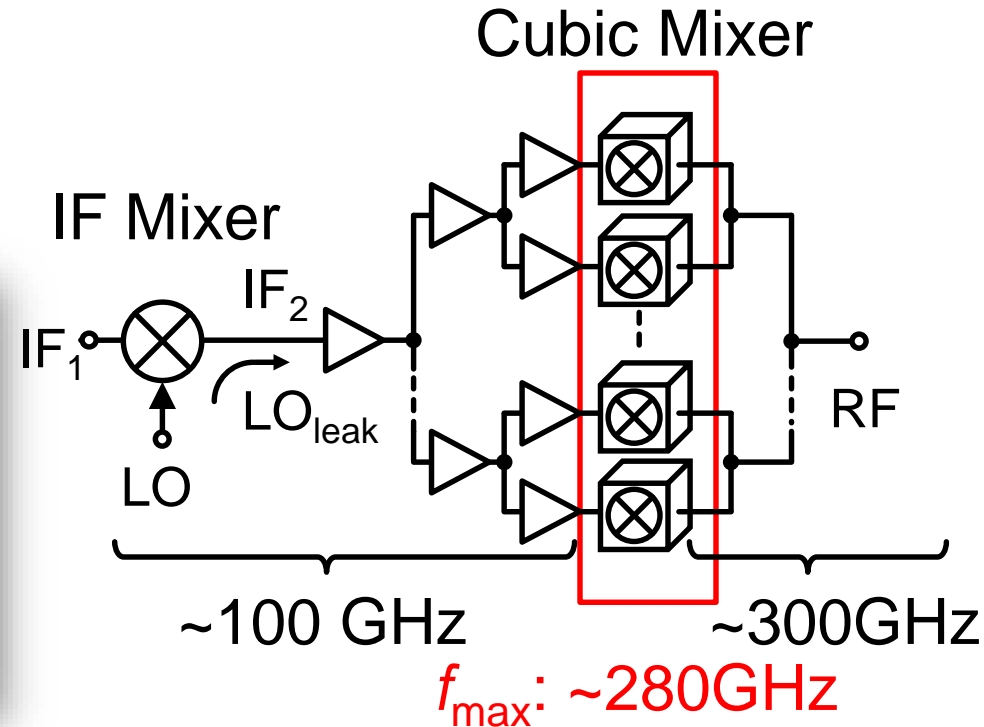
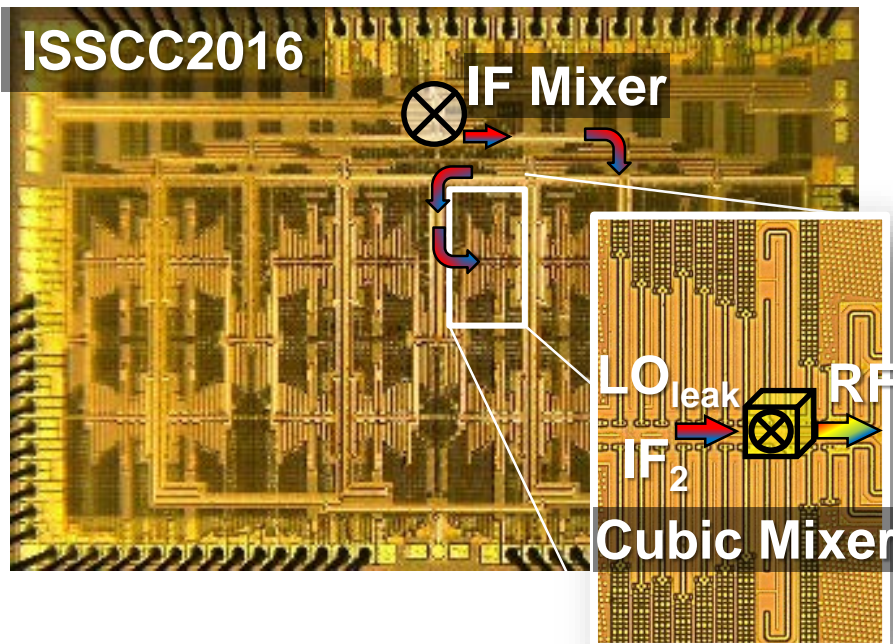

- Cubic mixer is essentially a **tripler**
- It receives superposition of IF₂ (modulated) and LO (pure)

[1] K. Katayama, et al. *ISSCC2016*, pp. 342–343, Feb. 2016.



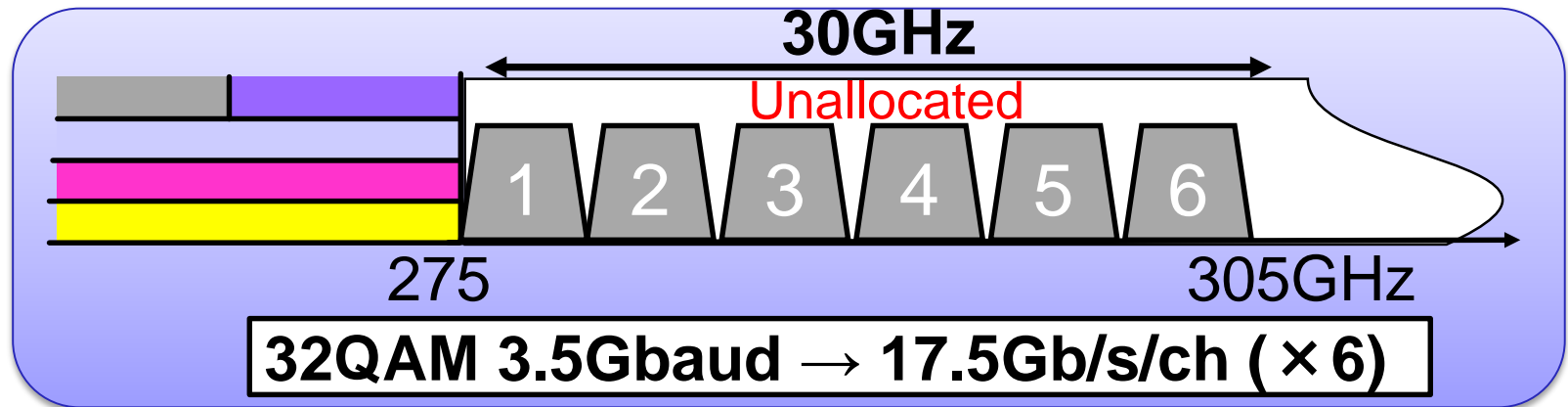
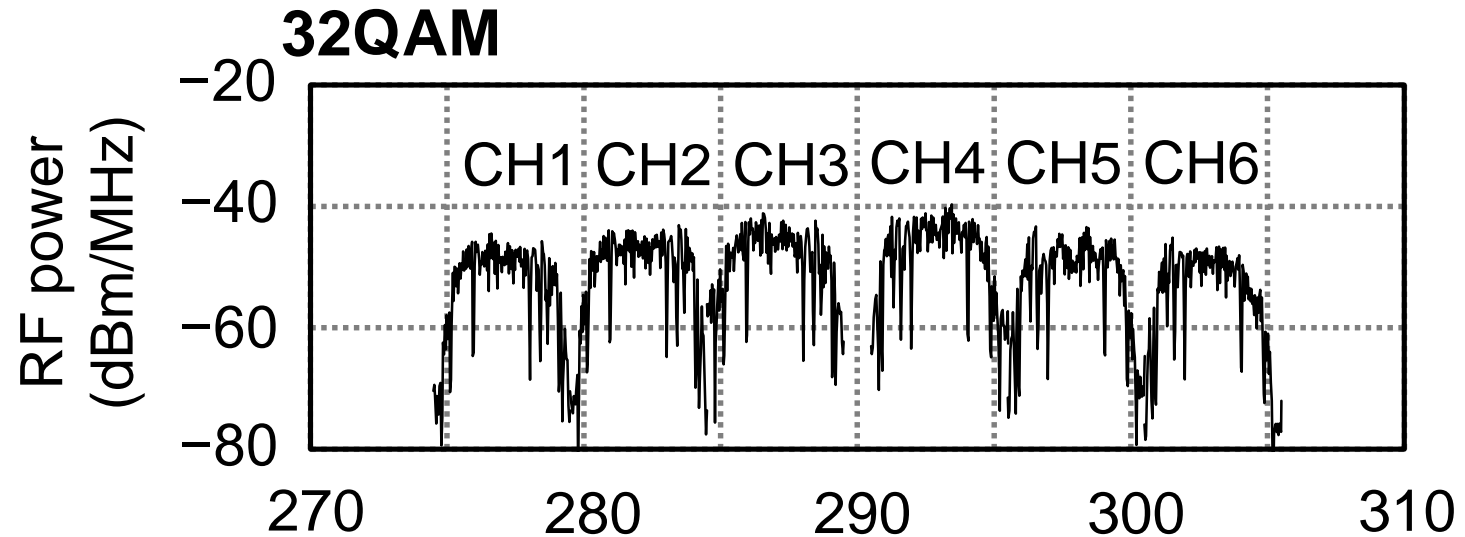



Power spectra and signal constellations



[1] K. Katayama, et al. *ISSCC2016*, pp. 342–343, Feb. 2016.

Power spectra and signal constellations

32QAM

Channel	CH1	CH2	CH3
Constellation (Equalized)			
EVM	8.9%rms	4.8%rms	7.0%rms
Data-rate	17.5Gb/s	17.5Gb/s	17.5Gb/s
Channel	CH4	CH5	CH6
Constellation (Equalized)			
EVM	7.1%rms	6.4%rms	5.9%rms
Data rate	17.5Gb/s	17.5Gb/s	17.5Gb/s

➤ Aggregate data-rate reaches 105Gb/s

[1] K. Katayama, et al. *ISSCC2016*, pp. 342–343, Feb. 2016.

Outline

- Background of 300GHz wireless communication
- 300GHz CMOS TXs
 - 300GHz CMOS TX by cubic-mixer-last architecture
[1] K. Katayama et al., ISSCC2016
 - 300GHz CMOS TX by square-mixer-last architecture
[2] K. Takano et al., ISSCC2017
- Performance comparison
- Wireless demonstration of the 300GHz CMOS TXs
- Conclusion

Design

■ Square mixer + quasi-SSB mixer (ISSCC2017)

Quasi-SSB mixer Square mixer

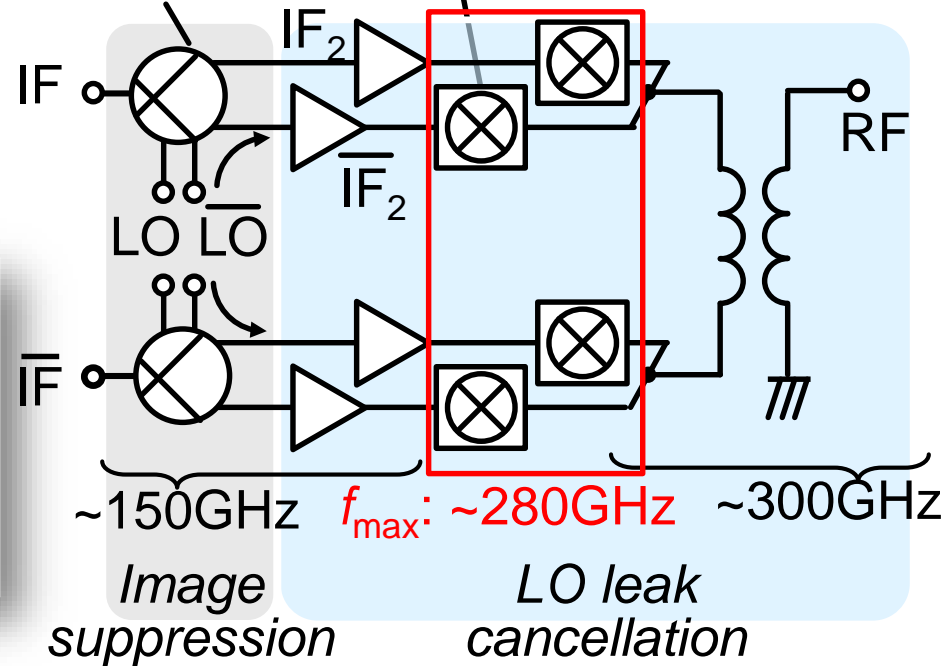
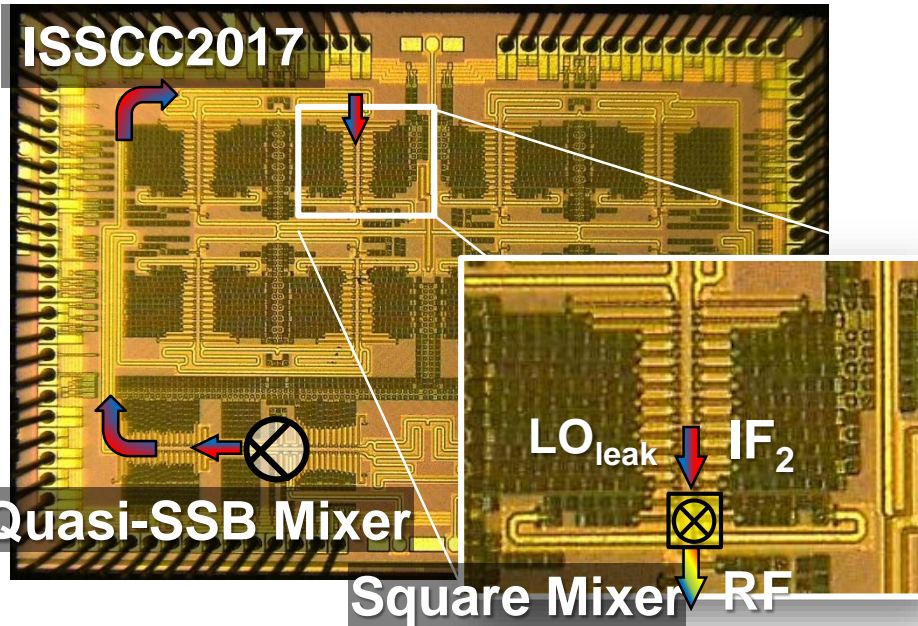

- Square mixer is essentially a **doubler**
- Quasi-SSB mixer includes filters for image suppression

[2] K. Takano, et al. *ISSCC2017*, pp. 308–309, Feb. 2017.

Power spectra and signal constellations

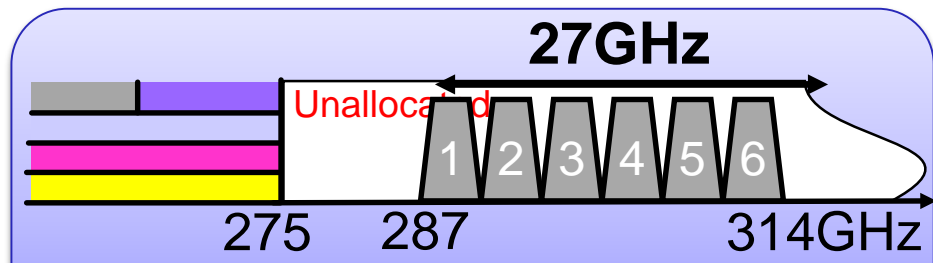
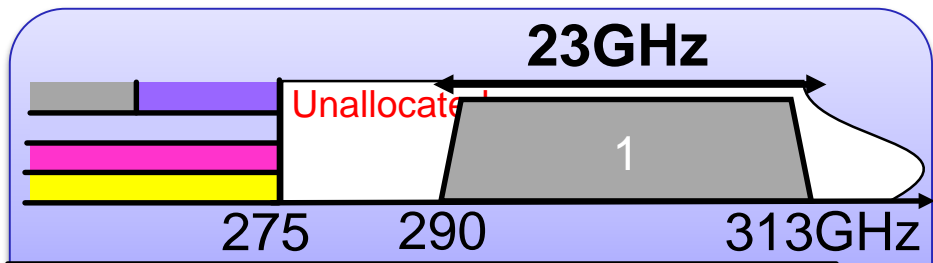
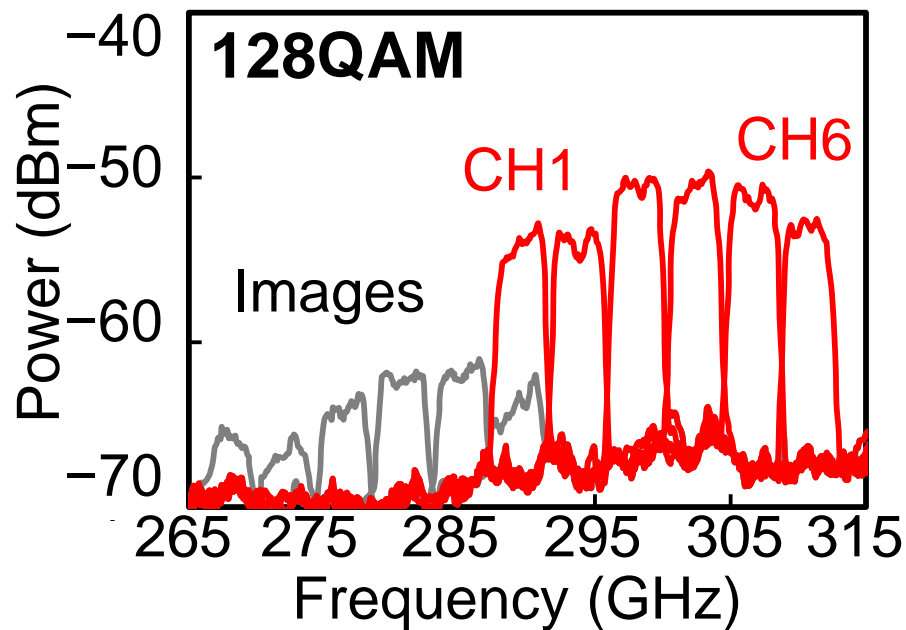
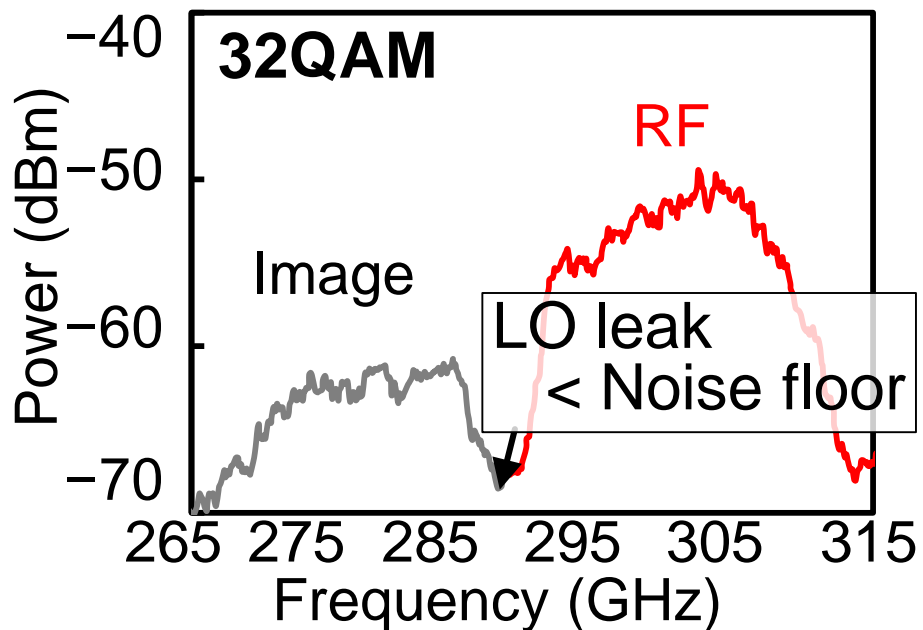

32QAM 21Gbaud → 105Gb/s

128QAM 3.52Gbaud → 24.6Gb/s/ch (× 6)

[2] K. Takano, et al. *ISSCC2017*, pp. 308–309, Feb. 2017.

Power spectra and signal constellations

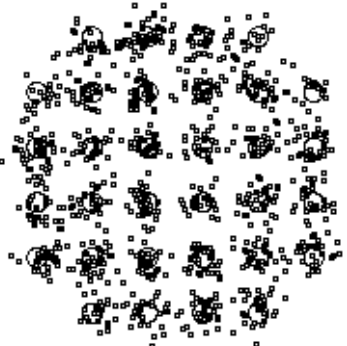
Modulation	32QAM
Constellation (Equalized)	
EVM	8.9%
Data rate	105Gb/s

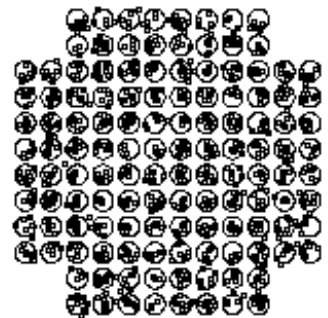
Modulation	128QAM
Constellation (Equalized)	
EVM	3.3 ~ 4.1%
Data rate	24.64Gb/s x6

[2] K. Takano, et al. *ISSCC2017*, pp. 308–309, Feb. 2017.

Outline

- Background of 300GHz wireless communication
- 300GHz CMOS TXs
 - 300GHz CMOS TX by cubic-mixer-last architecture
[1] K. Katayama et al., ISSCC2016
 - 300GHz CMOS TX by square-mixer-last architecture
[2] K. Takano et al., ISSCC2017
- **Performance comparison**
- Wireless demonstration of the 300GHz CMOS TXs
- Conclusion

Performance comparison

	[1]	[2]		[3]	[4]	[5]	[6]
Technology	40nm CMOS	40nm CMOS		250nm InP	35nm GaAs	35nm GaAs	0.13 μ m SiGe
Freq. (GHz)	300	302	289–311	300	240	300	240
Modulation	16QAM	32QAM	128QAM	QPSK	8PSK	QPSK	64QAM
Pout (dBm)	-14.5	-5.5		-	-3.5	-4	7
Pdc (W)	1.4	1.4		-	-	-	0.54
Data rate (Gb/s)	28	105	24.64 x 6	50	96	64	1.02

[1] K. Katayama et al., ISSCC2016.

[2] K. Takano et al., ISSCC2017.

[3] Song et al., TMTT, 2014.

[4] Boes et al., IRMMW-THz, 2014.

[5] Kallfass et al., IEICE Trans., 2015.

[6] Sarmah et al., TMTT, 2016..

Outline

- Background of 300GHz wireless communication
- 300GHz CMOS TXs
 - 300GHz CMOS TX by cubic-mixer-last architecture
[1] K. Katayama et al., ISSCC2016
 - 300GHz CMOS TX by square-mixer-last architecture
[2] K. Takano et al., ISSCC2017
- Performance comparison
- **Wireless demonstration of the 300GHz CMOS TXs**
- Conclusion

Wireless demonstration

300GHz CMOS TX
by cubic-mixer-last-architecture

Ref. [1]

300GHz CMOS TX
by square-mixer-last-architecture

Ref. [2]

Video Contents

[1] K. Katayama, et al. *ISSCC2016*, pp. 342–343, Feb. 2016.

[2] K. Takano, et al. *ISSCC2017*, pp. 308–309, Feb. 2017.

Outline

- Background of 300GHz wireless communication
- 300GHz CMOS TXs
 - 300GHz CMOS TX by cubic-mixer-last architecture
[1] K. Katayama et al., ISSCC2016
 - 300GHz CMOS TX by square-mixer-last architecture
[2] K. Takano et al., ISSCC2017
- Performance comparison
- Wireless demonstration of the 300GHz CMOS TXs
- **Conclusion**

Conclusion

- A Japanese activity on 300-GHz silicon CMOS transmitters and their wireless demonstrations were introduced.
- QAM-capable 300GHz TXs in 40-nm CMOS operating beyond f_{\max} were reported.
 - cubic-mixer-last architecture
[1] K. Katayama et al., ISSCC2016.
 - square-mixer-last architecture
[2] K. Takano et al., ISSCC2017.
- For realizing 300GHz wireless communication, Si CMOS is one of possible technology.