

Project: IEEE P802.15 Working Group for Wireless Personal Area Networks (WPANs)

Submission Title: How to derive the Channel Impulse Response from a broadband Channel Transfer Function?

Date Submitted: 13. March, 2016

Source: Sebastian Rey, Technische Universität Braunschweig

Address: Schleinitzstr. 22, D-31806 Braunschweig, Germany

Voice: +49-531-391-2439, FAX: +49-531-391-5192, E-Mail: rey@ifn.ing.tu-bs.de

Abstract: This presentation provides guidance how the channel impulse response can be derived in the equivalent baseband region for link-level simulations.

Purpose: Providing guidance.

Notice: This document has been prepared to assist the IEEE P802.15. It is offered as a basis for discussion and is not binding on the contributing individual(s) or organization(s). The material in this document is subject to change in form and content after further study. The contributor(s) reserve(s) the right to add, amend or withdraw material contained herein.

Release: The contributor acknowledges and accepts that this contribution becomes the property of IEEE and may be made publicly available by P802.15.

How to derive the Channel Impulse Response from a broadband Channel Transfer Function?

Sebastian Rey¹, Thomas Kürner¹

¹ Institut für Nachrichtentechnik, Technische Universität Braunschweig, Germany

Outline

- 1. Deriving the Channel Impulse Response
in the equivalent baseband region
from the broadband Channel Transfer Function
for link-level simulations**
2. “Synchronizing” the Channel Impulse Response
(CIR from broadband CTF does not include
the synchronization a receiver preforms)
3. Summary
4. Reference

Details of the Problem

- Every Textbook says: $h(t) = \mathcal{F}^{-1}\{H(f)\}$
(This is correct, of course!)
- But

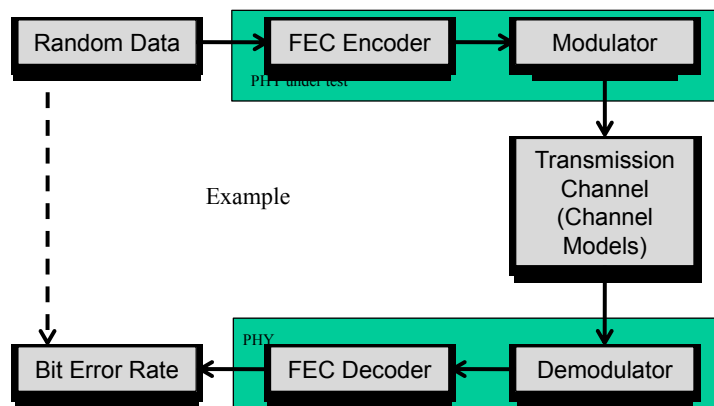

From IEEE 802.15-15-0219-01-003d

- we have a sampled **Channel Transfer Function (CTF) $H(f)$** in the so called bandpass region
- we want the **Channel Impulse Response (CIR) $h(t)$** in the equivalent baseband region
- we use an ifft not a continuous inverse Fourier Transformation (ifft is used in this presentation though in application you may have to use idft)

- In the remainder of this presentation MATLAB code will be given as an example (in green).
- The code examples can be reproduced with every programming language but some lines of code depend on the implementation of certain commands in that language. These lines are marked.

Definitions & Example

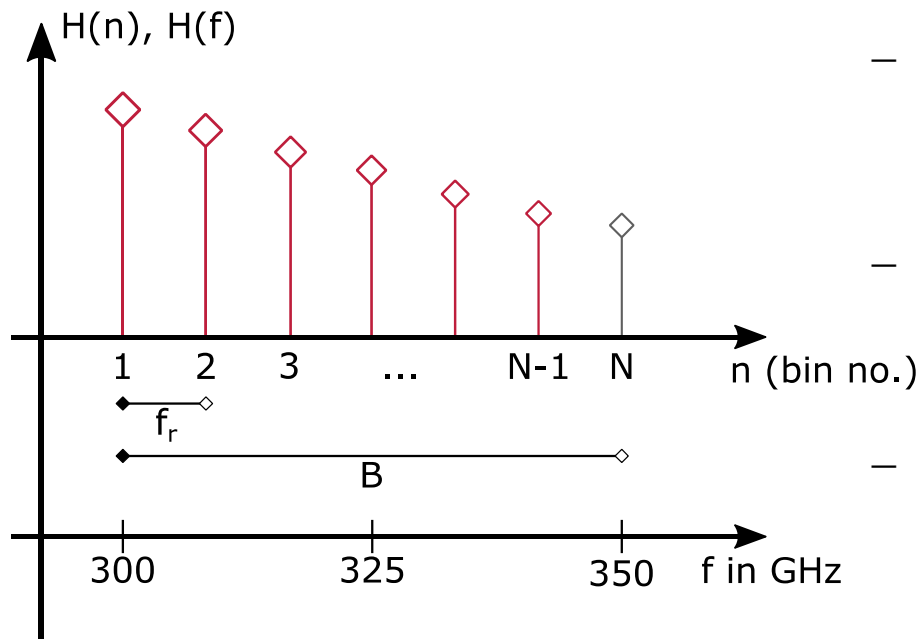

- array $H(n)$ with N complex values
- represents $H(f)$, e.g.:
 - $f = 300$ to 350 GHz
 - bandwidth $B = 50$ GHz
- frequency resolution $f_r = \frac{B}{N-1}$
- often uneven number of bins to include the upper end, e.g. $N = 5001$ for 50 GHz; this leads to $f_r = 10$ MHz
- So: $h = \text{ifft}(H(1:\text{end}))$; ?
 (**No**, but see the explanation on the next slides).

Deriving the CIR – 1 –

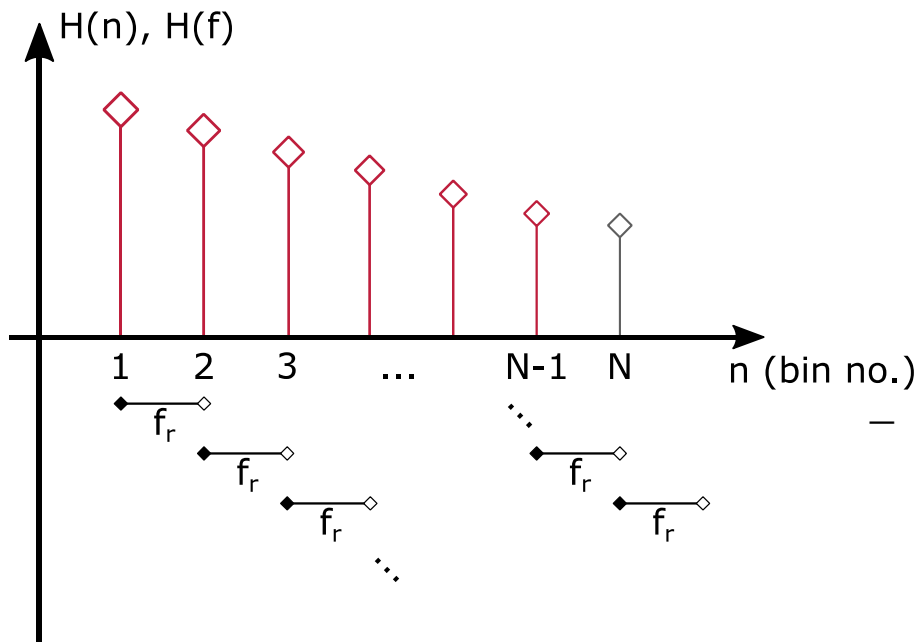

(Of course the 1. problem can be solved by not storing the last bin right from the beginning)

- Two reasons why the CIR is not $\mathbf{h = ifft(H(1:end))};$
 1. Bandwidth definition for ifft
 2. We are looking for the CIR in the equivalent baseband. Here, the phase information is still in the bandpass region.
- For the discrete fourier transform DFT (and also for the ifft):
 - for each sample point the bandwidth increases by f_r
- This would result in

$$B_{actual} = N \cdot f_r = 5001 \cdot 10 \text{ MHz} = 50.010 \text{ GHz}$$
- So: $\mathbf{h = ifft(H(1:end-1))};$?
 (Still **no** for reason 2)

Deriving the CIR – 2 –

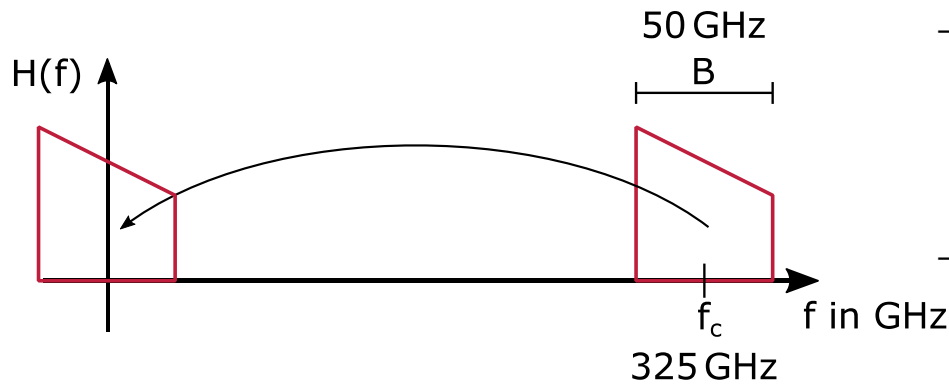

- Transforming the spectrum to the equivalent baseband means:

$$H_{bandpass}(f) = H_{baseband}(f - f_c)$$

- Moving by f_c in Frequency Domain equals Phaseshifting in Time Domain:

$$\exp(2j * \pi * f_c)$$

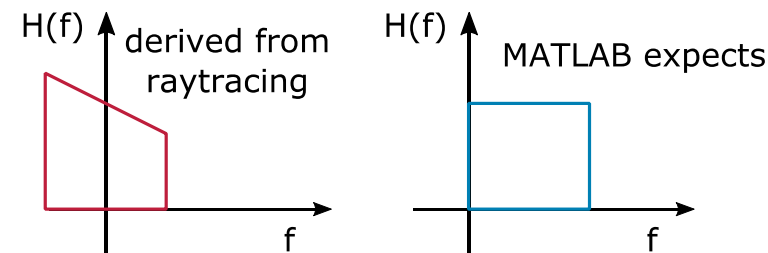

- So in conclusion:

$$h = \text{ifft}(H(1:\text{end}-1)) .* \exp(2j * \pi * f_c); ?$$

- Almost.
- Matlab expects a spectrum starting at zero not at $-\frac{B}{2}$ (this depends on implementation of the ifft!):

$$h = \text{ifft}(\text{ifftshift}(H(1:\text{end}-1))).* \exp(-2j * \pi * f_c);$$

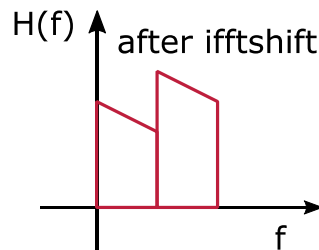

Deriving the CIR – 3 –

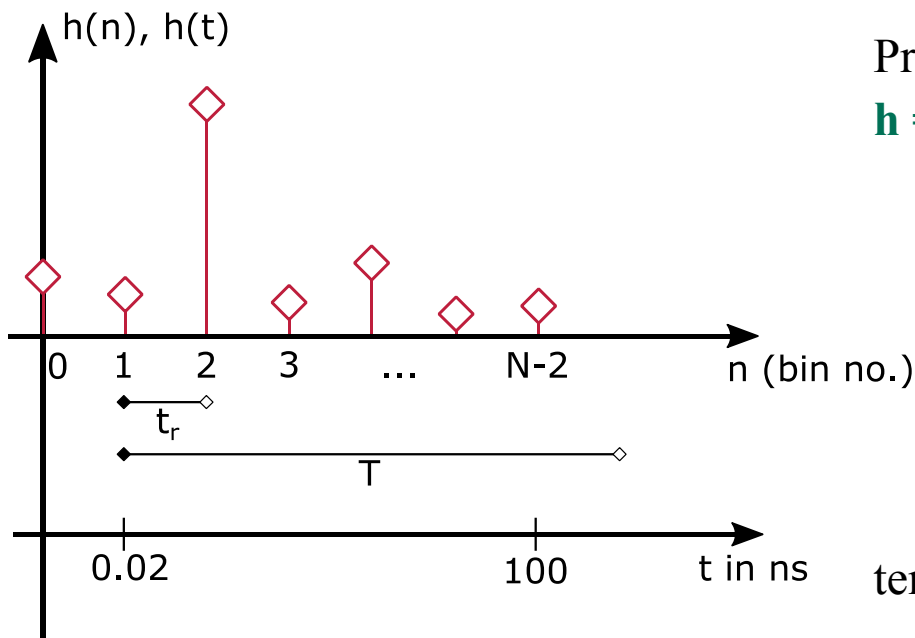

Properties of the CIR derived by:

$\mathbf{h} = \text{ifft}(\text{ifftshift}(\mathbf{H}(1:\text{end}-1))). * \exp(-2j * \pi * f_c);$

temporal resolution $t_R = \frac{1}{B} = \frac{1}{50 \cdot 10^6} = 0.02 \text{ ns}$

time axis: $t = n \cdot t_R; n = 0, 1, \dots, N - 2$

duration $T = (N - 2) \cdot t_R = \frac{1}{f_r} = 100 \text{ ns}$

Outline

1. Deriving the Channel Impulse Response
in the equivalent baseband region
from the broadband Channel Transfer Function
for link-level simulations
2. **“Synchronizing” the Channel Impulse Response
(CIR from broadband CTF does not include
the synchronization a receiver performs)**
3. Summary
4. Reference

“Synchronizing” the CIR – 1 –

- Raytracing determines the phase for a certain frequency in the CTF from the distance (l_{path}) between the transmitter and receiver and the wave length.
- The phase of the peak (corresponding to the used transmission path) in the impulse response will have an arbitrary phase corresponding to the distance.
- But the receiver has to synchronize to the received signal (to the symbol and to the carrier frequency).
- If a link-level simulation has to be performed without mechanisms for synchronization (e.g. like pilot signals, etc) the impulse of the transmission path can be synchronized to the previous or the next bin in the CIR as explained in the following.

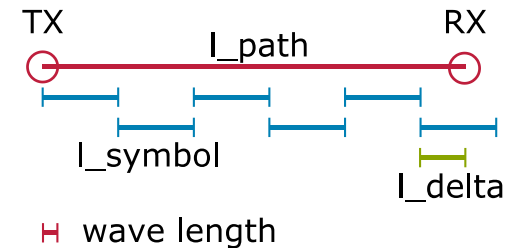

“Synchronizing” the CIR – 2 –

- The bandwidth determines the max. symbol rate to be transmitted:

$$R = 1/B = 1/T_{symbol}$$

- Each symbol has a length of $l_{symbol} = T_{symbol} \cdot c$
(with c : speed of light)

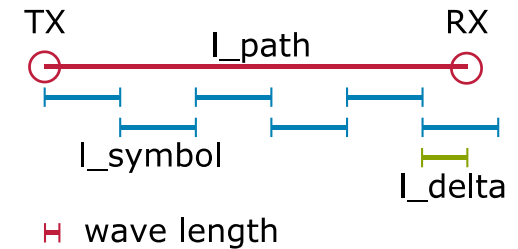

- The distance l_{path} can be expressed as:

$$l_{path} = m \cdot l_{symbol} + l_{delta} \text{ with } m \in 0, 1, 2, \dots$$

- This results in a delay of less than T_{symbol} in the CIR:

$$t_{delta} = l_{delta} \cdot c$$

- Delaying a signal by t_{delta} is achieved by multiplying the CTF with $e^{-j2\pi f t_{delta}}$
- For synchronization the CTF has to be multiplied with $e^{j2\pi f t_{delta}}$!

“Synchronizing” the CIR – 3 –

- To synchronize the CIR to the **previous bin** in the CIR in Matlab:

```
l_symbol= T_symbol * c;           e.g. l_symbol= 0.02 ns * 3e8 m/s= 6 mm
l_delta= mod(l_path, l_symbol);
t_delta= l_delta / c;
```

```
H= H .* exp(1j .* 2 .* pi .* f .* t_delta)    f is the frequency vector! E.g.:
                                              f= 300e9:f_resolution:350e9;
```

- To synchronize the CIR to the **next bin** in the CIR in Matlab:

```
l_symbol= T_symbol * c;
l_delta= mod(l_path, l_symbol) - l_symbol;
t_delta= l_delta / c;
```

```
H= H .* exp(1j .* 2 .* pi .* f .* t_delta)
```

- Please note that `mod(l_path, l_symbol)` results in the remaining distance and not a fractional factor of `l_symbol`! This depends on the implementation of the programming language used.

“Synchronizing” the CIR – 4 –

- Now the CIR is synchronized to the symbols.

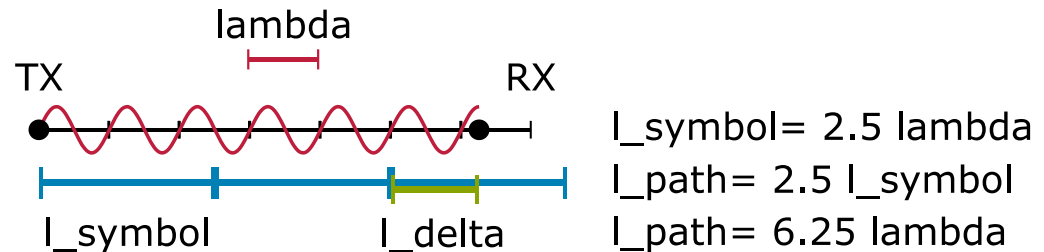

- Is the CIR also synchronized to the carrier frequency?

If it is, then the phase of the peak in the CIR is 0 deg.

- Answer: Maybe.

It depends on ...

- Path length
 - Bandwidth (l_{symbol})
 - Carrier Frequency (wave length λ)
 - Phase shifts from e.g. reflections (Non-Line-Of-Sight paths only)
- Synchronize: `cir = cir .* exp(-1j * phase_of_peak);`

Outline

1. Deriving the Channel Impulse Response
in the equivalent baseband region
from the broadband Channel Transfer Function
for link-level simulations
2. “Synchronizing” the Channel Impulse Response
(CIR from broadband CTF does not include
the synchronization a receiver performs)
3. **Summary**
4. Reference

Summary

- The CIR can be derived by
 1. Correctly performing the Inverse Fourier Transform of the CTF.

- To counter the influence of “leakage” – resulting from the ifft – it is advisable to set each bin in the CIR, which is e.g. 30 dB weaker than the dominant path, to zero.

- For link-level simulations without means for synchronization an artificially synchronized CIR can be derived by
 1. Synchronize to the Symbol (done in the CTF)
 2. Inverse Fourier Transform
 3. Turn the phase of the CIR to synchronize to the carrier frequency
 4. Set each bin in the CIR to zero which is e.g. 30 dB weaker than the dominant path.

Outline

1. Deriving the Channel Impulse Response
in the equivalent baseband region
from the broadband Channel Transfer Function
for link-level simulations
2. “Synchronizing” the Channel Impulse Response
(CIR from broadband CTF does not include
the synchronization a receiver performs)
3. Summary
4. **Reference**

Reference

- The derivation of the channel impulse response from the bandpass region to the equivalent baseband region is also explained in Michael Hiebel: “Grundlagen der vektoriellen Netzwerkanalyse”, Rohde&Schwarz, München 2007.
- The author has not had access to the English version of this book but expects that the derivation of the channel impulse response is also explained in Michael Hiebel: “Fundamentals of Vector Network Analysis”, Rohde&Schwarz, München 2011.

Danke für Ihre Aufmerksamkeit!
(Thank you for paying attention!)

Dipl.-Ing. Sebastian Rey
rey@ifn.ing.tu-bs.de