

Project: IEEE P802.15 Working Group for Wireless Personal Area Networks (WPANs)

Submission Title: [PHY OFDM Formats and Dimming Compatible Reversed Polarity Approach]

Date Submitted: [10, January, 2016]

Source: [Hany Elgala (University at Albany SUNY) and Thomas Little (Boston University)]
Address [1400 Washington Ave, Albany, NY 12222 and 8 Saint Mary's St. Boston MA 02215]
Voice:[617-353-9877], FAX: [617-353-6440], E-Mail:[tdcl@bu.edu, helgala@albany.edu]

Re: [09-Nov-2015 ET, 883, PHY Model for OFDM Intensity Modulation Incorporating PWM]

Abstract: [This is a PHY protocol for achieving OFDM intensity modulation with wide-range dimming through PWM while insuring full dynamic-range utilization and data rate consistency.]

Purpose: [We seek to include the proposed technique in the revised standard in order to enable dimming under an OFDM modulation technique (any optical OFDM format) when lights or lighting are used to deliver visible light communications (VLC).]

Notice: This document has been prepared to assist the IEEE P802.15. It is offered as a basis for discussion and is not binding on the contributing individual(s) or organization(s). The material in this document is subject to change in form and content after further study. The contributor(s) reserve(s) the right to add, amend or withdraw material contained herein.

Release: The contributor acknowledges and accepts that this contribution becomes the property of IEEE and may be made publicly available by P802.15.

Motivation

- Technical Considerations Document September, 2015 IEEE P802.15-15-0293-03-007a
- 4. Optical Wireless Communication Optical Wireless Communication (OWC) is a wireless communication method using optical wavelengths. OWC can be classified into:
 - A. Image Sensor Communications which enables optical wireless communications using an image sensor as a receiver.
 - B. High Rate PD Communications which is high-speed, bidirectional, networked and mobile wireless communications using light with a high speed photodiode receiver.
 - C. Low Rate PD Communications which is wireless light ID system using various LEDs with a low speed photodiode receiver.
- 4.4.6 Dimming Control The standard will support dimming control for application A1, A2, A3, A4 and A7.
- 4.5.4 Dimming Control The Standard will support dimming control for application B1-B3.
- 4.6.6 Dimming Control The standard will support dimming control for all of applications

A1 Offline to Online Marketing¹/Public Information System [2, 3, 5, 6, 7]

A2 IoT² (M2M/D2D³/ Internet of Light (IoL)) [2, 3, 9, 10, 11]

A3 LBS⁴ / Indoor Positioning [2, 5, 10, 17]

A4 Vehicular Communication [2, 7]

A5 Underwater Communication [8]

A6 Power Consumption Control [4]

A7 Vehicular Positioning [2]

A8 Seaside Communication [19]

A9 LED based Tag application [5, 8]

A10 Point-to-(multi)point / relay⁵ communication [8, 9, 5]

A11 Digital signage [8, 5, 17]

C1 Underwater/Seaside Communication [8]

C2 Point-to-(multi)point / communication [5, 8, 9]

C3 Digital signage [5, 8, 17]

C4 D2D/IoT [5, 9]

C5 LOS Authentication [5, 17]

C6 Identification based service [20, 21]

B1 Indoor Office/Home Applications: (Conference Rooms, General Offices, Shopping Centres, Airports, Railways, Hospitals, Museums, Aircraft Cabins, Libraries etc.)

B2 Data Center / Industrial Establishments, Secure Wireless (Personalized Manufacturing Cells, Factories, Hangers, etc.)

B3 Vehicular Communications (Vehicle-to-vehicle, Vehicle-to-Infrastructure)

B4 Wireless Backhaul (Small Cell Backhaul, Surveillance Backhaul, LAN Bridging)

Dimming with Pulsed Modulation (two-level dimming)

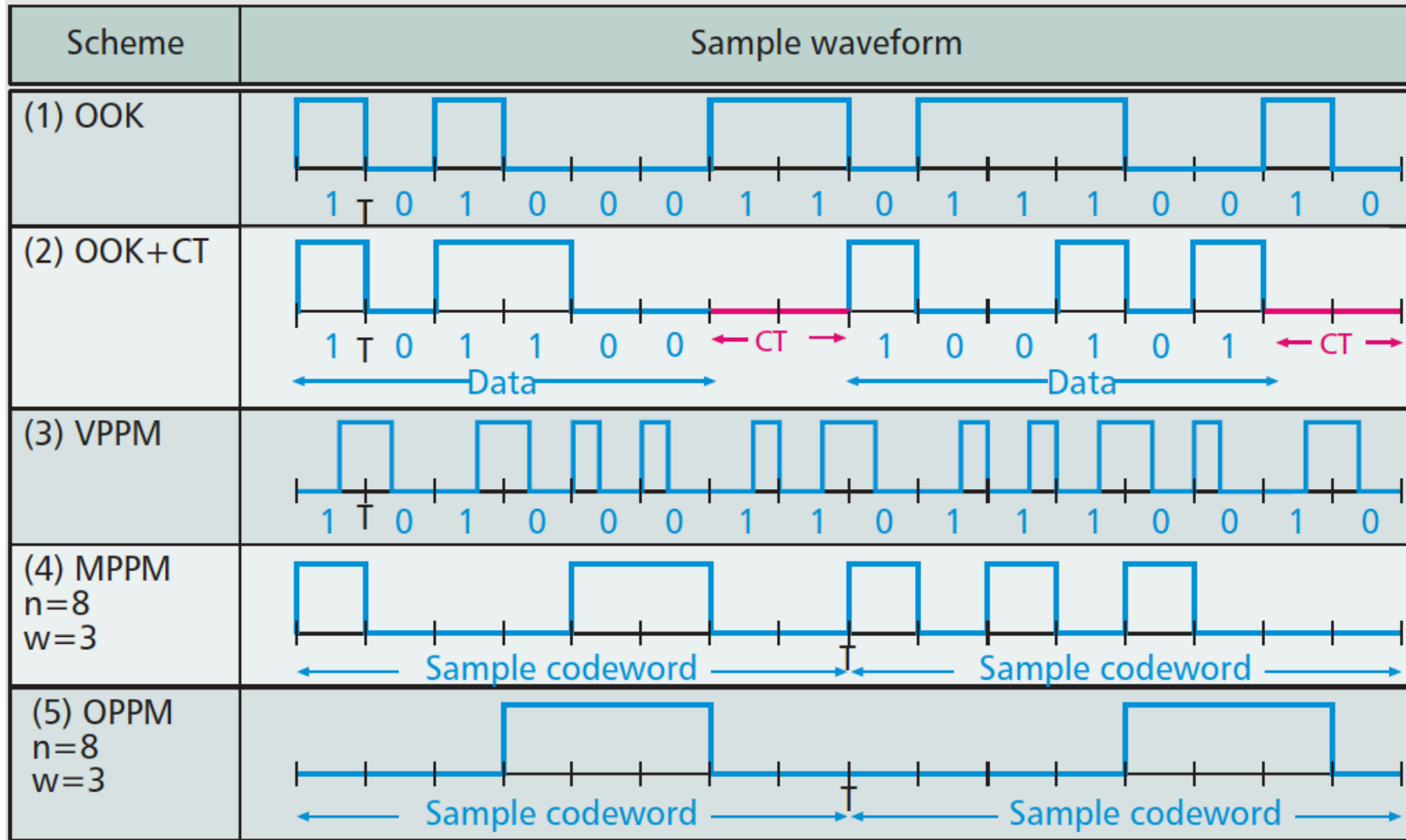

- Gancarz, John, Hany Elgala, and Thomas DC Little. "Impact of lighting requirements on VLC systems." Communications Magazine, IEEE 51.12 (2013): 34-41.

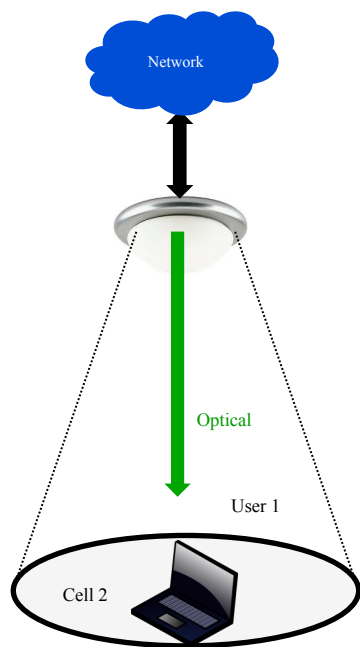

- Primarily downlink model
- While supporting (our use case):
 1. Illumination functionality
 2. High quality lighting
 3. High-speed VLC downlink using OFDM

B1: Operating Scenario

Structure

- Communication and illumination constraints with direct IM-DD OFDM
- The communication capacity of OFDM needs to be reduced proportional to intensity
 - Reverse polarity optical OFDM (RPO-OFDM): Simulation and Experimental Results
- It is not only about the spectral efficiency when choosing the best optical OFDM format
 - Spectral and Energy Efficient OFDM (SEE-OFDM)
 - Polar-OFDM (P-OFDM)
- Conclusion

Structure

- Communication and illumination constraints with direct IM-DD OFDM
- The communication capacity of OFDM needs to be reduced proportional to intensity
 - Reverse polarity optical OFDM (RPO-OFDM): Simulation and Experimental Results
- It is not only about the spectral efficiency when choosing the best optical OFDM format
 - Spectral and Energy Efficient OFDM (SEE-OFDM)
 - Polar-OFDM (P-OFDM)
- Conclusion

OFDM Formats

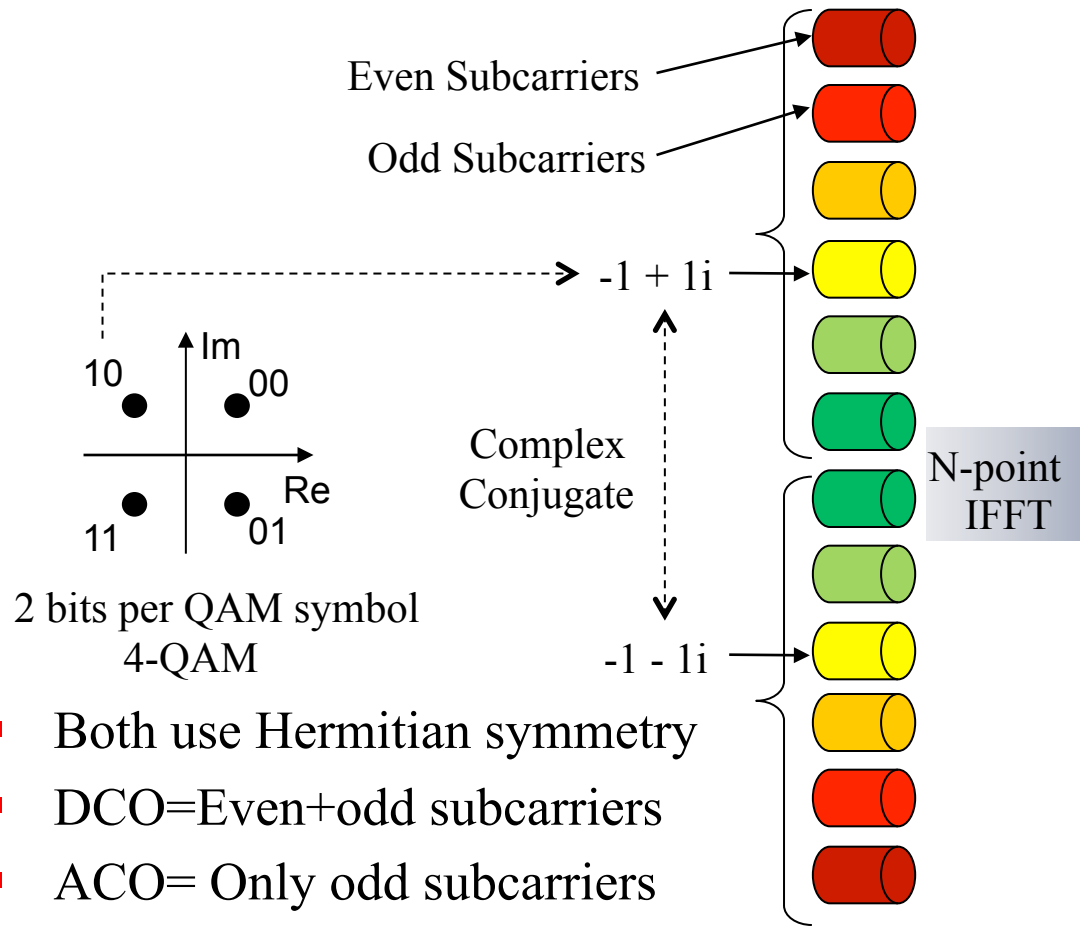

Constraint:

- Intensity modulation; real signal

RF-OFDM symbol

$$\pm(\text{Re}) \pm j(\text{Img})$$

DCO-OFDM symbol

Re +
Re -

ACO-OFDM symbol

Re _A +	Re _B +
Re _B -	Re _A -

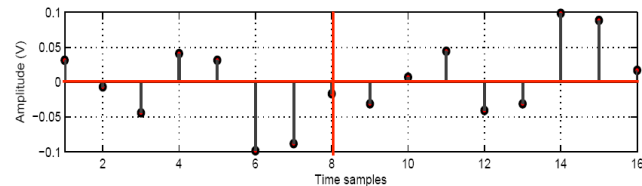

- Both use Hermitian symmetry
- DCO=Even+odd subcarriers
- ACO= Only odd subcarriers

QAM: quadrature amplitude modulation
 IFFT: inverse fast Fourier transform
 DC biased optical OFDM (DCO-OFDM)
 Asymmetric clipped optical OFDM (ACO-OFDM)

OFDM Formats

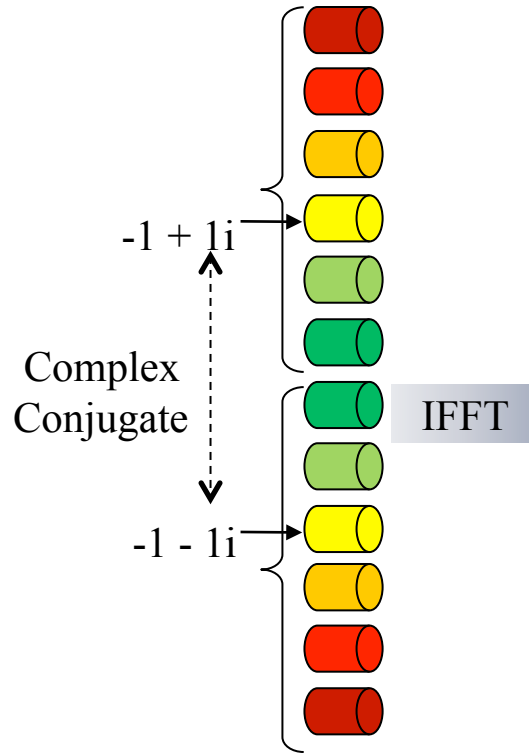

Other unipolar formats:
HACO, ASCO, eU-OFDM, SEE-OFDM,
P-OFDM...etc

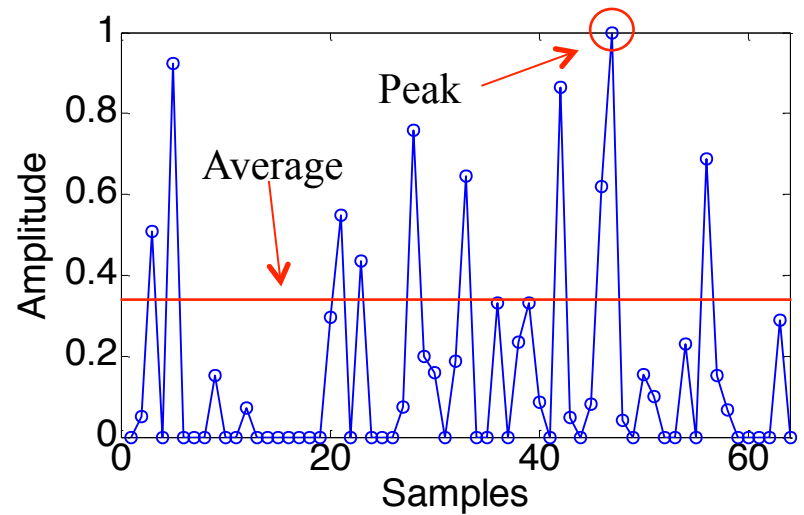
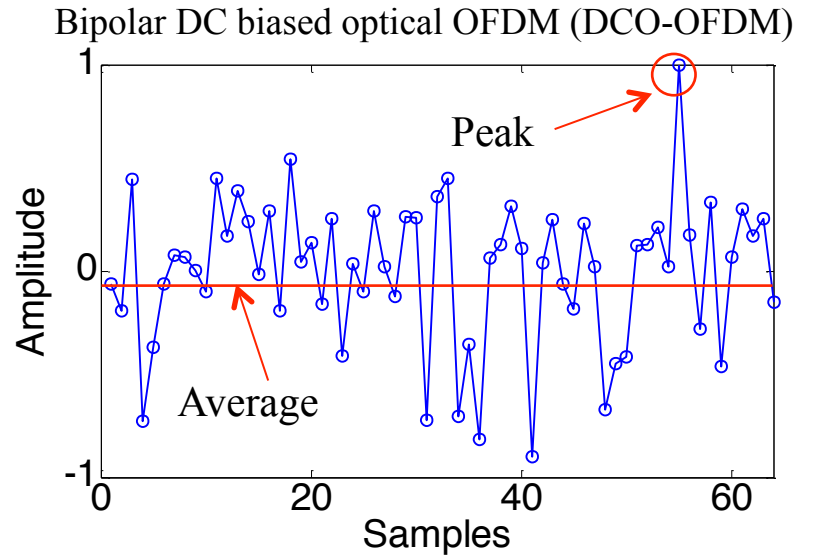

Unipolar Asymmetric clipped optical OFDM (ACO-OFDM)

More Constraints

- Positive optical power; DCO is biased and ACO is clipped
- PAPR; OFDM signal has high PAPR
- Dynamic range; clipping due to LEDs
- Average power; dimming functionality

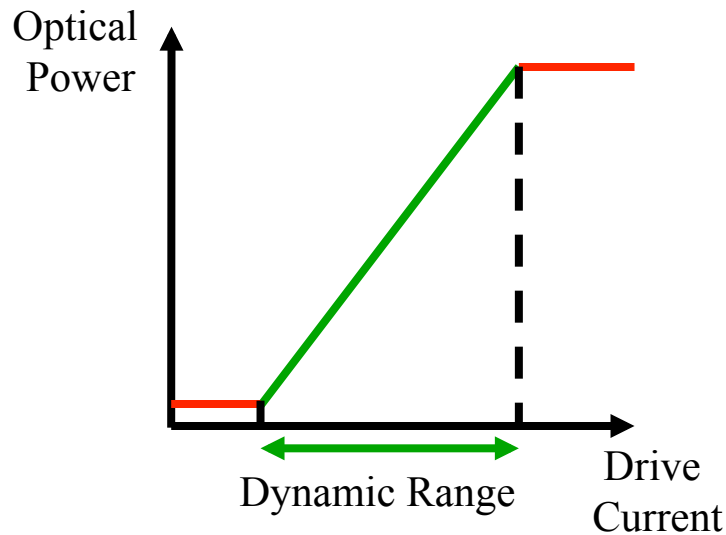

Peak-to-average power ratio (PAPR)

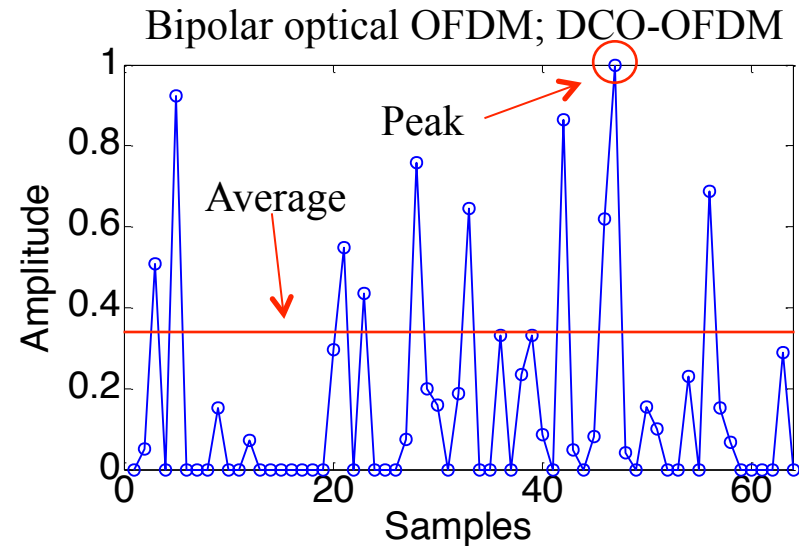
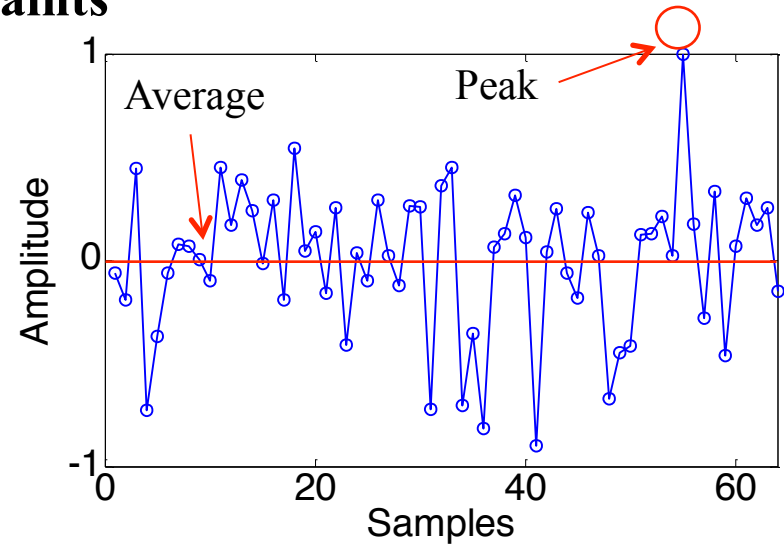

Unipolar optical OFDM; ACO-OFDM

Structure

- Communication and illumination constraints with direct IM-DD OFDM
- The communication capacity of OFDM needs to be reduced proportional to intensity
 - Reverse polarity optical OFDM (RPO-OFDM): Simulation and Experimental Results
- It is not only about the spectral efficiency when choosing the best optical OFDM format
 - Spectral and Energy Efficient OFDM (SEE-OFDM)
 - Polar-OFDM (P-OFDM)
- Conclusion

- RPO-OFDM technique,
 - Performance does not need to be reduced proportional to intensity
 - Implementation using any optical OFDM formats
 - Dimming can be linearly adjusted
 - Bit-error performance is sustained over a large fraction of the dimming range
 - A practical approach; capacity is not limited by the PWM frequency

Dimming with OFDM

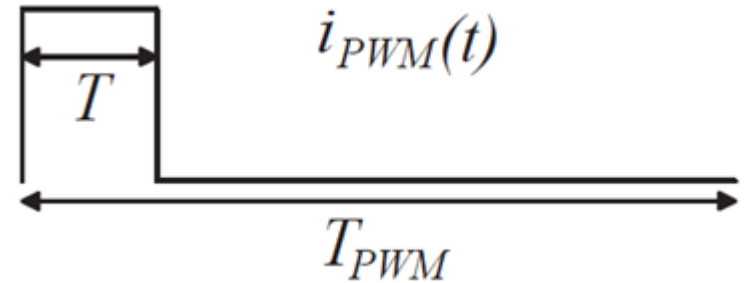
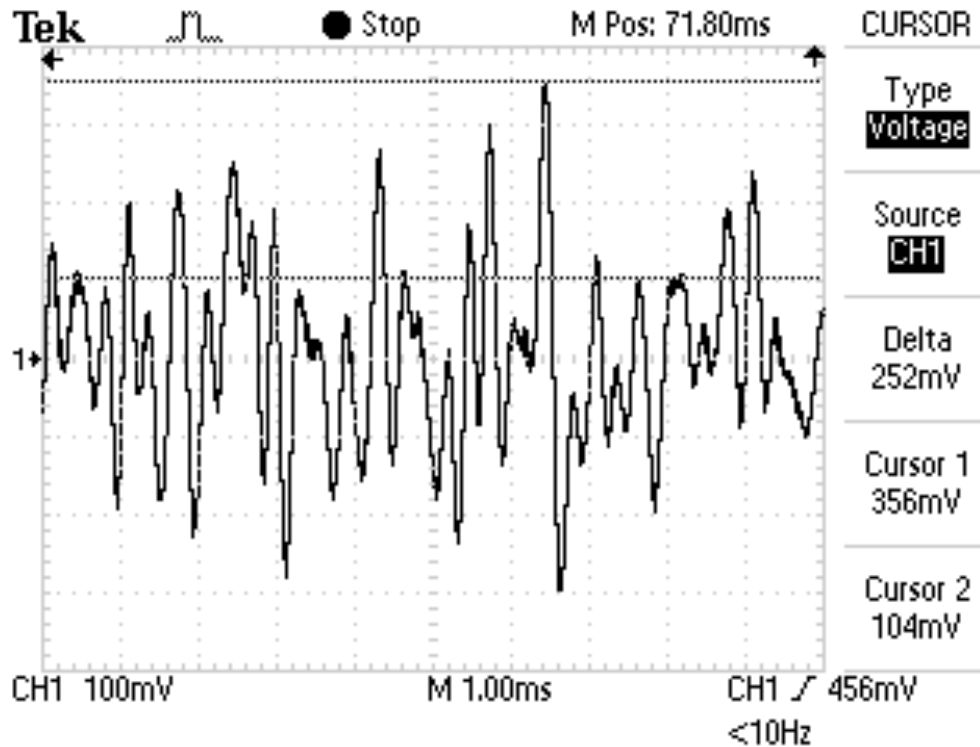

$$D = T / T_{PWM}$$

Existing solutions:

- Direct superposition on the PWM only during the ON-period
- OFDM signal sampling using the PWM signal
- Average power reduction per OFDM symbol

Pulse width modulation (PWM)

The idea!

For large number of sub-carriers, and according to the central limit theorem, the OFDM samples can be accurately modeled as a Gaussian random process with a zero mean value $\mu_x = 0$ and a variance σ_x^2 ; P_{signal} is equal to σ_x^2 for $\mu_x = 0$.

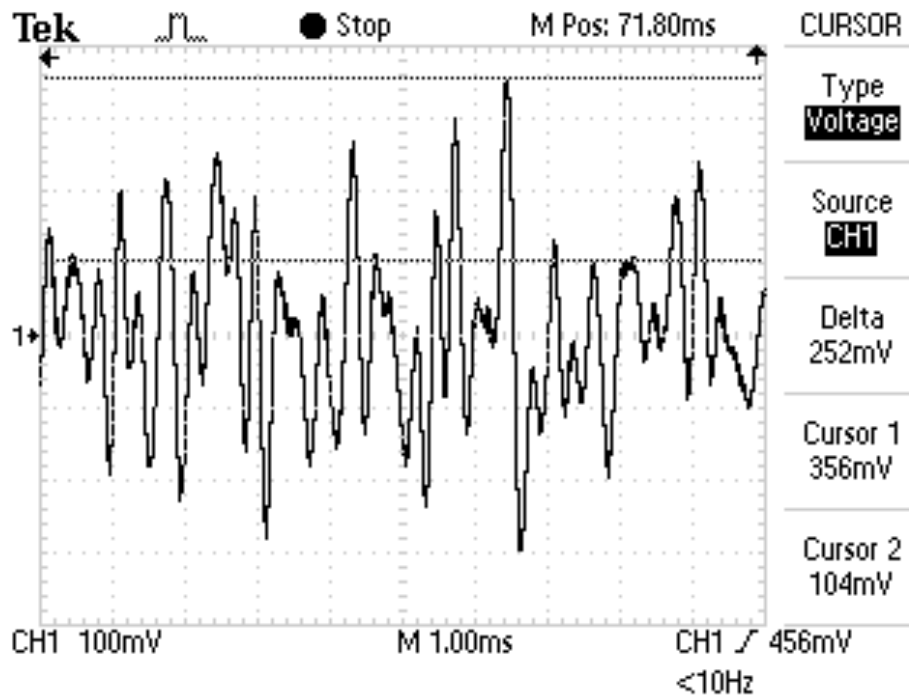

$$x_n = \frac{1}{\sqrt{N}} \sum_{k=0}^{N-1} X_k \exp(j \frac{2\pi}{N} nk)$$

$$\text{SNR} = P_{\text{signal}} / N_{\text{signal}}$$

Important Parameters

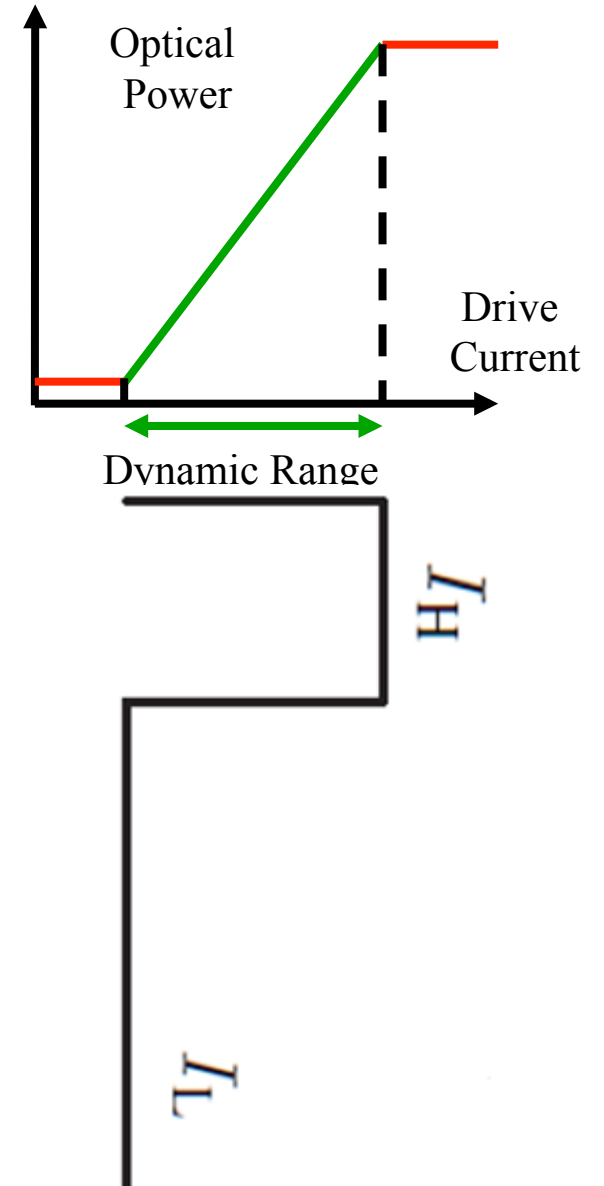
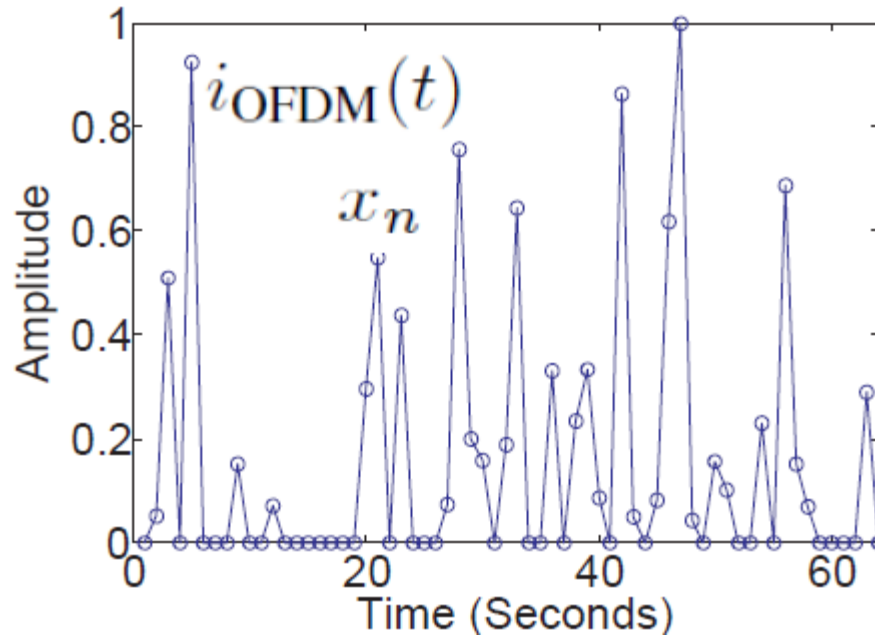

$$DR_{LED} = I_H - I_L$$

$$DR_{OFDM} = \max\{x[n]\} - \min\{x[n]\}$$

$$DR_{OFDM} \leq DR_{LED}$$

How to Generate a RPO-OFDM Signal?

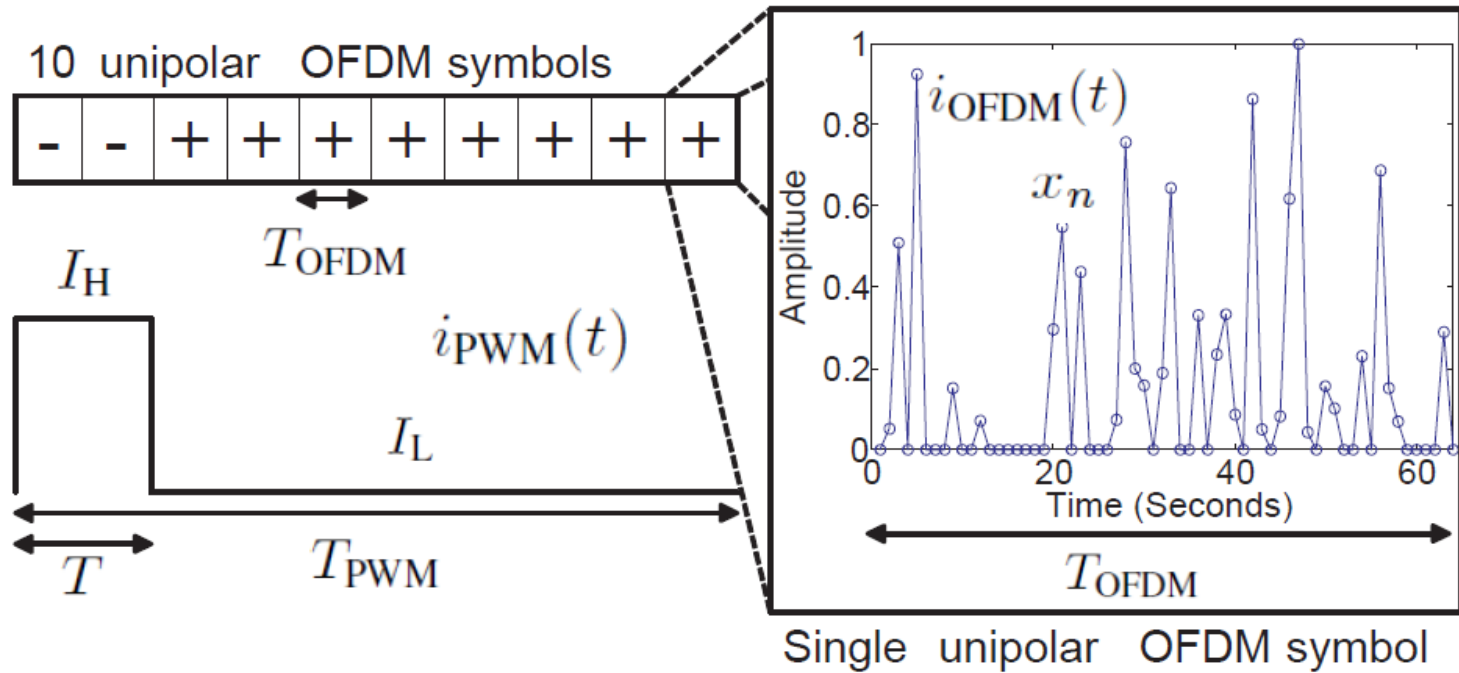

$$I_{SB} = D(I_H - \frac{mi}{N} \sum_{k=0}^{N-1} x_n) + (1 - D)(I_L + \frac{mj}{N} \sum_{k=0}^{N-1} x_n)$$

Time-Domain RPO-OFDM Signals

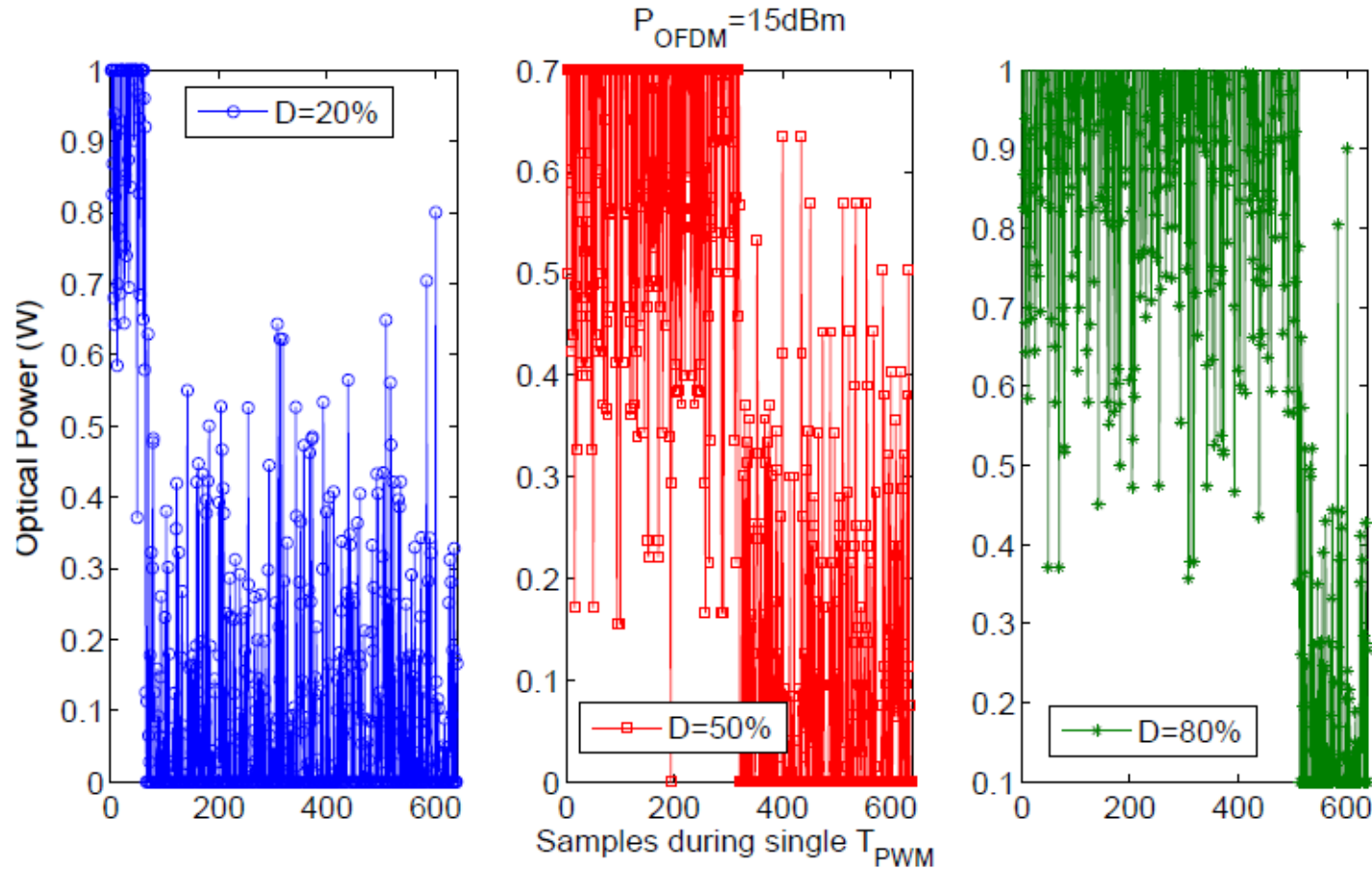

$$I_{\text{SB}} = D(I_H - \frac{mi}{N} \sum_{k=0}^{N-1} x_n) + (1 - D)(I_L + \frac{mj}{N} \sum_{k=0}^{N-1} x_n)$$

Simulations: Dimming vs. duty cycle

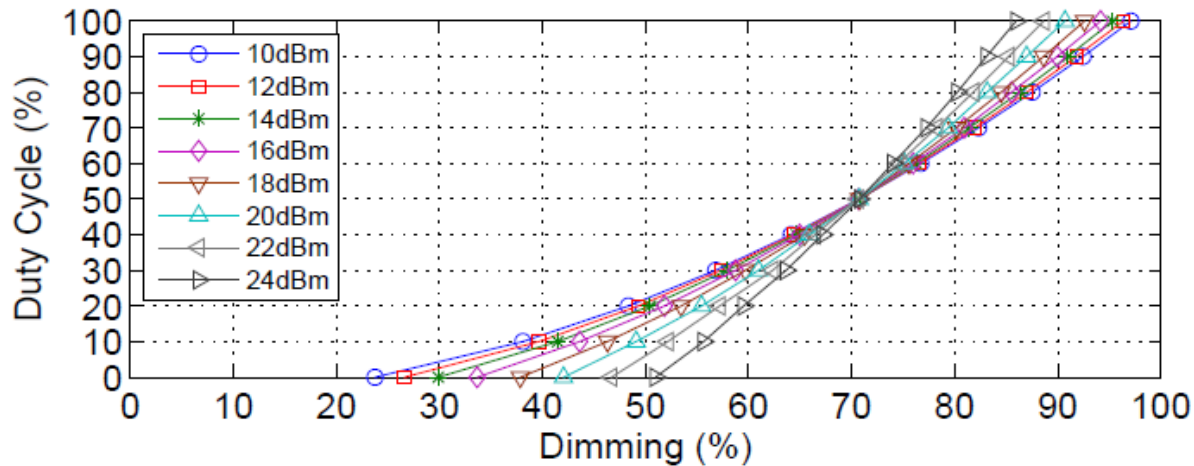
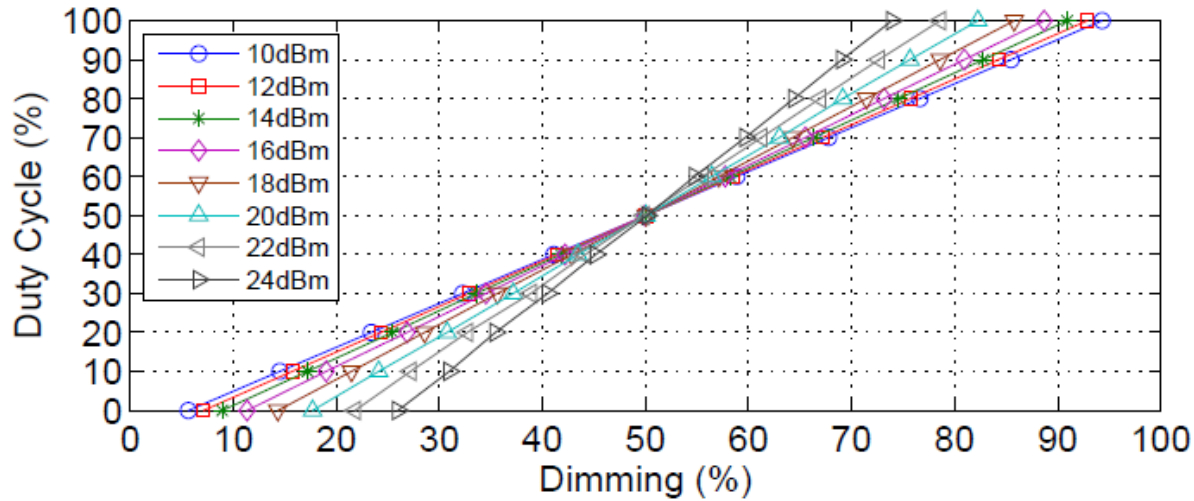

$$\text{Perceived Light}(\%) = 100 \cdot \sqrt{\frac{\text{Measured Light}(\%)}{100}}$$

Experimental Setup

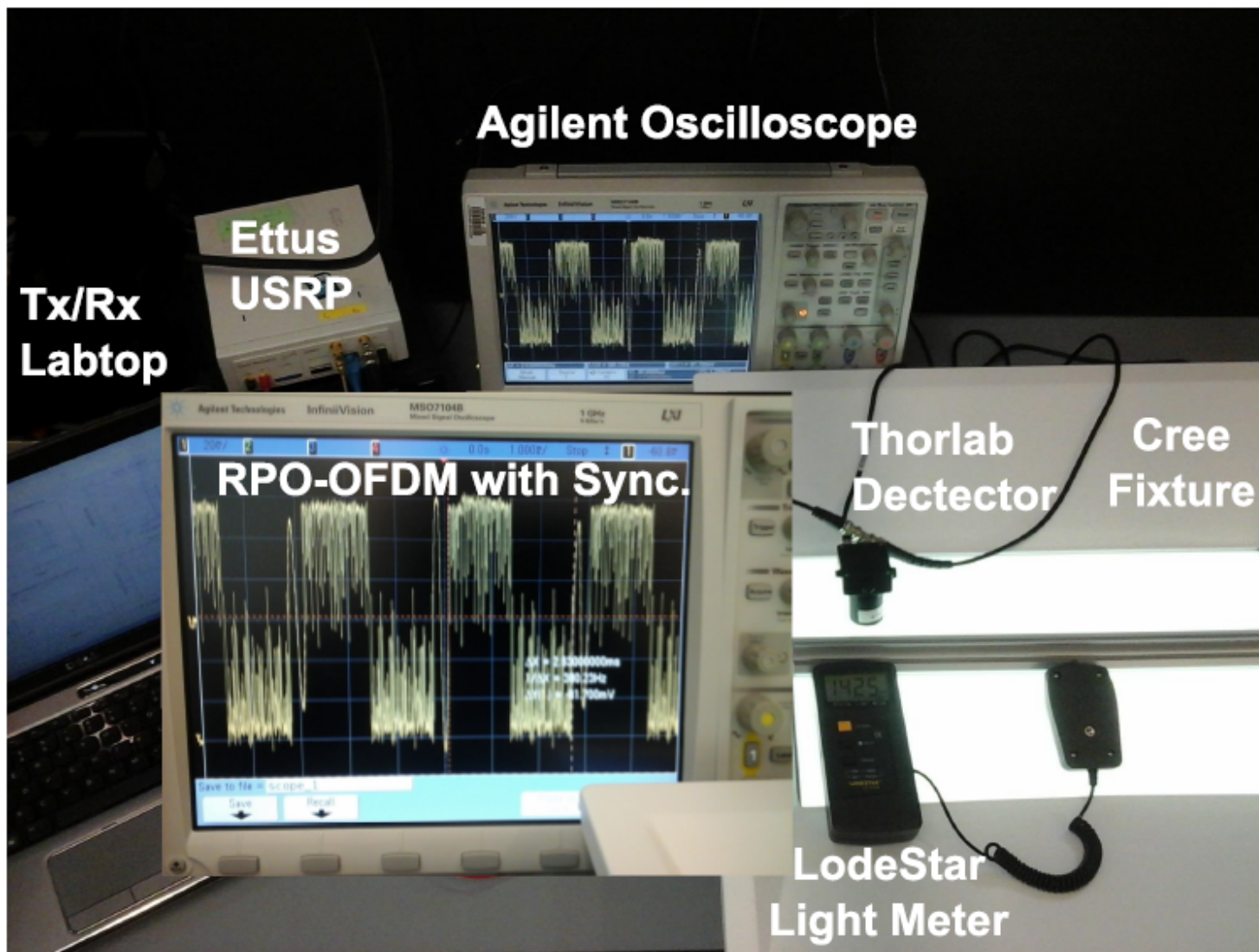

Experimental: Illuminance/dimming vs. duty cycle

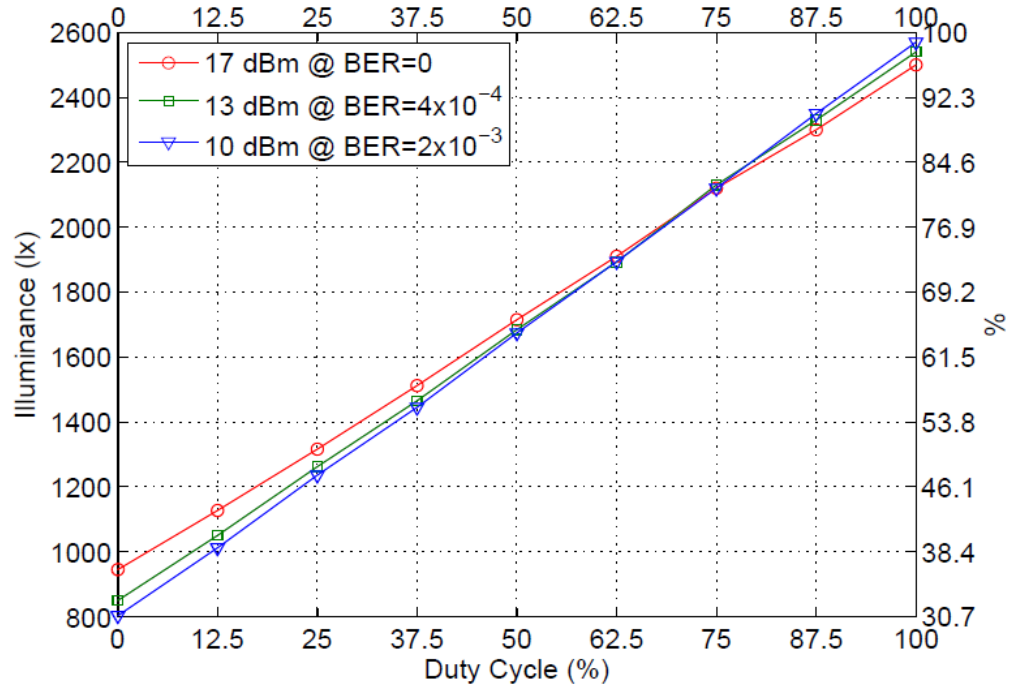
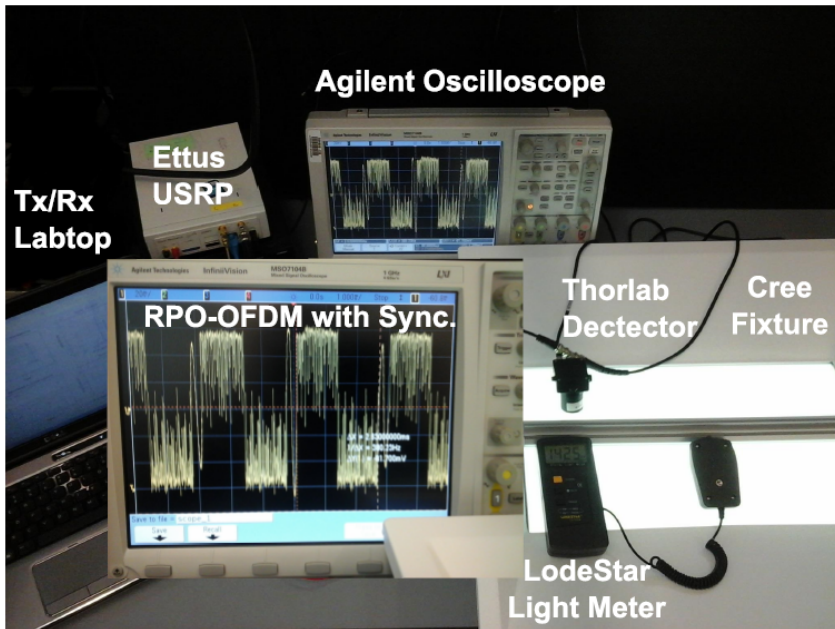

Experimental: Illuminance/dimming vs. duty cycle

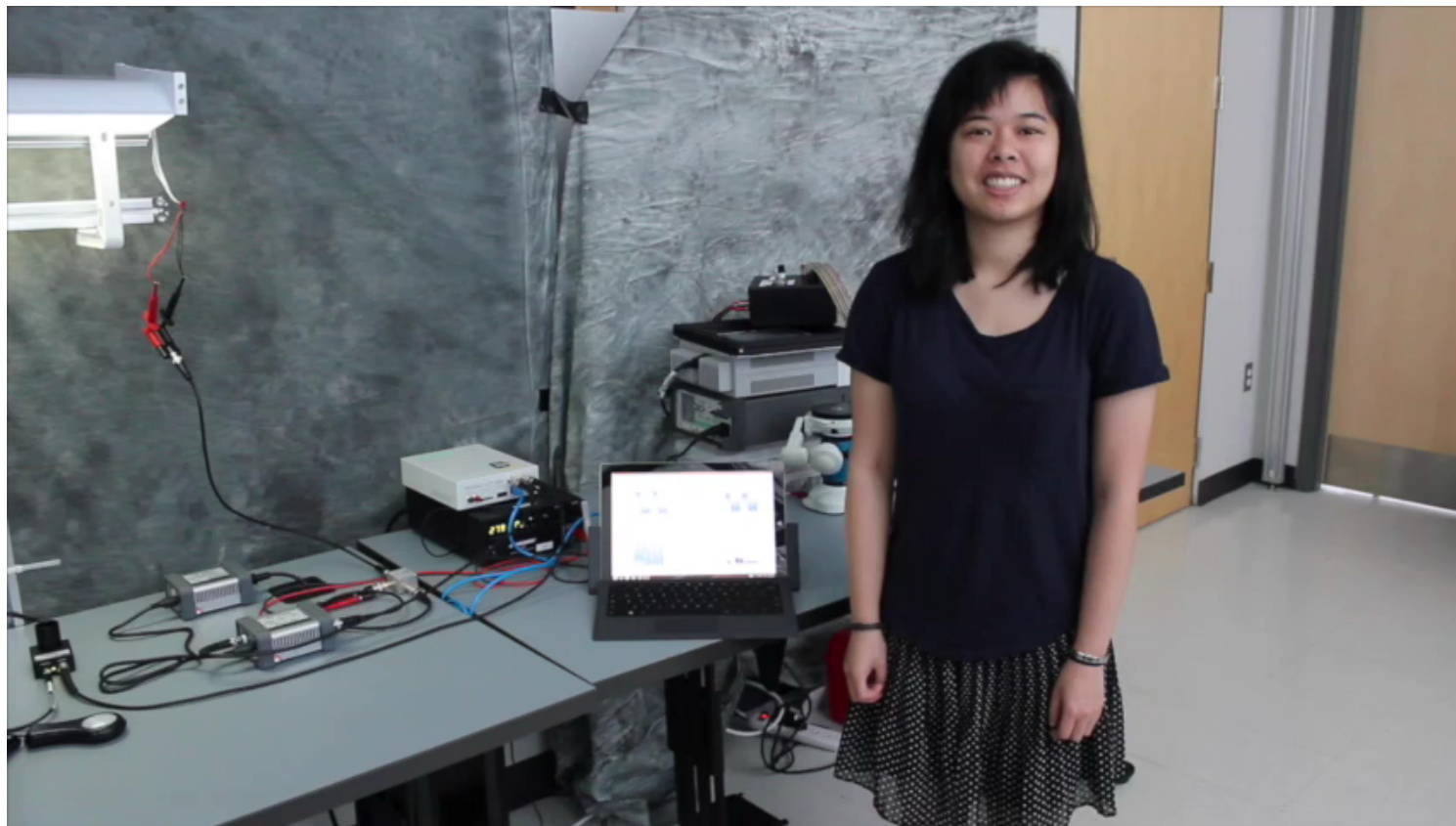

Experimental: Illuminance/dimming vs. duty cycle

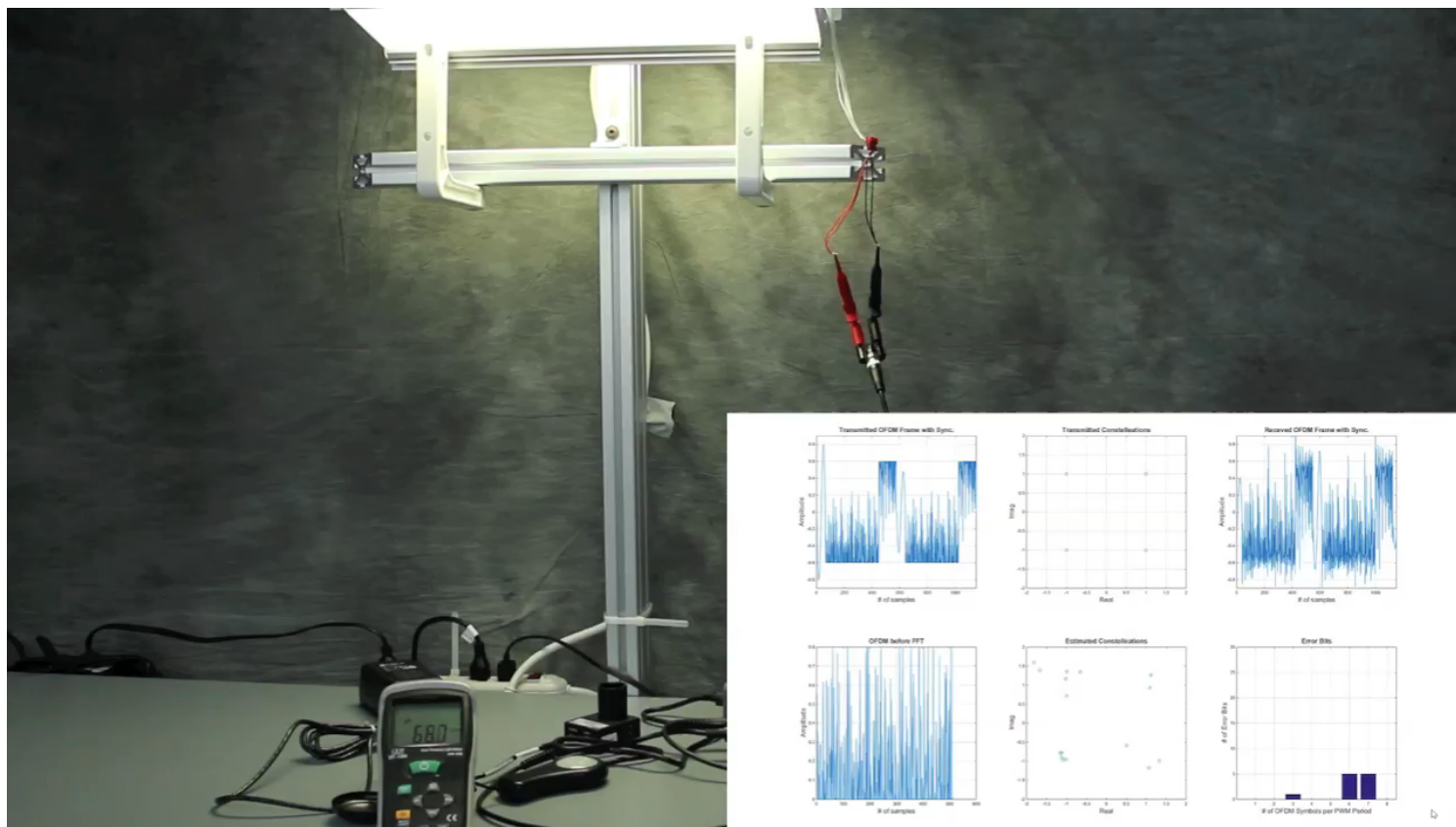

Home Scenario CRIs Simulations

- LED dynamic range 1.4
- AWGN -30 dBm
- Raw electrical SNR!

D	P(dBm)	SNR
1	17.8	47.8
2	23.6	53.6
3	23.7	53.6
4	20.8	50.8
5	19.5	49.5
6	21.3	51.3
7	19.8	49.8
8	20.2	50.2

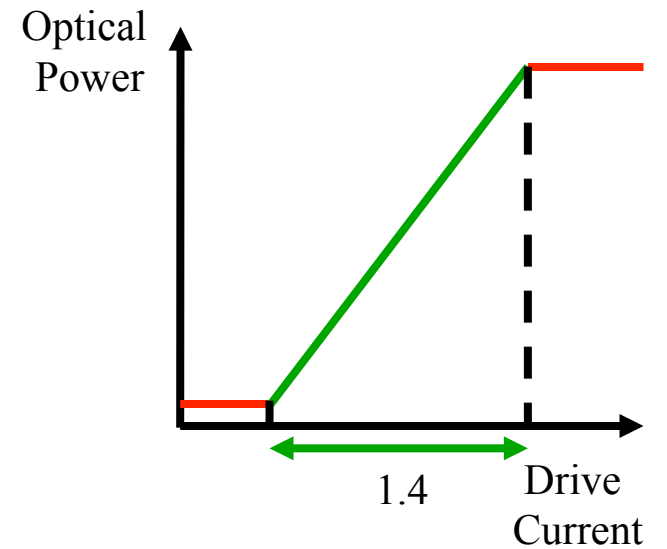
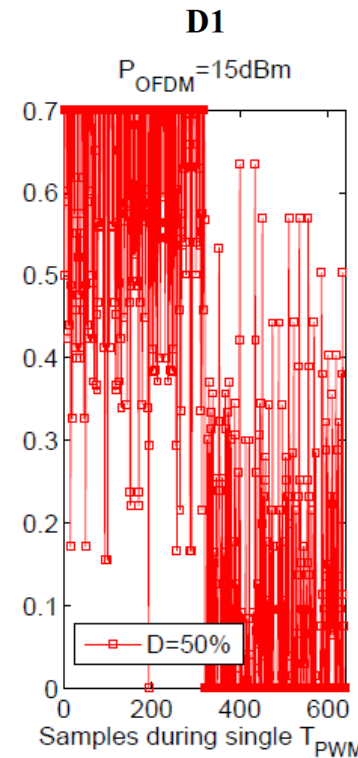
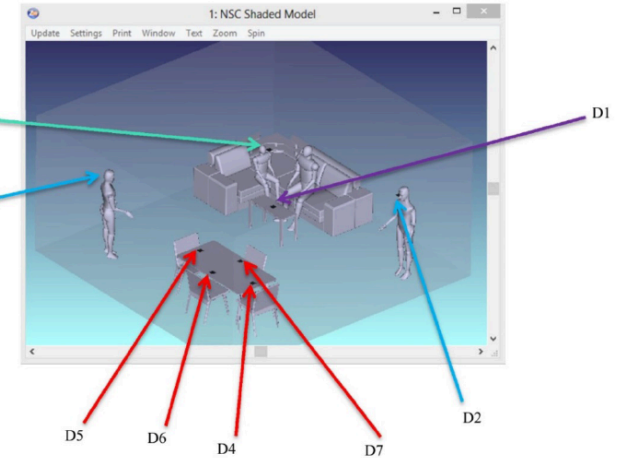
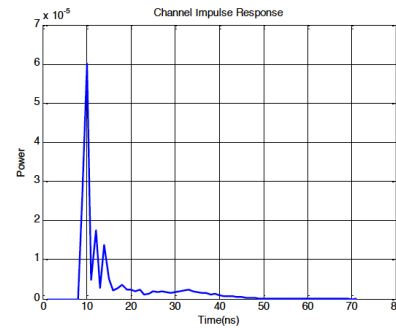

Home Scenario CRIs Simulations, Average vs Location:

- LED dynamic range 1.4

10 %

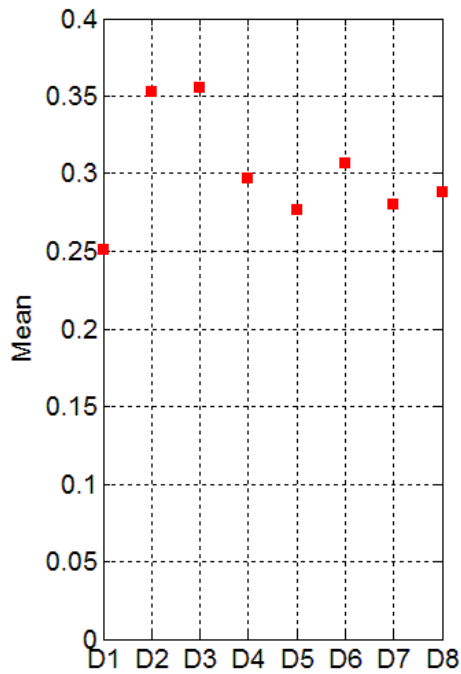

50 %

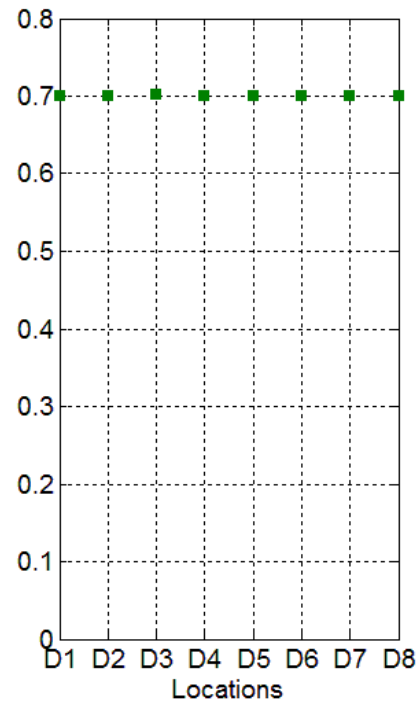

90 %

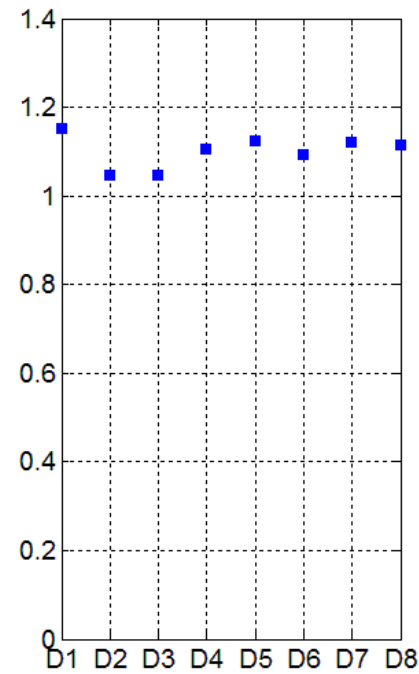





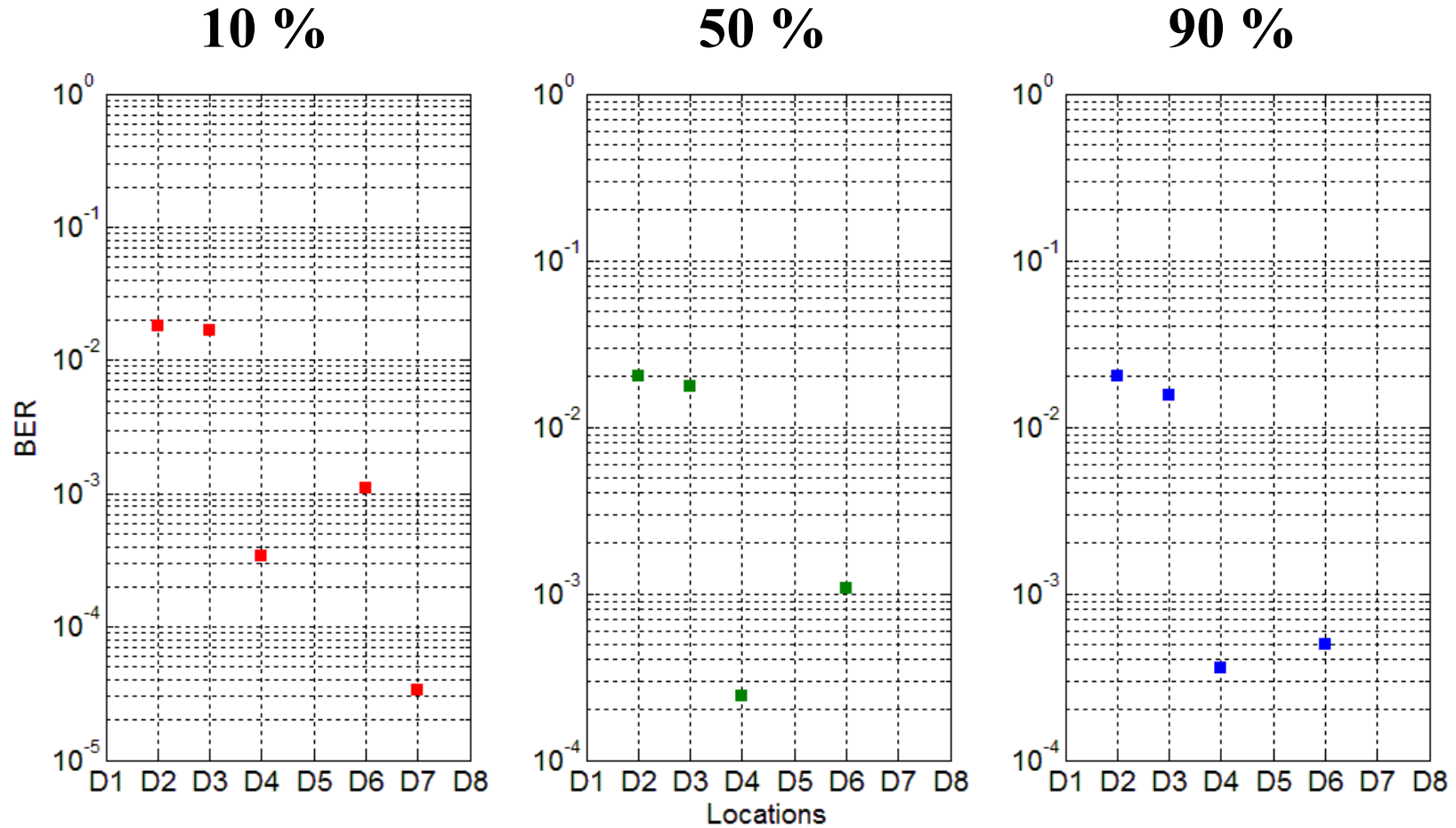







D	P(dBm)	SNR
1	17.8	47.8
2	23.6	53.6
3	23.7	53.6
4	20.8	50.8
5	19.5	49.5
6	21.3	51.3
7	19.8	49.8
8	20.2	50.2

Home Scenario CRIs Simulations, BER vs Location:



Whatever-OFDM

 Technische Universiteit Eindhoven University of Technology	 Technische Universität München	pulse-amplitude-modulated discrete multi-tone modulation (PAM-DMT) (2009)
		
 MONASH University Flip-OFDM (2011)	 THE UNIVERSITY of EDINBURGH Unipolar-OFDM (2012)	 University of South Australia Position Modulation-OFDM (2012)
 MONASH University Symmetrically clipped DC-biased optical (ADO)-OFDM (2011)	 PENNSTATE Hybrid asymmetrically clipped optical orthogonal frequency division multiplexing (HACO-OFDM) (2014)	 NJIT New Jersey's Science & Technology University Asymmetrically and symmetrically clipping optical (ASCO)-OFDM (2015)
 BOSTON UNIVERSITY Polar OFDM (P-OFDM) (2014)	 BOSTON UNIVERSITY Spectral & energy efficient OFDM (SEE-OFDM) (2014)	 THE UNIVERSITY of EDINBURGH Enhanced Unipolar-OFDM (eU-OFDM) (2014)

$$+ \text{RPO-OFDM} =$$

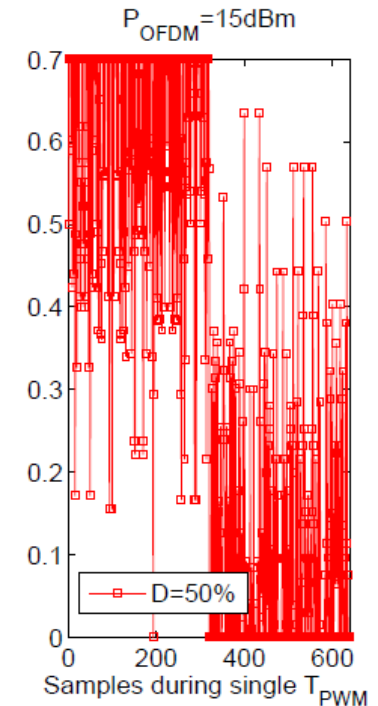

- Ali Mirvakili, Rahaim, Michael, Brandon, Valencia J Koomson, Hany Elgala and Thomas D. C. Little, " Wireless Access Test-bed through Visible Light and Dimming Compatible OFDM", the IEEE Wireless Communications and Networking Conference (WCNC 2015), March 09-12, 2015, New Orleans, LA, USA.
- Thomas D. C. Little and Hany Elgala, "Adaptation of OFDM under Visible Light Communications and Illumination Constraints", the Asilomar Conference on Signals, Systems, and Computers, November 2-5, 2014, Pacific Grove, California.
- Hany Elgala and Thomas D. C. Little, "Reverse polarity optical-OFDM (RPO-OFDM): dimming compatible OFDM for gigabit VLC links", OSA Optics Express, Vol. 21, Issue 20, pp. 24288-24299, October 2013.

Structure

- Communication and illumination constraints with direct IM-DD OFDM
- The communication capacity of OFDM needs to be reduced proportional to intensity
 - Reverse polarity optical OFDM (RPO-OFDM): Simulation and Experimental Results
- It is not only about the spectral efficiency when choosing the best optical OFDM format
 - Spectral and Energy Efficient OFDM (SEE-OFDM)
 - Polar-OFDM (P-OFDM)
- Conclusion

TX: SEE-OFDM

Challenge: The optical version of OFDM is not spectrally efficient

- Spectral and energy efficient OFDM (SEE-OFDM)
- Polar-OFDM (P-OFDM)

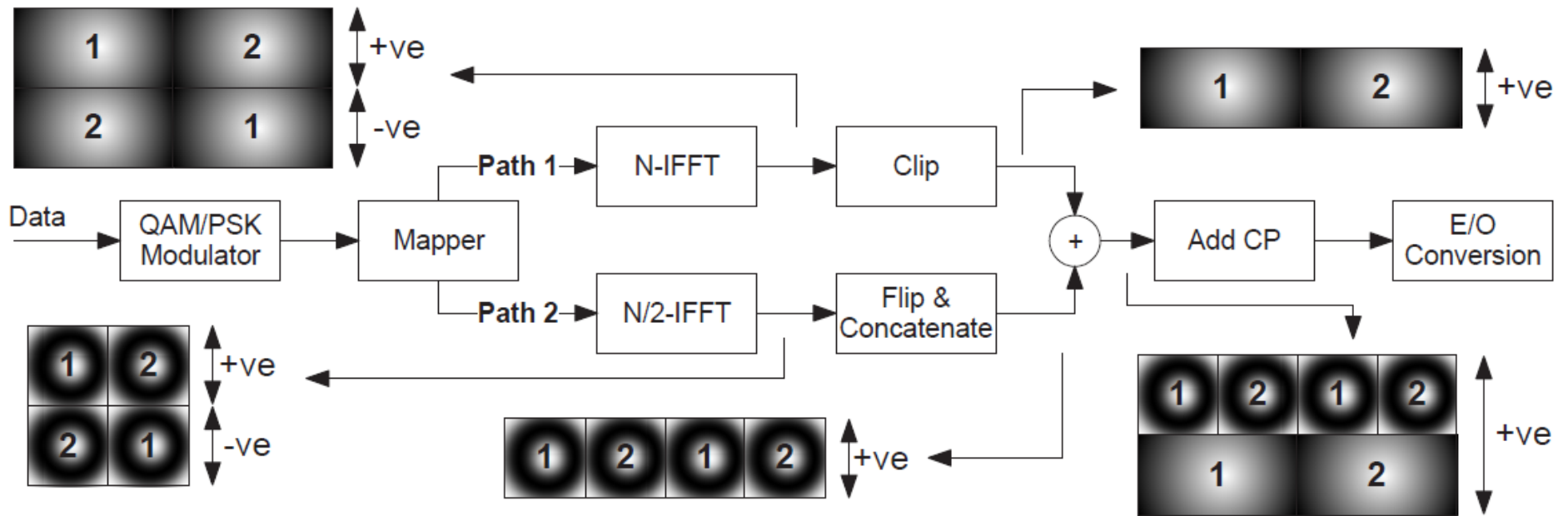

RX: SEE-OFDM

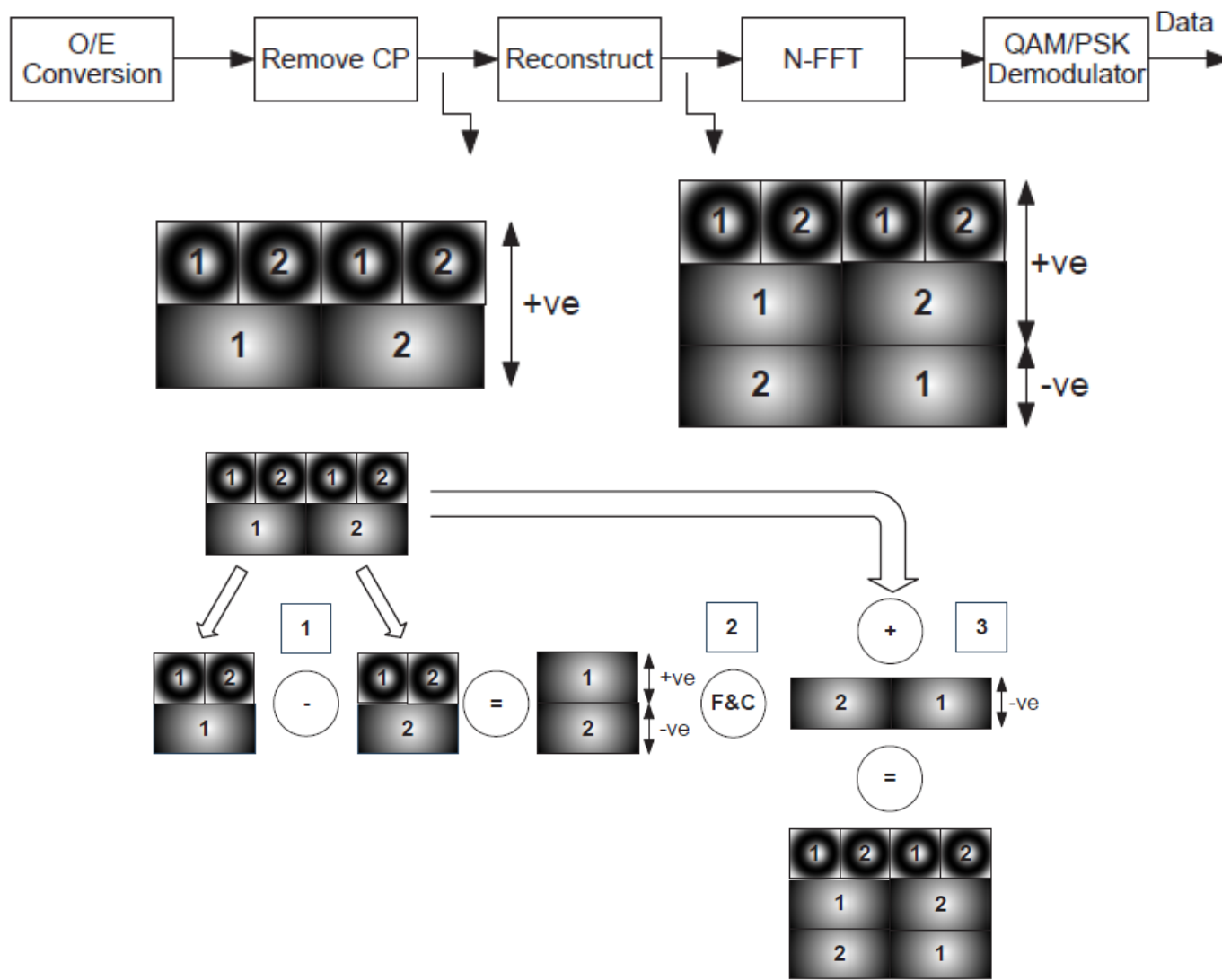

Effective data-rate

$$R_{\text{total}} = R_{\text{path 1}} + R_{\text{path 2}}$$

$$= \left(\frac{(N/4) + (N/8)}{N + N_{\text{CP}}} \right) B \log_2 M$$

$$R_{\text{total}} = R_{\text{path 1}} + R_{\text{path 2}} + R_{\text{path 3}}$$

$$= \left(\frac{(N/4) + (N/8) + (N/16)}{N + N_{\text{CP}}} \right) B \log_2 M$$

Path 3

Path 2

Path 1

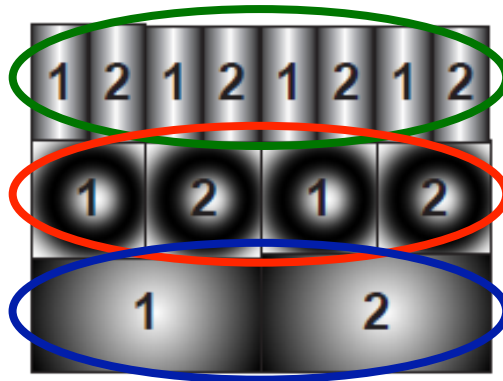

Before reconstruction

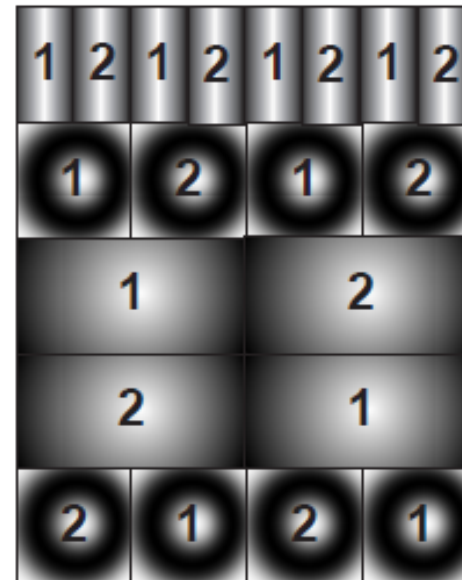

After reconstruction

The higher the QAM order the wider the gap

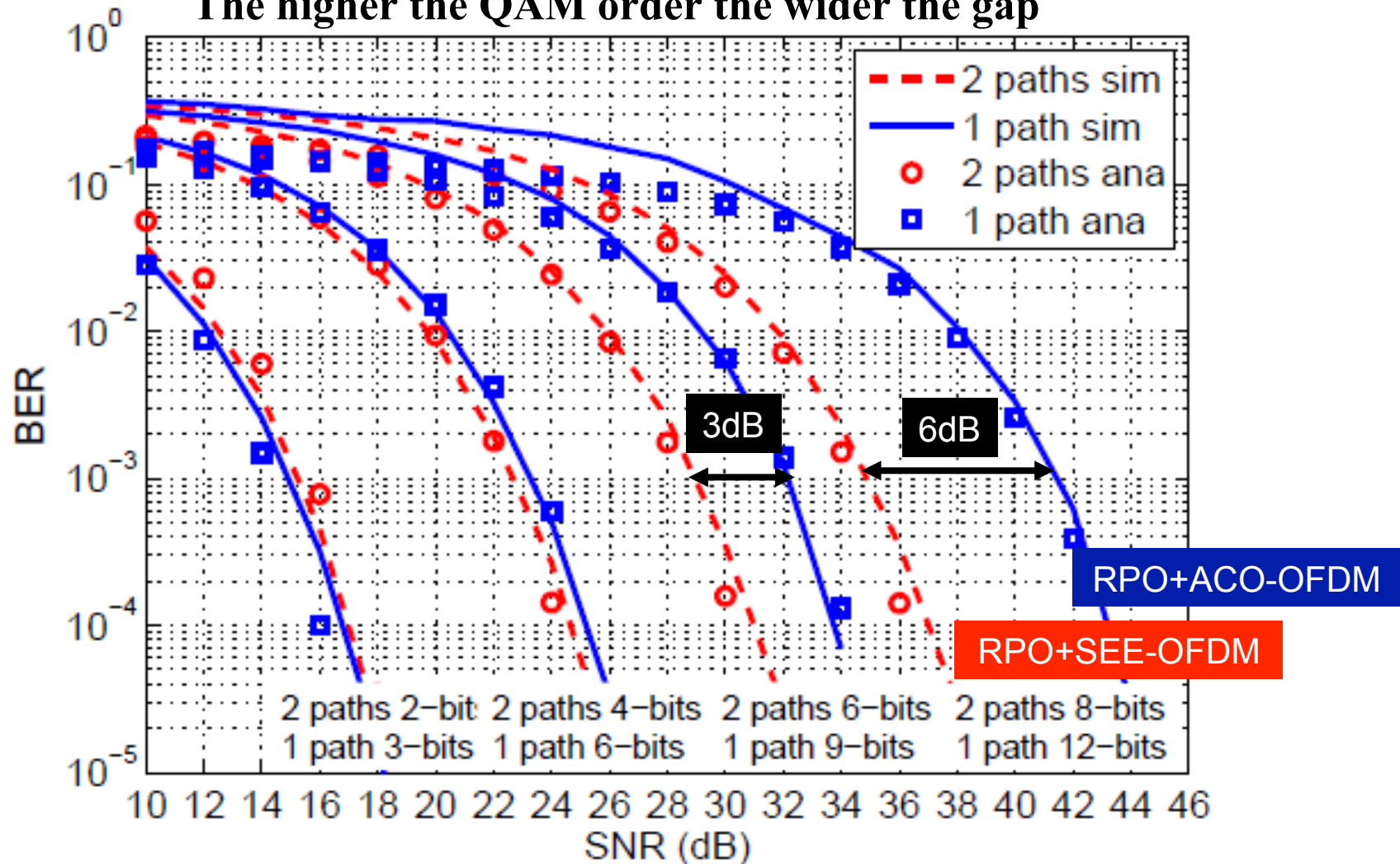

- H. Elgala and TDC Little, "SEE-OFDM: Spectral and Energy Efficient OFDM for Optical IM/DD Systems", the IEEE International Symposium on Personal, Indoor and Mobile Radio Communications (PIMRC 2014), September 2-5, 2014, Capital Hilton, Washington DC.

More paths means less PAPR, however...

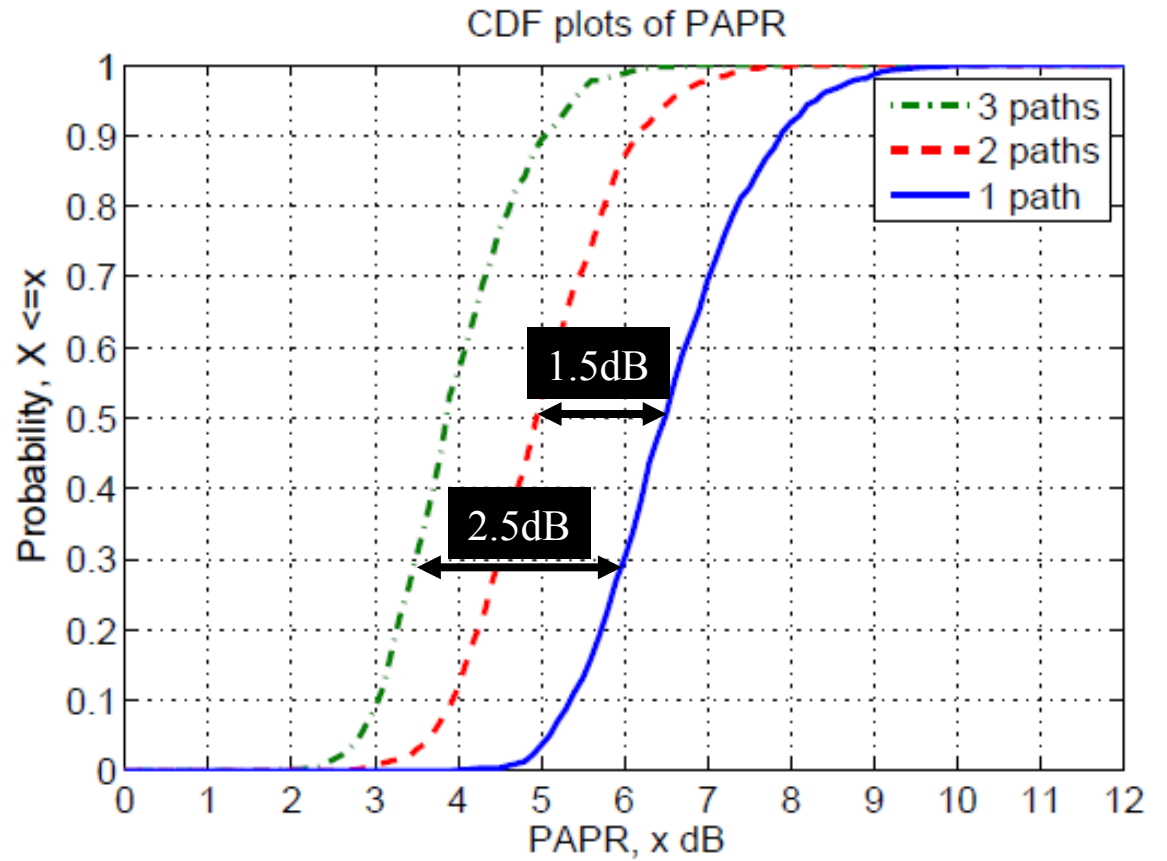
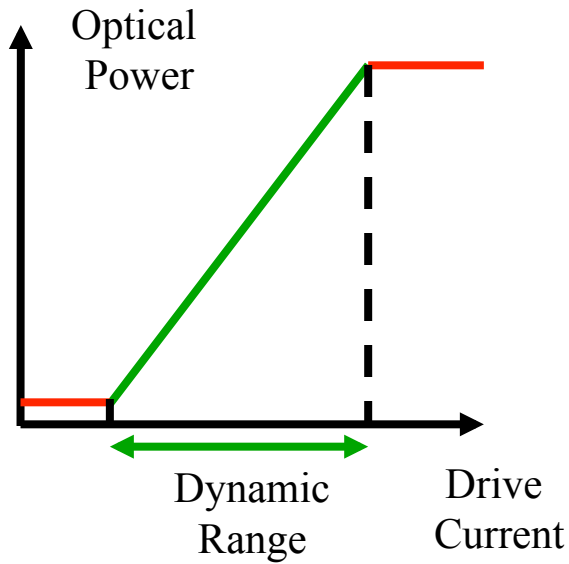

$$P_{\text{average per OFDM symbol}} = P_1 + P_2 + P_3$$

SEE-OFDM vs other hybrid techniques

PAM vs QAM! ACO vs DCO!

	Low Rates		Medium Rates		High Rates	
	QAM/PAM	Rate (bits/s/Hz)	QAM/PAM	Rate (bits/s/Hz)	QAM/PAM	Rate (bits/s/Hz)
ACO	64	1.50	128	1.75	N/A*	N/A*
HACO	8	1.45	16	1.94	N/A*	N/A*
SEE-2	16	1.50	32	1.88	64	2.25
SEE-3	8	1.31	16	1.75	32	2.18
SEE-3-Mix	8/16	1.50	16/32	1.94	32/64	2.38
ASCO	16	1.47	32	1.84	64	2.20
eU	16	1.45	32	1.82	64	2.18

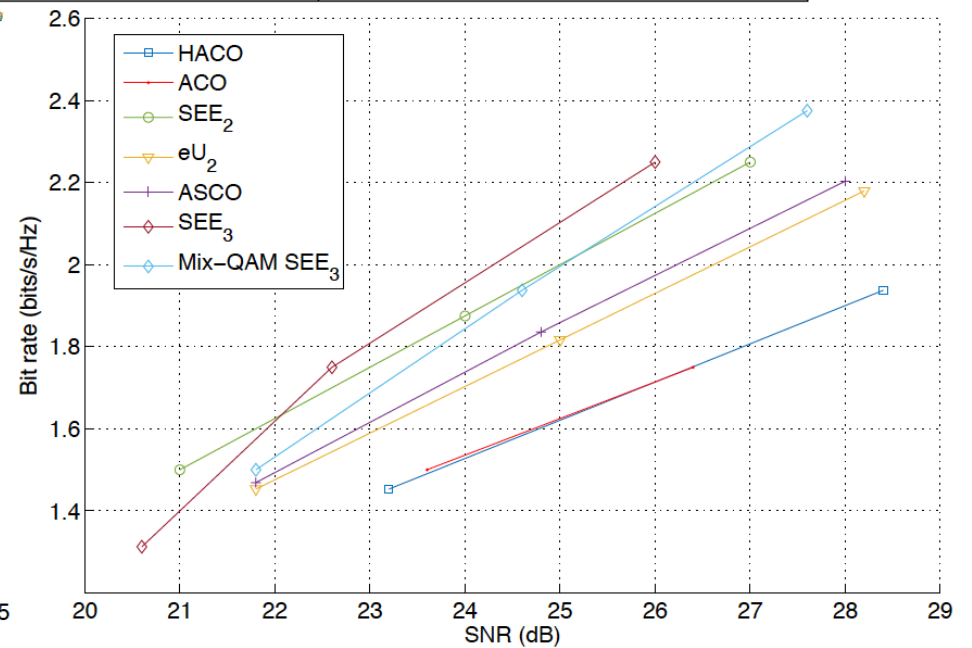
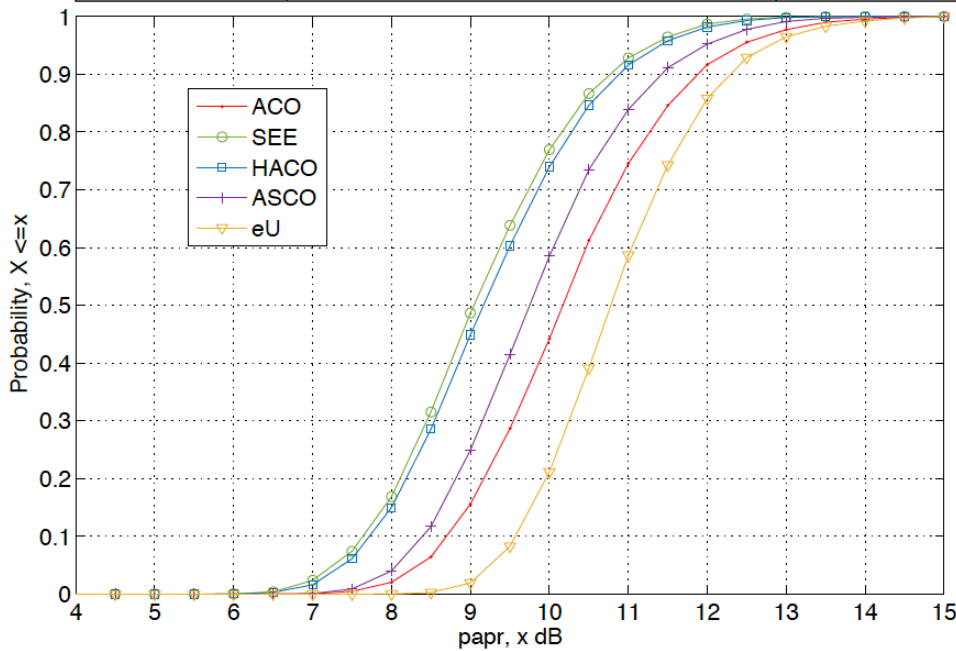

TX & RX: P-OFDM

Challenge: The optical version of OFDM is not spectrally efficient

- Spectral and energy efficient OFDM (SEE-OFDM)
- Polar-OFDM (P-OFDM)

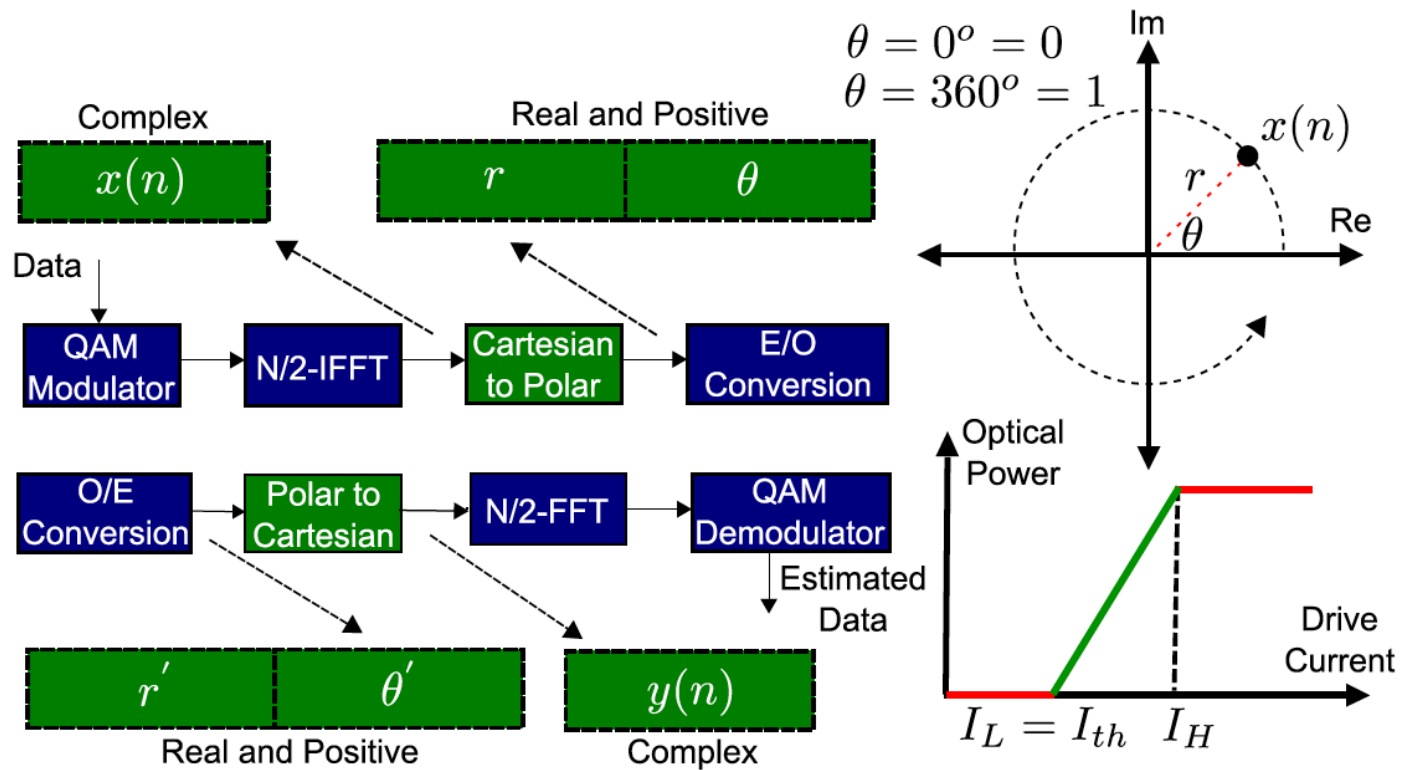

P-OFDM: time domain signal and PAPR

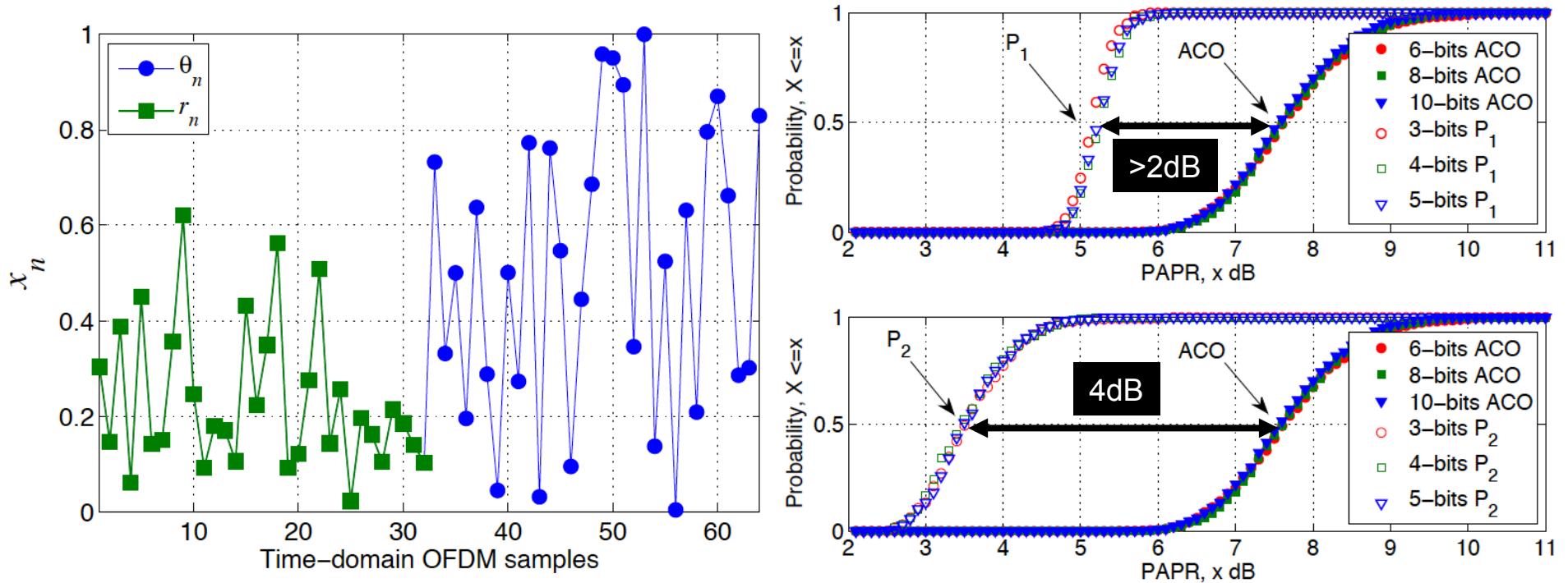

- Elgala, Hany, and Thomas DC Little. "P-OFDM: spectrally efficient unipolar OFDM." Optical Fiber Communication Conference. Optical Society of America, 2014.

P-SC-FDE: time domain signal and PAPR

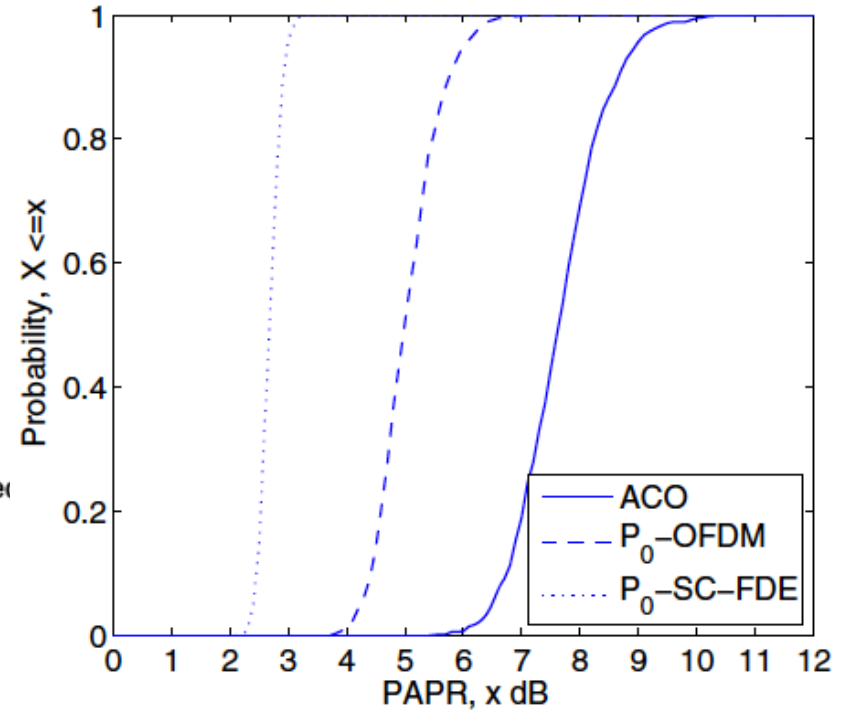
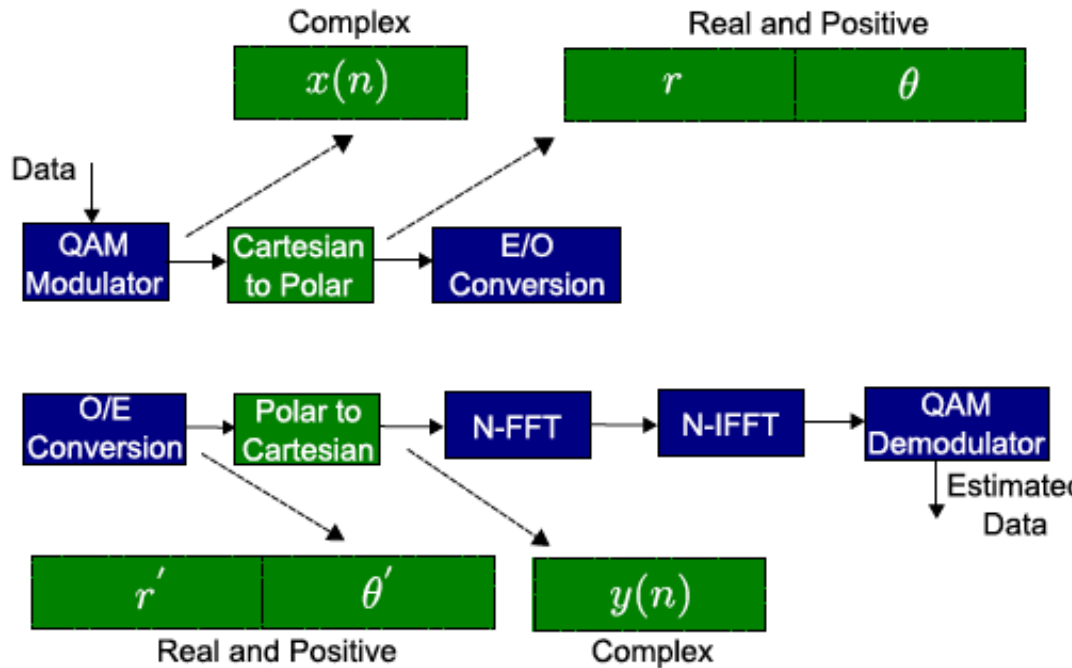

- Elgala, Hany, and Thomas Little. "Polar-based OFDM and SC-FDE links toward energy-efficient Gbps transmission under IM-DD optical system constraints [Invited]." Optical Communications and Networking, IEEE/OSA Journal of 7.2 (2015): A277-A284.

Conclusions

- RPO-OFDM works with any optical OFDM format
- Optical fiber community starts considering ACO-OFDM!
- It is not only about the spectral efficiency when choosing the best optical OFDM format?
 - a. PAPR
 - b. Complexity of Tx
 - c. Complexity of Rx
 - d. Integration of the cyclic prefix
 - e. Compatibility with RF-OFDM building blocks
- SEE-OFDM and P-OFDM have potential to fulfill the above