

Project: IEEE P802.15 Working Group for Wireless Personal Area Networks (WPANs)

Submission Title: Issues for exploiting short range networking for the design of energy efficient long range wireless networks

Date Submitted: January 20, 2014

Source: Jaehwan Kim (ETRI), Sangsung Choi (ETRI), Soo-Young Chang (SYCA), and Kyuyong Lee (A2UICT) Voice: +82 42 860 5338, E-mail: kimj@etri.re.kr

Re: [802.15 WNG presentation]

Abstract: Some technical issues for exploiting short range networking to connect a node to a long range wireless networks are addressed.

Purpose: To suggest some issues for exploiting short range networking to connect a node to a long range wireless networks.

Notice: This document has been prepared to assist the IEEE P802.15. It is offered as a basis for discussion and is not binding on the contributing individual(s) or organization(s). The material in this document is subject to change in form and content after further study. The contributor(s) reserve(s) the right to add, amend or withdraw material contained herein.

Release: The contributor acknowledges and accepts that this contribution becomes the property of IEEE and may be made publicly available by P802.15.

ISSUES FOR EXPLOITING SHORT RANGE NETWORKING FOR THE DESIGN OF ENERGY EFFICIENT LONG RANGE WIRELESS NETWORKS

INTRODUCTION

- **Exploiting short range networking for the design of energy efficient long range wireless networks**
 - Energy efficient short-range data transmissions assisted by cellular networks
- **A case that a node having limited energy needs communications with a remote node is considered.**
 - This node can communicate with the remote node through help from an adjacent device as a relay.
 - Vertical handover can be applied to save energy while communicating more energy efficiently.
- **For this case, some technical issues should be solved to apply vertical handover and/or to implement communication means to this node.**
- **In this document, three issues are identified.**

OPERATION SCENARIO (1)

Components:

- Node
 - mobile terminal that wants to minimize the energy consumption due to lack of or to save remaining energy
- Partner
 - neighboring terminal

Operation scenario:

- A node transmits frames to a partner,
 - with an air interface for short-range communication networks (e.g., WLAN or high-speed WPAN), instead of directly transmitting/receiving frames to/from a base station (BS) with an air interface for long-range cellular networks.
- The partner relays the frame received from the node to a base station (BS) with an air interface for long-range cellular networks.
 - The partner can also be a WLAN access point (AP) that performs the cognitive vertical handover to different RATs.
 - The partners can have sufficient amount of energy to provide relay function to the node.
- They operate under the management of the BS.
 - The packets transmitted by the partners contain control information for this cooperation.

OPERATION SCENARIO (2)

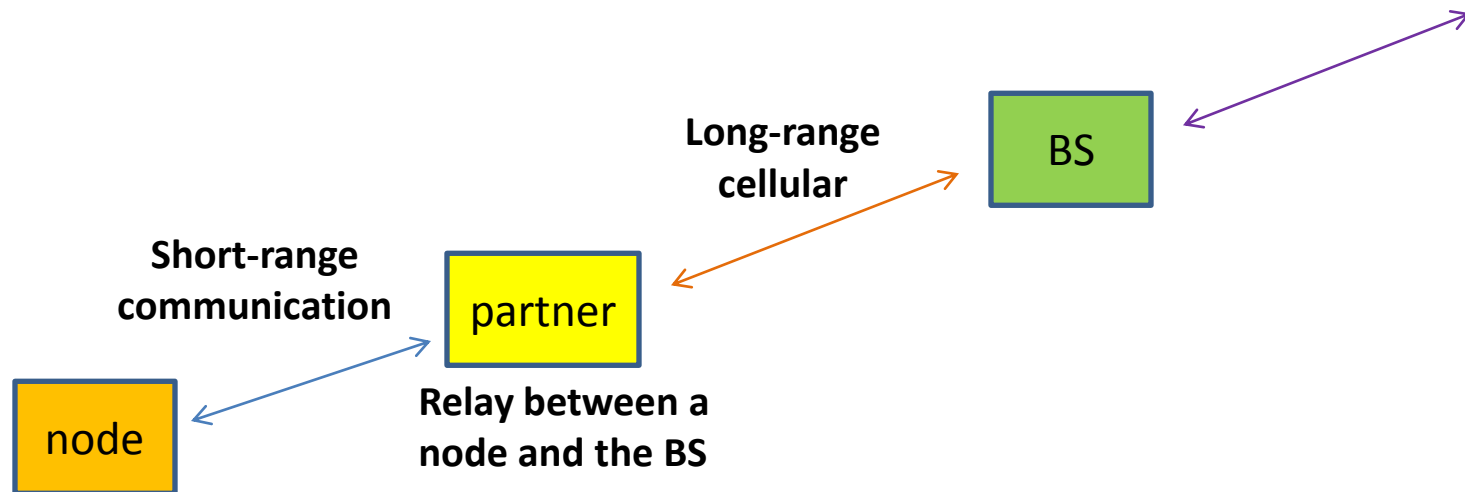

ISSUES IDENTIFIED (1)

- **Exploiting short range networking for the design of energy efficient long range wireless networks**
 - **Energy efficient short-range data transmissions assisted by cellular networks**

To achieve the above goal,

- **Issue 1: Energy efficient node discovery mechanisms**
 - To reduce the energy consumed in discovering neighboring nodes to exploit short-range cooperation or cognitive handover
- **Issue 2: Design of energy efficient cooperative PHY, MAC, and network layers**
 - To reduce the energy consumed for decoding the unnecessary frames delivered to the unintended receivers.

ISSUES IDENTIFIED (2)

- **Energy efficient RAT identification and selection**
 - Energy efficient identification of available RATs with assistance from other nodes

For the above goal

- **Issue 3: Green Cognitive Handover**
 - In order to minimize the energy consumption and maintain satisfactory QoS through the cognitive vertical handover, it is necessary to select the best RAT (radio access technology) among available RATs identified.
 - The objective is to reduce energy consumption for identification of the best RAT by aid of neighboring nodes.

VERTICAL HANDOVER

- Automatic fall-over from one technology to another in order to maintain communication
 - changing the data link layer technology used to access the network
 - for a network node which is changing the type of connectivity used to access a supporting infrastructure
 - usually to support node mobility.

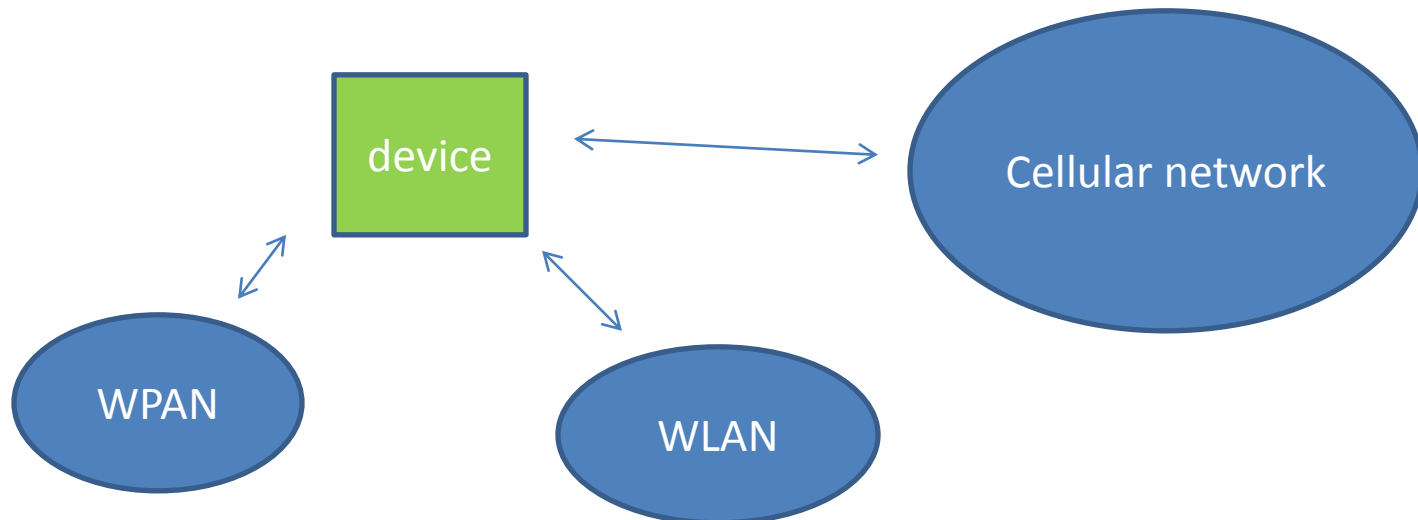

ONE EXAMPLE, VERTICAL HANDOVER

- A laptop/tablet might have ability to use both a high speed wireless LAN and a cellular technology for Internet access.
 - Thus the laptop/tablet user might want to use a wireless LAN connection whenever one is available, and to 'fall over' to a cellular connection when the wireless LAN is unavailable.

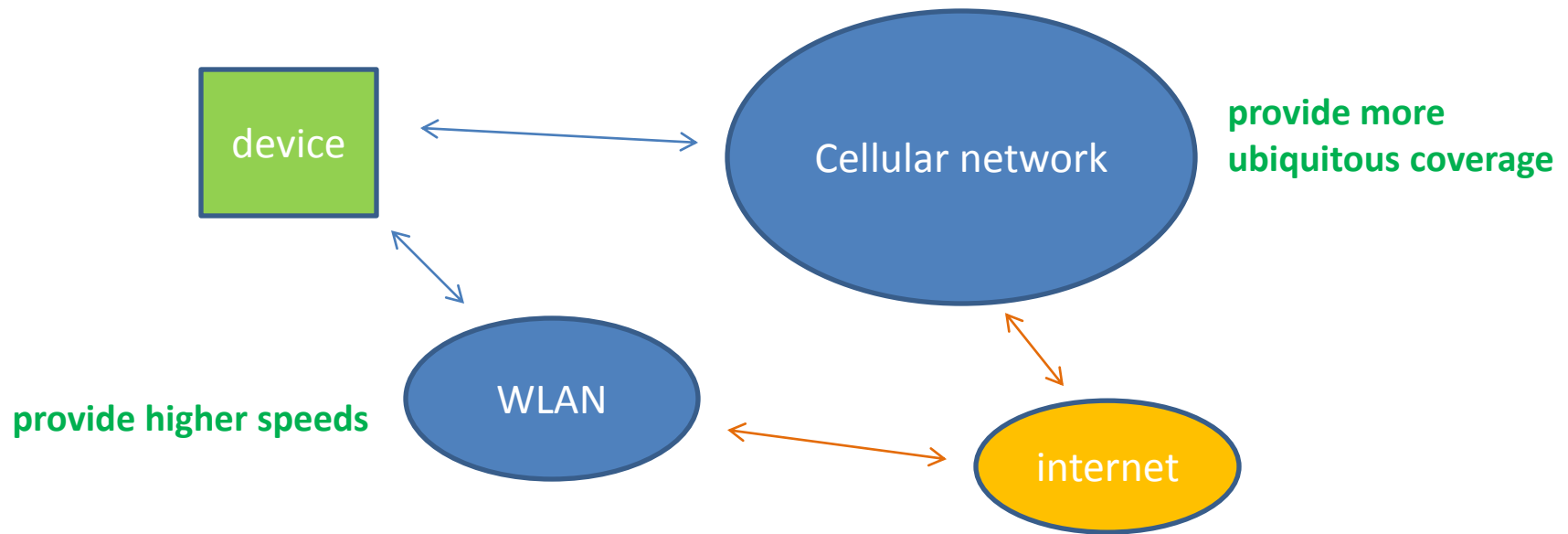

PROBLEMS TO BE SOLVED (1)

Problem 1:

- **Devise a mechanism for a node to discover potential partners to reduce its energy consumption.**
 - For this purpose, the partners periodically broadcast advertisement messages to inform the neighboring node of the availability of cooperation.
 - Consequently, a node should activate the air interface for short-range communication to discover partners.
 - The energy consumed for discovering the partners should not be significant as the number of partners increases.

PROBLEMS TO BE SOLVED (2)

Problem 2:

- **Devise a mechanism for a node to minimize its energy consumption for decoding unwanted frames.**
 - The node can reduce the energy consumption due to short-range communication; however, it still consumes the non-negligible energy in receiving frames from the partner even though it is not the intended receiver which is supposed to use these frames.
 - The reason is as follows.
 - The frame transmitted into the wireless channel is broadcasted essentially and it can be identified with the unique IDs such as cell/station ID or MAC address.
 - Unlike cellular networks where the cell ID is included in the physical (PHY) header, WLANs or high-speed WPANs include MAC address in the MAC header without containing cell ID or station ID in the PHY header.
 - Therefore, a WLAN/WPAN node cannot figure out whether it is the intended receiver of the received frame until it decodes the MAC header with a considerable amount of energy consumed in decoding unnecessary frames.

PROBLEMS TO BE SOLVED (3)

Problem 3:

- **Devise a mechanism for a node to select the best RAT to reduce the energy consumption.**
 - The number of available RATs increases accordingly,
 - as the new wireless communication systems emerge and they evolve, and
 - also, as the cell size tends to decrease and a single RAT may employ multiple frequency bands, in order to increase the spectral efficiency and/or network capacity.
 - Therefore, there may exist lots of WLAN access points (APs) or WPAN coordinators that are located close to a node and operates with the same RAT and frequency bands.
 - The node probably has to perform complex and numerous procedures for neighbor scan and/or association to determine the best target AP/coordinator.
 - The primary objective of this vertical handover is to minimize the energy consumption of the node that lacks the remaining energy.
 - Thus, it is more desirable for such a node to consume less energy for identifying numerous RATs.

POSSIBLE MECHANISM (1)

PARTNER DISCOVERY MECHANISM

Mechanisms for reducing the energy consumption for partner discovery

- The BS informs nodes and partners of the operation scenario of discovery advertisement, including the period of advertisement (denoted as T_{adv}) and channel access rule.

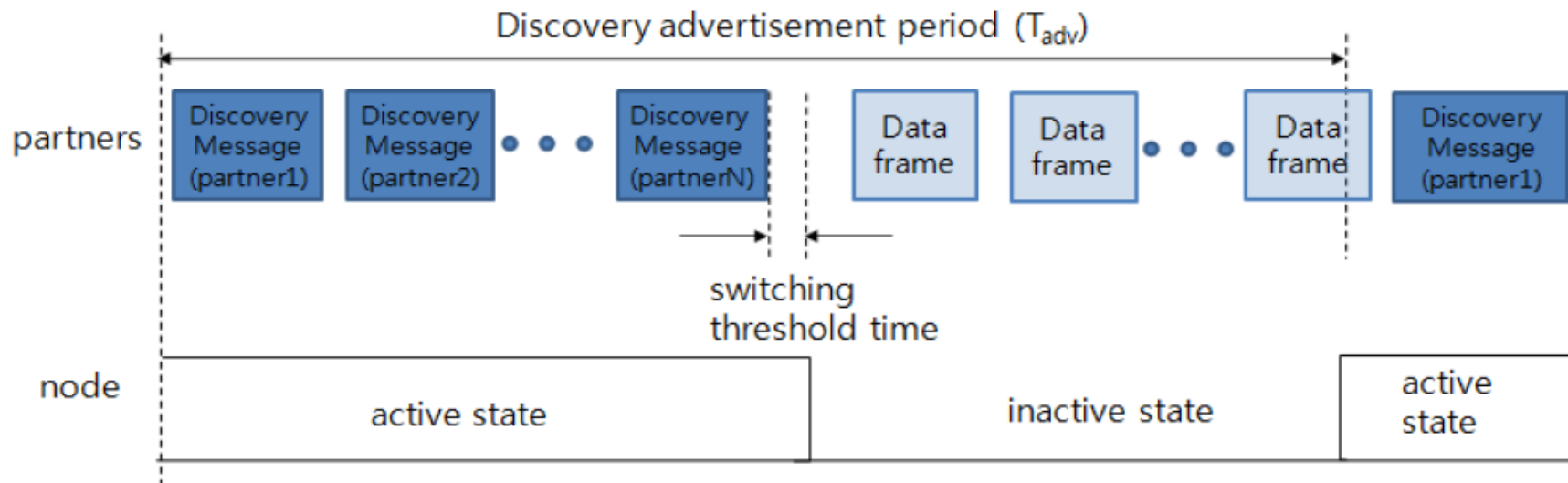

Fig. 1. Broadcasting of neighbor discovery message

POSSIBLE MECHANISM (2)

PARTNER DISCOVERY MECHANISM

- All partners are allowed to broadcast the advertisement messages in a contention-based manner once in every period of T_{adv}
- The node alternates active and inactive states within the advertisement period of T_{adv} ;
 - the node activates the air interface for short-range communication only in the active state but turns it off in the inactive state.
- The period of active state is terminated if the channel is sensed as idle longer than a threshold time.
- The key assumption is that the clock is synchronized among all partners and nodes.
 - They synchronize the clock using the reference timing information transmitted by the BS.

POSSIBLE MECHANISM (3) PARTNER DISCOVERY MECHANISM

- If the partner (e. g., WPAN coordinator or WLAN AP) does not have the cellular transceiver, a simplified cellular modem can be added in the non-cellular partner.
 - The simplified cellular modem consists of the minimal components to extract exact timing information from the signal transmitted by the BS.

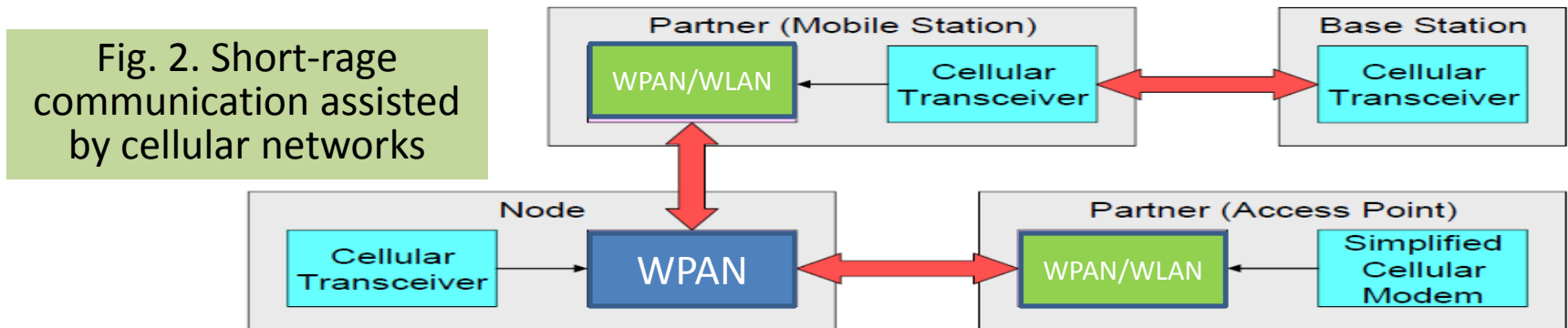

- The energy efficiency of the discovery process is directly related to the ratio of active state to the discovery period (T_{adv}).
 - The duration when the nodes are in the active state needs to be minimized.
 - At the same time, in order to improve the transmission reliability of broadcasting discovery message, the collisions among the discovery messages that are transmitted according to the contention-based CSMA (carrier sense multiple access) mechanism need to be minimized.

POSSIBLE MECHANISM (4)

PARTNER DISCOVERY MECHANISM

- Considerations needed
 - (1) the broadcasting discovery message may compete with the data frame,
 - (2) it is hard to employ acknowledgment scheme for the broadcasting discovery message.
- A differentiated channel access mechanism to cope with these challenges should be devised.
- The proposed mechanism aims to achieve the following two objectives:
 - (1) to minimize the active duration by **allowing for partners to broadcast the discovery message with a high priority over the data frame,**
 - (2) to maintain the collision probability of the broadcasting discovery message below the tolerable level by adjusting the size of contention window (CW).

POSSIBLE MECHANISM (5)

PARTNER DISCOVERY MECHANISM

Proposed mechanism 1: Prioritized channel access mechanism

- This mechanism is similar to the IEEE 802.11e EDCA (enhanced distributed channel access) mechanism.
 - High-priority traffic has a higher chance of being sent than low-priority traffic.
- The values of inter-frame space and CW for the data frame are set larger than those for the discovery message ¹.
 - In this way, the data frame cannot be transmitted until all discovery messages are transmitted, and the duration of active state can be decreased.
 - By carefully designing the inter-frame space and CW for the discovery message and data frame, the switching threshold time can be set properly.
 - If the node senses the channel to be idle longer than the determined threshold time, the node recognizes that all the discovery messages are transmitted and it changes its state to the inactive state until the next discovery advertisement period.

¹ The guideline to set the optimal contention window size for the discovery message will be given in the next slide.

POSSIBLE MECHANISM (6)

PARTNER DISCOVERY MECHANISM

Proposed mechanism 2: Mechanism for optimal size of CW for discovery message

- According to the CSMA mechanism, before transmitting a frame, each partner determines the random back off counter within the size of CW.
 - It is decreased as long as the channel is sensed idle.
 - If the channel is sensed busy, the partner holds the counter and resumes decreasing when the channel becomes idle.
 - Eventually when the counter becomes zero, it starts to transmit the discovery message.
- In setting the size of CW, there occurs a trade-off between collision probability and channel access delay.
 - As the size of CW increases, less collision occurs at the cost of increased access delay.
- In the case of unicast, the acknowledgement (ACK) can be used as a measure of collision and the size of CW can be adjusted dynamically.
 - With the well-known binary exponential backoff mechanism, the CW is doubled whenever a node does not receive the ACK within the expected time.
- in the case of broadcasting, such adaptation cannot be applied since there is no ACK.
 - To deal with this problem, an analytical model can be derived to investigate the effects of CW and the number of active partners on the collision probability and access delay.
 - With this model, the number of active partners can be estimated and the size of CW can be determined as the smallest value that assures tolerable target collision probability.

POSSIBLE MECHANISM (7)

PARTNER DISCOVERY MECHANISM

Summary:

- The partners can synchronize the clock and transmit discovery messages from the start time of discovery advertisement period in a contention-based way.
- The discovery message is transmitted with a higher priority over data frame and the collision probability can be maintained below the tolerable level.
- Therefore, nodes need to be active state at the minimal time, and thus, they can minimize the energy consumption for discovering partners.

POSSIBLE MECHANISM (1)

FRAME DECODING MECHANISM

Mechanism to avoid decoding unwanted frames:

- Energy consumed by the nodes can be minimized to decode unnecessary frames
 - by adding a specific unique signature in the frame transmitted by the partners.
- The frequency offset can be used as a signature.
 - For this purpose, all mobile terminals should synchronize the carrier frequency using the signal transmitted by the BS.
 - If the partner (e.g., WPAN coordinator or WLAN AP) does not have the cellular transceiver, a simplified cellular modem can be added in the non-cellular partner.

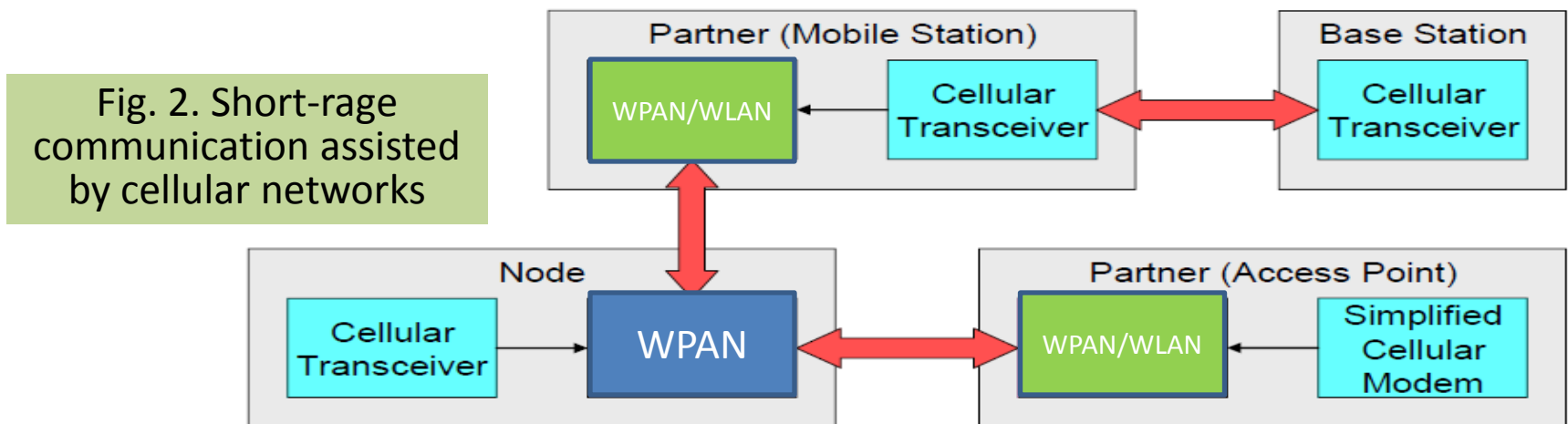

POSSIBLE MECHANISM (2)

FRAME DECODING MECHANISM

Mechanism to avoid decoding unintended frames (cont'd):

- Once all nodes and partners synchronize the carrier frequency, each partner determines different (or random) frequency offset and makes it as its own signature ².
 - On the other hand, a node estimates the frequency offsets of the partners during partner discovery procedure and makes them as IDs of the partners.
 - It is also possible for the node to determine the frequency offset during the association procedure.
- A node receives frames with the specific frequency offset from the intended partner.
 - However if the frames have different frequency offset, the node just discards frames and does not consume energy in decoding them.
- The node can distinguish frames transmitted from the intended partner from frames transmitted from the non-intended partner.
 - It does not necessarily decode all the frames received. **The proposed mechanism can further reduce the energy consumption in short-range communication.**

² It is possible for multiple partners to determine the same frequency offset. however this case happens rarely when the set of frequency offsets is sufficient. .

POSSIBLE MECHANISM (3) FRAME DECODING MECHANISM

Mechanism to avoid decoding unintended frames (cont'd):

Fig. 3. Communication between a node and partners with different frequency offsets

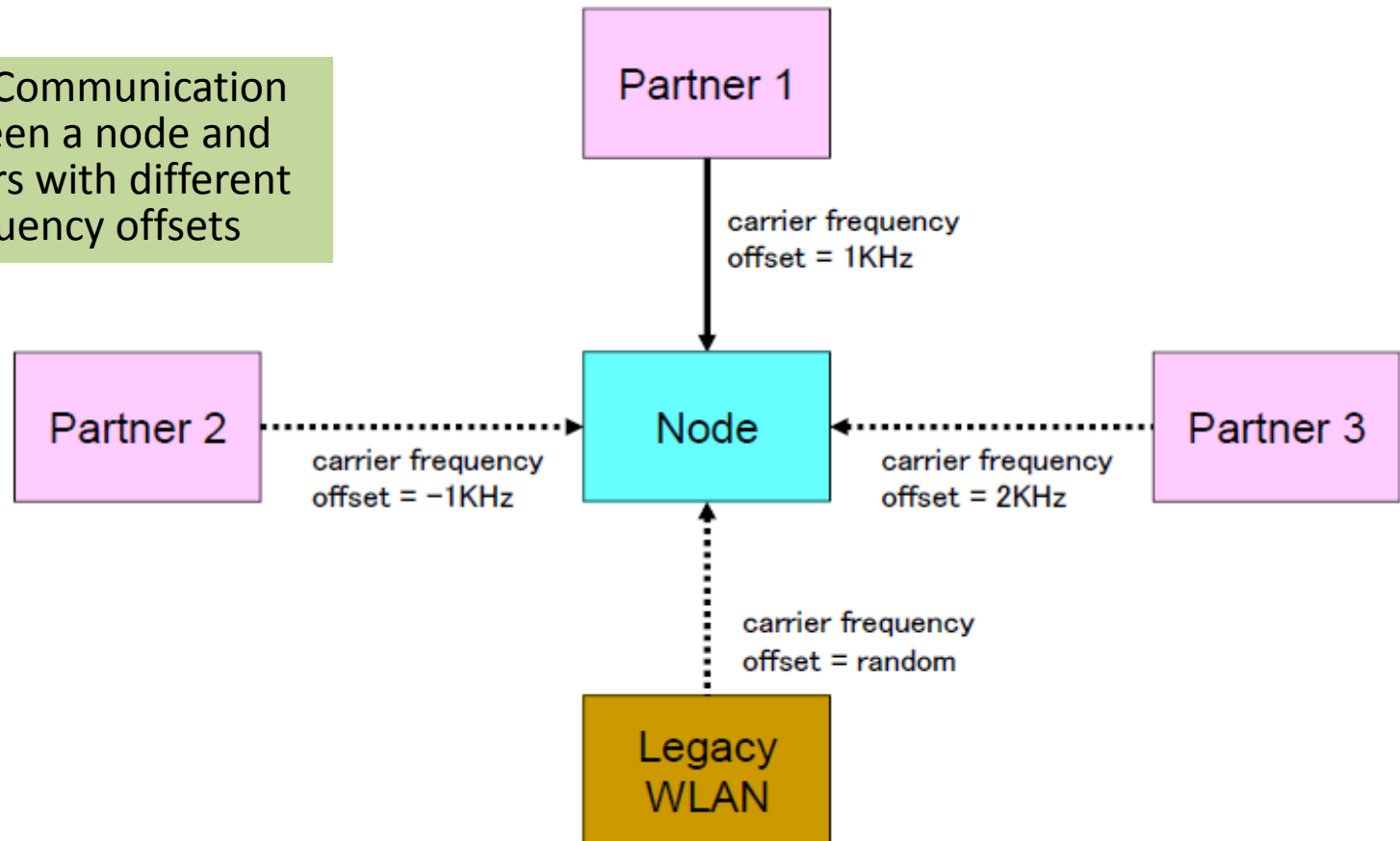

POSSIBLE MECHANISM (1)

RAT SELECTION MECHANISM

Mechanism to select the best RAT:

- The **helper node** and **beneficiary node** are defined as follows as depicted in Fig. 4:
 - Every node periodically reports the remaining energy to the BS.
 - The BS determines helper nodes that have enough energy and sends them the request message to serve as helper nodes periodically.
 - Once accepting the request, the helper node searches available RATs and checks the available resource in the identified RATs.
 - The helper nodes advertise the collected information about available RATs to the neighboring nodes at the specific time, frequency, and RAT determined by the BS.
 - The beneficiary nodes receive the information on available RATs advertised by the helper nodes and make the vertical handover decision to the best RAT.

POSSIBLE MECHANISM (2) RAT SELECTION MECHANISM

Mechanism to select the best RAT (cont'd):

Fig. 4. Procedure of energy-efficient RAT discovery assisted by helper nodes

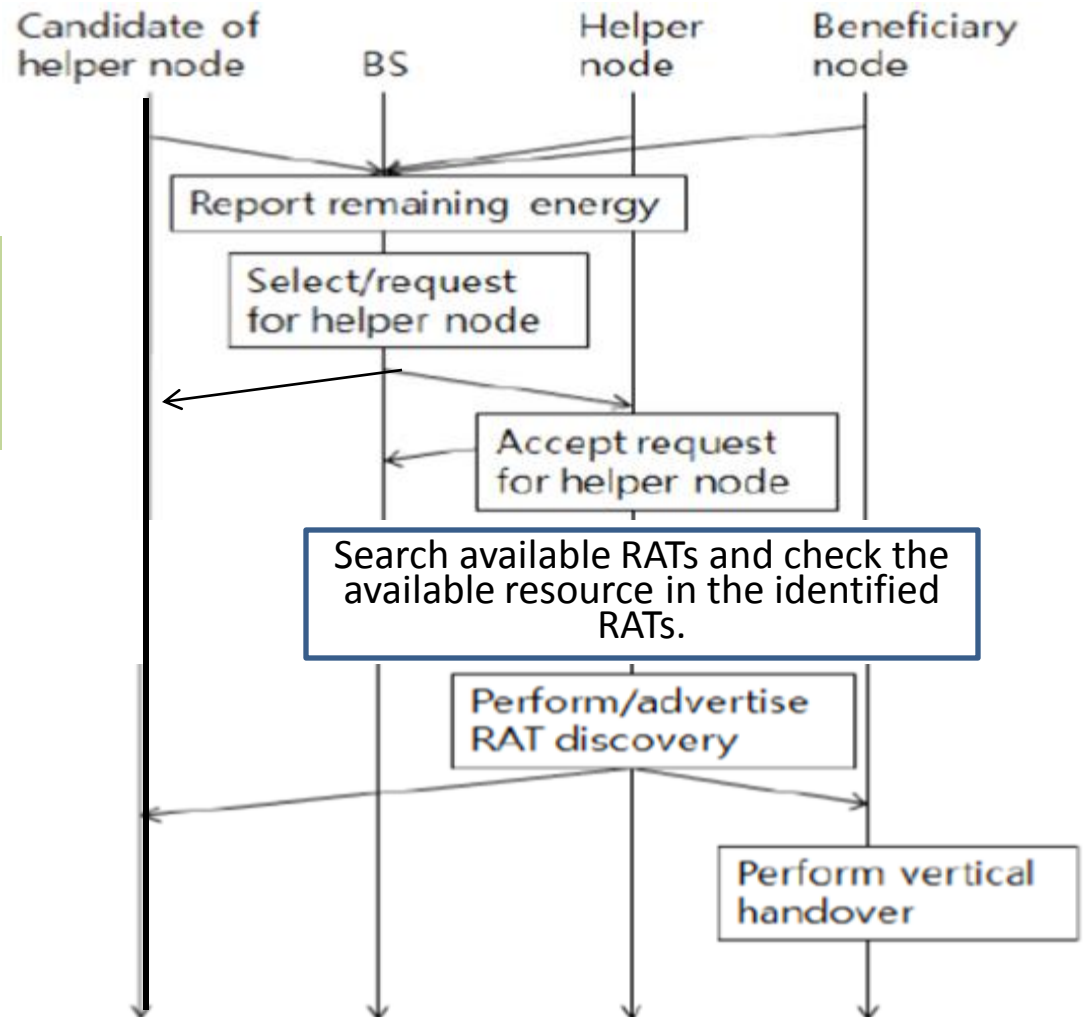

POSSIBLE MECHANISM (3)

RAT SELECTION MECHANISM

- One of key points is to manage the number of helper nodes properly so that they are distributed uniformly around the beneficiary nodes.
 - If the number of helper nodes is excessive, they incur large signaling overhead (i.e., advertisement of unnecessary duplicate RAT discoveries).
 - If the number of helper nodes is insufficient, the beneficiary node may not make the best handover decision (i.e., QoS degradation or unacceptable energy consumption).
- To deal with this problem, the BS estimates the location information of helper nodes by measuring the received signal strength (RSS) of helper nodes.
 - For example, if the RSSs of two helper nodes are comparable, the BS selects one that has more remaining energy between these two helper nodes and remove the other in the list of helper nodes.
- The BS selects another helper node as long as the minimum difference between its RSS and those of existing helper nodes exceed a certain threshold.
 - In this way, a suitable number of helper nodes are maintained and they are distributed uniformly.
 - Moreover, the BS reselects the helper nodes periodically based on the reported information of remaining energy, to avoid energy exhaustion in a certain helper node.

POSSIBLE MECHANISM (4)

RAT SELECTION MECHANISM

- How the beneficiary node can make use of identified RAT information advertised by the helper nodes.
 - The beneficiary nodes may receive multiple RAT discovery advertisements and it has to select the best RAT for handover among them.
 - It is assumed that the RSS is inversely proportional to the distance between transmitter and receiver and that the transmission energy increases as the transmission distance increases.
 - Under this rationale, the beneficiary node makes use of the information delivered in the RAT discovery advertisement that has the highest RSS, which can be considered to be transmitted by the helper node located in close proximity to the beneficiary node.
 - With this RAT discovery information, the beneficiary node determines the best target RAT that assures the required QoS with the minimal energy consumption.
 - If there does not exist a target RAT assuring the required QoS, the beneficiary node makes use of another RAT discovery advertisement that has the next higher RSS.
- Consequently, the helper nodes perform and advertise RAT discovery for the beneficiary node, and the beneficiary node can perform vertical handover with the minimal energy consumption while maintaining acceptable QoS.

SUMMARY AND CONCLUSION

- In this document,
 - Three issues are identified
 - for a node which exploits only short range communications with limited energy and needs to connect to long range networks
 - by utilizing a neighboring device as a relay device.
 - Problems are defined for these issues.
 - Some possible mechanisms for these problems are suggested.
- These should be more investigated for the further study.
 - with consideration of real environments and with performance analyses from practical implementation