

**Project: IEEE P802.15 Working Group for Wireless Personal Area Networks (WPANs)**

**Submission Title:** On the Scope of IEEE 802.15 SG 100G

**Date Submitted:** 11 November 2013

**Source:** Thomas Kürner Company TU Braunschweig

Address Schleinitzstr. 22, D-38092 Braunschweig, Germany

Voice:+495313912416, FAX: +495313915192, E-Mail: t.kuerner@tu-bs.de

**Re:** n/a

**Abstract:** This presentation gives some background information and the scope of IEEE 802.15 SG 100G.

**Purpose:** Information on the Scope of IEEE 801.15 SG 100G in the 802.1 / 802.15 TG10 / 802.15 SG100G Joint Session

**Notice:** This document has been prepared to assist the IEEE P802.15. It is offered as a basis for discussion and is not binding on the contributing individual(s) or organization(s). The material in this document is subject to change in form and content after further study. The contributor(s) reserve(s) the right to add, amend or withdraw material contained herein.

**Release:** The contributor acknowledges and accepts that this contribution becomes the property of IEEE and may be made publicly available by P802.15.

# On the Scope of the IEEE 802.15 SG 100G

Thomas Kürner  
TU Braunschweig

# Outline

- Background in IEEE 802.15 IG THz (2008-2013)
- Working towards a Study Group targeting wireless 10x Gbps
  - Some Boundary Conditions
  - Investigating possible Applications
  - Some thoughts on Wireless Data Centers
  - Investigating on which MAC to build on
  - Some thoughts on the PHY
  - Motion to form a Study Group
- Current Status of the Study Group

# Some Background – Scope of the IEEE 802.15 IG THz (2008 – 2013)

Based on the slides from our 2nd Tutorial given at IEEE 802 Plenary in July 2012

(IEEE 802.15-12-0320-01-0thz\_Tutorial\_Igthz)

-

# Evolution of Data Rates in Wireless

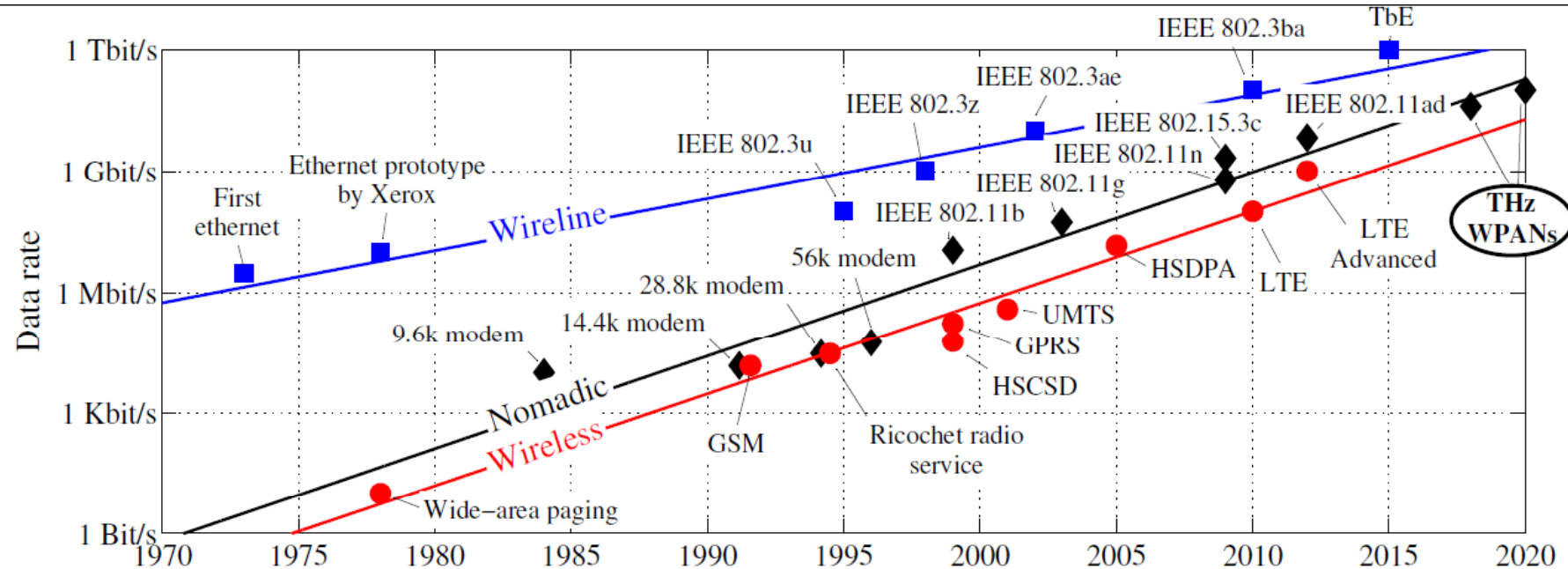

- 60 GHz Standards already completed or currently under development enable data rates of 6-7 Gbit/s
- Assuming the development observed in the past years extrapolate into the future we will see wireless 100 Gbit/s around the 2020

# How much data can be transferred in one second?

Data rate	Size	Run time of 1080p24 video(*)
10 Gbps	1.25 GByte	4 min
40 Gbps	5.0 GByte	17 min
<b>100 Gbps</b>	<b>12.5 Gbyte</b>	<b>42 min</b>
<b>1 Tbps</b>	<b>125 Gbyte</b>	<b>7 hours</b>

(\*)1080p24 video are hold on BlueRay-Discs and run at up to 40-Mbps rate  
(source: <http://en.wikipedia.org/wiki/1080p24>)

# What do we need x10 Gbit/s for?

- Aim: Ultra high data rates of 100 Gbit/s and beyond over rather short distances
- Potential scenarios:



(1) WPAN



(2) Kiosk downloads

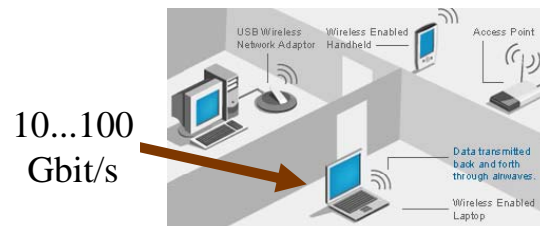

(3) WLAN

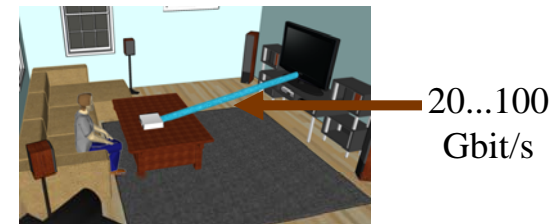

(4) Video streaming

→ But: Why using THz communications to achieve these data rates?

# Why choosing THz frequencies?

- Spectrum allocations by the ITU below 300 GHz:



[http://discovermagazine.com/2007/jun/tireless-wireless-wireless-allocchrt\\_lg.jpg](http://discovermagazine.com/2007/jun/tireless-wireless-wireless-allocchrt_lg.jpg)

→ No free spectrum available below 300 GHz to achieve such high data rates with moderate spectral efficiencies

→ **No dedicated frequency allocation beyond 300 GHz (0.3 THz)**



# THz @ IEEE 802.15: IG THz

- Already in 2008 IEEE 802.15 has established a THz Interest Group for Wireless Systems operating at 300 GHz and beyond
- Tasks of IEEE 802.15 THz Interest Group
  - Survey of technological developments
  - Channel modeling
  - Spectrum Issues (Interference studies THz Communications -> passive services)
  - Generating a Technical Expectations Document (TED)
  - Triggering the formation of one or more Study Groups to develop one or more standards
- Chair: Thomas Kürner (TU Braunschweig, Germany)
- Vice-Chair: David Britz (AT&T Shannon Labs, USA)
- Secretary: Katsuhiro Ajito (NTT Corp., Japan)
- Editor of TED: Rick Roberts (Intel, USA)

# Challenges to be addressed to make THz communication happen

- Propagation Channel beyond 300 GHz
  - To overcome the high path loss high-gain antennas in combination with beamforming/beamsteering are required
  - @100 Gbit/s only extremely low RMS delay spread in the order of a few ns can be tolerated
    - > High-gain antennas can also help to reduce the impact of multipath propagation
- Transmission and Networking
  - Appropriate solutions for PHY and MAC have to be defined
- Technology
  - In order to allow highly integrated transceivers technology with transit frequencies beyond 1 THz is required
  - Electro-optical or electronic generation of THz signals?

# Chip Set for 220 GHz Transmission

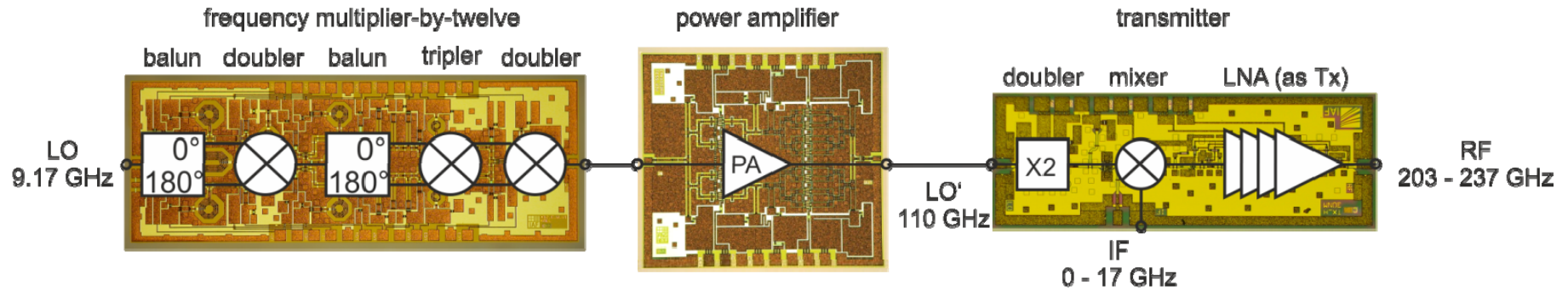

Technology: IAF 50 nm mHEMT  $f_T/f_{max}$  515/900 GHz

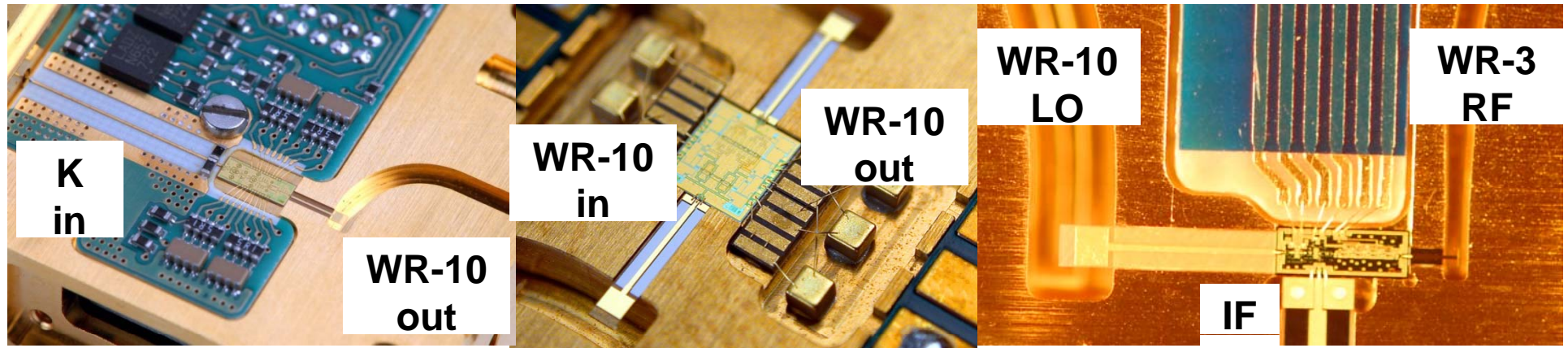

# 220 GHz Transmission Experiments

Setup	Rate	Dist.	Quality
Coherent LO	25 Gbit/s	10 m	Q > 3
	15 Gbit/s	20 m	
	Full DVB-S	20 m	n/a
	30 Gbit/s	n/a	BER < 10 <sup>-3</sup>
	16 Gbit/s	2 m	Q <sup>2</sup> > 13.9
Incoherent LO	16 APSK/ 1 GBd/s	3 m	EVM 9.7%
	QPSK/ 2 GBd/s	3 m	BER 10 <sup>-8</sup>

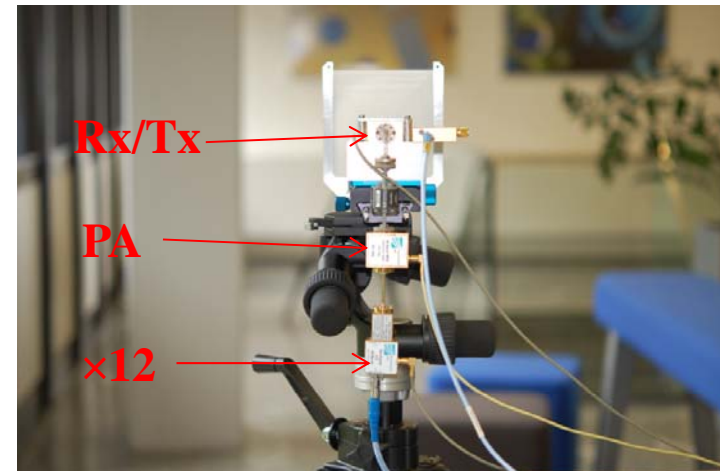
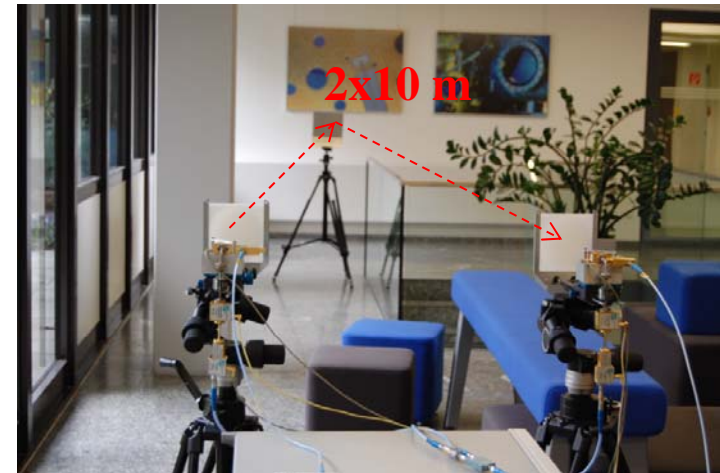

Antes et. al. EuMIC 2011

# Conclusions from July 2012 Tutorial to the IEEE 802 Plenary

- Recent achievements in technology development have clearly shown that building wireless systems with ultra-high data rates @ carrier frequencies of 300 GHz and beyond is feasible.
- First successful demonstrations of wireless data rates 25 Gbit/s over a distance of 10m
- Various applications feasible for THz communications are under consideration in numerous research projects
- Although some sharing issues still exist, the assumption can be made that appropriate spectrum is available.

# Working towards a Study Group targeting wireless 10x Gbps ....

## Part I: Some Boundary Conditions

Based on slides presented to IEEE 802.15 WNG in March 2013  
(15-13-0130-01-0thz-launching\_a\_study\_group\_on\_thz)

-

# State of the art in technology for THz Communications (1/2)

- > 20 Gbps have been demonstrated by various groups
  - Song et. al. [1] demonstrated 24 Gbit/s at 300 GHz using an electro-optical transmitter and an electronic receiver.
  - Kallfass, Antes et al [2,3] demonstrated 25 Gbps at 220 GHz over a distance of 10 m using InP/GaAs based MMIC technology
- CMOS solutions at THz frequencies are challenging
  - However, first approaches are promising and show a clear potential (see e. g. 15-12-0621-00-0thz\_THz\_CMOS)

# State of the art in technology for THz Communications (2/2)

- Current demonstrations are focussing on point-to-point links only.
- Many applications require automatic beamsteering capabilities.
- Beamsteering has not been demonstrated yet (first projects targeting this may start soon)
- First systems to be standardised should not require full beamsteering capabilities.



# Mass Market vs. Non-Mass Market Applications

- Yet the more expensive compound semiconductor technology (InP, GaN, GaAs) seems to be mature enough.
  - Expensive technologies might be feasible for non-mass-market applications only
  - Willingness to pay for performance is necessary
- Cheaper CMOS technology can provide solutions in the future as well.
  - This will pave the way for mass-market applications targeting consumer electronics.
- From a technology point of view applications not targeting the consumer market seems to be more appropriate to start with.

# Working towards a Study Group targeting wireless 10x Gbps ....

## Part II: Investigating possible Applications

Based on slides presented to IEEE 802.15 WNG in March 2013  
(15-13-0130-01-0thz-launching\_a\_study\_group\_on\_thz)

# Selection of Possible Applications

	1.) Fixed links	2.) Data center links	3.) Intra device	4.) Kiosk	5.) WPAN	6.) WLAN
Multipath propagation	None		High; suppressible	Low	Medium-high	
Dynamics	None			Low	Medium	
Control over environment and TX/RX placement	High			Medium	None	
Beam alignment	Once during setup; manual			Not necessary	Initial alignment and tracking; automatic	
Multiple stations	No	Yes, time multiplex	No	No	Yes	
Access	Possible in THz band			Via conventional radio technology		

Type (a): No dynamic beam alignment, THz access, point-to-point

Type (b): Type (a) + conventional radio access

Type (c): Dynamic beam alignment, conventional access, multi-user

# Working towards a Study Group targeting wireless 10x Gbps ....

## Part III: Some thoughts on Wireless Data Centers

-

Based on 15-13-0130-01-0thz-launching\_a\_study\_group\_on\_thz and  
15-13-0411-00-0thz-Literature Review on Requirements for Wireless Data Centers

# Today's situation at data centers

- Due to rapid data explosion more data centers are required
- Data intensive systems may have hundreds of thousands of computers yielding enormous requirements for aggregate network bandwidth
  - In 2009 Google had 10 million servers
  - Microsoft had 50000+ servers in their data centers
- Architecture design of the data center is critical to the total performance
  - Requirements for easy reconfiguration
- Cabling complexity
  - Intensive cabling introduces problems like connecting efforts, maintenance and cooling

Source: [4]

# Adding wireless interconnections to data centers

- With pure wire solutions dynamic reconfiguration of data centers is not easy
- Wireless connections in the data center may help both in achieving easier dynamic reconfigurability and reduce cabling.
- [4] proposes a hybrid solution consisting of both wired and wireless connections
- In [5] a wireless data center based on IEEE 802.15.3c is proposed.
- [6] mentions explicitly THz frequencies to increase bandwidth and proposes out-of-band lower frequency channels based on IEEE 802.11s

# Example of a wireless data center

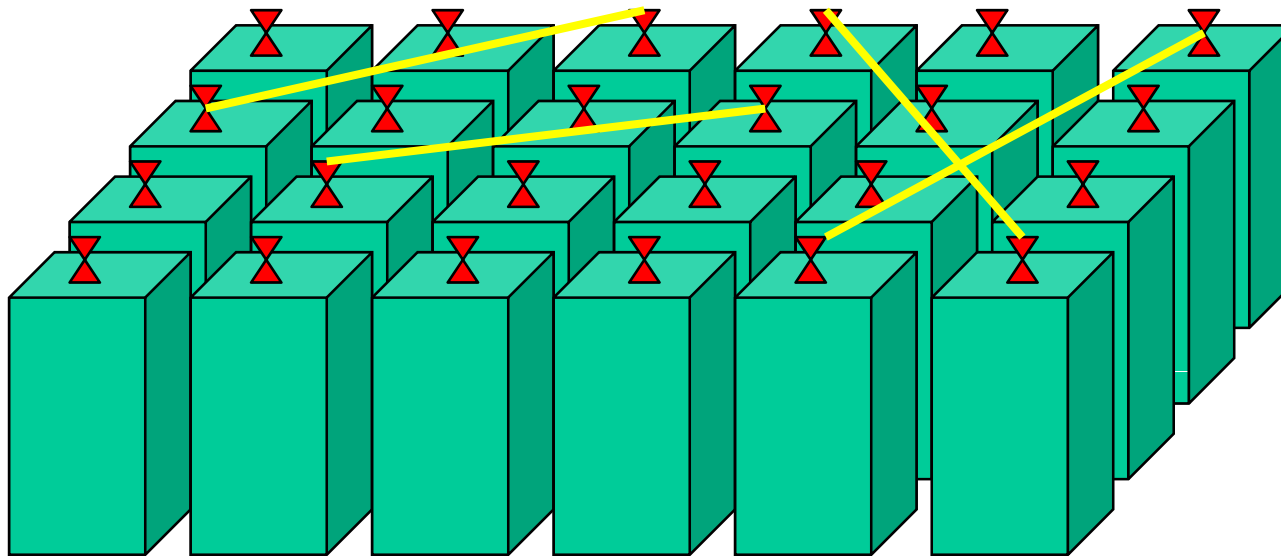

# Some properties of wireless connections in data centers

- Beamsteering and high gain antennas enhance spectral efficiency and reduce collision probability.
- Steered-beem control is optimized during system initialisation and stored until next system reconfiguration
- Due to lower transmission range and high penetration losses, high frequencies can enhance security
- In [7] 3D beamsteering using the ceiling as a passive relay is proposed to overcome potential shadowing by racks

Source: [6]



# LOS and Indirect LOS Paths [7,10]

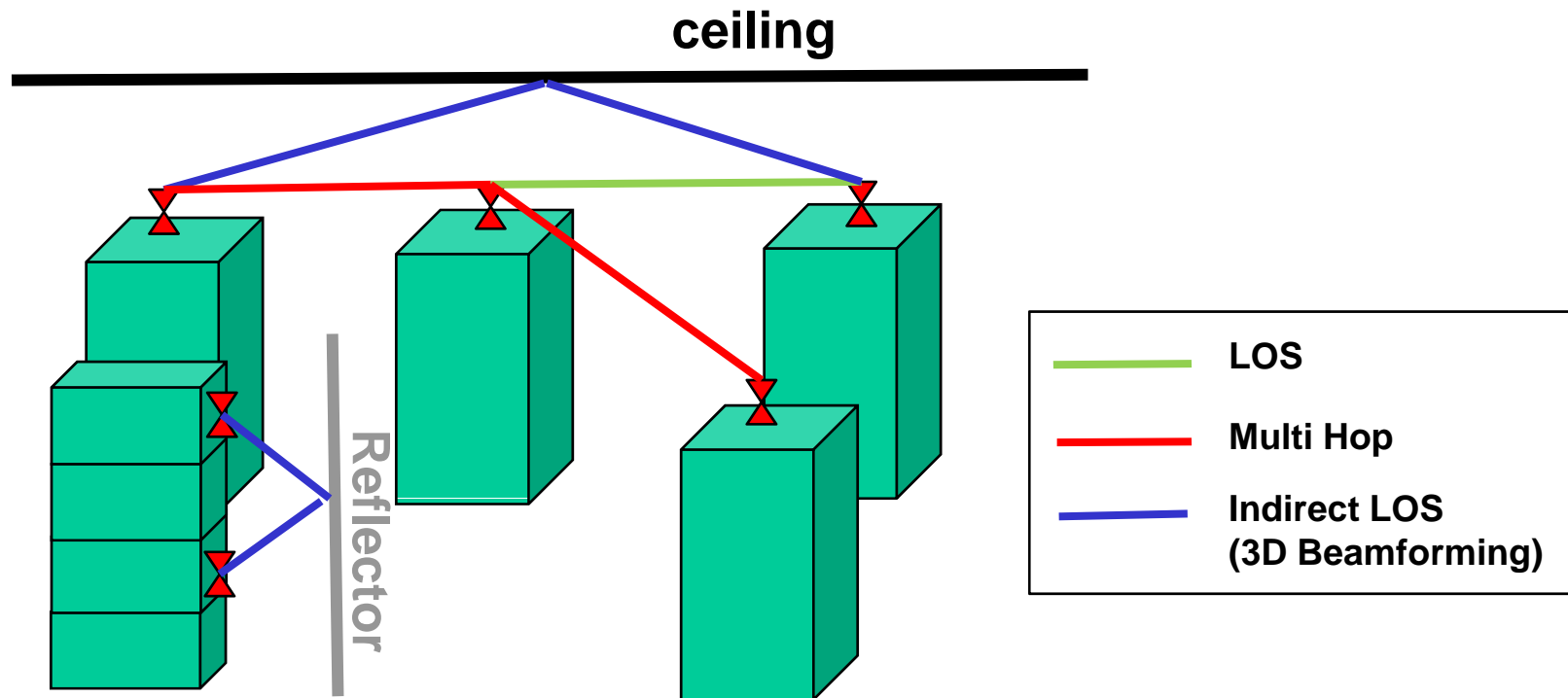

# Hardware Components required for 3D Beamforming via Ceiling [7]

- Beamforming capabilities both in azimuth and elevation
- Ceiling reflectors (aluminium plates or other good reflecting materials)
- Electromagnetic absorbers on top of the racks to prevent local reflection/scattering around the antenna

# Node Arrangements – Two Parallel Rows [5]

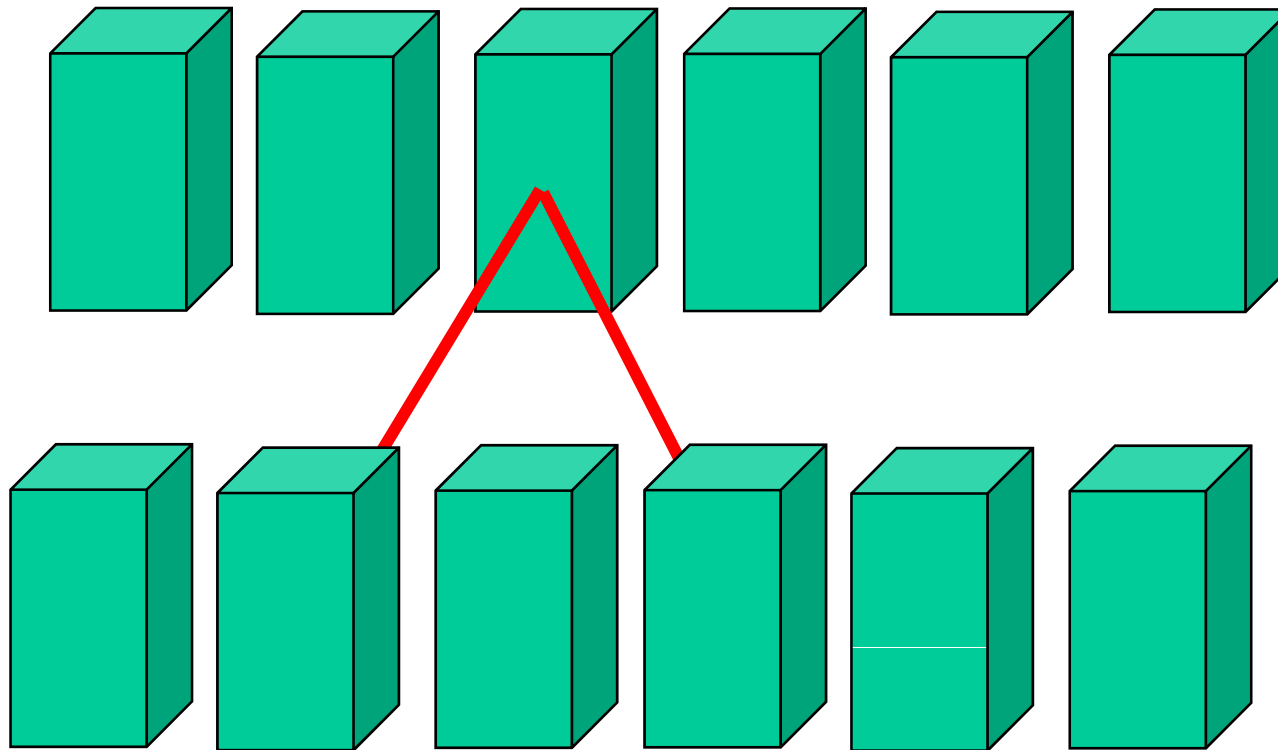

# Node Arrangements – Hexagonal Shape [5]

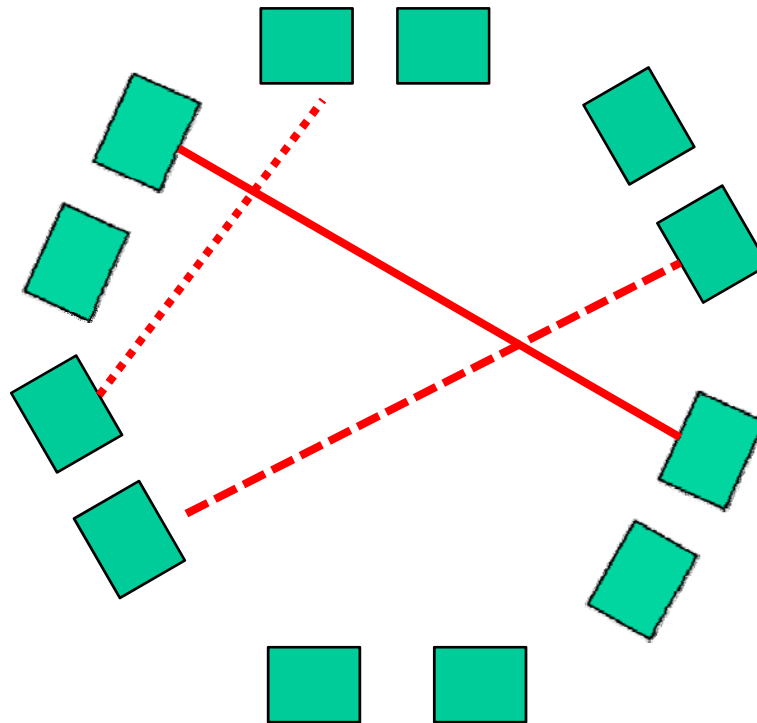

# Caley Data Center Design [12]

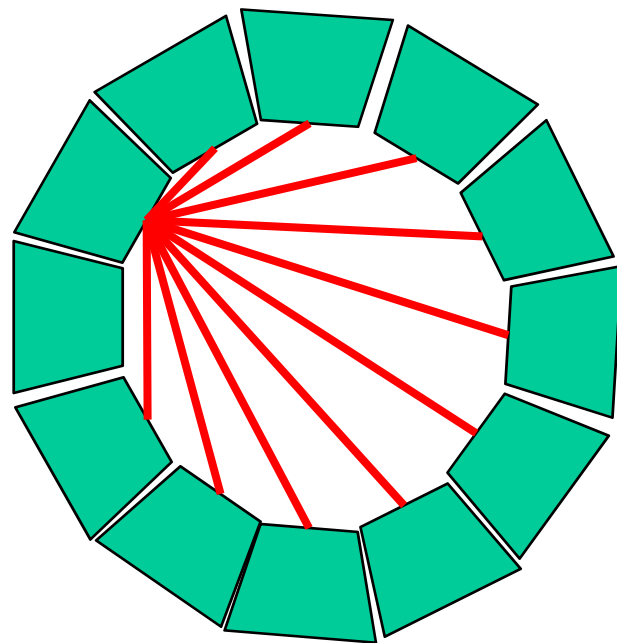

**Intra-Rack Links**

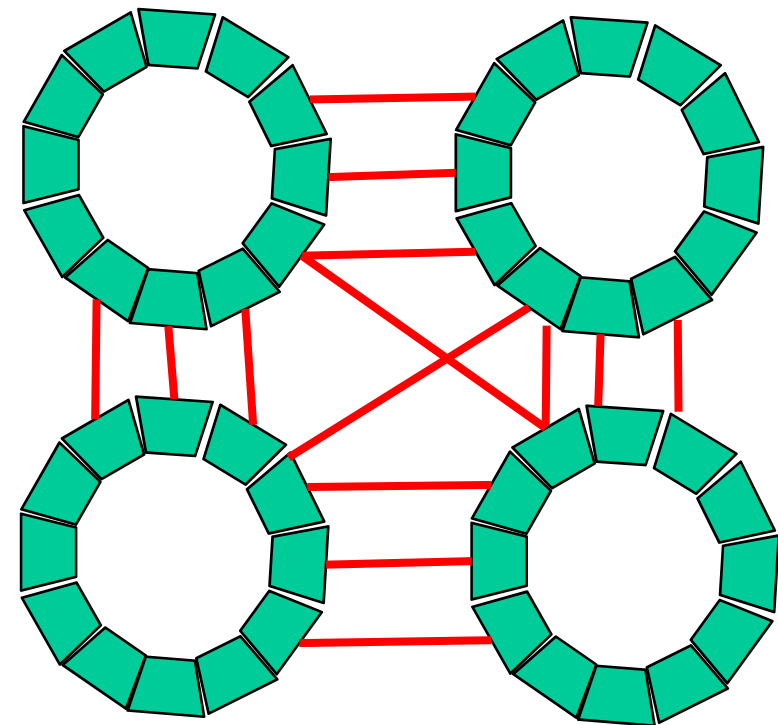

**Inter-Rack Links**

# Implications on other applications for THz Communications

- Standardization of a THz systems suitable for wireless data centers can pave the way for other applications, e.g. wireless backhauling and intra-device communication
- All these applications may be grouped together by a standard on „**Beam switchable wireless point-to-point 40/100 Gbps links**“
- Availability of cheaper CMOS technology will enable the adoption of the standard to nomadic mass-market applications, e. g. gaming

# Working towards a Study Group targeting wireless 10x Gbps ....

## Part IV: Investigating on which MAC to build on

-

# Comparison of the Standards

Capability	IEEE 802.3	IEEE 802.11n	IEEE 802.11ad	IEEE 802.15.3c
Access	Provided	Provided	Provided	Provided
Data transmission	Provided	Provided	Provided	Provided
Disassociation	Provided	Provided	Provided	Provided
Security	Not provided	Provided	Provided	Provided
Roaming	Not provided	Provided	Provided	Not provided
Power saving	Not provided	Provided	Provided	Provided
Channel estimation	Not provided	Provided	Provided	Provided
Adaptive modulation	Not provided	Provided	Provided	Provided
Beam control	Not provided	Not provided	Provided	Provided
Coexistence	Not provided	Provided	Provided	Not provided
Robustness	---	+++	+++	++
Overhead	+++	---	--	0

Provided

Not provided

Missing beam-forming support in 802.11n

802.15.3c preferable over 802.11ad due to lower overhead

802.3 appropriate for fixed links with stable, predefined conditions only; very low overhead



# Working towards a Study Group targeting wireless 10x Gbps ....

## Part V: Some thoughts on the PHY

-

# Principle Possibilities to achieve Wireless 10x Gbps

- Further development of 60 GHz systems by enhancing spectral efficiencies (15 bps/Hz to achieve 100 Gbps with 7 GHz bandwidth)
- Use FSO or IR solutions (eye safety, modulation and cost issues at least with some applications?)
- Use more spectrum and apply moderate spectral efficiencies => enough frequency spectrum available beyond 300 GHz only

# Working towards a Study Group targeting wireless 10x Gbps ....

## Part VI: Motion to form a Study Group

-

# Motion to form a Study Group

- At the July 2013 Plenary *The Terahertz Interest Group (IG THz) wished to start a study group with the scope of determining the validity of a standard on “100G (100 Gbit/s over beam switchable wireless point-to-point links)”*. Potential applications of interest include *wireless data centers, wireless intra-device communication, and wireless backhauling*. The wave length of interest for the PHY will be millimeter-wave or shorter. The recommendation of the study group will be to amend the *standard 802.15.3*.
- The SG has been approved by the EC

# Current Status of the Study Group

-

# Outcome of the 1st Meeting in Nanjing September 2013

- SG Leadership has been completed:
  - Chair: Thomas Kürner (TU Braunschweig)
  - Vice-Chair: Iwao Hosako (NICT)
  - Secretary: Cai Yunlong (Huawei)
  - Technical Editor: Rick Roberts (Intel)
- Press Release on the formation of the new study group has been discussed.
- Initial Working **Draft for PAR and 5C** have been created (Documents 15-13-0522-01-0thz and 15-13-0523-01-0thz, supporting Document 15-13-0561-01-0thz,)
- Work on the **Technical Expectation Document (TED)**“. The content of the TED has been discussed and updated (Document 15-11-0745-10-0thz)

# Joint Work with IEEE 802.1

- Looking at the targeted application Bridging is an issue
  - For sure in Wireless Data Centers
  - Potentially also in the wireless backhauling/fronthauling applications
- The development of a standard for wireless 100G puts us in a green field situation with the chance to consider bridging right from the beginning
- First item to discuss is the compatibility item in the 5C document.
  - Possible joint meeting at the Interim Meeting in January 2014

# Planned Time Line

- November 2013 Plenary:
- 1st joint meeting with 802.1
  
- January 2014 Interim:
- 2nd joint meeting 802.1
- Finishing complete draft PAR and 5C ready for WG approval and submission to EC
  
- March 2014 Plenary:
- Addressing comments and getting PAR and 5C done
  
- May 2014 Interim
- Potential Kick-off of a Task Group



# List of References (1/2)

- [1] H. J. Song et. al., „24 Gbit/s data transmission in 300 GHz band for future terahertz communications“, Electronic Letters, 1th July 2012, Vol. 48, No.15
- [2] I. Kallfass et. al., “All Active MMIC Based Wireless Communication at 220 GHz, "IEEE Trans. on Terahertz Science and Technology, vol. 1, no. 2, pp. 477-487, Nov. 2011
- [3] J. Antes et. al. ,”MMIC based wireless data transmission of a 12.5 Gbit/s signal using a 220 GHz carrier,"in Proc. European Microwave Integrated Circuit Conf., Manchester, pp. 238-241, 2011
- [4] Kaishun Wu, „Rethinking the architecture design of data center networks“, Front. Comp. Science, Review Article, 2012 (9 pages)
- [5] H. Vardhan, Wireless Data Center with Millimeter Wave Network, Proc. IEEE Goecom 2010
- [6] Katayama Y, Takano K, Kohda Y, Ohba N, Nakano, “Wireless data center networking with steered-beam mmwave links”, in: Proceeding of 2011 IEEE Wireless Communications and Networking Conference. 2011, pp. 2179–2184
- [7] Zhang W et. Al, „3D beamforming for wireless data centers“, in Proceedings of the 10th ACM Workshop on Hot Topics in Networks. 2011

## List of References (2/2)

- [8] D. Halperin et. al, „Augmenting Data Center Networks with Multi-Gigabit Wireless Links“, SIGCOMM 2011
- [9] „On the feasibility of Completely Wireless Data Centers“,  
<http://www.cs.cornell.edu/courses/cs6452/2012sp/papers/cayley.pdf>
- [10] K. Ramchadran, „60 GHz Data-Center Networking: Wireless Worry less?“, 2008
- [11] Y. Cui et. al, „ Channel Allocation in Wireless Data Center Networks“, IEEE INFOCOMM 2011
- [12] Y. Cui et. al, „ Wireless Link Scheduling for Data Center Networks“, ICUIMC'11, February 21-23, 2011, Seoul, Korea