

**Project: IEEE P802.15 Working Group for Wireless Personal Area Networks (WPANs)**

**Submission Title:** Proposed OFDM Resolutions for Comments of CIDs 400 through 416 of LB #87

**Date Submitted:** March, 2013

**Source:** Cheolho Shin (ETRI), Sangsung Choi (ETRI) and Soo-Young Chang (SYCA)

**Contact:** sychang@ecs.csus.edu

**Voice:** +1-530-574-2741 E-Mail: sychang@ecs.csus.edu

**Re:** [802.15 TG4m]

**Abstract:** This document provides proposed OFDM resolutions for CIDs 400 through 416 of LB#87.

**Purpose:** To provides proposed resolutions for LB#87

**Notice:** This document has been prepared to assist the IEEE P802.15. It is offered as a basis for discussion and is not binding on the contributing individual(s) or organization(s). The material in this document is subject to change in form and content after further study. The contributor(s) reserve(s) the right to add, amend or withdraw material contained herein.

**Release:** The contributor acknowledges and accepts that this contribution becomes the property of IEEE and may be made publicly available by P802.15.

## Comments for TVWS OFDM Issues

- CID 400
- CID 402
- CID 404
- CID 407/412/413/414/415
- CID 408
- CID 409/410/411
- CID 416

CS: R

# CID 400, 20.2.3.3, 73, Table 139

- Comment
  - The difference between similar mandatory and optional modulation modes is not clear in the table, e.g., what is the difference between MCS0 and MCS3; MCS1 and MCS4, and so on.
- Proposed Change
  - Please clarify and/or include additional information in table.
- Proposed Resolution
  - ***See Table 137***
  - ***MCSs 3-5 are 4 times overclock modes comparing to MCSs 0-2.***

# CID 402, 20.2.3.4, 73, 6

- Comment
  - Editorial: Figure 121 missing connections at taps in diagram.
- Proposed Change
  - Add connection dots or squares at cross taps. Do the same for other polynomial diagrams/figure throughout the draft.
- Proposed Resolution

*Modify Figure 121.*

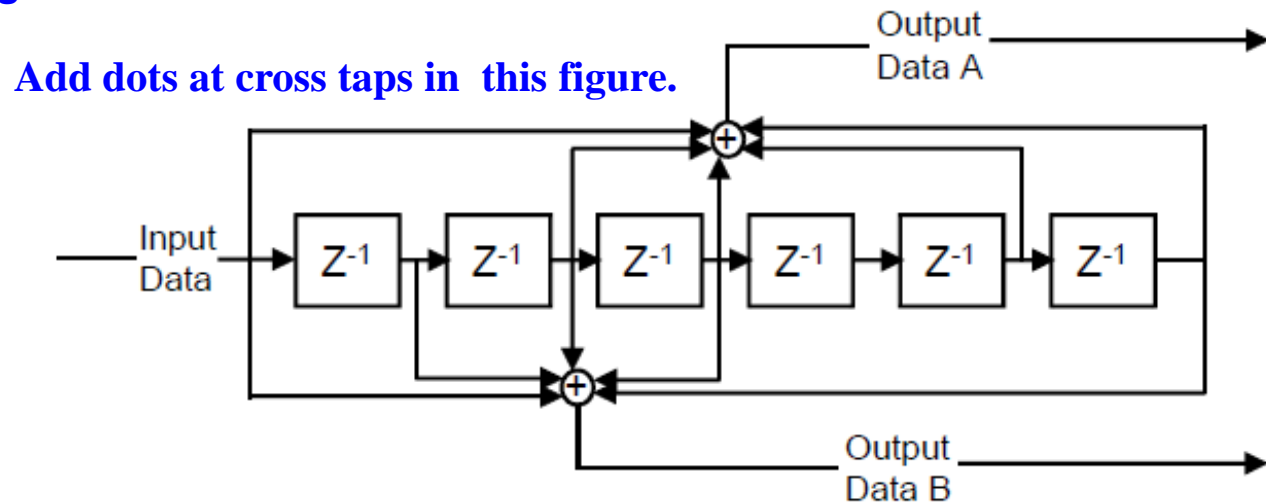

# CID 404, 20.2.3.4, 75, Fig. 122

- Comment
  - While the figure is useful in understanding the arrangement of tones in the signal, the location of the pilots is not very clear. It seems like the x-axis tone numbers imply pilot tone location, but then DC(tone 0) is also listed.
- Proposed Change
  - The figure needs to be properly labeled. Perhaps it would be best to include a table or text clarifying the location of the pilot tones.
- Proposed Resolution
  - *Modify Fig. 122: Remove “0” in the x-axis*
  - *Insert a table to clarify the location of the pilot tones.*
  - *Add the following sentence to clarify the data tones:*  
*“The data tones to be transmitted in the OFDM symbol are placed into the negative data tones (numbered from –64 to –1) followed by the positive data tones (numbered 1 to 64).”*

CS: R

# CID 407/412/413/414/415, 20.2.4.1, 77, 27

- Comment

- (407) Table 4ic references frequency bands not allocated to TVWS.
- (412) The 4m PAR states: This amendment specifies a physical layer for 802.15.4 meeting TV white space regulatory requirements in as many regulatory domains as practical and also any necessary Media Access Control (MAC) changes needed to support this physical layer. The amendment enables operation in the VHF/UHF TV broadcast bands between 54 MHz and 862 MHz, supporting typical data rates in the 40 kbits per second to 2000 kbits per second range, to realize optimal and power efficient device command and control applications. Why the TVWS -OFDM PHY also operates in the 4g bands?
- (413/414/415) The TVWS -OFDM PHY should operate only in TVWS bands and not in 4g bands. Why 4m TVWS-OFDM amends the 4g MR-OFDM PHY layer? 4m PAR clearly states: This amendment specifies a physical layer for 802.15.4 meeting TV white space regulatory requirements in as many regulatory domains as practical and also any necessary Media Access Control (MAC) changes needed to support this physical layer. The amendment enables operation in the VHF/UHF TV broadcast bands between 54 MHz and 862 MHz, supporting typical data rates in the 40 kbits per second to 2000 kbits per second range, to realize optimal and power efficient device command and control applications.

**CS: R**

# CID 407/412/413/414/415, 20.2.4.1, 77, 27 (cont'd)

- Proposed Change
  - (407) Rows indicting bit numbers 5 - 18 are not bands that were allocated for analogue VHF / UHF TV broadcast. Either justify the inclusion or remove from the supported band fields.
  - (412/ 413/414/415) Remove 4g bands from the bands where TVWS-OFDM PHY operates.
- Proposed Resolution

*Refer to the resolutions for CIDs 152, 154, and 369.*

# CID 408, 20.2.4.2, 77, 31

- Comment
  - Consider whether performance improvements can be achieved when filter characteristics are further specified.
- Proposed Change
  - see comment.
- Proposed Resolution
  - Refer to a document, 15-13-0176-00-004m-proposed-resolution-to-cid-408-of-lb-87.*



**CS: AP**

# CID 409/410/411, 20.2.4.2, 77, 31-32

- Comment
  - Pulse shaping method is not defined in this chapter.
- Proposed Change
  - Give a definition of the pulse shaping.
- Proposed Resolution
  - Refer to a document, 15-13-0176-00-004m-proposed-resolution-to-cid-408-of-lb-87.*

# CID 416, 20.2.4, 77

- Comment
  - TVWS-OFDM PHY has an incomplete specification of RF requirements.
- Proposed Change
  - One can assume that these requirements would be worked into the draft over time. Please include a list of the specifications that would be specified by the standard. Include RF requirements that are known.
- Proposed Resolution
  - Modify the text. (Will provide the text later.)*