

IEEE P802.15
Wireless Personal Area Networks

Project	IEEE P802.15 Working Group for Wireless Personal Area Networks (WPANs)	
Title	Task Group 15.4m OFDM Merged Text Proposal	
Date Submitted	September 13, 2012	
Source	Soo-Young Chang (CSUS), Cheol-ho Shin , Mi-Kyung Oh, and Sangsung Choi (ETRI), Hiroshi Harada, Fumihide Kojima, Ryuhei Funada, Alina Lu Liru, Ming-Tuo Zhou, Zhou Lan, and Chin-Sean Sum(NICT), Cristina Seibert (SSN), Jeritt Kent (ADI), Khurram Waheed (Freescale), and Shigenobu Sasaki, Takuya Inoko, Yutaro Fukaishi, Hiromu Niwano and Bingxuan Zhao (Niigata University)	E-mail: [sychang@ecs.csus.edu]
Re:	Merger work for TVWS OFDM PHY from four OFDM PHY proposals presented in July 2012 meeting and inputs from all proposers	
Abstract	15.4m merged text proposal draft for TVWS OFDM PHY prepared by the OFDM PHY merger group consisting of all 15.4m PHY proposers	
Purpose	To provide the baseline document for drafting the standard	
Notice	This document has been prepared to assist the IEEE P802.15. It is offered as a basis for discussion and is not binding on the contributing individual(s) or organization(s). The material in this document is subject to change in form and content after further study. The contributor(s) reserve(s) the right to add, amend or withdraw material contained herein.	
Release	The contributor acknowledges and accepts that this contribution becomes the property of IEEE and may be made publicly available by P802.15.	

20.2 TVWS-OFDM PHY Specification

The TVWS orthogonal frequency division multiplexing (TVWS-OFDM) PHY supports data rates ranging from 390.625kb/s to 1562.5kb/s. The subcarrier spacing is equal to 1250/128 KHz.

The symbol rate is 7.8125ksymbol/sec, which corresponds to 128 μ s per symbol. This symbol includes a quarter-duration cyclic prefix (CP; 25.6 μ s) and a base symbol (102.4 μ s).

20.2.1 PPDU format for TVWS-OFDM

The TVWS-OFDM PPDU shall be formatted as illustrated in Figure 128.

Number of OFDM symbols					
Variable (1 – 4)	2	1	Variable	6 bit	Variable
STF	LTF	PHR	PSDU	TAIL	PAD
SHR		PHY Header	PHY payload		

Figure 128 - Format of the TVWS-OFDM PPDU

The synchronization header (SHR), PHY header (PHR), and PHY payload components are treated as bit strings of length n , numbered b_0 on the left and b_{n-1} on the right. When transmitted, they are processed b_0 first to b_{n-1} last, without regard to their content of structure.

Definitions are provided in the frequency domain for the Short Training field (STF) in 20.2.1.1 and for the Long Training field (LTF) in 20.2.1.2. In each case, a normative set of operations is specified to transform the frequency domain fields to the time domain and to insert prescribed repetitions or CPs of these time domain sequences.

The DATA field is composed of the PSDU, tail bits, and pad bits, as described in 20.2.3.4. The PPDU Tail Bit field (TAIL) is described in 20.2.3.8. The method for adding pad bits (PAD) is described in 20.2.3.9.

20.2.1.1 Short Training field (STF)

Subclauses 20.2.1.1.1 through 20.2.1.1.4 describe the STF.

20.2.1.1.1 Frequency domain STF

The frequency domain representation of the STF is defined by Table 140.

Table 140 - Frequency domain representation of STF

Tone #	Value	Tone #	Value	Tone #	Value	Tone #	Value
-64	0	-32	$\sqrt{2}+\sqrt{2}j$	0	0	32	$\sqrt{2}+\sqrt{2}j$
-63	0	-31	0	1	0	33	0
-62	0	-30	0	2	0	34	0
-61	0	-29	0	3	0	35	0

-60	0	-28	0	4	0	36	0
-59	0	-27	0	5	0	37	0
-58	0	-26	0	6	0	38	0
-57	0	-25	0	7	0	39	0
-56	0	-24	$-\sqrt{2}-\sqrt{2}j$	8	$-\sqrt{2}-\sqrt{2}j$	40	$\sqrt{2}+\sqrt{2}j$
-55	0	-23	0	9	0	41	0
-54	0	-22	0	10	0	42	0
-53	0	-21	0	11	0	43	0
-52	0	-20	0	12	0	44	0
-51	0	-19	0	13	0	45	0
-50	0	-18	0	14	0	46	0
-49	0	-17	0	15	0	47	0
-48	$\sqrt{2}+\sqrt{2}j$	-16	$-\sqrt{2}-\sqrt{2}j$	16	$-\sqrt{2}-\sqrt{2}j$	48	$\sqrt{2}+\sqrt{2}j$
-47	0	-15	0	17	0	49	0
-46	0	-14	0	18	0	50	0
-45	0	-13	0	19	0	51	0
-44	0	-12	0	20	0	52	0
-43	0	-11	0	21	0	53	0
-42	0	-10	0	22	0	54	0
-41	0	-9	0	23	0	55	0
-40	$-\sqrt{2}-\sqrt{2}j$	-8	$\sqrt{2}+\sqrt{2}j$	24	$\sqrt{2}+\sqrt{2}j$	56	0
-39	0	-7	0	25	0	57	0
-38	0	-6	0	26	0	58	0
-37	0	-5	0	27	0	59	0
-36	0	-4	0	28	0	60	0
-35	0	-3	0	29	0	61	0
-34	0	-2	0	30	0	62	0
-33	0	-1	0	31	0	63	0

20.2.1.1.2 Time domain STF generation

Given a sequence of 128 samples, $f(n)$, indexed by $n = 0, \dots, 127$, the discrete Fourier transform (DFT) is defined as $F(k)$, where $k = 0, \dots, 127$:

$$F(k) = \frac{1}{\sqrt{128}} \sum_{n=0}^{127} f(n) e^{-j2\pi kn/128}$$

The sequence $f(n)$ can be calculated from $F(k)$ using the inverse discrete Fourier transform (IDFT), where the k values numbered from 0 to 63 correspond to tones numbered from 0 to 63 and the k values numbered from 64 to

127 correspond to tones numbered from -64 to -1, respectively:

$$f(n) = \frac{1}{\sqrt{128}} \sum_{k=0}^{127} F(k) e^{j2\pi nk/128}$$

The time domain STF is obtained as follows:

$$\text{STF}_{\text{time}} = \text{IDFT}(\text{STF}_{\text{freq}})$$

The CP is then prepended to the OFDM symbol.

20.2.1.1.3 Time domain STF repetition

The STF is repeated eight times per STF symbol and the CP is also 1/4 symbol. Therefore, there are 10 repetitions of 1/8 STF symbol in each STF OFDM symbol. The number of STF OFDM symbols varies from 1 to 4 as shown in Figure 128.

Figure 129 shows the STF structure. Each "s" in the figure represents one time-domain repetition of a subsequence of TVWS-OFDM.

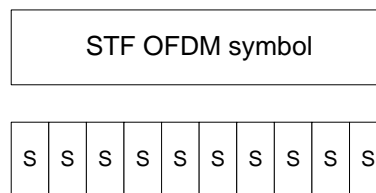

Figure 129 - Structure of STF OFDM symbol

20.2.1.1.4 STF power boosting

Power boosting shall be applied to the STF OFDM symbols in order to aid preamble detection, The boost should be a multiplication by **TBD**, which is approximately **TBD** dB.

20.2.1.2 Long Training field (LTF)

The LTF structure in both frequency and the time domain is described in 20.2.1.2.1 through 20.2.1.2.2.

20.2.1.2.1 Frequency domain LTF

Table 141 shows the frequency domain representation of the LTF.

Table 141 - Frequency domain representation of LTF: **TBD**

Tone #	Value	Tone #	Value	Tone #	Value	Tone #	Value
-64		-32		0		32	
-63		-31		1		33	
-62		-30		2		34	

-61		-29		3		35	
-60		-28		4		36	
-59		-27		5		37	
-58		-26		6		38	
-57		-25		7		39	
-56		-24		8		40	
-55		-23		9		41	
-54		-22		10		42	
-53		-21		11		43	
-52		-20		12		44	
-51		-19		13		45	
-50		-18		14		46	
-49		-17		15		47	
-48		-16		16		48	
-47		-15		17		49	
-46		-14		18		50	
-45		-13		19		51	
-44		-12		20		52	
-43		-11		21		53	
-42		-10		22		54	
-41		-9		23		55	
-40		-8		24		56	
-39		-7		25		57	
-38		-6		26		58	
-37		-5		27		59	
-36		-4		28		60	
-35		-3		29		61	
-34		-2		30		62	
-33		-1		31		63	

20.2.1.2.2 Time domain LTF generation

The time domain LTF is obtained as follows:

$$LTF_{\text{time}} = \text{IDFT}(LTF_{\text{freq}})$$

A 1/2 symbol CP is prepended to two consecutive copies of the base symbol as shown in Figure 130. For more details, see 20.2.3.8.

The time-domain LTF structure is shown in Figure 130, where T_{DFT} is the duration of the base symbol.

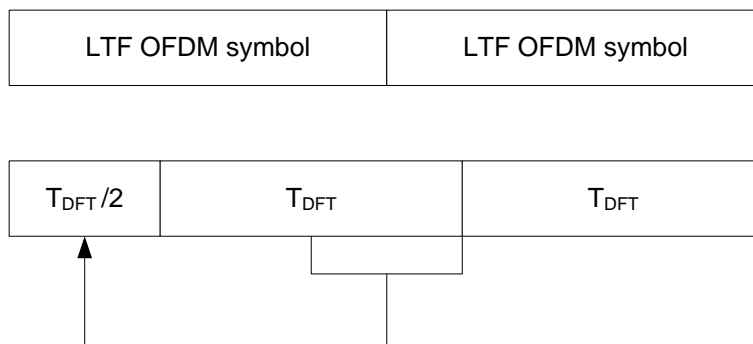

Figure 130-Structure of LTF for TVWS-OFDM

20.2.1.3 PHR

The PHR consists of the Frame Length field and frame control bits. The PHR structure shall be formatted as illustrated in Figure 131. All multi-bit fields are unsigned integers and shall be processed MSB first.

Bit string index	0-5	6-7	8-18	19-27	28-43	44-49
Bit mapping	R_5-R_0	RA_1-RA_0	$L_{10}-L_0$	S_8-S_0	$H_{15}-H_0$	T_5-T_0
Field name	Reserved	Rate	Frame Length	Scrambling seed	HCS	Tail

Figure 131- PHY header fields for TVWS-OFDM

The PHR occupies one OFDM symbol. The PHR shall be transmitted using the lowest supported modulation and coding scheme (MCS) level, as described in Table 142. It is sent to the convolutional encoder starting from the leftmost bit in Figure 131 to the rightmost bit.

The Rate field (RA_1-RA_0) specifies the data rate of the payload and is equal to the numerical value of the MCS for the mandatory mode and the numerical value of the MCS minus three for the optional 4 times overclock modes, as described in 20.2.2, expressed in binary format. The list of data rates for TVWS-OFDM can be found in 20.2.2.

The Frame Length field ($L_{10}-L_0$) specifies the total number of octets contained in the PSDU (prior to FEC encoding).

The Scrambler field (S_8-S_0) specifies the scrambling seed defined by the manufacturer.

The Header Check Sequence (HCS) field ($H_{15}-H_0$) is a 16-bit CRC taken over the PHY header (PHR) fields.

The HCS shall be computed using the first 28 bits of the PHR. The HCS shall be calculated using the polynomial, $G_{16}(x) = x^{16} + x^{12} + x^5 + 1$.

At the transmitter, the initial remainder of the division shall be preset to all ones and then be modified via division of the calculation field by the generator polynomial, $G_{16}(x)$. The one's complement of this remainder is the HCS field.

The Tail bit field (T_5-T_0), which consists of all zeros, is for Viterbi decoder flushing, as described in 20.2.3.8.

All reserved fields shall be set to zero upon transmission and shall be ignored upon reception.

20.2.1.4 PSDU field

The PSDU field carries the data of the PHY packet.

20.2.2 Data rates for TVWS-OFDM

All devices shall support all BPSK, QPSK and 16-QAM (Quadrature Amplitude Modulation) and coding scheme levels (MCS0-2). All 4 times overlock modes (MCS3-5) are optional.

The various data rates are shown in Table 142. The nominal bandwidth is calculated by multiplying {the number of active tones + 1 for the DC tone} by {the subcarrier spacing}.

Table 142-Data Rates for TVWS-OFDM PHY

Parameter	Mandatory Modes	Optional Modes
Nominal bandwidth (kHz)	1064.5	4258
Subcarrier spacing (kHz)	1250/128	4*1250/128
DFT size	128	128
Active tones	108	108
# Pilot tones	8	8
# Data tones	100	100
MCS0 (kb/s) (BPSK rate 1/2)	390.625	
MCS1 (kb/s) (QPSK rate 1/2)	781.250	
MCS2 (kb/s) (16-QAM rate 1/2)	1562.5	
MCS3 (kb/s) (BPSK rate 1/2)		1562.5
MCS4 (kb/s) (QPSK rate 1/2)		3125
MCS5 (kb/s) (16-QAM rate 1/2)		6250

20.2.3 Modulation and coding for TVWS-OFDM

20.2.3.1 Reference modulator diagram

The reference modulator diagram is shown in Figure 132.

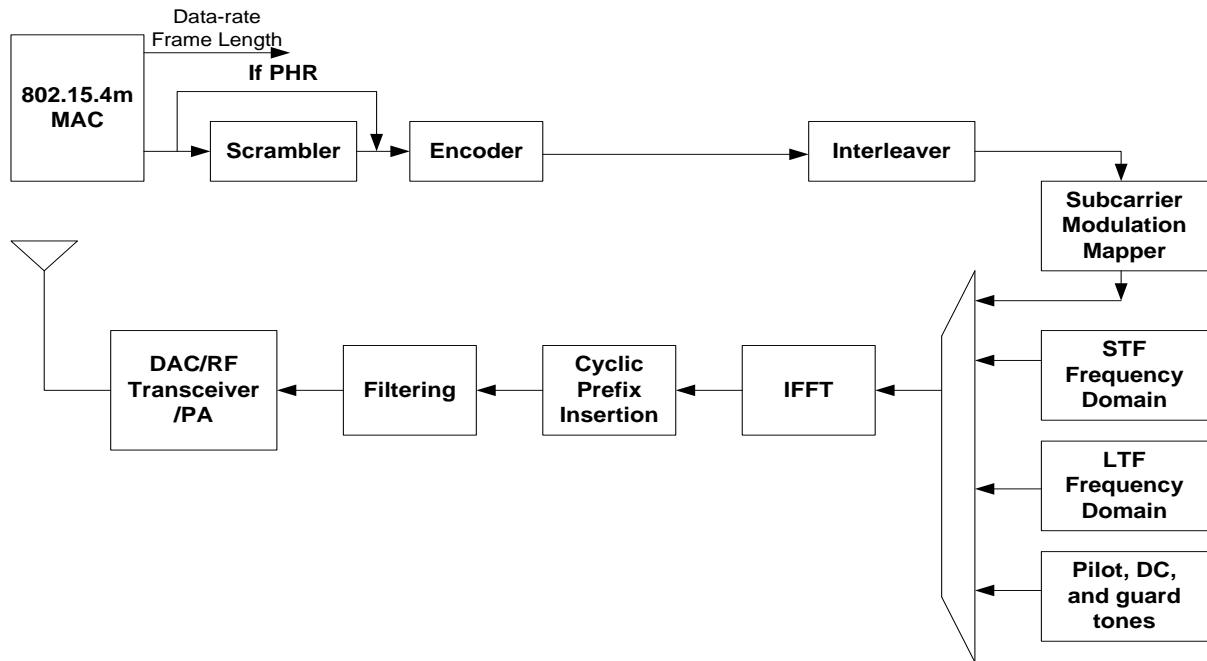

Figure 132-Reference modulator diagram for TVWS-OFDM

20.2.3.2 Bit-to-symbol mapping

Figure 133 shows the bit-to-symbol mapping for BPSK, QPSK, and 16-QAM.

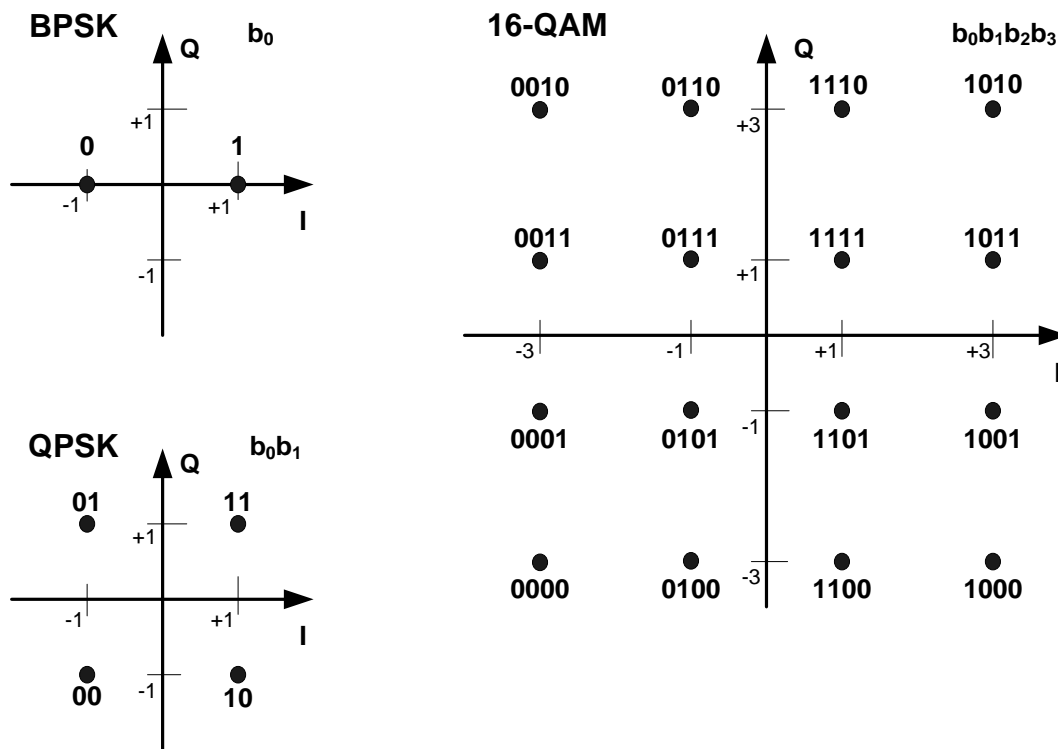

Figure 133-Bit-to-symbol mapping for TVWS-OFDM

The output values, d , are formed by multiplying the resulting $(I + jQ)$ value by a normalization factor K_{MOD} :

$$d = (I + jQ) \times K_{MOD}$$

The normalization factor, K_{MOD} , depends on the base modulation mode, as described in Table 143. The purpose of the normalization factor is to achieve the same average power for all mappings.

Table 143-Modulation-dependent normalization factor K_{MOD}

Modulation	K_{MOD}
BPSK	1
QPSK	$1/\sqrt{2}$
16-QAM	$1/\sqrt{10}$

20.2.3.3 PIB attribute values for *phySymbolsPerOctet*

The number of symbols per octet depends on both the MCS level and the OFDM option, as represented in Table 144.

Table 144- *phySymbolsPerOctet* values for TVWS-OFDM PHY

Parameter	Mandatory Modes	Optional Modes
MCS0 (BPSK rate 1/2)	8 bits/octet * 1/50 symbol/bits	
MCS1 (QPSK rate 1/2)	8 bits/octet * 1/100 symbol/bits	
MCS2 (16-QAM rate 1/2)	8 bits/octet * 1/200 symbol/bits	
MCS3 (BPSK rate 1/2)		8 bits/octet * 1/50 symbol/bits
MCS4 (QPSK rate 1/2)		8 bits/octet * 1/100 symbol/bits
MCS5 (16-QAM rate 1/2)		8 bits/octet * 1/200 symbol/bits

20.2.3.4 Forward error correction (FEC)

The DATA field shall be coded with a convolutional encoder of coding rate $R = 1/2$. The convolutional encoder shall use the generator polynomials expressed in octal representation, $g_0 = 133_8$ and $g_1 = 171_8$, as shown in Figure 134. The convolutional encoder shall be initialized to the all zeros state before encoding the PHR and then reset to the all zeros state before encoding the PSDU.

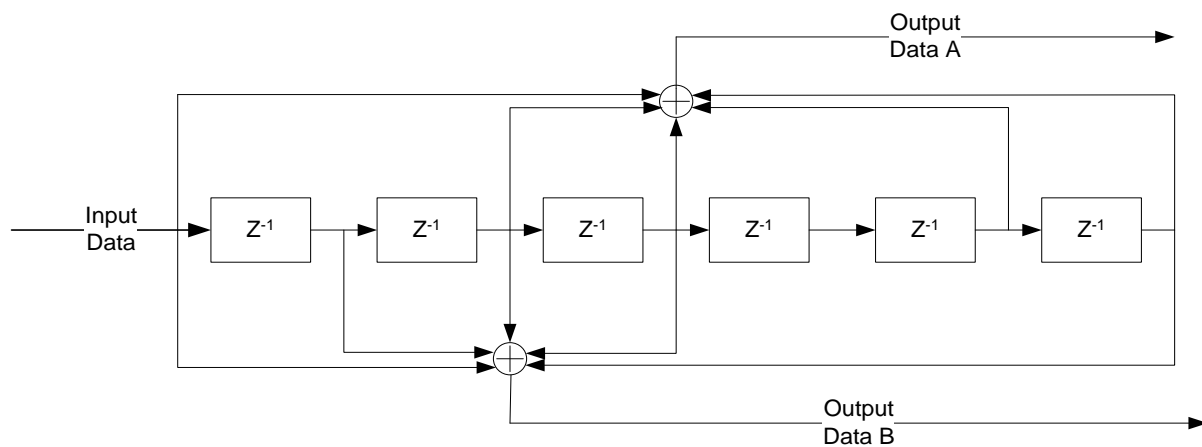

Convolutional Encoder: Rate $1/2$, constraint length $K=7$
Octal generator polynomials [133, 171]

Figure 134-Rate 1/2 convolutional encoder

20.2.3.5 Interleaver

The interleaving process consists of two permutations. The index of the coded bit before the first permutation shall be denoted as k ; i shall be the index after the first and before the second permutation; and j shall be the index after the second permutation, just prior to modulation mapping. The coded bits are written at the index given by j , and read out sequentially. The index i is defined as follows:

$$i = \left(\frac{N_{\text{cbps}}}{N_{\text{row}}} \right) \times [k \bmod(N_{\text{row}})] + \text{floor}\left(\frac{k}{N_{\text{row}}}\right)$$

where

- N_{cbps} is the number of coded bits per symbol,
- k is 0, 1, 2, ..., $(N_{\text{cbps}} - 1)$, and
- N_{row} is 20.

The index j is defined as follows:

$$j = s \times \text{floor}\left(\frac{i}{s}\right) + \left[i + N_{\text{cbps}} - \text{floor}\left(\frac{N_{\text{row}} \times i}{N_{\text{cbps}}}\right) \right] \bmod(s)$$

where

- N_{cbps} is the number of coded bits per symbol,
- i is 0, 1, 2, ..., $(N_{\text{cbps}} - 1)$, and
- N_{row} is 20,

and

$$s = \max\left(\frac{N_{\text{bpsc}}}{2}, 1\right),$$

where N_{bpsc} is the number of bits per subcarrier, and has the values 1, 2, and 4 for BPSK, QPSK, and 16-QAM, respectively. N_{cbps} is defined as follows: 100 bits for BPSK, 200 bits for QPSK, and 400 bits for 16-QAM.

20.2.3.6 Pilot tones / null tones

The numbers of pilot and null tones for TVWS are defined as shown in Table 145.

Table 145-Numbers of pilot and null tones for TVWS-OFDM PHY

Parameter	Mandatory Modes	Optional Modes
Active tones	108	108
# Pilot tones	8	8
# Data tones	100	100
# DC null tones	1	1

The DC tone is numbered as 0 and the subcarriers for pilot and data tones are numbered as -54 to 54 with the DC tone unused as depicted by Figure 135.

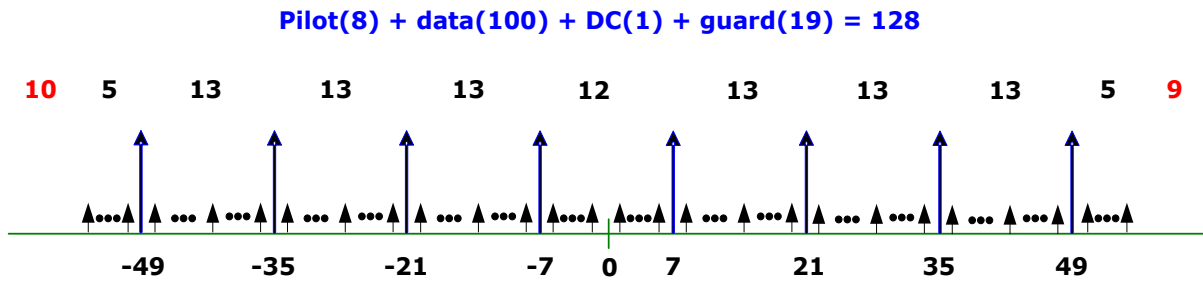

Figure 135 - Pilot tones for TVWS OFDM

The data carried on the pilot tones shall be determined by a pseudo-noise sequence PN9 with the seed “11111111”. The first output bit is assigned to the most negative index in pilot tones. For example, the first output bit from the PN9 sequence is assigned to the pilot symbol with index -49 and the second output bit is assigned to the pilot symbol with index -35. Table 146 shows the mapping from PN9 bits to the pilot BPSK symbols for all MCS levels. Index n starts after the LTF from zero and is increased by for one every pilot subcarrier.

Table 146-Mapping from PN9 sequence to pilot BPSK symbols

Input bit(PN9 _n)	BPSK Symbol
0	-1
1	1

20.2.3.7 Cyclic prefix

For the STF, the CP is defined in 20.2.1.1.3. For the LTF, the CP is defined in 20.2.1.2.2. For the remaining OFDM symbols, a CP shall be prepended to each base symbol. The duration of the CP (25.6 μs) shall be 1/4 of the base symbol (102.4 μs). The CP is a replication of the last 25.6 μs of the base symbol. The CP is illustrated in Figure 136.

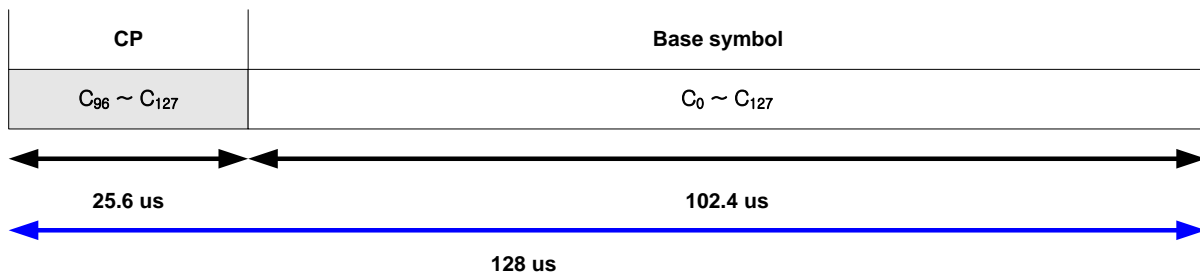

Figure 136-Cyclic prefix (CP)

20.2.3.8 PPDU Tail Bit field (TAIL)

The PPDU tail bit field shall be six bits of “0,” which are required to return the convolutional encoder to the “zero state.” This procedure reduces the error probability of the convolutional decoder, which relies on future bits when decoding and which may not be available past the end of the message. The PPDU tail bit field shall be produced by replacing six scrambled “zero” bits following the message end with six nonscrambled “zero” bits.

20.2.3.9 Pad bits (PAD)

The number of bits in the DATA field shall be a multiple of N_{cbps} . To achieve that, the length of the message is extended so that it becomes a multiple of N_{dbps} , the number of data bits per OFDM symbol. At least six bits are appended to the message, in order to accommodate the tail bits, as described in 20.2.3.8. The number of OFDM symbols, N_{SYM} , the number of bits in the DATA field, N_{DATA} , and the number of pad bits, N_{PAD} , are computed from the length, in octets, of the PSDU (LENGTH is equal to the content of the Frame Length field in Figure 131) as follows:

$$N_{\text{dbps}} = N_{\text{cbps}} \times \text{coding rate}(R)$$

$$N_{\text{SYM}} = \text{ceiling}[8 \times \text{LENGTH} + 6)/N_{\text{dbps}}]$$

$$N_{\text{DATA}} = N_{\text{SYM}} \times N_{\text{dbps}}$$

$$N_{\text{PAD}} = N_{\text{DATA}} - (8 \times \text{LENGTH} + 6)$$

The function ceiling() returns the smallest integer value greater than or equal to its argument value. The appended bits (i.e., pad bits) are set to “zeros” and are subsequently scrambled with the rest of the bits in the DATA field.

In the case of the PHR, the number of bits in the DATA field shall be set to 50 as in 20.2.1.3.

20.2.3.10 Scrambler and scrambler seeds

The input to the scrambler is the data bits followed by tail bits and then pad bits. The scrambler uses a PN9 sequence that is shown in Figure 137. The PN9 scrambler is initialized by the scrambling seed specified by 9 bits in the PHR, as shown in Figure 131. The leftmost value of the scrambling seed is placed into the leftmost delay element in Figure 137.

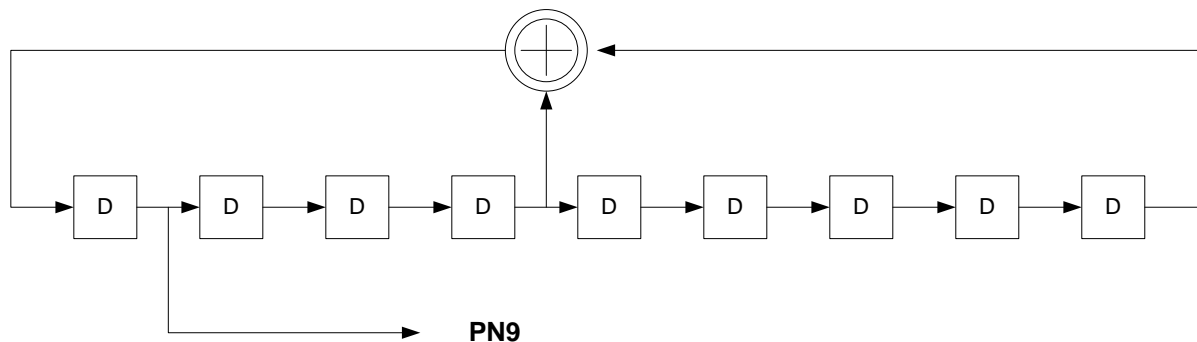

Figure 137 - Schematic of the PN9 sequence generator

The PN9 generator shall be reinitialized to the seed after each packet (either transmit or receive). The PN9 generator is clocked using the seed as the starting point and enabled after the first clock cycle. For example, for the seed in the PN9 generator of all ones as “111111111,” the first 30 bits out of the PN9 generator, once it is enabled, would be as follows:

$PN9_n = 0_0, 0_1, 0_2, 0_3, 1_4, 1_5, 1_6, 1_7, 0_8, 1_9, 1_{10}, 1_{11}, 0_{12}, 0_{13}, 0_{14}, 0_{15}, 1_{16}, 0_{17}, 1_{18}, 1_{19}, 0_{20}, 0_{21}, 1_{22}, 1_{23}, 0_{24}, 1_{25}, 1_{26}, 0_{27}, 1_{28}, 1_{29}$.

The scrambled bits are found using an XOR operation of each of the input bits with the PN9 sequence:

$$\text{bit}_n = (\text{input bit}_n) \text{ XOR } (PN9_n)$$

After scrambling, the tail bits are reset to all zeros.

20.2.3.11 Pulse Shaping

Pulse shaping is applied at the transmitter. The pulse shaping method is as needed to meet regulatory requirements in the band of operation.