

Project: IEEE P802.15 Working Group for Wireless Personal Area Networks (WPANs)

Submission Title: Data transmission at 2.5 Gb/s with THz and IR Signals through Fog

Date Submitted: 8 November, 2011

Source: Lothar Moeller, Alcatel-Lucent

Address 791 Holmdel-Keyport Rd, Holmdel, 07733, NJ, USA

Voice:+1 732 888 7237, FAX: +1 732 888 7074, E-Mail: lothar.moeller@alcatel-lucent.com

Abstract: We demonstrate weather impact on THz and IR links

Purpose: Invited presentation given at meeting

Notice: This document has been prepared to assist the IEEE P802.15. It is offered as a basis for discussion and is not binding on the contributing individual(s) or organization(s). The material in this document is subject to change in form and content after further study. The contributor(s) reserve(s) the right to add, amend or withdraw material contained herein.

Release: The contributor acknowledges and accepts that this contribution becomes the property of IEEE and may be made publicly available by P802.15.

Data transmission at 2.5 Gb/s with THz and IR Signals through Fog

Lothar Moeller

Bell Laboratories / Alcatel-Lucent
lothar.moeller@alcatel-lucent.com

Ke Su, John Federici
New Jersey Institute of Technology

IEEE 802, November 8, 2011

Talk Outline

- Setup for 2.5 Gb/s @ 625 GHz signaling
- 2.5 Gb/s IR link design
- Fog generation and characterization
- Studying fog impact on THz/IR links
- Conclusions

Three main industrial appl's for THz technology

Focus on THz communications as fast growing research area with big potential for commercial applications

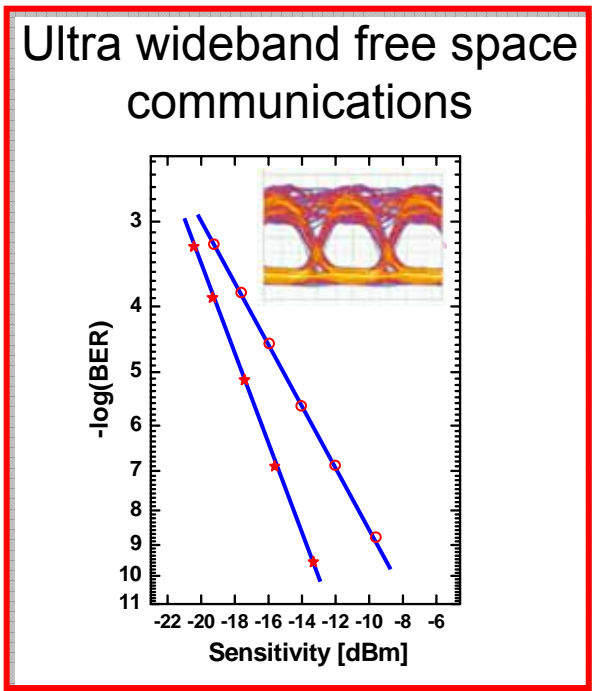

Non Destructive Evaluation



Imaging and Spectroscopy

Security Scanning



Detecting concealed weapons

THz Communication demonstrated with electrical and optoelectronic signal processing

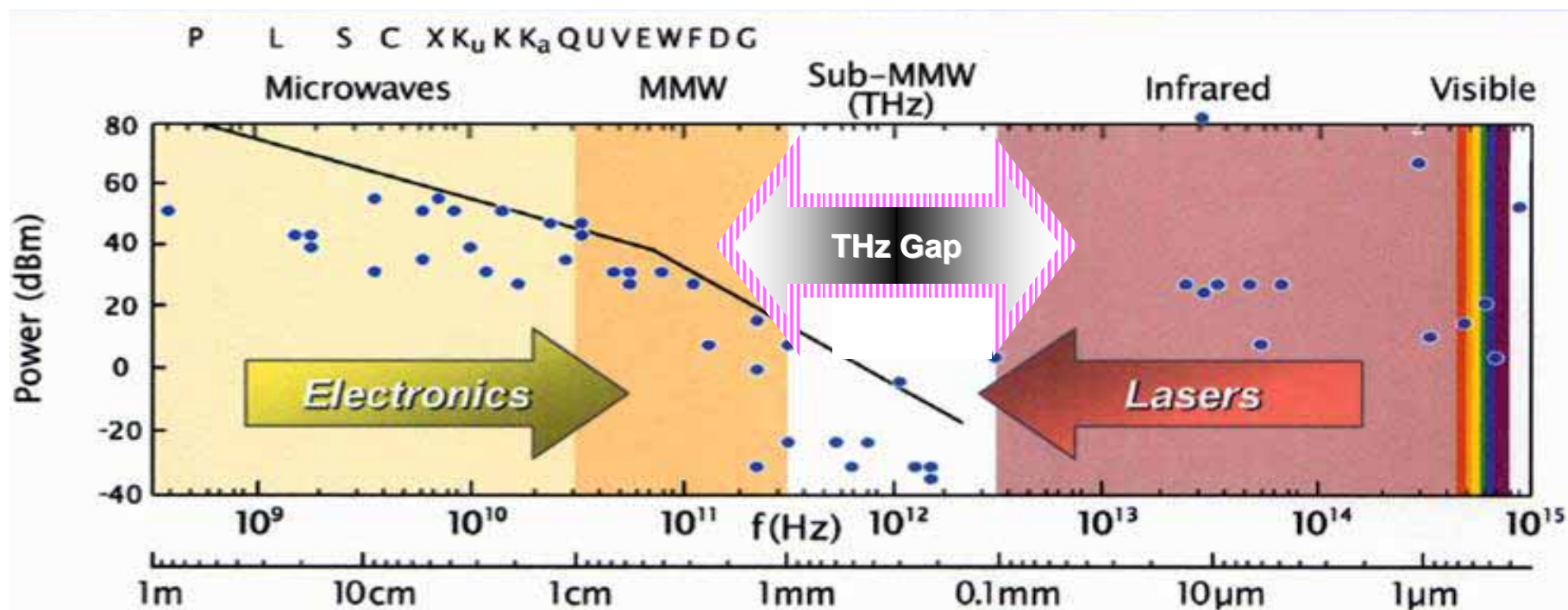

- Fully electronic approaches can have cost and SWAP advantages.
- Optoelectronic setups allow to cover full THz spectral range.

THz communications in future:

Modulation, detection and applications of ultra-high speed wireless data signals on THz carriers

$$f_{carrier} > 100 \text{ GHz} \quad \& \quad R \leq 100 \text{ Gb/s}$$

- Reliable communication under different weather conditions.
- Potential for ultra-high capacity links.
- Secure signaling (technology advantage), high directivity.
- Regulations for THz frequency bands need to be established.

Simulated THz beams outperform IR links in fog

Current research focus on experimental studies of weather impact on THz and IR links

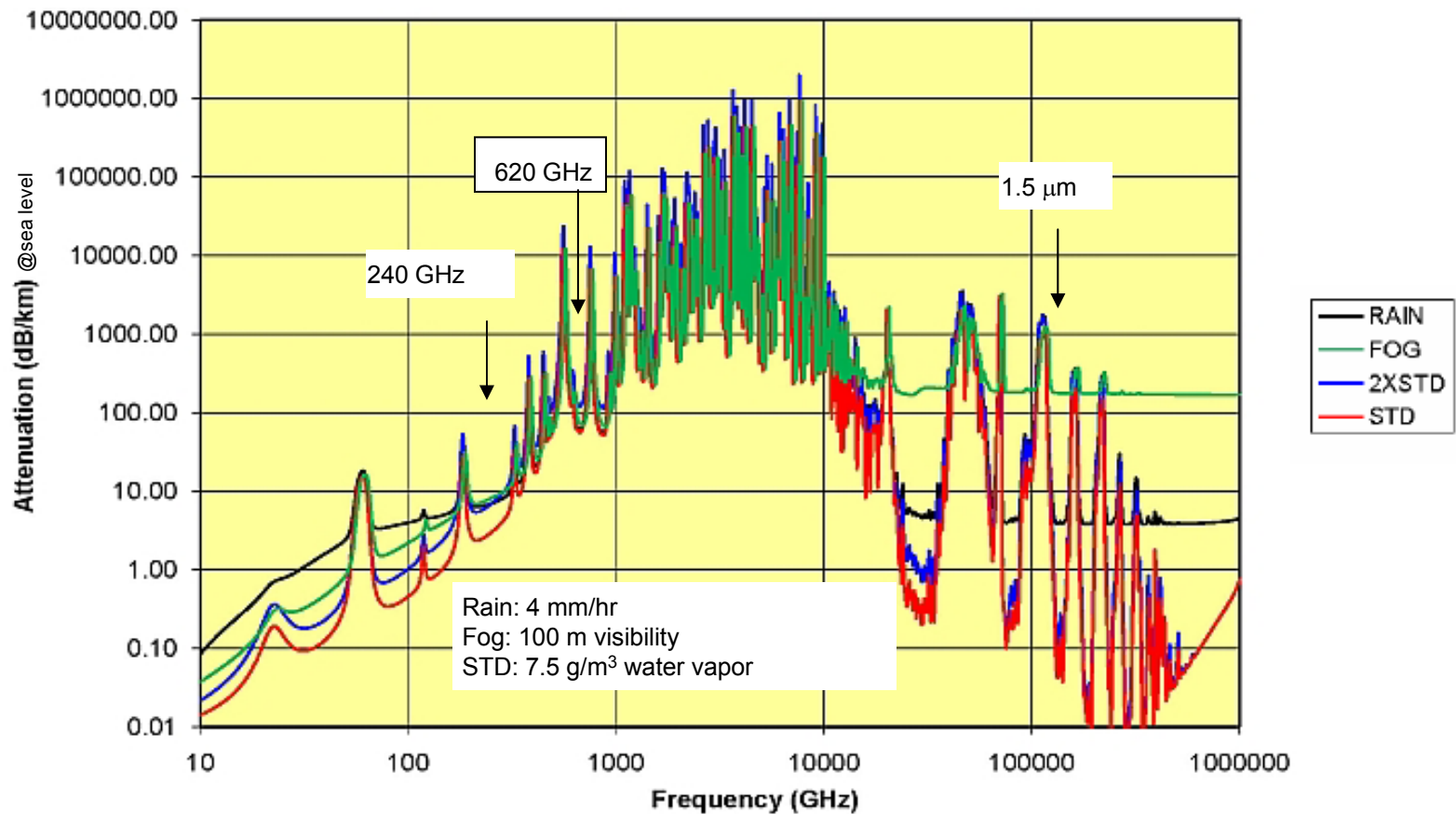

Simulated attenuation in foggy air (www.mmwconcept.com):
T-rays @ 240 GHz ~8dB/km, IR ~200dB/km

Frequency bands of 2.5 Gb/s @ 625 GHz experiment

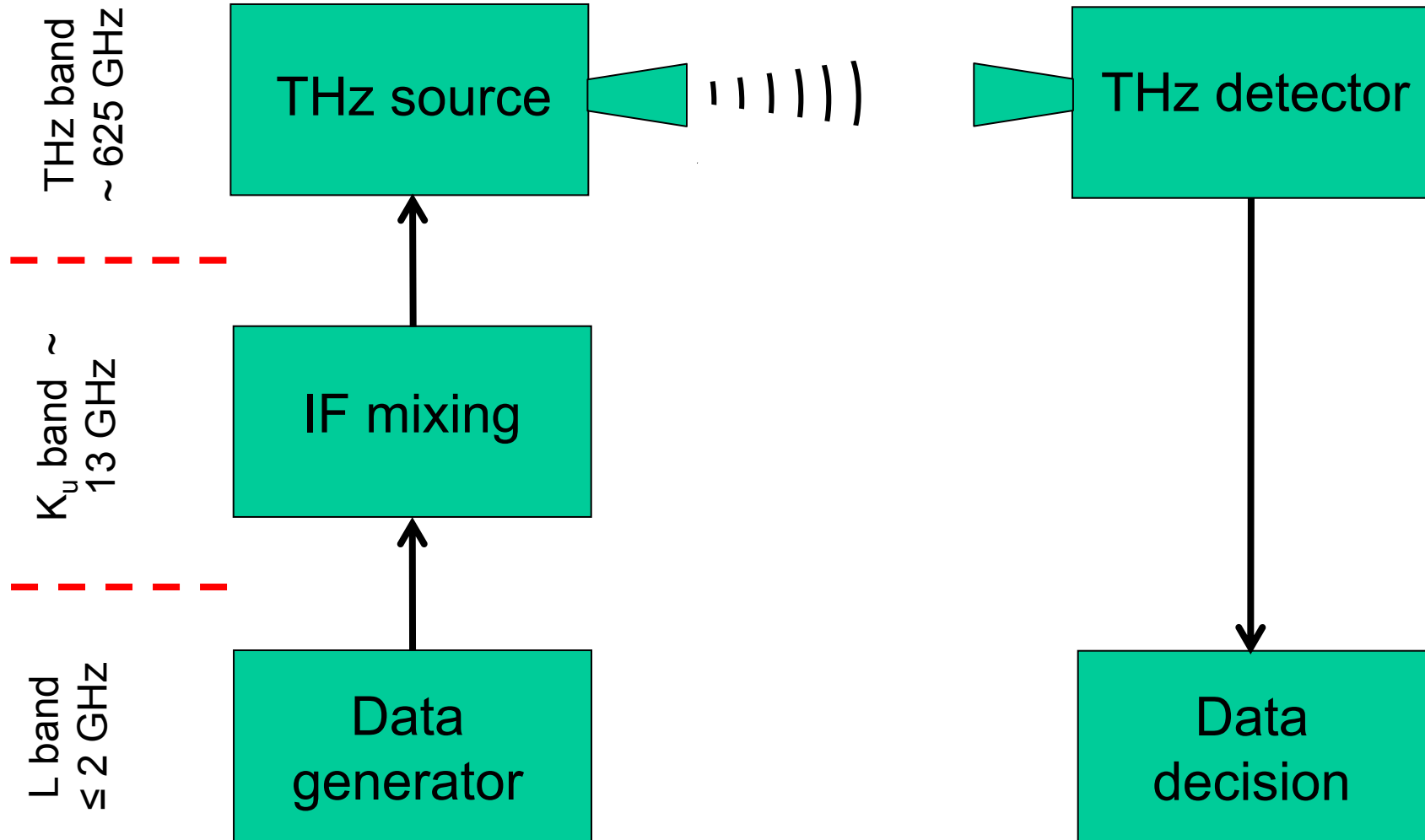

Generating narrow bandwidth 2.5 Gb/s baseband signal using Duobinary coding

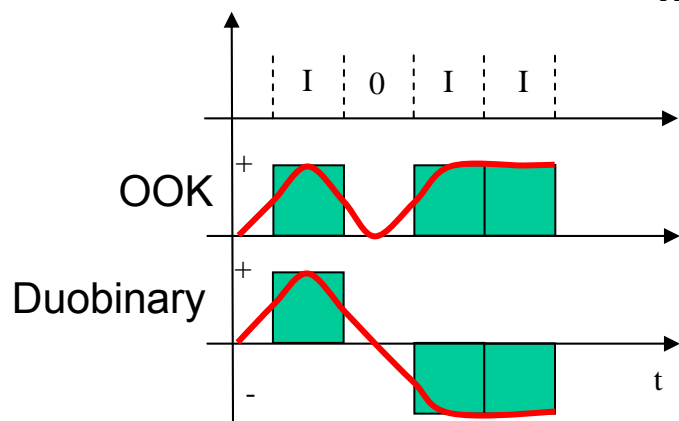
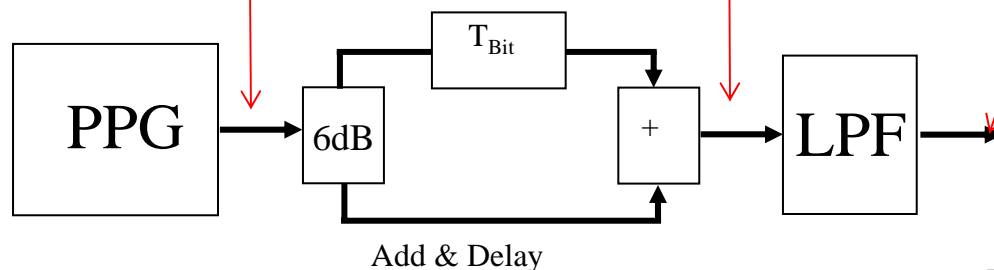
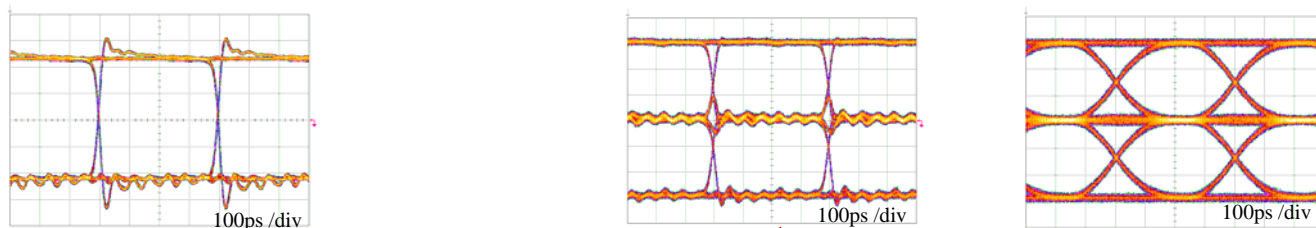

Phase coding for bandwidth reduction

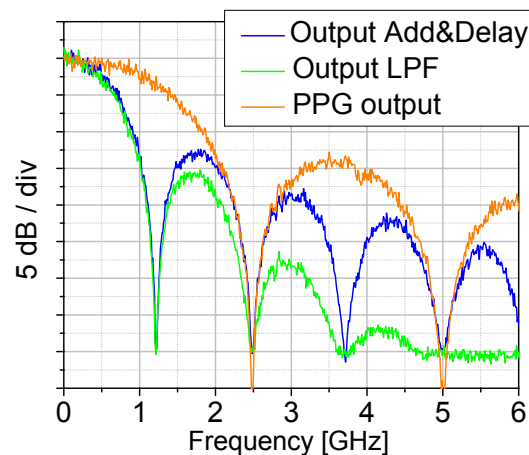

Spectra of baseband signals

Up-converting baseband signal into K_u band

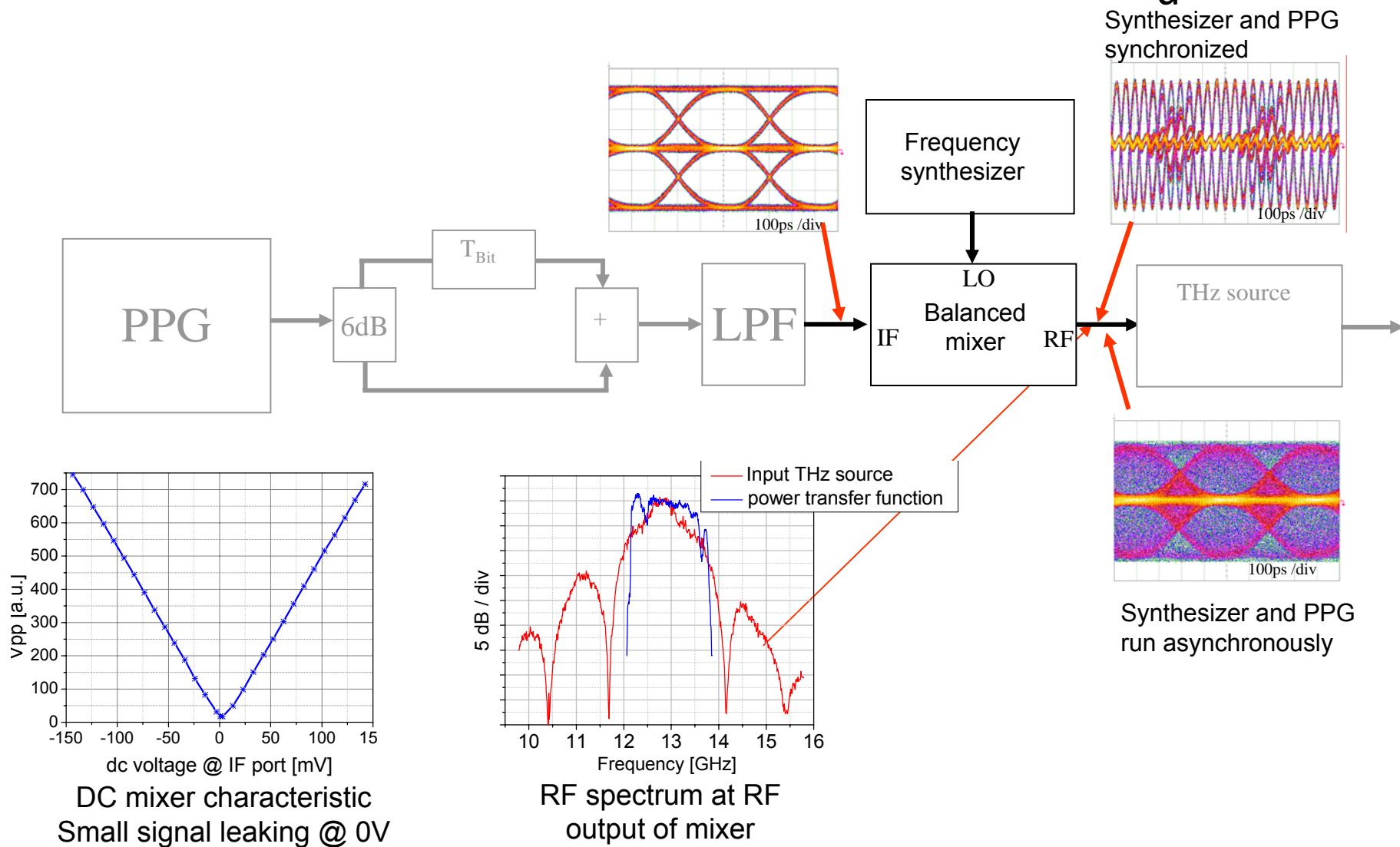

Frequency multiplier chain based 1 mW THz source

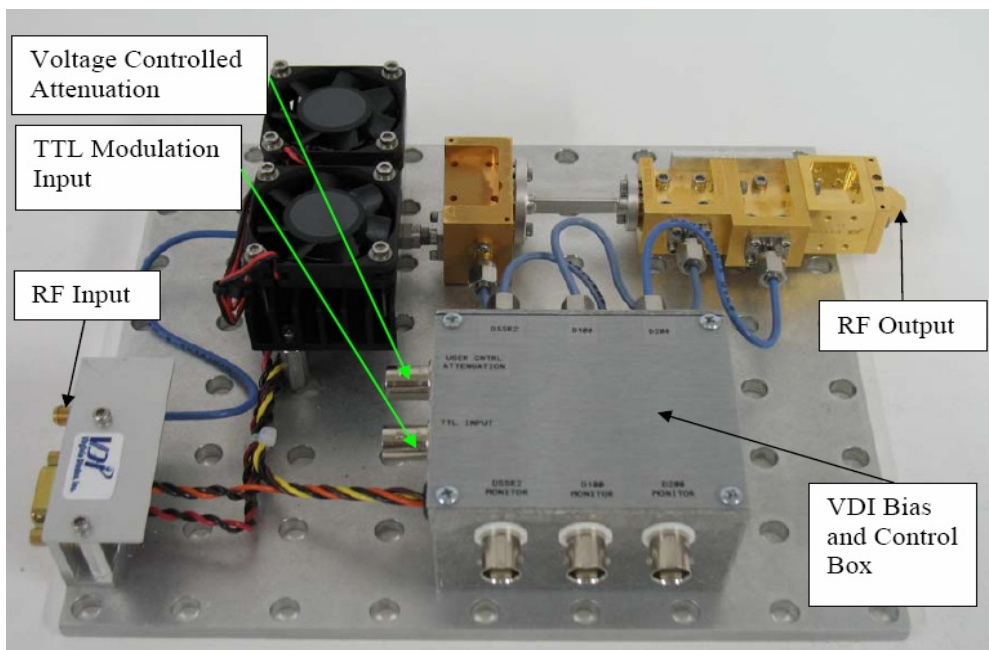
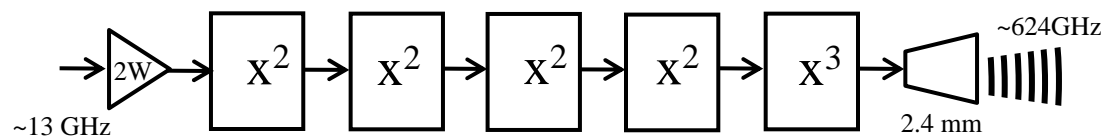

THz source from Virginia Diodes, Inc. Four doublers and one tripler up-convert a 13 GHz input tone to a 624 GHz output beam.

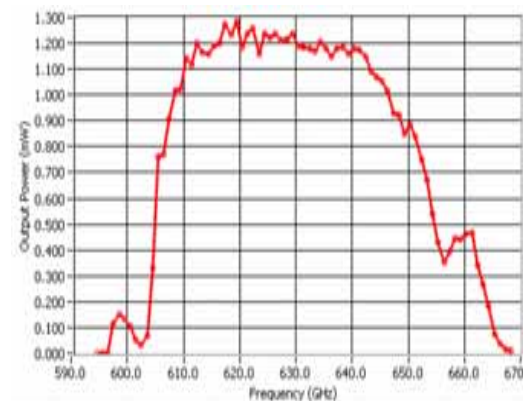

50 GHz source tuning range.

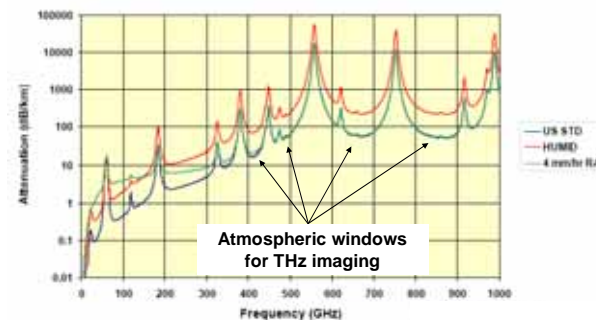

Simulated atmospheric attenuation.

Zero-biased Schottky diode based 2.5 Gb/s receiver

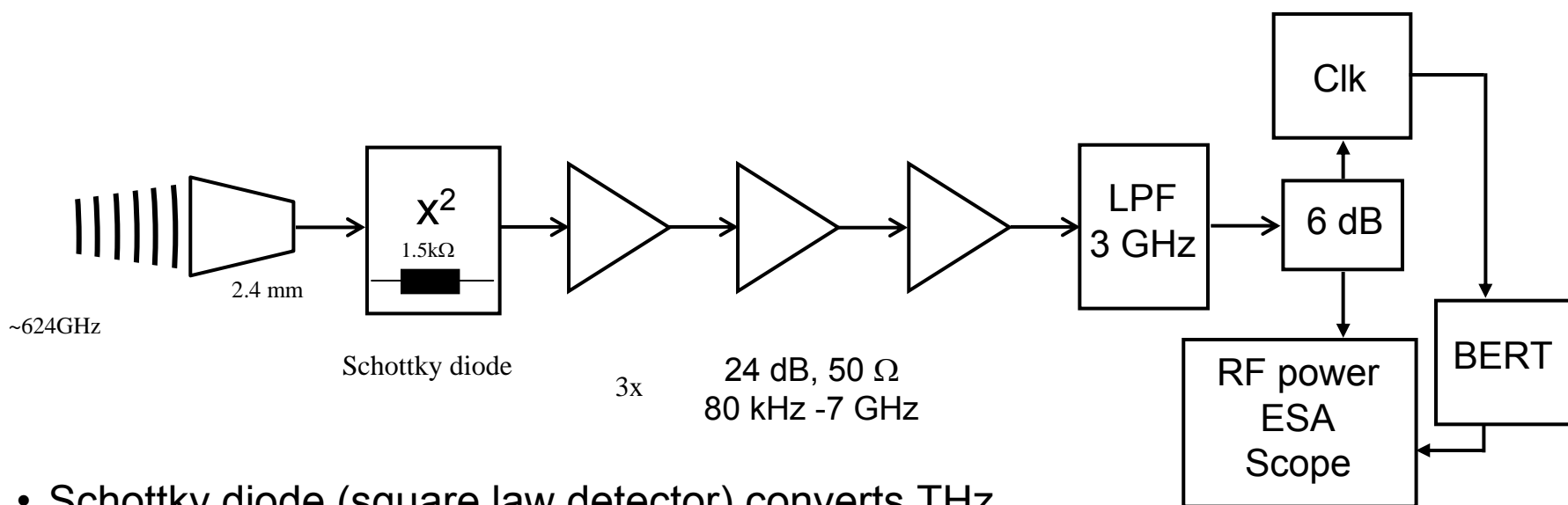

- Schottky diode (square law detector) converts THz signal into baseband.
- Un-modulated THz beam generates about 70 mW output voltage.
- ~ -30 dB voltage coupling loss into 50 Ω amplifiers (video impedance of Schottky diode ~1.5 kΩ)
- Large receiver sensitivity improvement expected after impedance matching using amplifier with high input impedance.

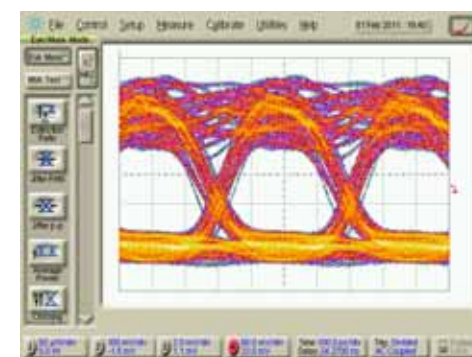

Received eye diagram at high SNR and short PRBS

System performance by BER vs. detected RF power

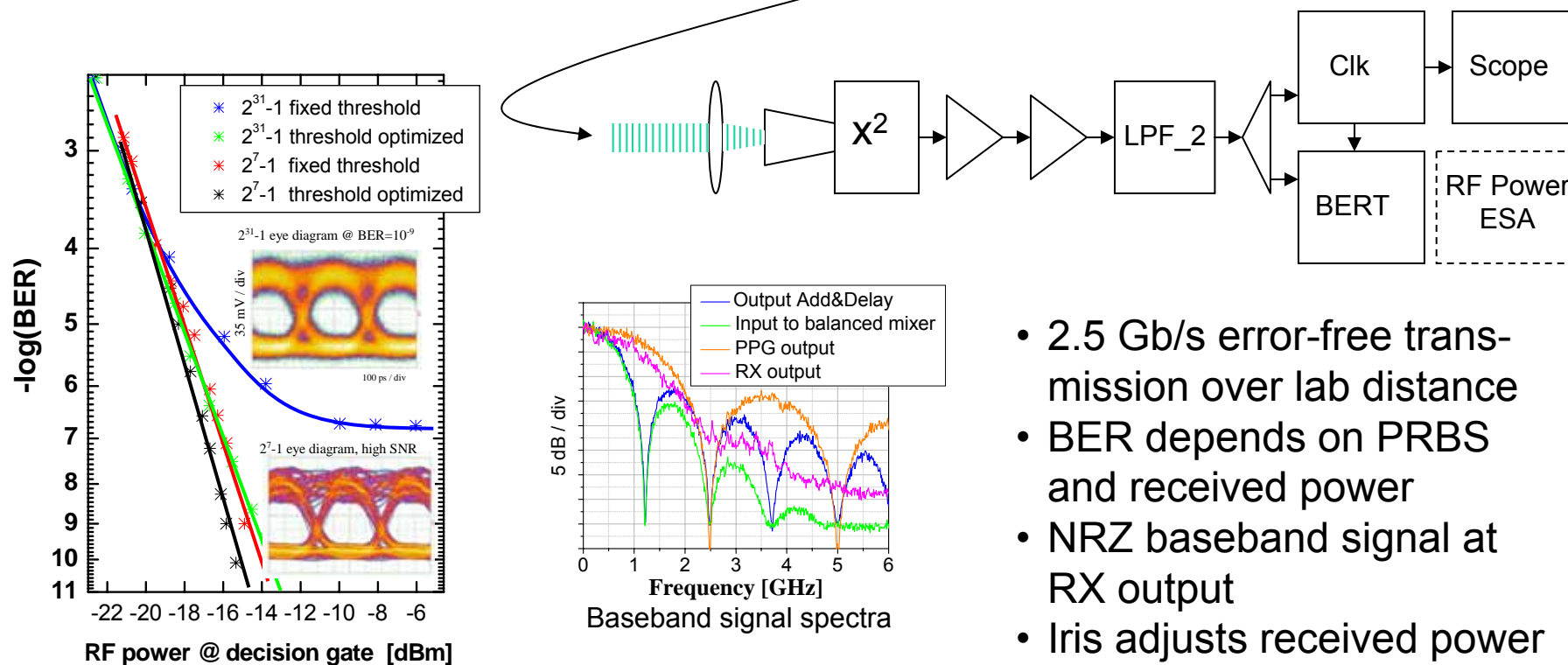
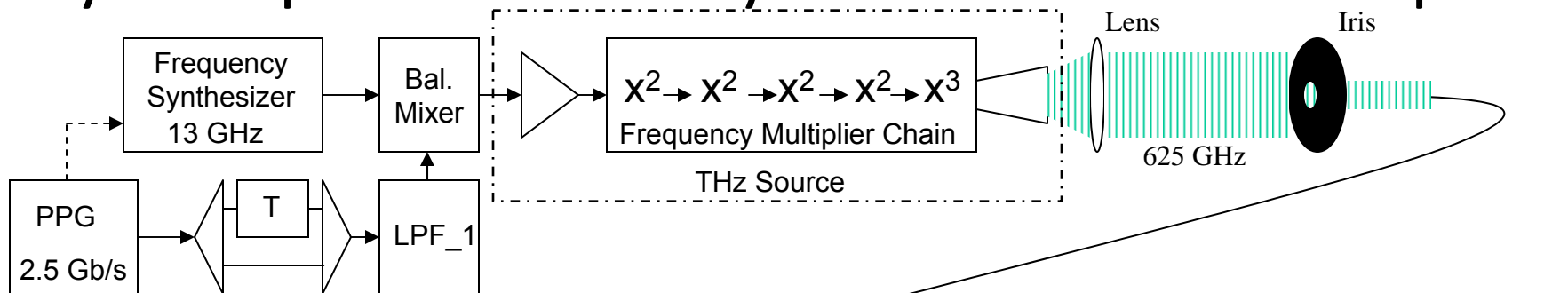

- 2.5 Gb/s error-free transmission over lab distance
- BER depends on PRBS and received power
- NRZ baseband signal at RX output
- Iris adjusts received power

2.5 Gb/s IR Communication link

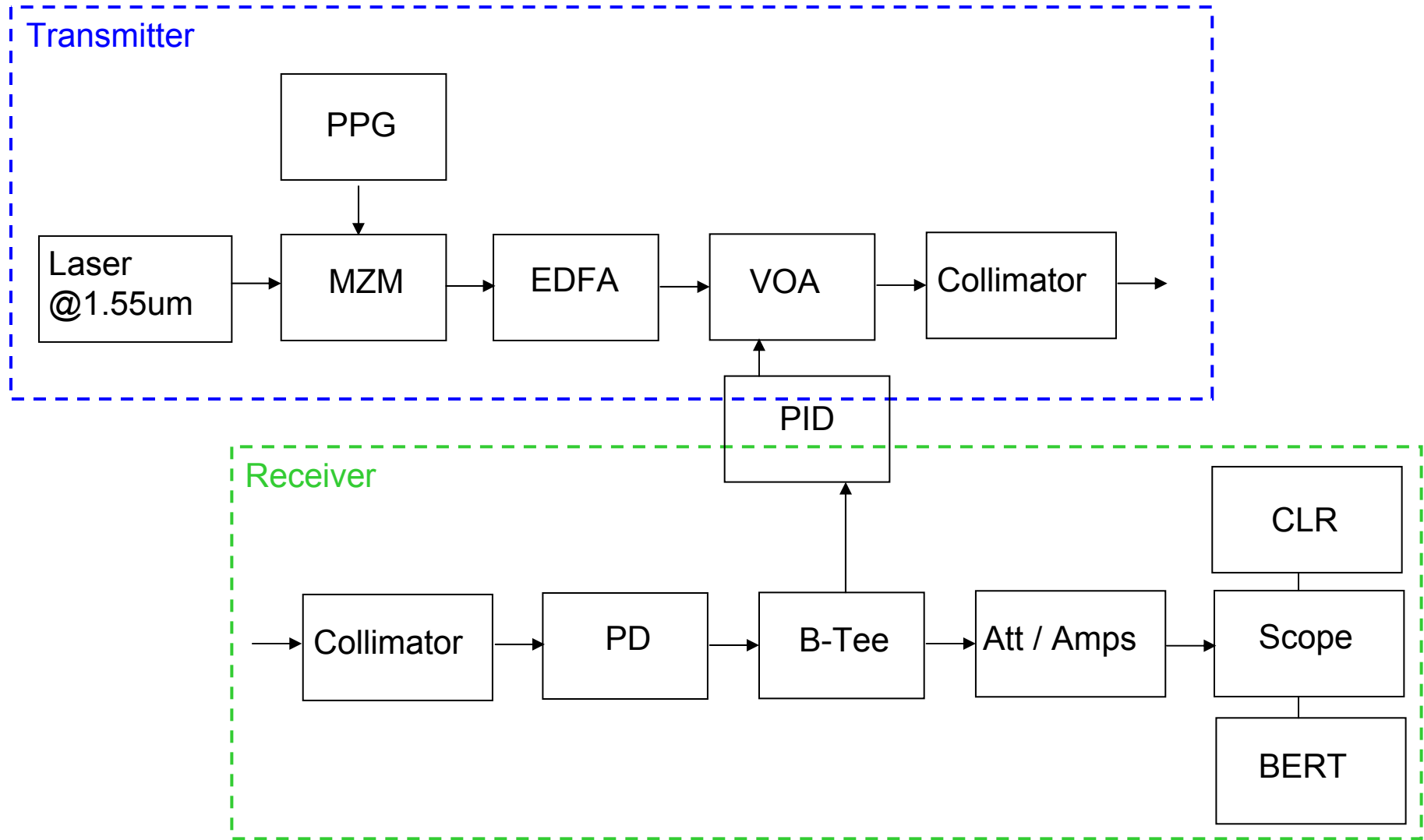

Comparing weather impact on 2.5 Gb/s THz & IR links

Superimposed signals pass same local refraction index variations

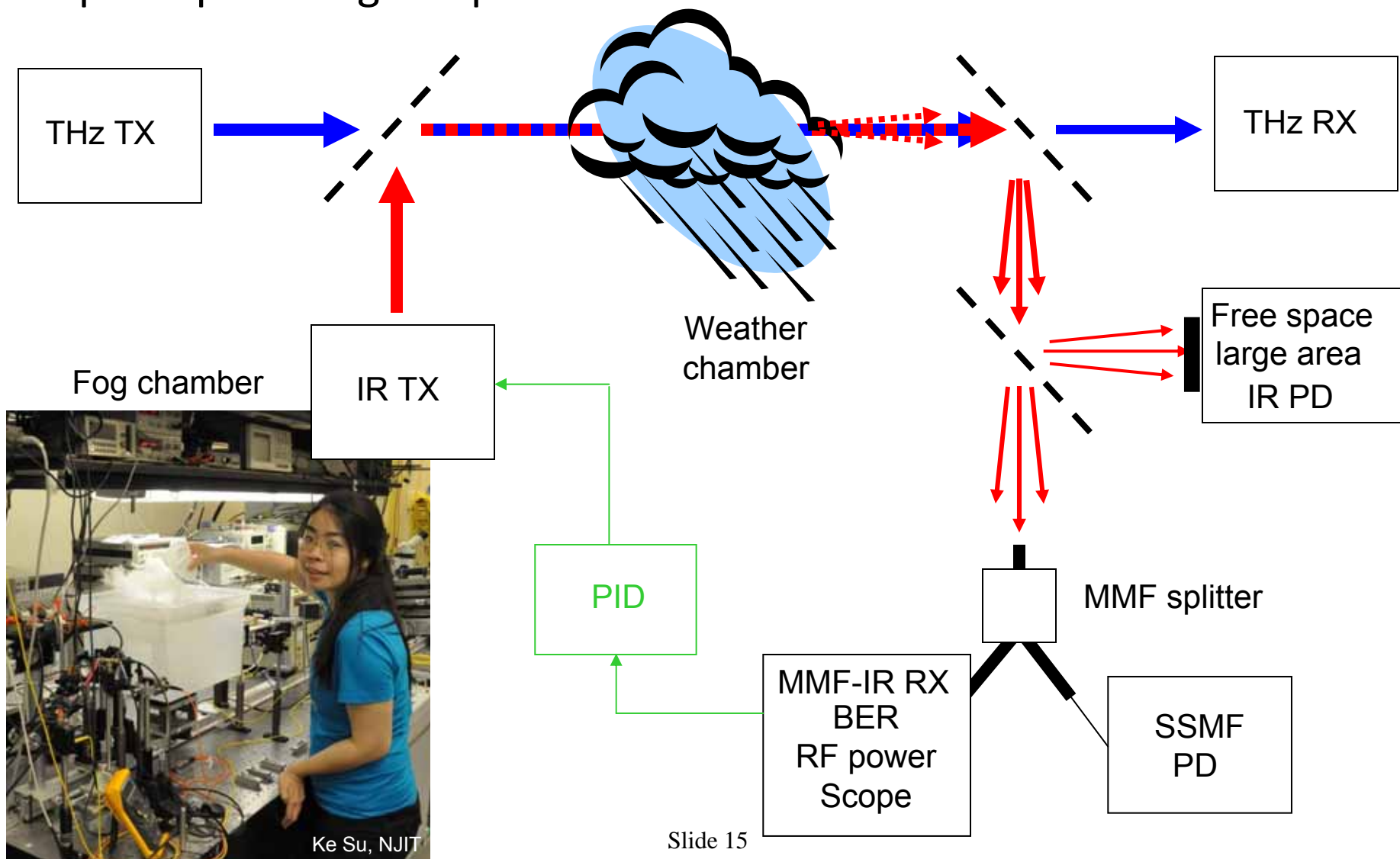

Ke Su, NJIT

Natural and artificial fog appearance

Fog

Collection of suspended water droplet or ice crystals near the earth's surface reducing horizontal visibility < 1km.



Atmospheric Visibility

defined as a distance where collimated light at 550 nm wavelength is attenuated to 5% or (2%) of original power.

<i>Types of Fog</i>	<i>Drop Size</i>	<i>Water Content</i>	<i>Formation</i>
<i>Advection fog</i>	<i>20µm</i>	<i>>0.20g/m3</i>	<i>Coastal fog</i>
<i>Radiation fog</i>	<i>4µm</i>	<i>0.01-01 g/m3</i>	<i>Inland</i>

Artificial fog

generated by dripping liquid Nitrogen into a cup filled with hot water (~80 °C).
Measured average particle diameter ~8µm.

Particle size / wavelength ratio determines dominant type of scattering

Scattering	Size parameter	Description
Rayleigh Scattering	$a \ll 1$	Particle size is much smaller than the wavelength
Mie Scattering	(0.1 ~50) $a \approx 1$	Particle size is comparable in size to the wavelength
Nonselective scattering (Geometric Scattering)	$a \gg 1$	Particle size is much larger than the wavelength

$$a = \frac{2\pi r}{\lambda}$$

r = radius of the particle
 λ = wavelength of radiation

Scattering at 625 GHz and 1.5 μm (IR) with fog particle sizes (1-20 μm)

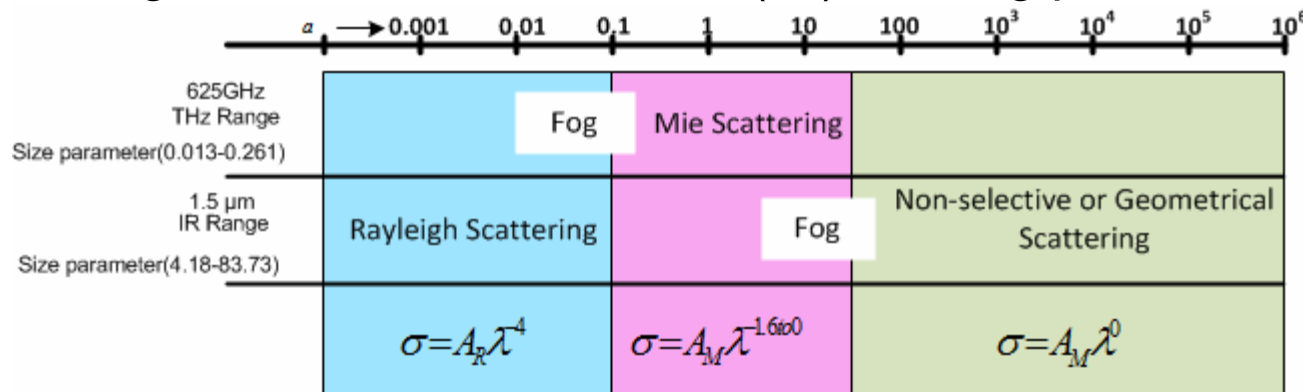

Attenuation and BERs for THz & IR links

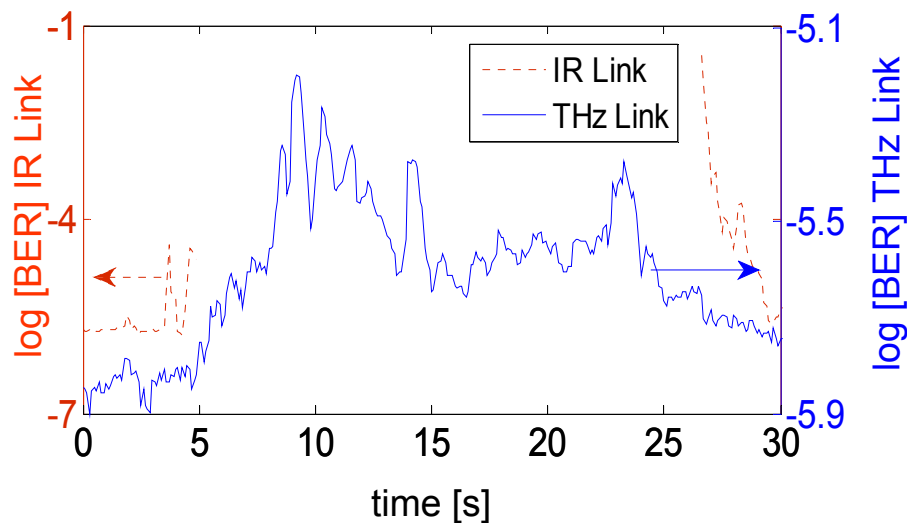
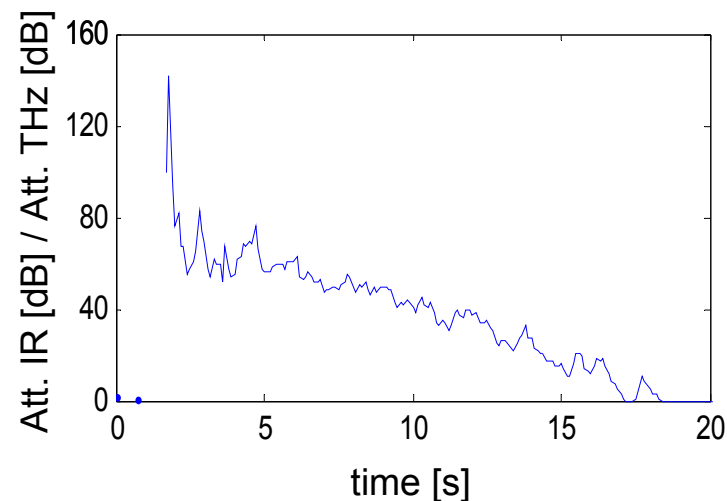
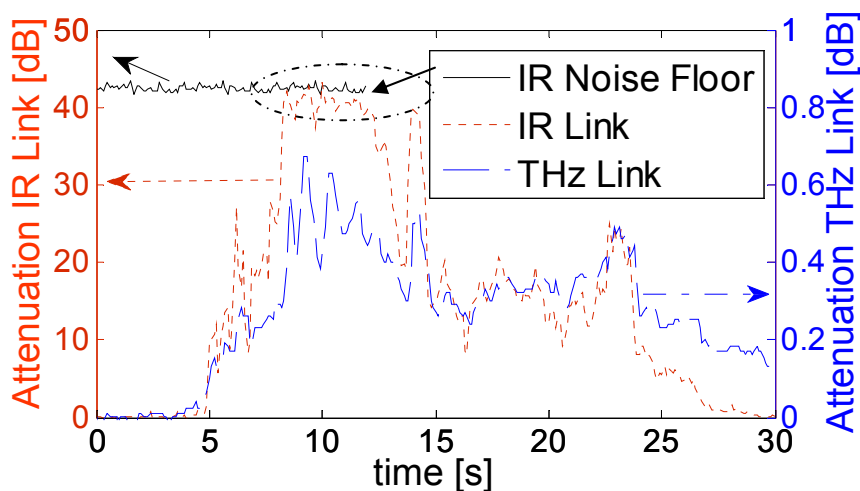

- Fog attenuates IR much stronger than THz.
- Attenuation is not proportional to fog density.
- Fog is likely converted into humidity impacting THz link.

Kim model* estimates visibility in fog chamber

Attenuation coefficient approximated by:

$$\gamma(\lambda) = \frac{3.912}{V} \left(\frac{\lambda}{550}\right)^{-q}$$

V: visibilty

q: fct of particle size distribution

$$q = \begin{cases} 1.6 & V > 50km \\ 1.3 & 6km < V < 50km \\ 0 & V < 500m \\ V - 0.5 & 500m < V < 1km \\ 0.16V + 0.34 & 1km < V < 6km \end{cases}$$

relation between q and V.

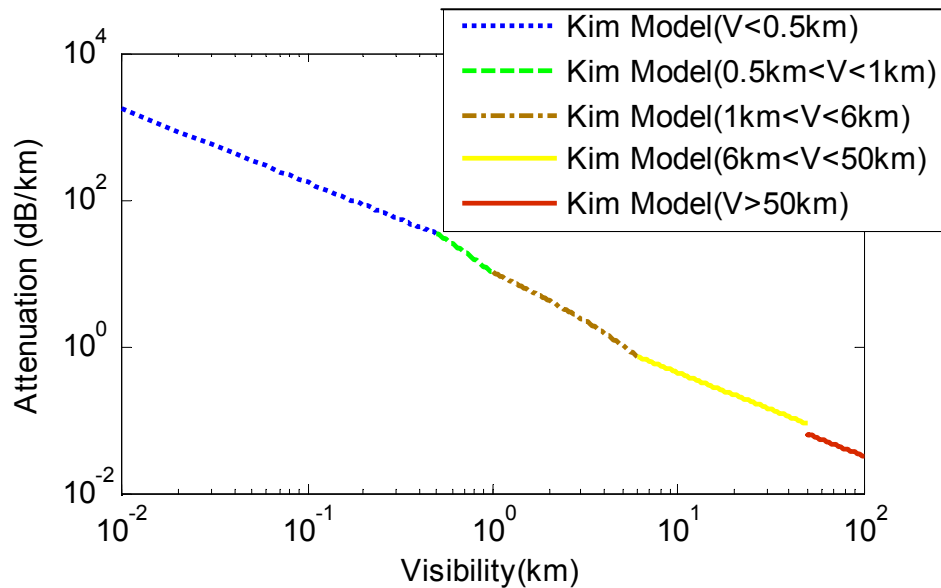

$$a_{spec} (dB / km) = \frac{10}{\ln(10)} \gamma(\lambda)$$

*Kim, I., B. McArthur, and E. Korevaar. "Comparison of laser beam propagation at 785 and 1550 nm in fog and haze for opt. wireless communications." in Proc. SPIE 2001.

Fog density specified by visibility

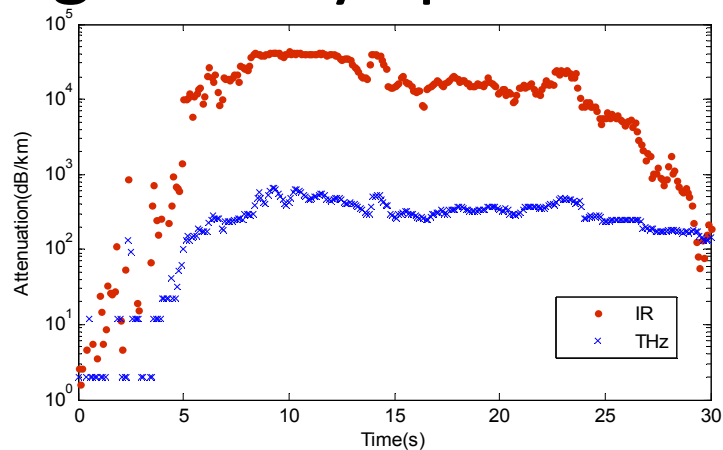

Specific attenuation of THz link and IR link over time

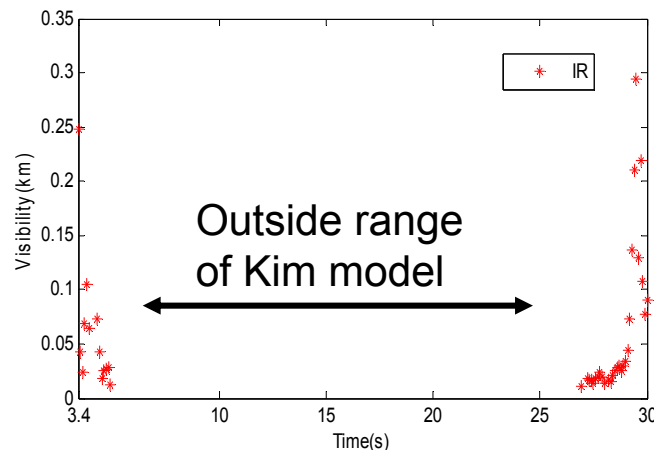

Visibility over time simulated by Kim model

Visibility (m)	Water Density (g/m ³)	Experimental Specific Attenuation (dB/km)	Theoretical Specific Attenuation (dB/km)
300	0.05	2	1.40
50	0.5	14	12
10	1	28	22

Comparison of THz experimental and theoretical specific attenuation at different visibilities using Double-Debye model*

* H.J. Liebe et al., "A model for the complex permittivity of water at frequencies below 1THz," Int. J. of Infrared and Millimeter Waves, Vol.12, No. 7, 1991.

Scintillation effects in Fog chamber impact IR link

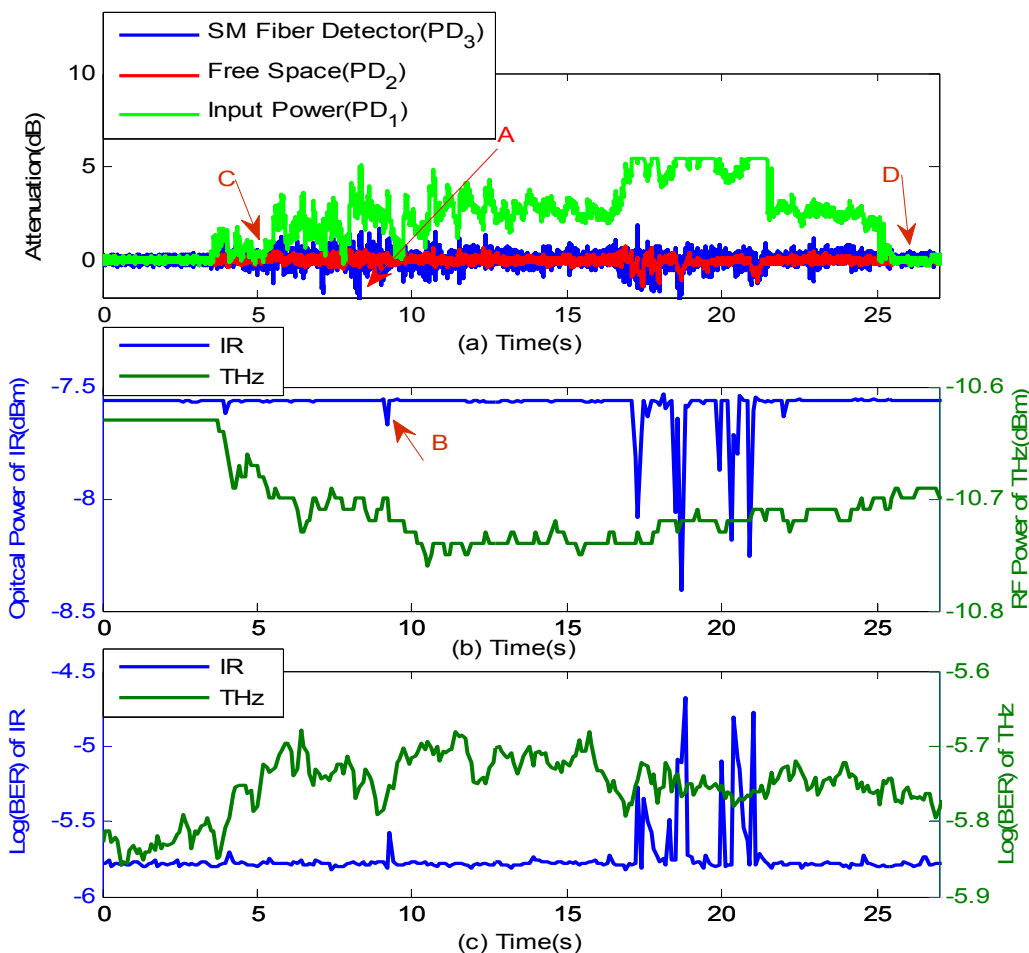

Scintillation Effects

Pointer A:
Fluctuations PD₁ >> PD₂ & RX power const.

Humidity impact

Pointers C and D:
IR attenuation ~ 0 & attenuation THz ~ 0.1dB
-> Conversion of fog into humidity

Unstable operation of PID loop

Pointer B:
small kinks indicate fast changing attenuation;
insufficient controller bandwidth

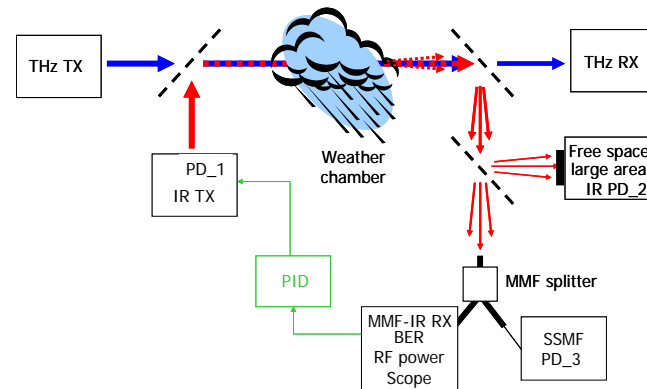

Conclusions

- THz link outperforms IR system under experimental fog conditions.
- Demonstrated error-free 2.5 Gb/s (SDH 16) transmission over lab distance at 625 GHz using a 1mW THz source.
- Duodinary modulation yields compact baseband spectrum thin enough to fit through the resonance of THz source.
- Developed setup that allows studying THz and IR links propagating at the same time through the same fog.
- Fog degrades THz link much less than IR link – error free operation possible when IR link has collapsed.
- Scintillation effects in IR link observed.