

Project: IEEE P802.15 Working Group for Wireless Personal Area Networks (WPANs)

Submission Title: [A MAC Proposal for LECIM]

Date Submitted: [September, 2011]

Source: [Kyungsup Kwak, Jaedoo Huh*, M. Al Ameen, Niamat Ullah, M. Sanaullah Chowdhury]

Company: [Inha University, ETRI*]

Address [428 Hi-Tech, Inha University, 253 Yonghyun-dong, Nam-gu, Incheon, 402-751, Republic of Korea], [ETRI, 161 Gajeong-dong, Yuseong-gu, Daejeon, 305-700, Republic of Korea]*

Voice: [+82-32-860-7416], FAX: [+82-32-876-7349],

E-Mail: [kskwak@inha.ac.kr (other contributors are listed in “Contributors” slides)]

Re: [IEEE802.15.4k LECIM final call for proposal]

Abstract: [A MAC Proposal addressing the functional requirements of the low energy critical infrastructure monitoring applications]

Purpose: [To be considered in IEEE 802.15.4k]

Notice: This document has been prepared to assist the IEEE P802.15. It is offered as a basis for discussion and is not binding on the contributing individual(s) or organization(s). The material in this document is subject to change in form and content after further study. The contributor(s) reserve(s) the right to add, amend or withdraw material contained herein.

Release: The contributor acknowledges and accepts that this contribution becomes the property of IEEE and may be made publicly available by P802.15.

Contributors

Name	E-mail	Affiliation
Kyungsup Kwak	kskwak@inha.ac.kr	Inha University
Jaedoo Huh	jdjuh@etri.re.kr	ETRI, Korea
M. Al Ameen	m.ameen@hotmail.com	Inha University
Niamat Ullah	niamatnaz@gmail.com	Inha University
M. Sanaullah Chowdhury	sana1691@gmail.com	Inha University

Outline

- Introduction
- MAC Protocol Description
- MAC Communication Process
- MAC Frame Structure
- Performance Evaluation
- Conclusion
- Appendix

Introduction

- The Low Energy Critical Infrastructure Monitoring (LECIM) Task Group 4k (TG4k) is formed as an amendment to IEEE 802.15.4
- Many applications fall under the category of critical infrastructure
 - e.g. water leak detection, sewer, bridge/structural integrity, fault circuit indicators, soil, oil & gas pipeline, cargo container, traffic, railroad condition, gas/hazardous material detection, perimeter security, border surveillance, medical alert for at-risk populations, and so on
- The purpose of TG4k is to facilitate communications for the critical infrastructure monitoring devices
- It addresses the needs of minimal network infrastructure, and enables the collection of scheduled and event data from a large number of non-mains powered endpoints that are widely dispersed, or are in challenging propagation environments
- It will support low energy operation necessary for multi-year battery life with minimal network maintenance

LECIM Requirements

- Primarily outdoor environment
- Application data rate up to 40 Kbps
- Thousands of endpoints per mains powered infrastructure
- Asymmetric application data flow
- Endpoints must be able to conserve energy
- Reliable operation in dramatically changing environments
- Long deployment life w/o human contact
- Small, infrequent messages
- Tolerant to data latency
- Addressing should support thousands of connected endpoints
- Network devices
 - Coordinator (Collector) typically mains powered
 - Endpoints are typically battery powered
- No mobility for endpoints but limited portability for coordinator

Need for a New MAC

- The size of the network is very large
- Energy consumption and lifetime are major design requirements with delay tolerance
- The present 802.15.4/4e MACs needs modification to support such a large network with very lossy channel
- 802.15.4e has a concept of slot ownership. This can degrade the performance of the 4k network due to very large number of nodes
- CSMA/CA is not feasible due to wide coverage and large number of endpoints.
 - hidden nodes, near-far problem, severe path loss, deep fades, etc.
- A less complex MAC be used in light of energy consumption

Network Topology

- The topology is star to support one to multipoint communication
- The network has one coordinator supporting many endpoints

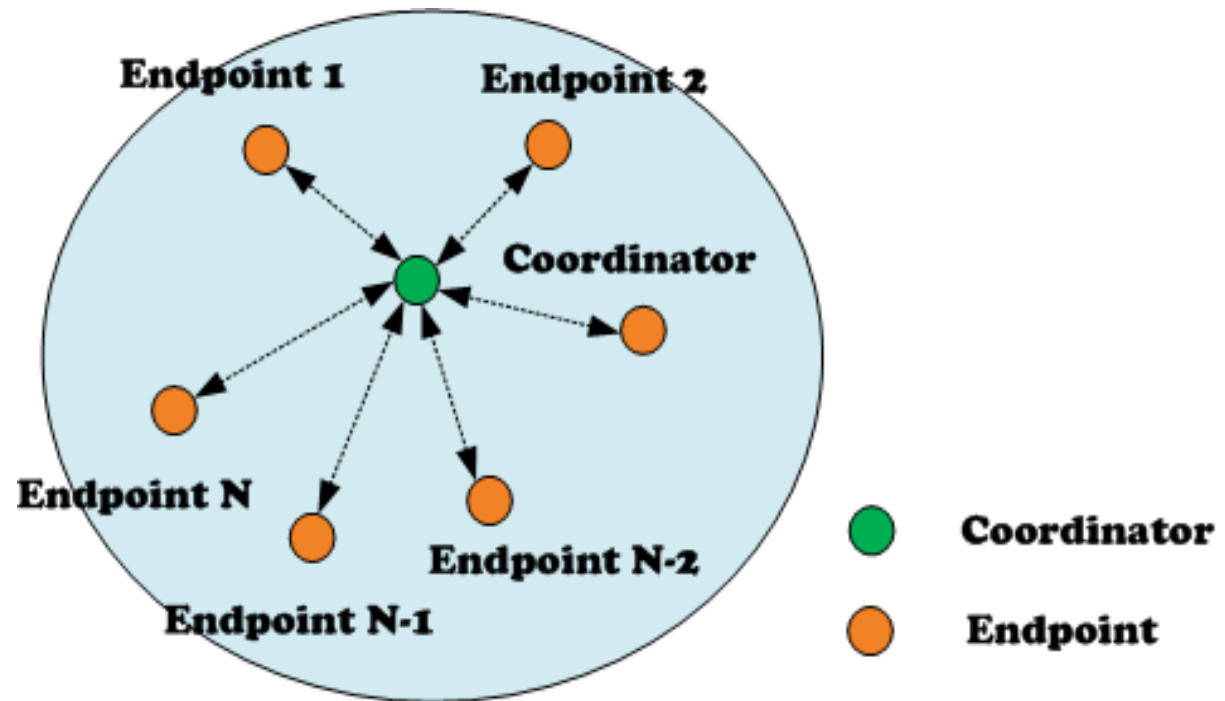

Proposed MAC Modes

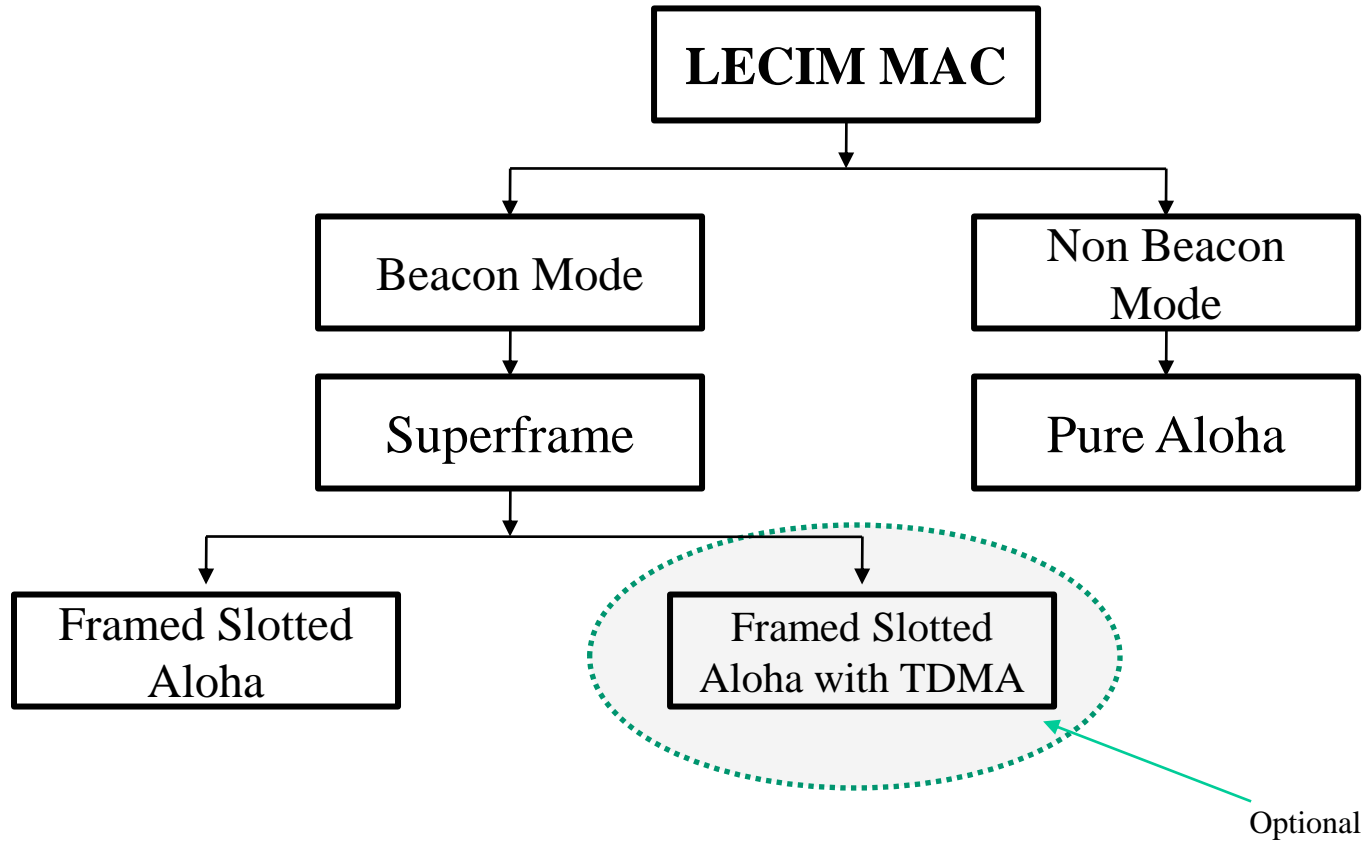

Superframe Design (1)

- The superframe contains time slots
 - The number of slots can vary and is a design parameter
- The superframe has the following parts
 - Beacon
 - EAP
 - NAP

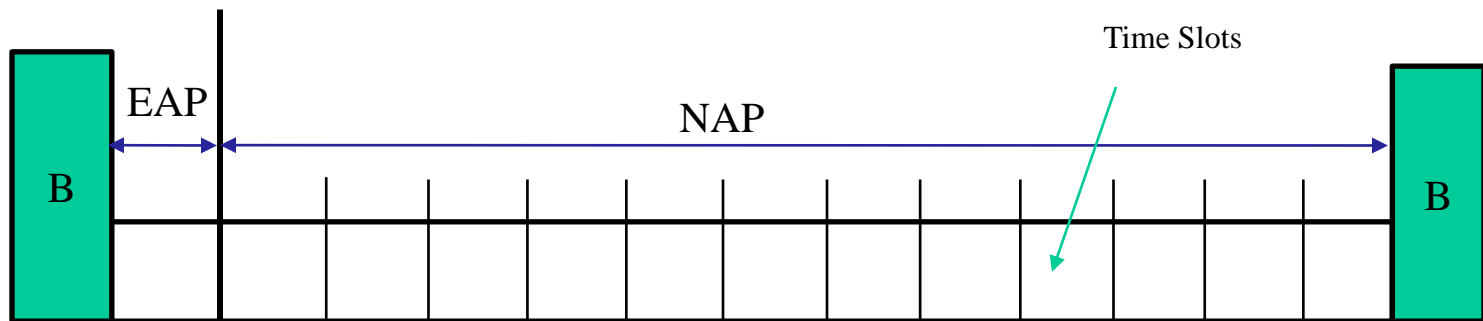

B: Beacon Period, **EAP:** Emergency Access Period, **NAP:** Normal Access Period

Superframe Design (2)

- Beacon
 - Beacon is used for synchronization, resource allocation and network management
 - The first slot in the superframe is reserved for the beacon
- EAP is Emergency Access Period
 - It is used for emergency traffic only
- NAP is Normal Access Period
 - It is used for normal communication in the network
 - The number of slots in NAP can be optimized as per the network size

Superframe Design (3)

- Optionally, we can use a superframe with EAP and NAP with GAP periods
- GAP contains GTS slots in TDMA base
 - Examples: Factory, small size grid, power plants etc.

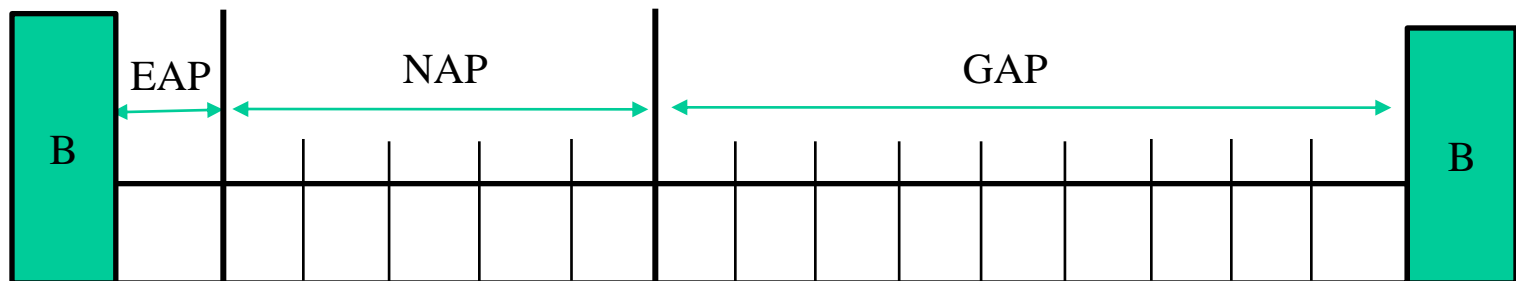

GAP: Guaranteed Access Period (contains Guaranteed Time Slots (GTS))

Slot Design

- A superframe is divided into slots
- All the slots are of equal length
- Duration of slots are configurable as per application requirements
 - Probable slot duration and size on supported data rates and possible data packets are investigated
- A communication starts in the beginning of a slot

**Details are presented in Appendix –A*

Superframe Design: Slot and Packet Size

- The proposed frame sizes with possible number of slots are shown
- We investigated the slot duration and packet sizes: max. data rate =40kbps

Superframe size	512ms		256ms	
	Slot Duration (ms)	Packet Size (Bytes)	Slot Duration (ms)	Packet Size (Bytes)
16	32	160	16	80
32	16	80	8	40
64	8	40	4	20
128	4	20	2	10
256	2	10	1	5

11 Bytes

2 Bytes

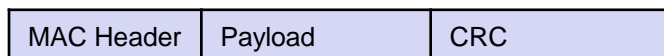

MaxPacket size=13Bytes + Payload



Non-usable

**Details are presented in Appendix –B*

MAC Working

- In the beacon mode, the coordinator sends beacon on regular intervals
- An endpoint wakes up on its own schedule (when the event of interest occurs), and listens for the beacon
- When it gets the beacon, it synchronizes to the superframe
- It sends the packet using the framed slotted Aloha
 - The endpoint **chooses a slot uniformly** in the NAP
- After successful transmission the endpoint goes to sleep
- If the packet collides, it tries again in the next superframe
- In the non-beacon mode, the endpoint uses pure Aloha scheme

MAC Timing Diagram

- Beacon enabled mode using framed slotted Aloha protocol is shown

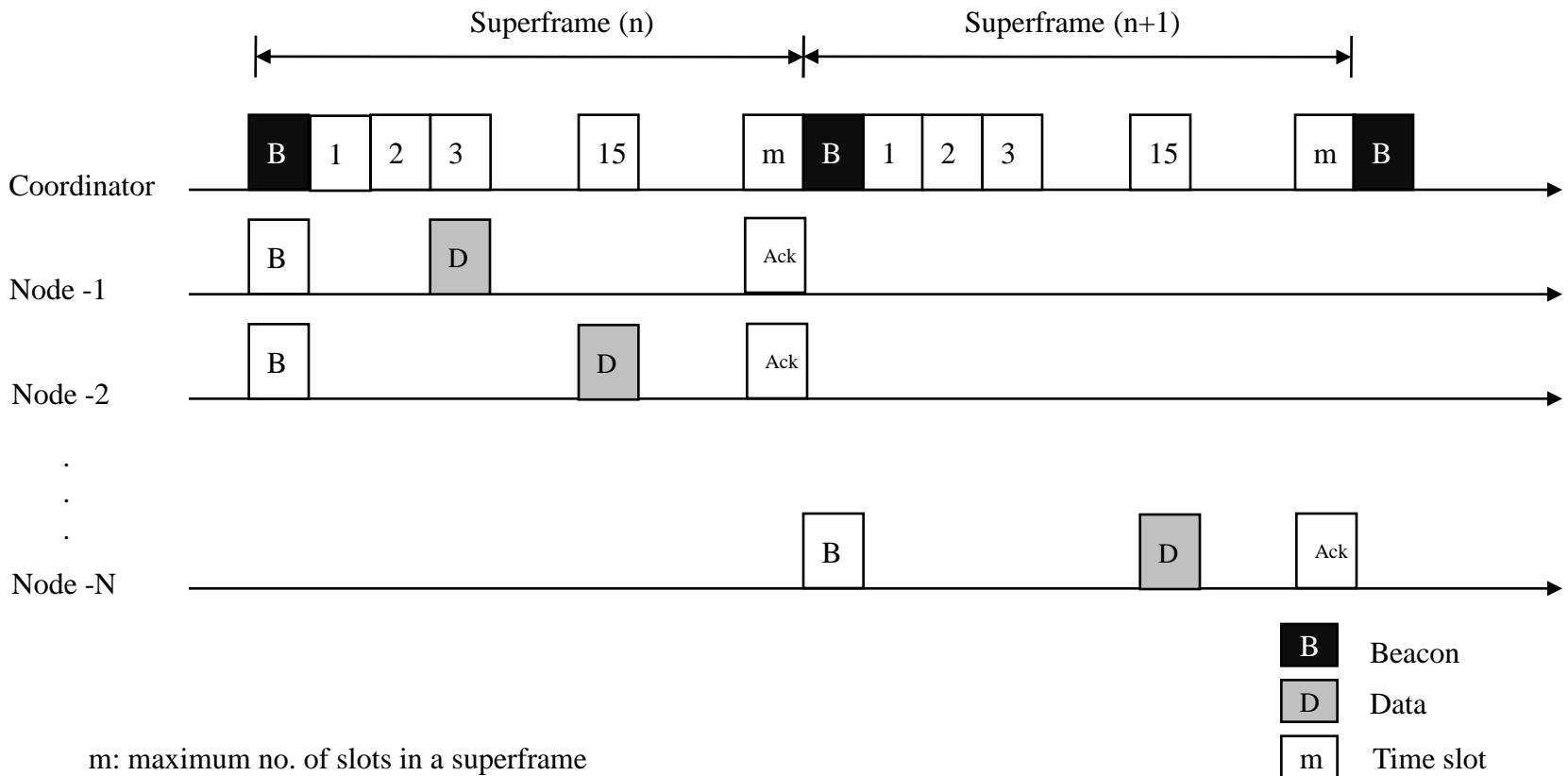

Flow Chart

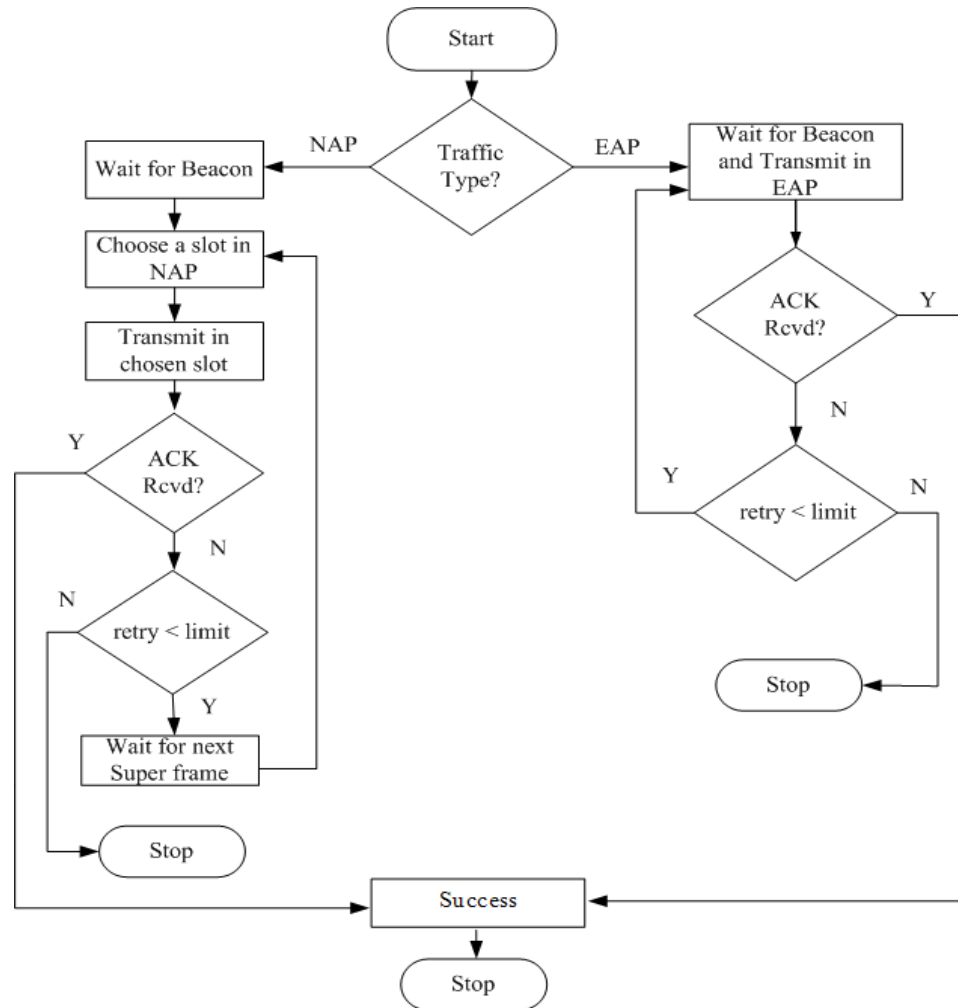

MAC Communication Process (1)

- Uplink communication
 - Uplink is for data transfer from endpoints to the coordinator

Beacon Mode

Framed Slotted Aloha is used for communication

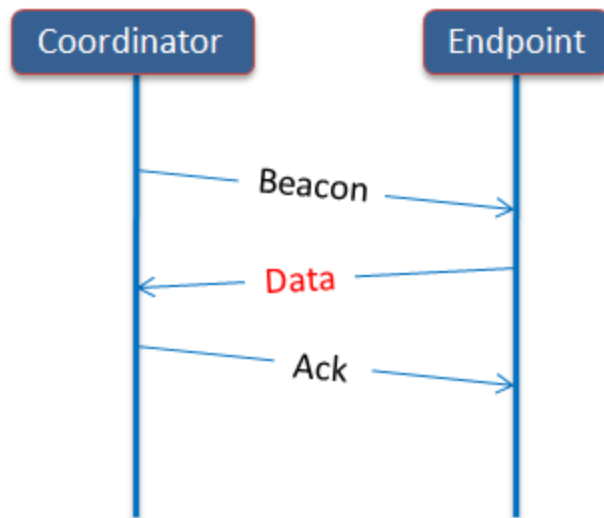

Non-Beacon Mode

Pure Aloha is used for communication

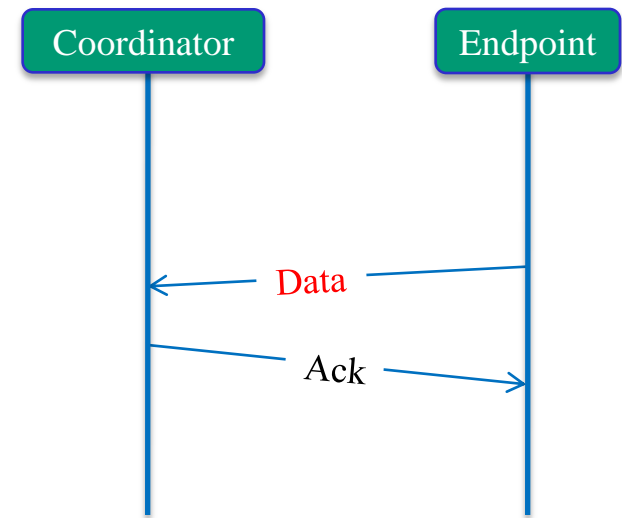

MAC Communication Process (2)

- Downlink communication
 - Downlink is for data transfer from coordinator to the endpoints

Beacon Mode

Notification through Beacon

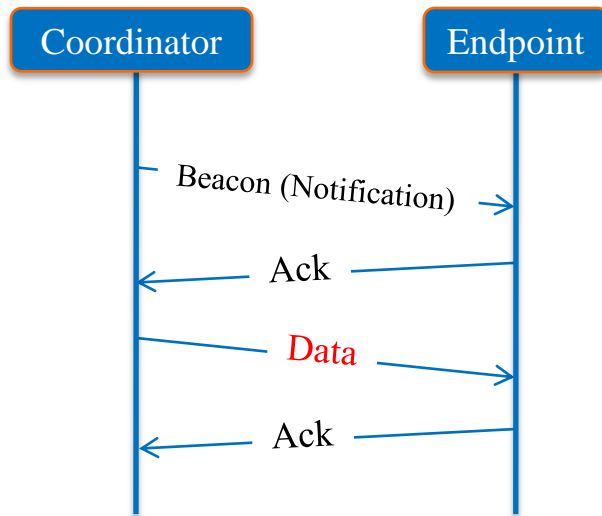

Non-Beacon Mode

Using Keep Alive/Status Message

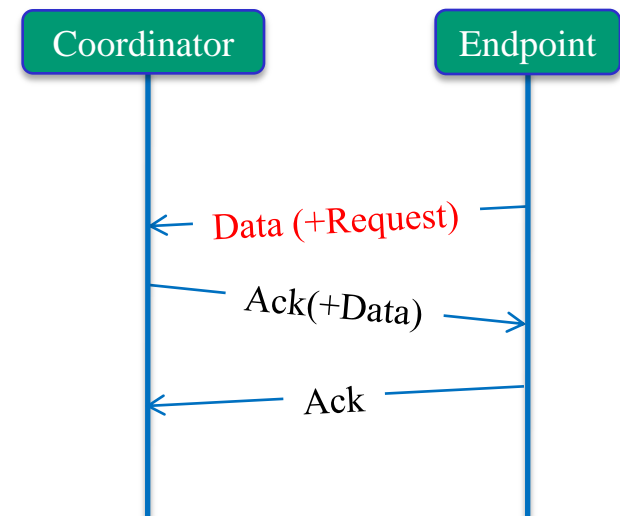

**Details are presented in Appendix -C*

Fragmentation

- LECIM supports short packet size
- Fragmentation will be necessary for large packet size if used in shorter slot duration (e.g. 160 Bytes in 8ms slot duration at 40kbps)
- Maximum fragmentation count is to be set for particular data packet
- All fragments are of the same length except the last one
- The coordinator reassembles the complete packet in correct order
- The coordinator discards any packet with missing fragments

MAC Addressing

- Provide supports for $>10,000$ nodes per network
- MAC address fields
 - Source address
 - Destination address
 - Source network ID
 - Destination network ID
- 16-bits addressing scheme is proposed for the endpoints
 - Can support up to 65,536 endpoint per network
- 8-bits addressing scheme is proposed for the network ID

Emergency Handling (1)

- Emergency event can occur to an endpoint
 - Problem occurring to the endpoint itself
 - Malfunction
 - Critical battery life situation
- Emergency handling mechanism is proposed for both beacon and non-beacon enabled modes

Emergency Handling (2)

- Emergency handling in beacon mode
 - Send emergency command using framed slotted Aloha in EAP period
- Emergency handling in non-beacon mode
 - Send emergency command using pure Aloha
- Emergency command contains specific event type information, e.g. fire, short circuit, critical battery etc.
 - An endpoint sends emergency command when remaining battery power reaches 10% of its capacity
- Optionally, a data packet can be used that contains detail information about the emergency event

Status Report Handling

- An endpoint optionally sends *status report* (keep alive packet) to the coordinator
 - It contains remaining battery capacity and status information
- Status report can be generated weekly, monthly, bi-monthly as per the application requirements
- Generating status report
 - The coordinator assigns a predefined period to every endpoint
 - The period is unique for each endpoint and is assigned when an endpoint joins the network
 - The endpoint sends status report in the NAP
 - Also the residual battery capacity can be used as parameter to generate the status report
 - E.g. after every 5% decrease in the battery capacity

MAC Frame Structure (1)

- The general MAC frame is as shown below

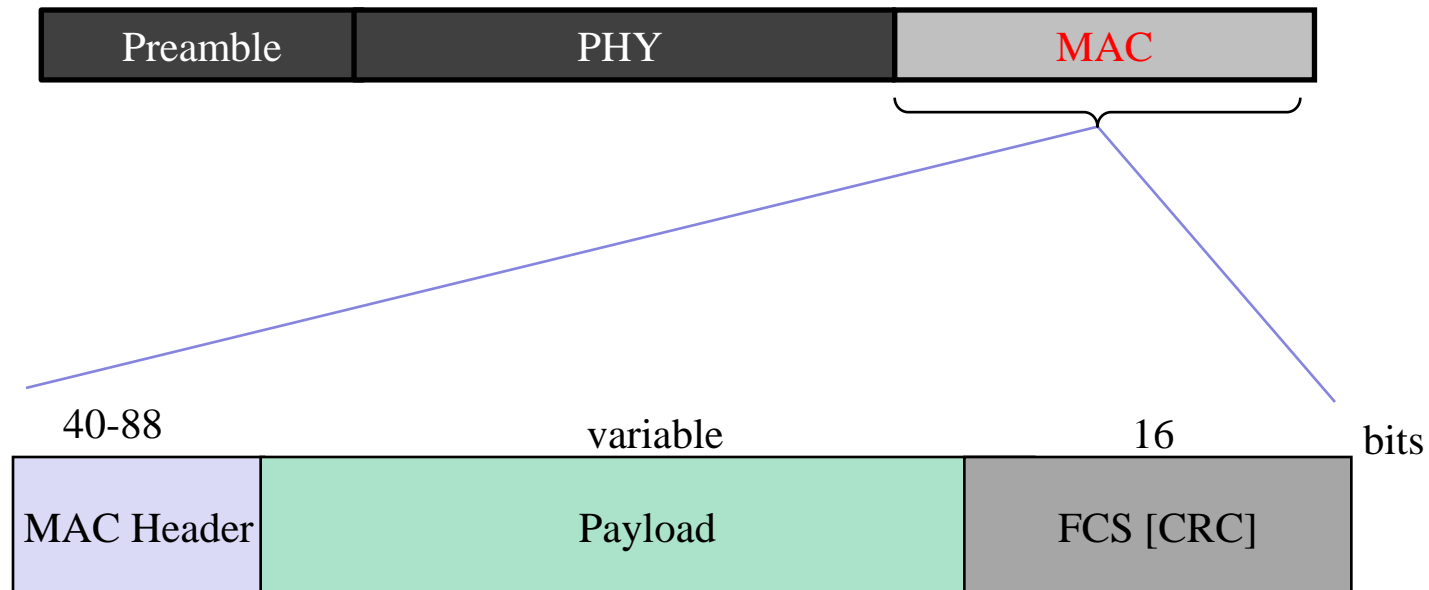

Max. MAC frame length: $11 + 2 + \text{payload}$ (octets)

MAC Frame Structure (2)

- MAC header

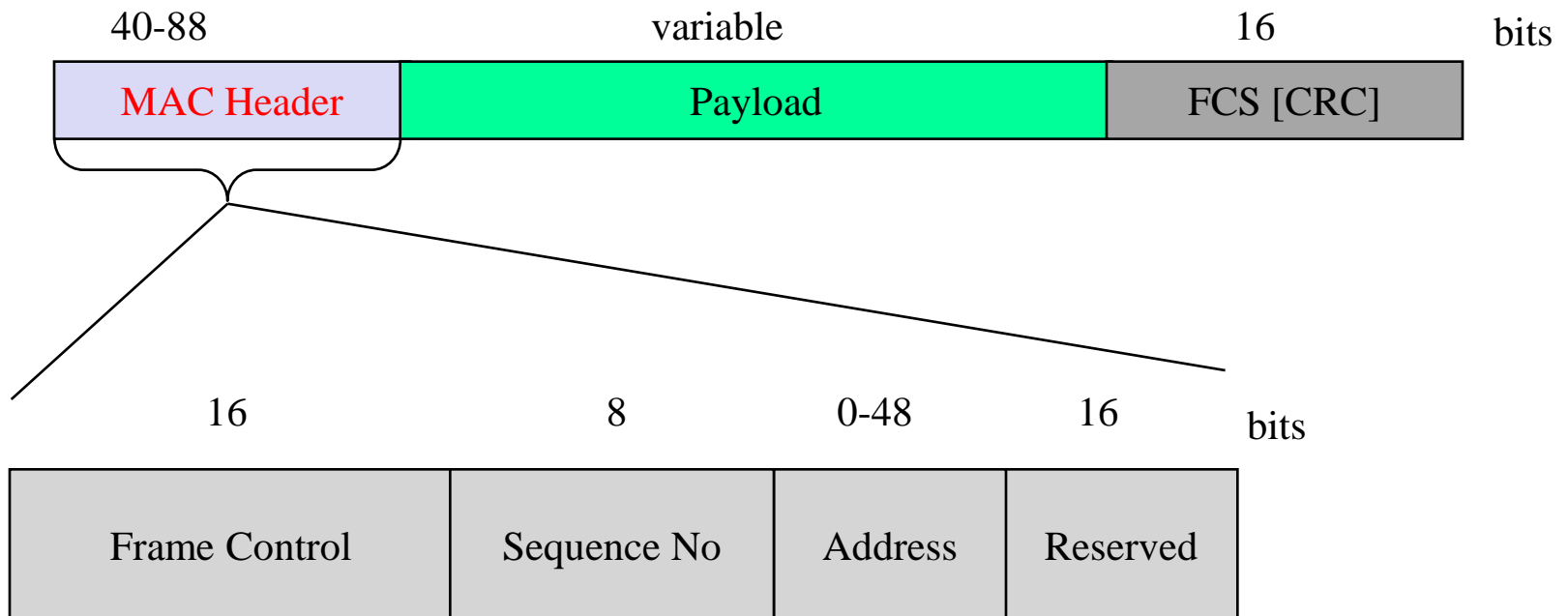

Reserved field in the Header: For fragmentation and other for future use.

MAC Frame Structure (3)

- Frame control: Type field

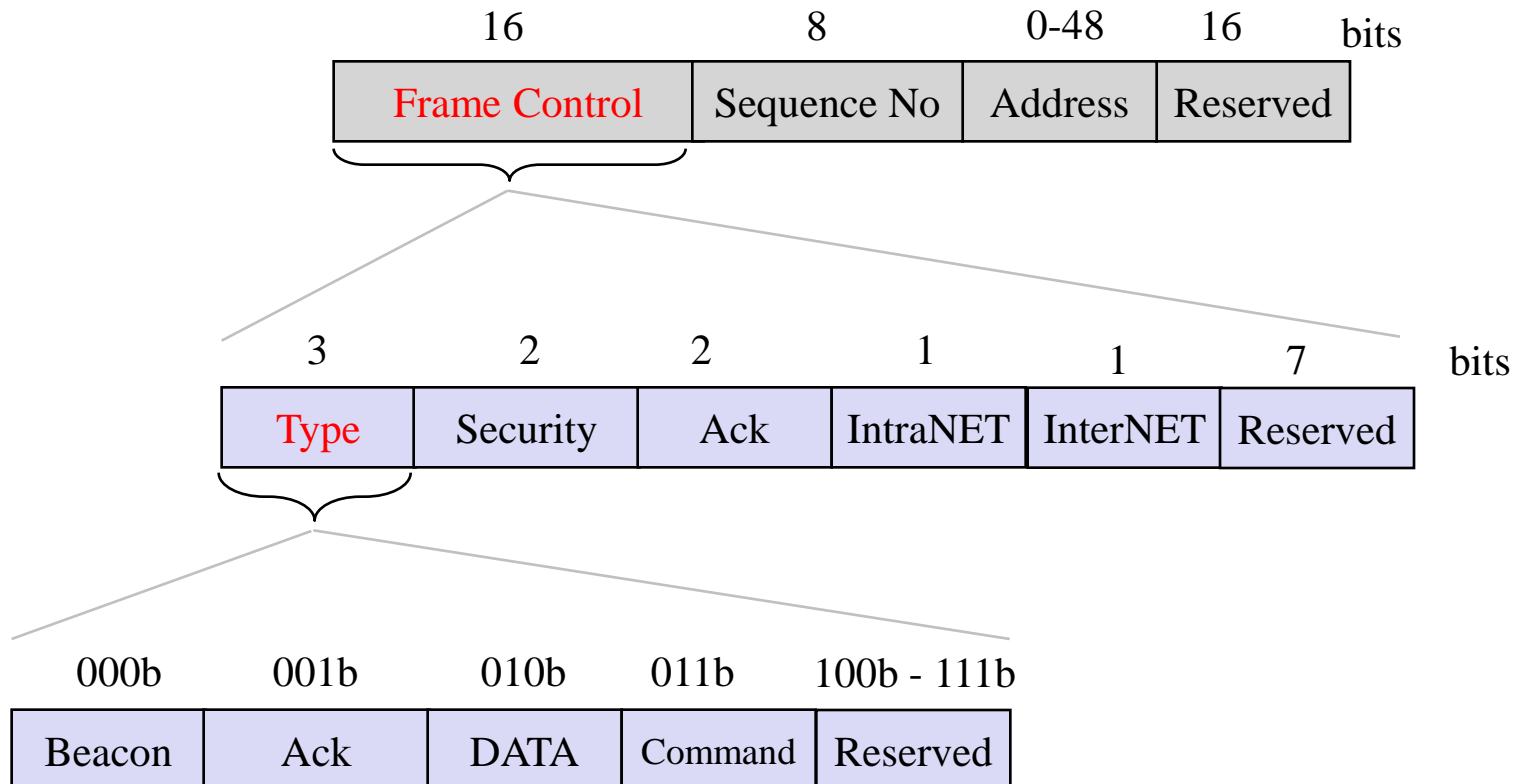

MAC Frame Structure (4)

- Frame control: Ack field

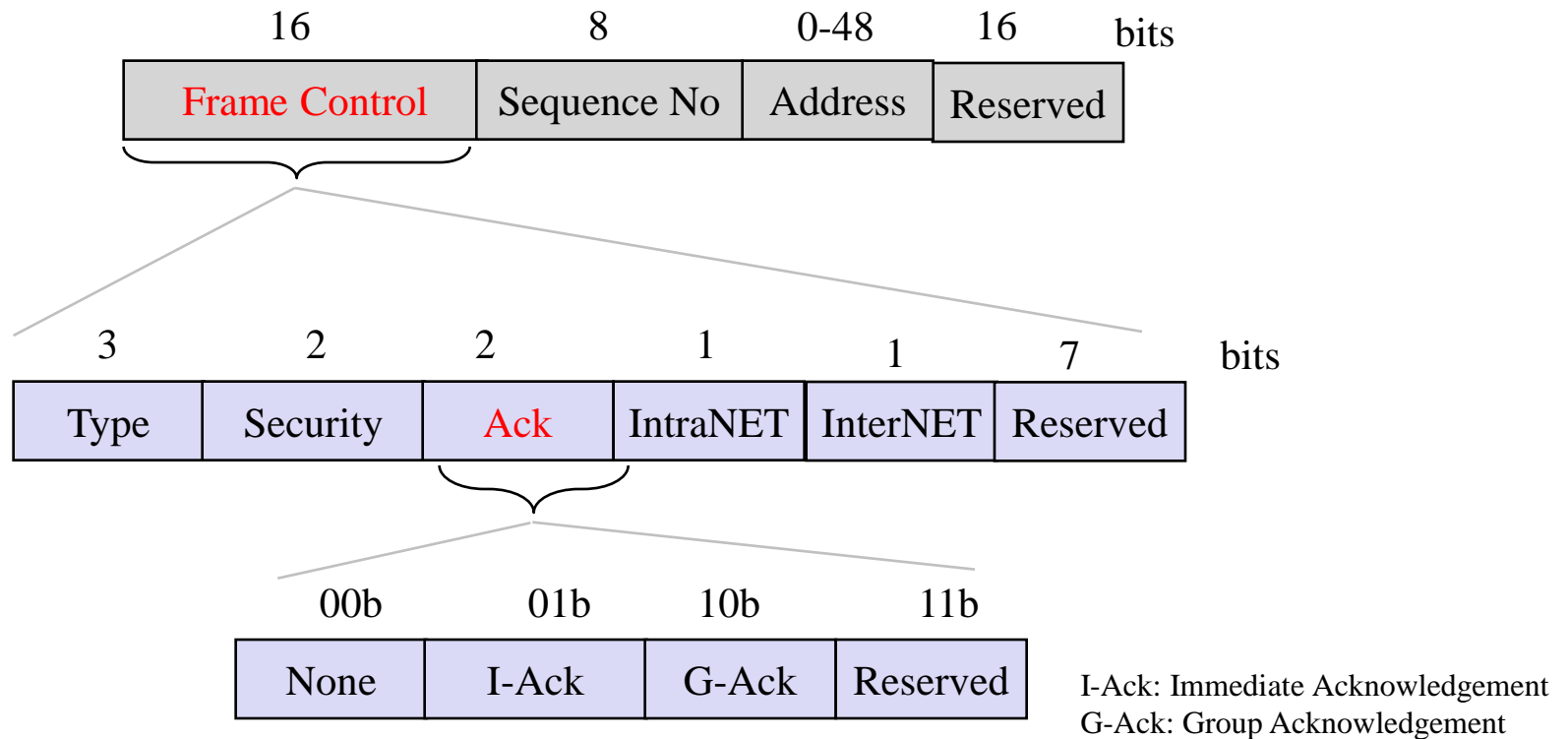

MAC Frame Structure (5)

- Address field

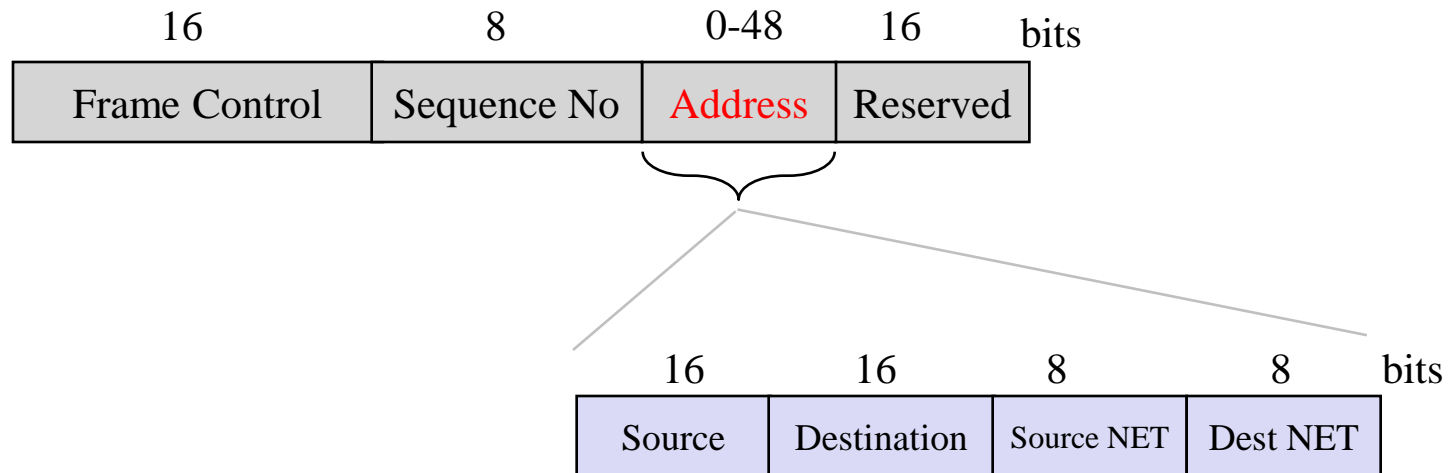

MAC Frame Structure (6)

- Beacon frame

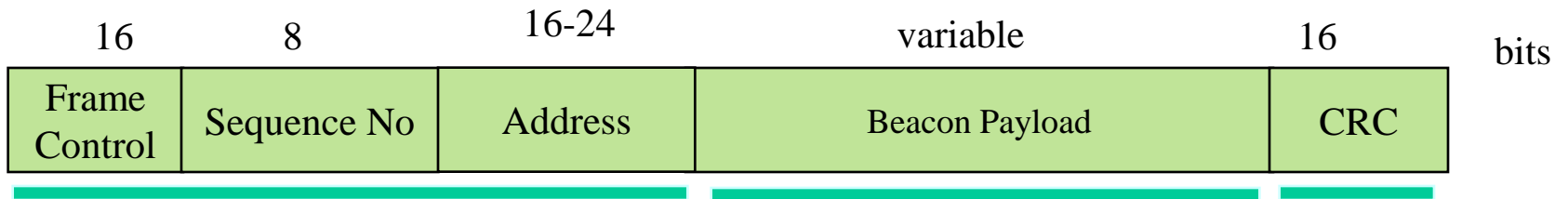

Beacon Payload: Network management, resource allocation etc.

- Command frame

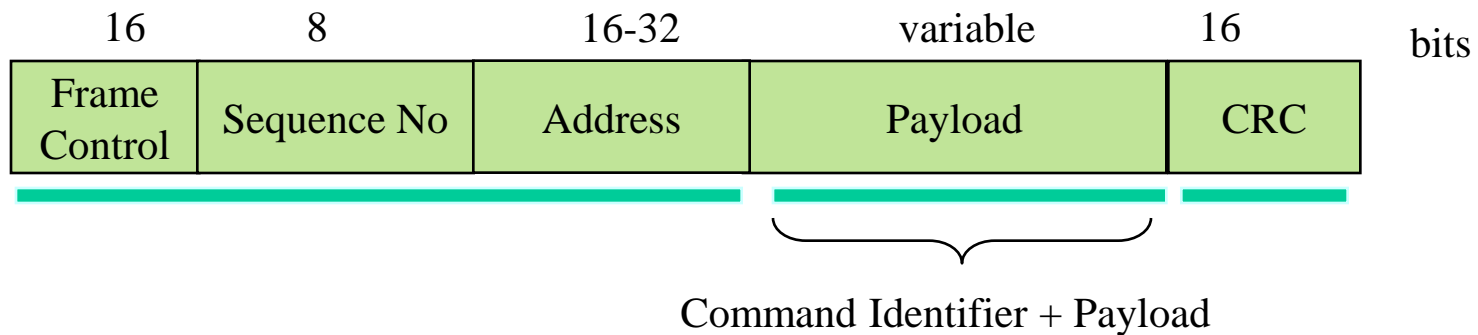

MAC Frame Structure (7)

- Immediate Acknowledgement (I-Ack)

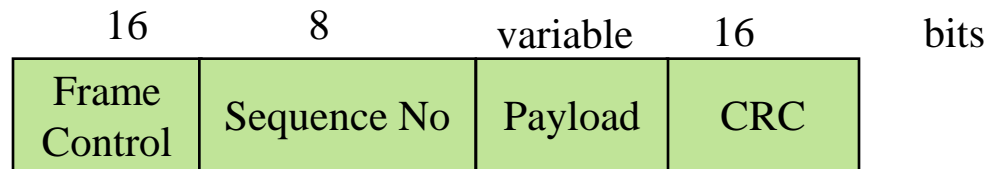

- Group Acknowledgement (G-Ack)

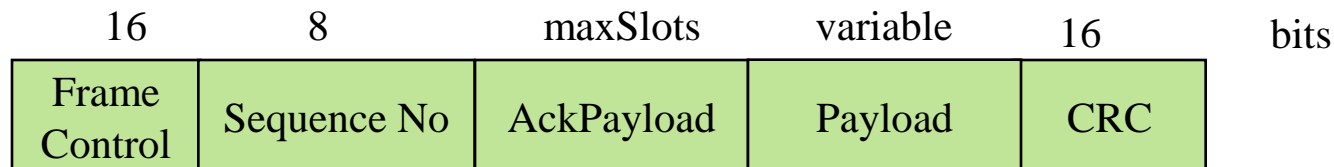

maxSlots: Maximum number of slots in a superframe

MAC Frame Structure (8)

- Frame control: Security field

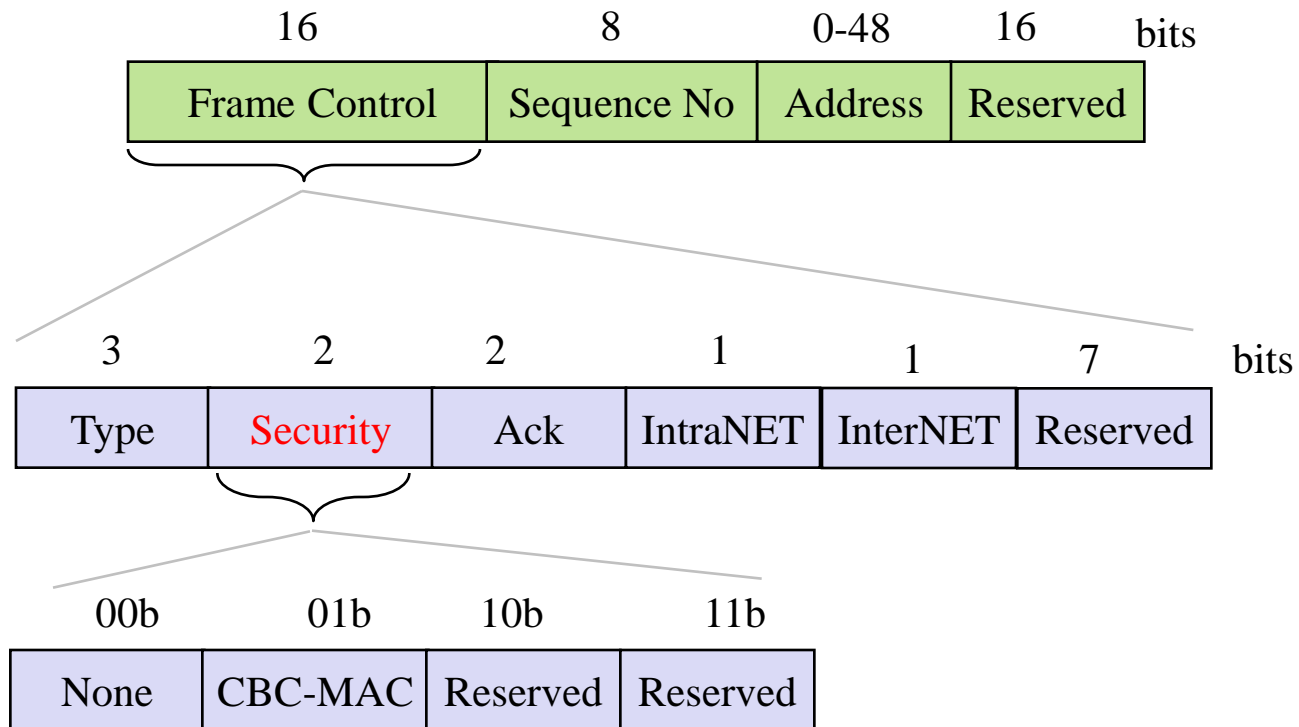

MAC Security

- IEEE 802.15.4 security specifications can be incorporated
- Security Levels
 - None: Packets are not secured
 - Level-1: Packets are encrypted
- Higher level of security is possible
 - Use of integrity codes

MAC Frame with Security

MAC frame without Security – Level 0 (None)

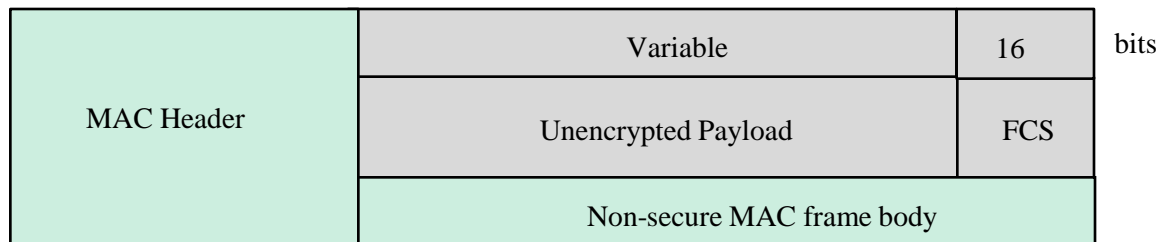

MAC frame with Security – Level 1 (Encrypted payload)

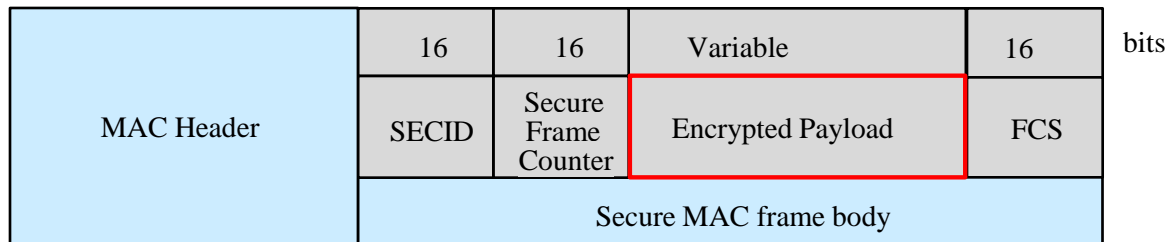

MAC Commands

Commands	Initiated by Coordinator	Initiated by Endpoint
Association request		X
Association response	X	
Disassociation notification		X
Data request	X	X
Net id Conflict	X	X
Emergency		X

Emergency commands can be set with unique identifiers: Fire, short circuit, battery critical, device malfunction etc.

Acknowledgement Provisioning (1)

- Acknowledgement (Ack) is necessary to notify the transmitting device about successful reception of data packet
- Three kinds of Ack policies are proposed
 - No Ack
 - Immediate Ack
 - Group Ack
- The ‘Ack’ field in control section of MAC frame defines the Ack policy to be used
- A two bit system is used to define the Ack

Type	Bits	Description
None	00	No ACK shall be sent by receiver
I-ACK	01	Immediate ACK- send by receiver immediately after receiving packet.
G-ACK	10	Group ACK- send by receiver after receiving several packets.
Reserved	11	Reserved

Acknowledgement Provisioning (2)

- Immediate Ack (I-Ack)
 - For uplink emergency communication in the beacon enabled mode, I-Ack is broadcasted with zero payload
 - For downlink data communication in the non-beacon enabled mode, the payload contains short notification information from coordinator to the endpoint
- Group Ack (G-Ack)
 - Used for normal communication in beacon mode
 - Broadcasted in the last time slot of a superframe
 - The AckPayload (in bits) is equal to the number of slots in the superframe
 - For downlink data communication, the Payload contains downlink data from coordinator to the endpoint
- Optionally, immediate Ack can be sent after every data packet using separate control and data channels

Performance Evaluation

- The assumptions are as follows
 - There are N endpoints in the network
 - All the endpoints are in star topology and within range of the coordinator
 - Packets are generated by Poisson model with avg. arrival rate λ
 - Each endpoint has one packet to transmit in one superframe
- Performance measures
 - Energy consumption
 - Lifetime
 - Success rate
 - Throughput and Utilization factor are investigated
 - Maximum network size estimation upon given frame size

Input Parameters

- Number of endpoints (N): 10,000
- Arrival rate (λ) : variable
- Superframe size : 256ms, 512ms
- Slots per superframe : 16, 32, 64, 128
- Slot duration: variable
- Packet size: 40 - 80 Bytes
- Battery capacity : 4000mAh
- Data Rate: 20Kbps, 30Kbps, 40Kbps
- Transmit power: 26mW
- Receive power: 13.5mW
- Sleep power: 1.5 μ W

Energy Consumption

- Average energy consumption per endpoint for superframe size of 512ms is shown below

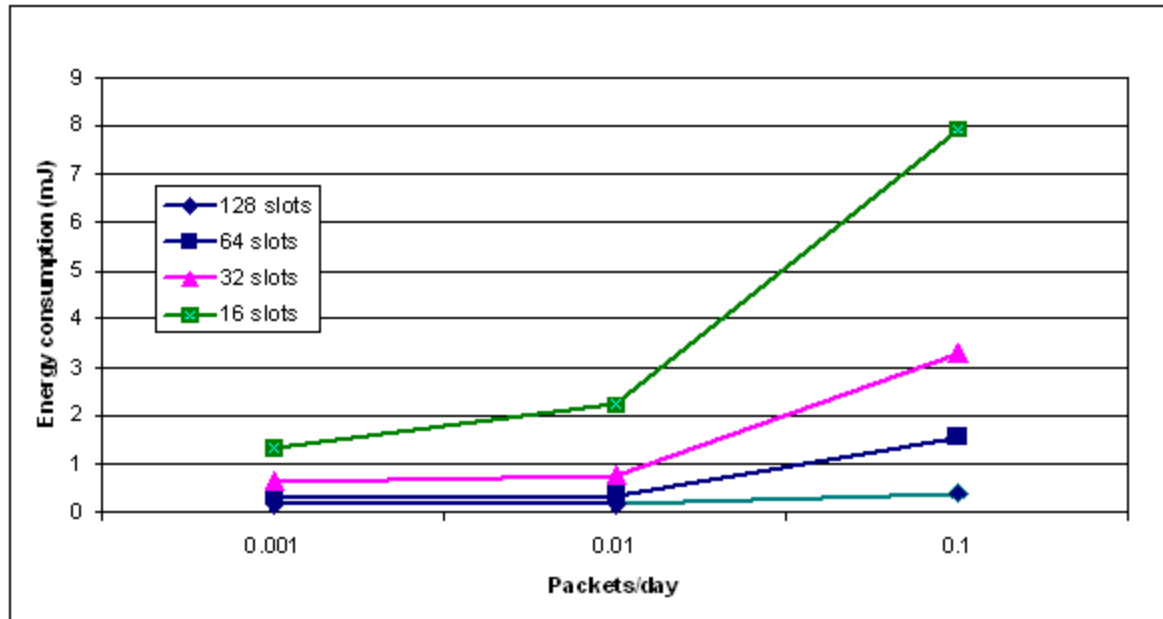

Energy Consumption

- Average energy consumption per endpoint for superframe size of 256ms is shown below

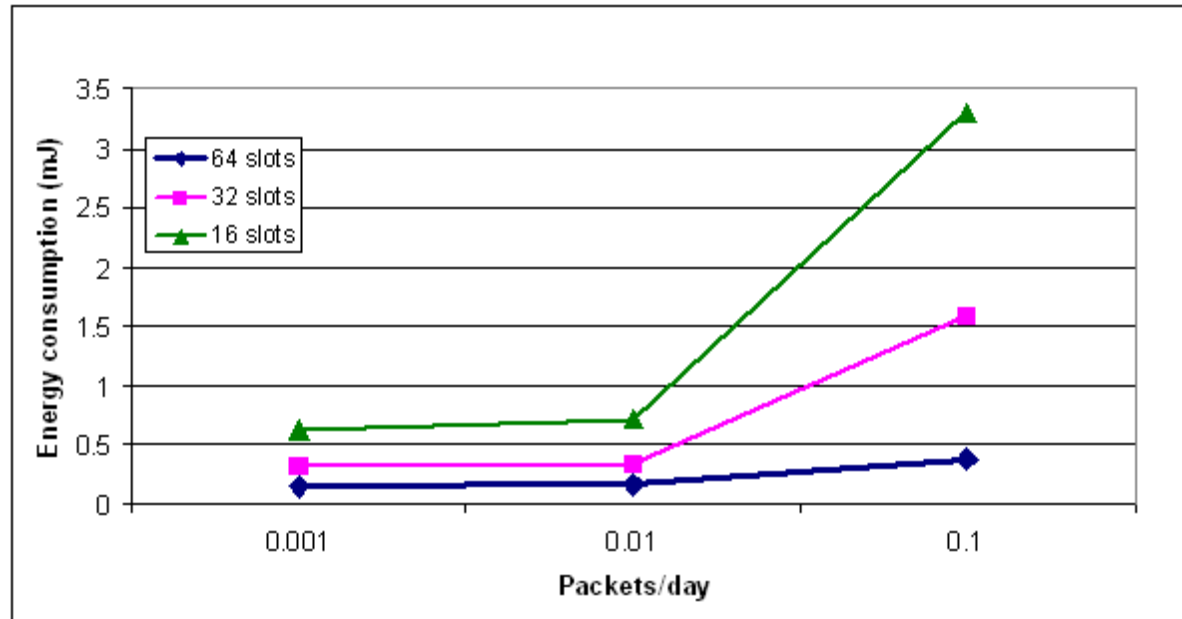

Lifetime

- Lifetime is shown for number of events per day
- For low events, smaller superframe duration has longer lifetime
- Energy used includes communication energy and sleep energy

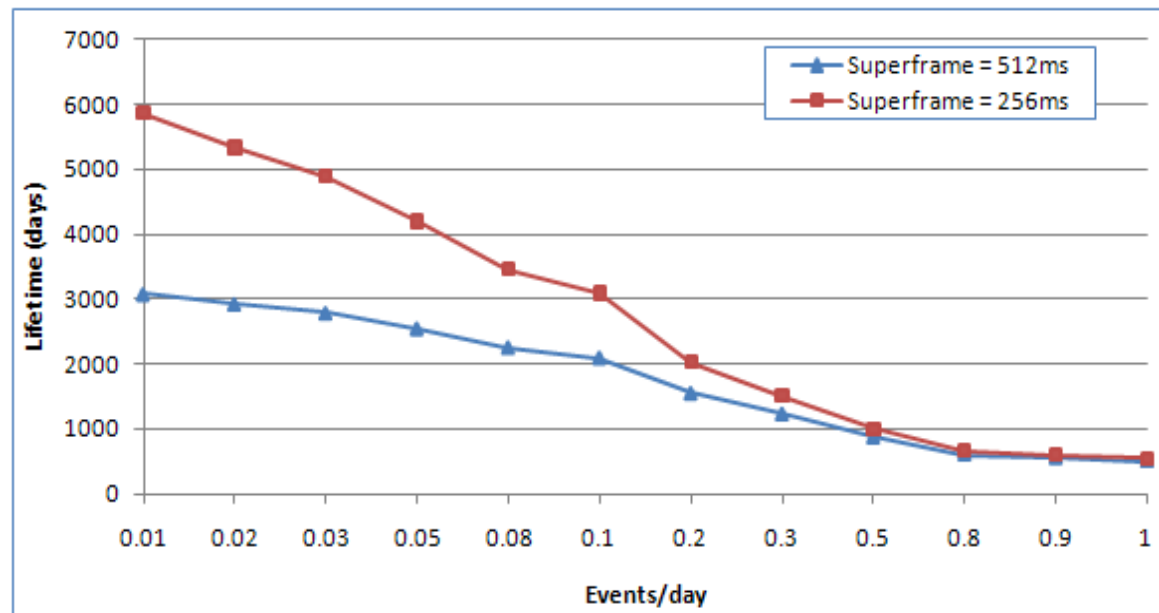

Success Rate Analysis

- Success rate for different arrival rate is calculated for total success upon total generated packets
- If arrival rate is low, we can use small superframe duration with less slots

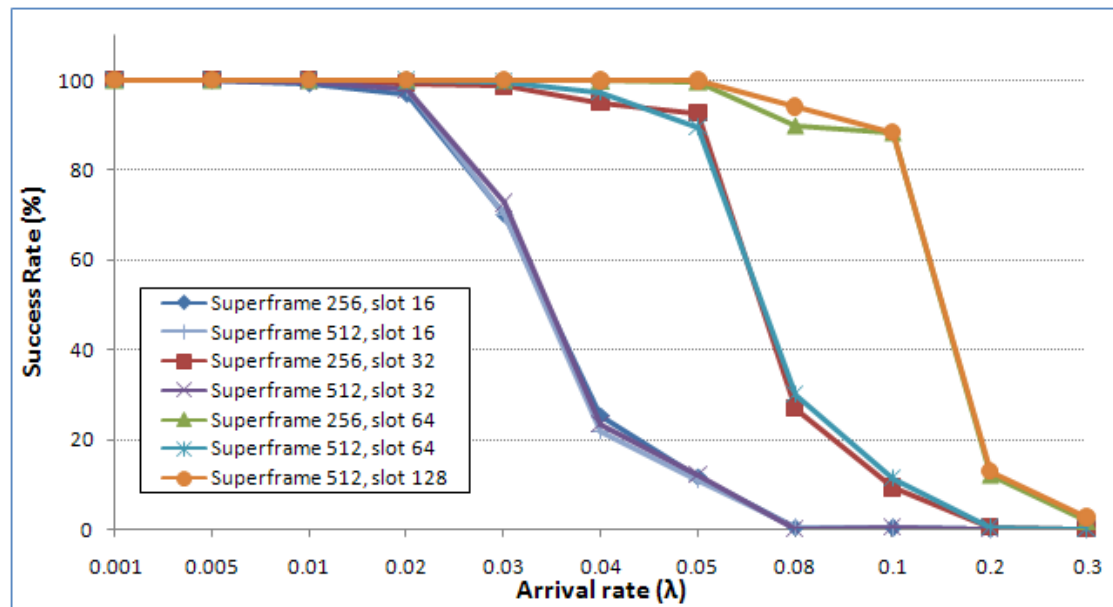

*More results are presented in Appendix -D

Throughput Analysis

- Throughput is calculated as number of successful packets per slot
- The number of slots, can be optimized for maximum throughput for particular arrival rate

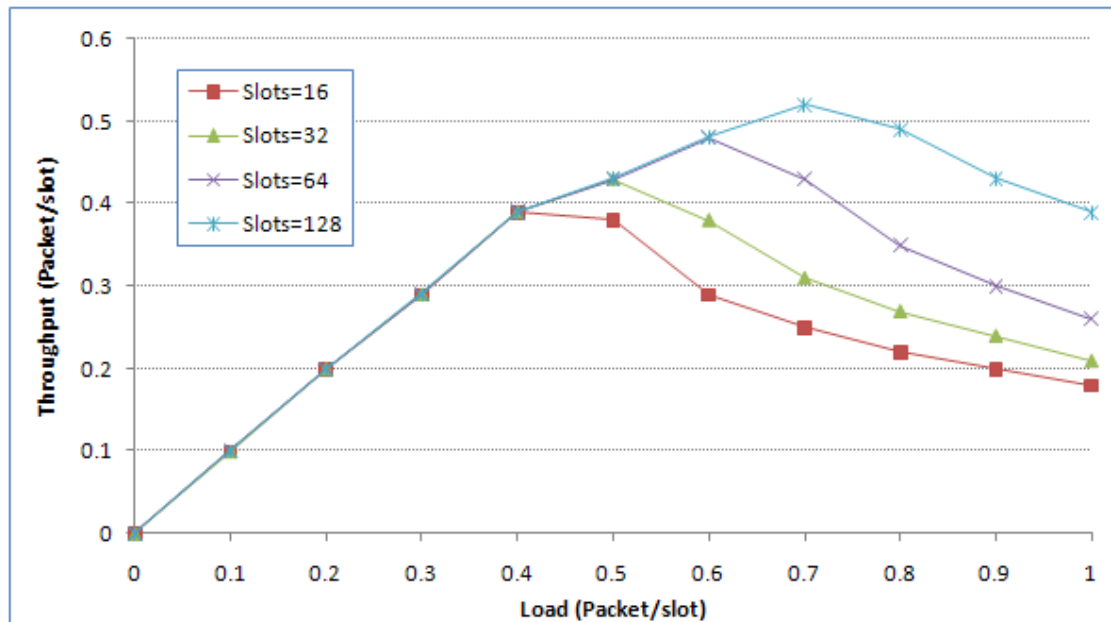

Estimated Network Size and Utilization

Slots/Superframe	Max Throughput	Max Network Size	Utilization Factor (%)
16	0.4	1000	0.040
		1500	0.027
		2000	0.020
		2500	0.016
		3000	0.013
		5000	0.008
		10000	0.004
32	0.44	1000	0.044
		1500	0.029
		2000	0.022
		2500	0.018
		3000	0.015
		5000	0.009
		10000	0.004

Slots/Superframe	Max Throughput	Max Network Size	Utilization Factor (%)
64	0.49	1000	0.049
		1500	0.033
		2000	0.025
		2500	0.0196
		3000	0.016
		5000	0.0098
		10000	0.005
128	0.53	1000	0.053
		1500	0.035
		2000	0.027
		2500	0.021
		3000	0.018
		5000	0.011
		10000	0.005

Energy Consumption Comparison

- The average power consumption of the proposed MAC is compared with some popular MAC protocols
- The power consumption is plotted against packet inter-arrival time
- The range of inter-arrival time varies from one day to three months

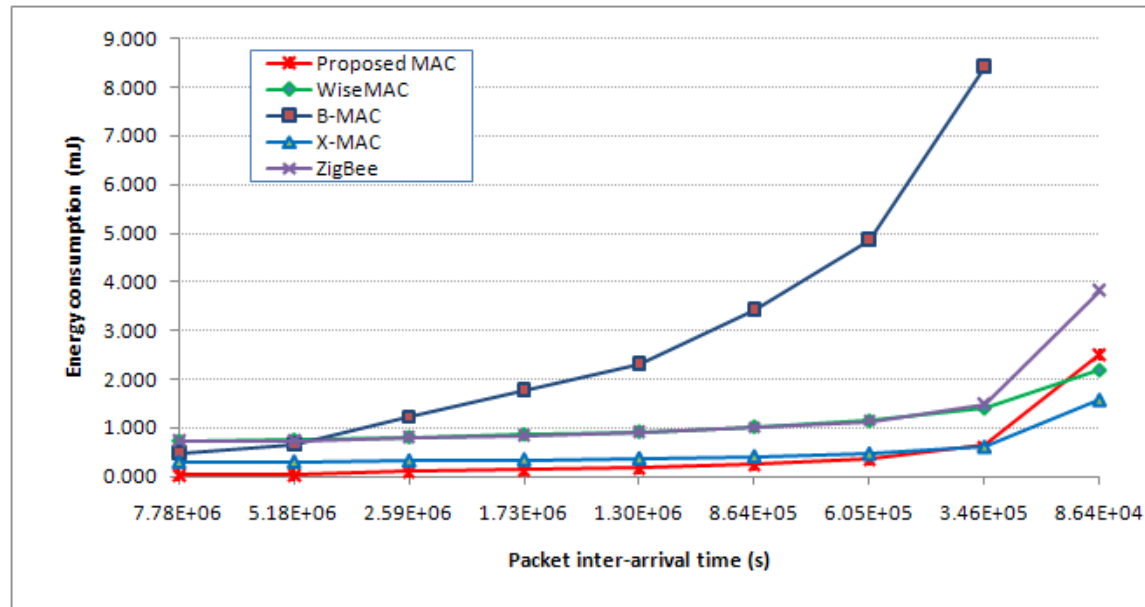

Conclusion

- The IEEE TG4k is formed to address the Low Energy Critical Infrastructure monitoring (LECIM)
- We propose a framed slotted Aloha MAC for LECIM
- Beacon enabled superframe based scheme is used
- Additionally a non-beacon enabled scheme using pure Aloha is proposed
- We analyzed energy consumption, lifetime and throughput for different frame sizes and found optimum network size and utilization factor
- We achieved good packet success rate
- The proposed MAC outperforms other MACs in terms of energy consumption
- Proposed protocol is simple to implement and flexible in terms of network size

The End

Thank You

Appendix – A:

Clock Synchronization and Guardtime Provisioning

Clock Synchronization and Guardtime Provisioning

- End point synchronizes to the coordinator through the beacon
- Clock accuracy of $\pm 20\text{ppm}$ or $\pm 40\text{ppm}$ can be used
- Propagation delay (T_p) is added to the actual slot duration to negate the delay occurred due to long distance
 - T_p values are presented in table below

Distance (km)	Propagation Delay (μs)
10	33.36
5	16.68
2	6.67
1	3.34
0.5	1.67
0.1	0.33

** Note: These results are upon 40 Kbps data rate*

Clock Synchronization and Guardtime Provisioning

- **Nominal Guardtime (GT_n)** is a time interval on a transmission channel at the end of every slot to differentiate between slot boundaries
- GT_n is taken as 1/10 of actual slot length

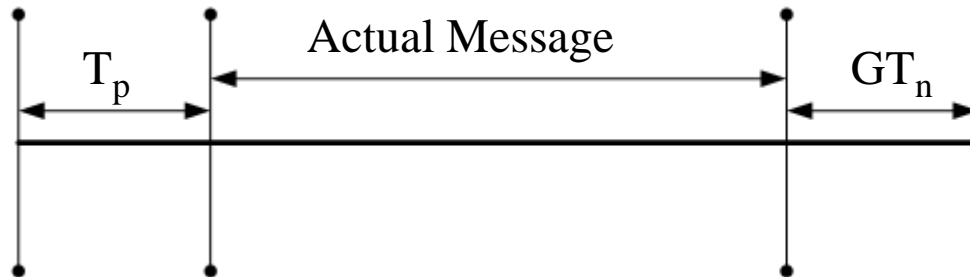

T_p : Propagation delay
 GT_n : Nominal guardtime

Appendix – B:

Frame Design

Superframe, Slot and Packet Size (1)

- Relations among frame size, slot size and packet size are shown
- We can estimate the probable frame size and packet sizes
- Data rate=40Kbps

Super frame size	512ms		256ms		128ms		64ms	
No. of Slots	Slot Duration (ms)	Packet Size (Bytes)	Slot Duration (ms)	Packet Size (Bytes)	Slot Duration (ms)	Packet Size (Bytes)	Slot Duration (ms)	Packet Size (Bytes)
16	32	160	16	80	8	40	4	20
32	16	80	8	40	4	20	2	10
64	8	40	4	20	2	10	1	5
128	4	20	2	10	1	5	0.5	2.5
256	2	10	1	5	0.5	2.5	0.25	1.25

11 Bytes

2 Bytes

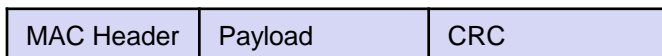

MaxPacket size=13Bytes + Payload



Non-usable

Superframe, Slot and Packet Size (2)

- Data rate=20Kbps

Super frame size	512ms		256ms		128ms		64ms	
No. of Slots	Slot Duration (ms)	Packet Size (Bytes)	Slot Duration (ms)	Packet Size (Bytes)	Slot Duration (ms)	Packet Size (Bytes)	Slot Duration (ms)	Packet Size (Bytes)
16	32	80	16	40	8	20	4	10
32	16	40	8	20	4	10	2	5
64	8	20	4	10	2	5	1	2.5
128	4	10	2	5	1	2.5	0.5	1.25
256	2	5	1	2.5	0.5	1.25	0.25	0.625

11 Bytes

2 Bytes

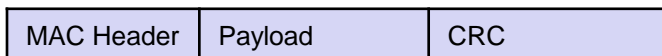

MaxPacket size=13Bytes + Payload

 Non-usable

Superframe, Slot and Packet Size (3)

- Data rate=10Kbps

Super frame size	512ms		256ms		128ms		64ms	
	Slot Duration (ms)	Packet Size (Bytes)	Slot Duration (ms)	Packet Size (Bytes)	Slot Duration (ms)	Packet Size (Bytes)	Slot Duration (ms)	Packet Size (Bytes)
16	32	40	16	20	8	10	4	5
32	16	20	8	10	4	5	2	2.5
64	8	10	4	5	2	2.5	1	1.25
128	4	5	2	2.5	1	1.25	0.5	0.625
256	2	2.5	1	1.25	0.5	0.625	0.25	0.3125

 Non-usable

11 Bytes

2 Bytes

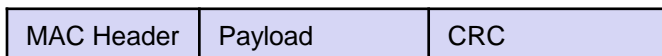

MaxPacket size=13Bytes + Payload

Appendix – C:

Downlink Communication Flow

Downlink Communication Process (1)

- **Downlink communication**
 - Downlink is for infrequent data communication from coordinator to the endpoints
 - Used when endpoints wake up for data communication

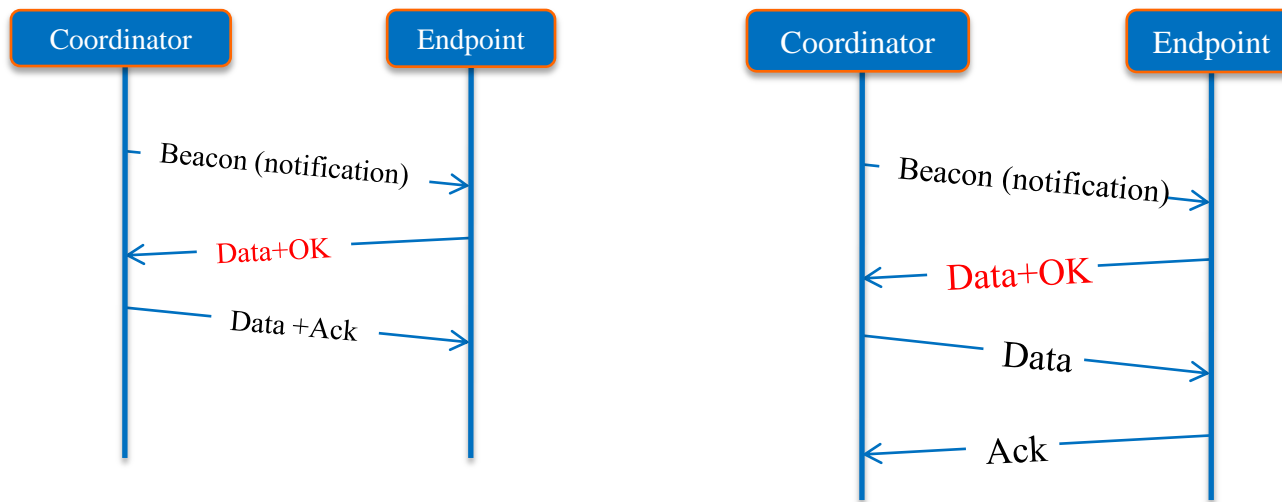

Downlink Communication Process (2)

- Downlink communication in non-beacon mode
 - Coordinator stores the data and waits for the endpoint to wake up
 - The endpoint wakes up for its scheduled data communication and transfers the data to the coordinator
 - The coordinator sends the downlink data piggybacking in the Ack frame
 - The endpoint sends the Ack confirming successful transmission

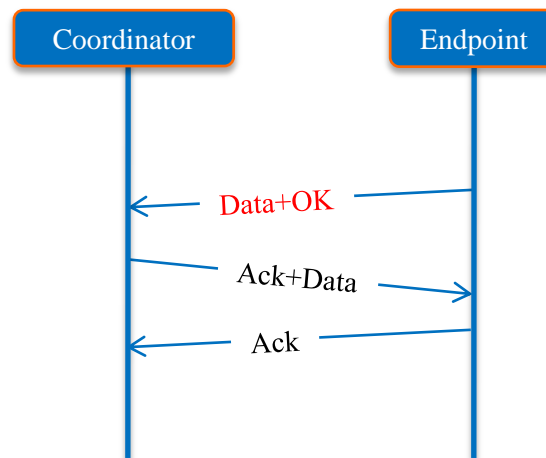

Appendix – D:

Success Rate

Success Rate Analysis (1)

- Success rate for different arrival rate is calculated
- The figure below shows when a packet is dropped after 5 retries
- The graph shows total successful packets upon total attempted packets using the framed slotted Aloha

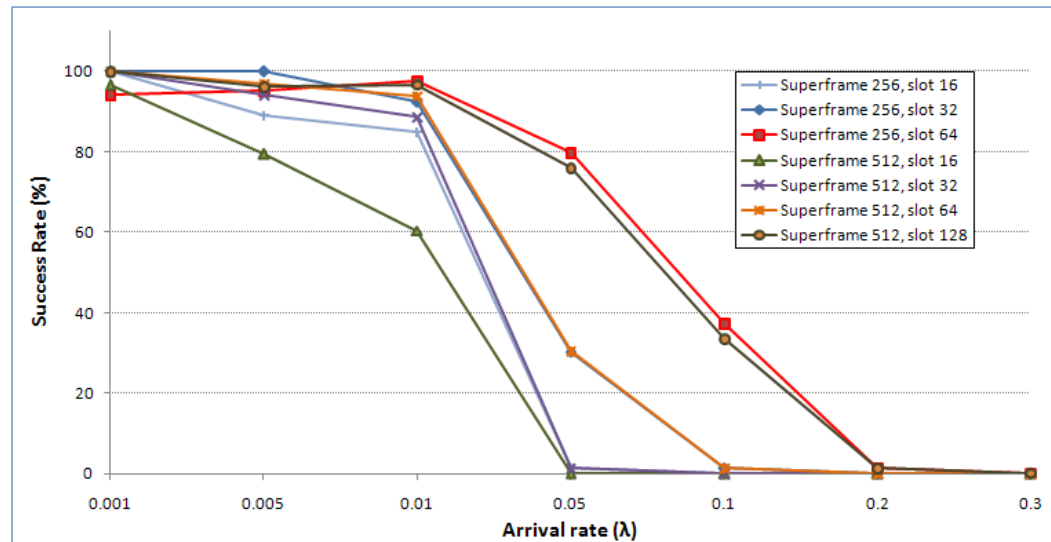

Success Rate Analysis (2)

- Success rate for different arrival rate is calculated
- The figure below shows when a packet is not dropped
- At low arrival rate, success rate reaches close to 100% due to availability of slots in each superframe

