

Project: IEEE P802.15 Working Group for Wireless Personal Area Networks (WPANs)

Submission Title: [Comment resolution for T-CID 78]

Date Submitted: [October, 2010]

Source: [Dae Ho Kim, Tae-Gyu Kang, Sang-Kyu Lim, Il Soon Jang, You Jin Kim] Company [ETRI],
[Sridhar Rajagopal] Company [Samsung Electronics]

Address [138 Gajeongno, Yuseong-gu, Daejeon, 305-700]

Voice:[+82-42-860-5648], FAX: [+82-42-860-5218], E-Mail:[dhkim7256@etri.re.kr]

Re: [Response to LB50 comments]

Abstract: [This document describes about comment resolution for T-CID 78]

Purpose: [Propose to]

Notice: This document has been prepared to assist the IEEE P802.15. It is offered as a basis for discussion and is not binding on the contributing individual(s) or organization(s). The material in this document is subject to change in form and content after further study. The contributor(s) reserve(s) the right to add, amend or withdraw material contained herein.

Release: The contributor acknowledges and accepts that this contribution becomes the property of IEEE and may be made publicly available by P802.15.

Comment resolution for T-CID 78

Dae Ho Kim
dhkim7256@etri.re.kr
ETRI

PHY Frame (PPDU) Format and PHY Header

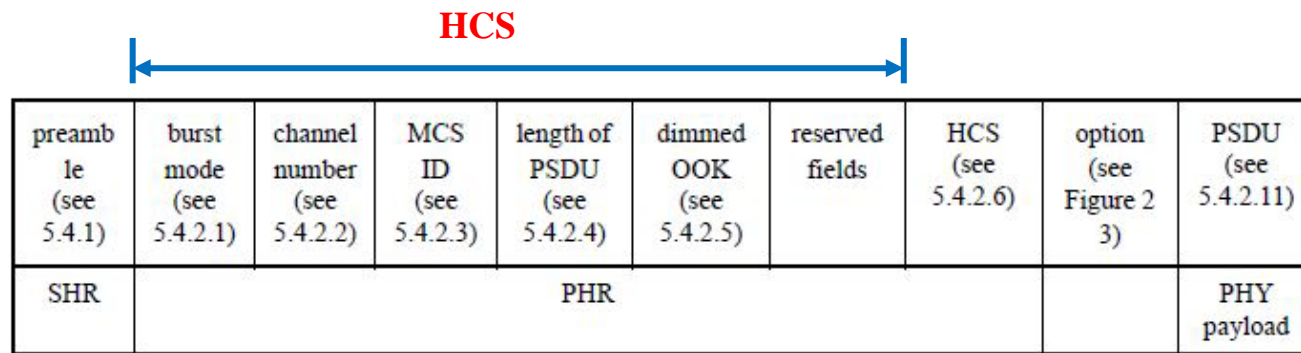


Figure 22—Format of the PPDU

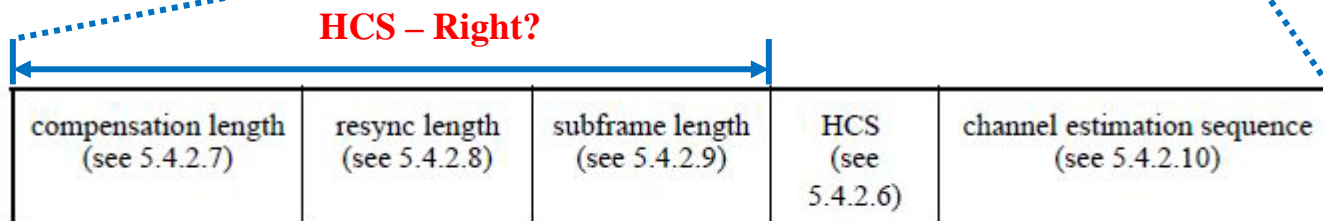


Figure 23—PPDU option fields

- * Additional comments
 - Need to define the exact calculation range of each HCS at subclause 5.4.2.6
 - Need to distinguish each HCS name

MAC Frame (MPDU) Format

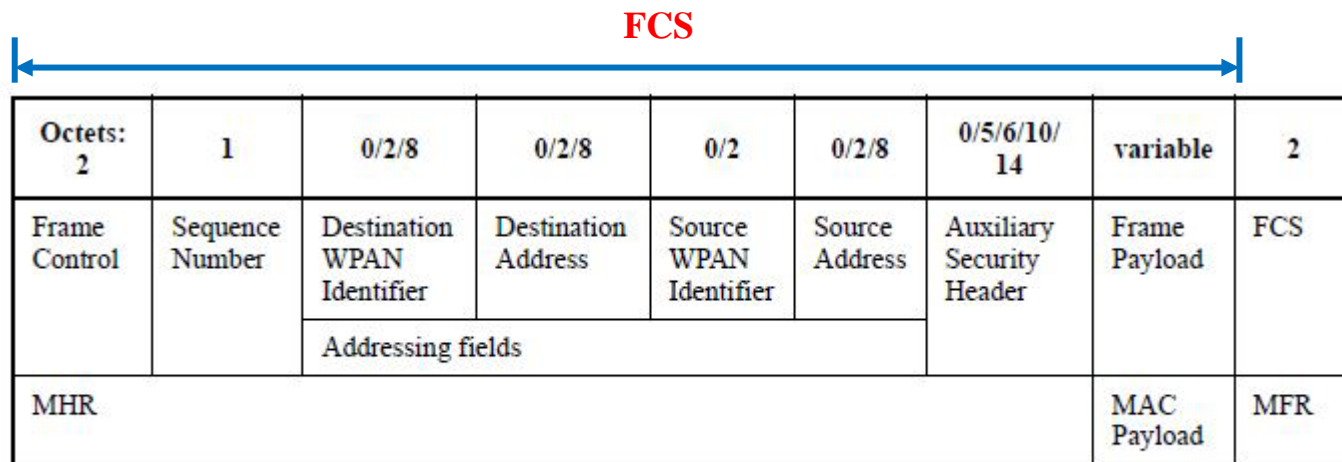


Figure 64—General MAC frame format

•Subclause 6.2.1.9 FCS field:

The FCS is calculated over the MHR and MSDU parts of the frame.

VLC Frame Format

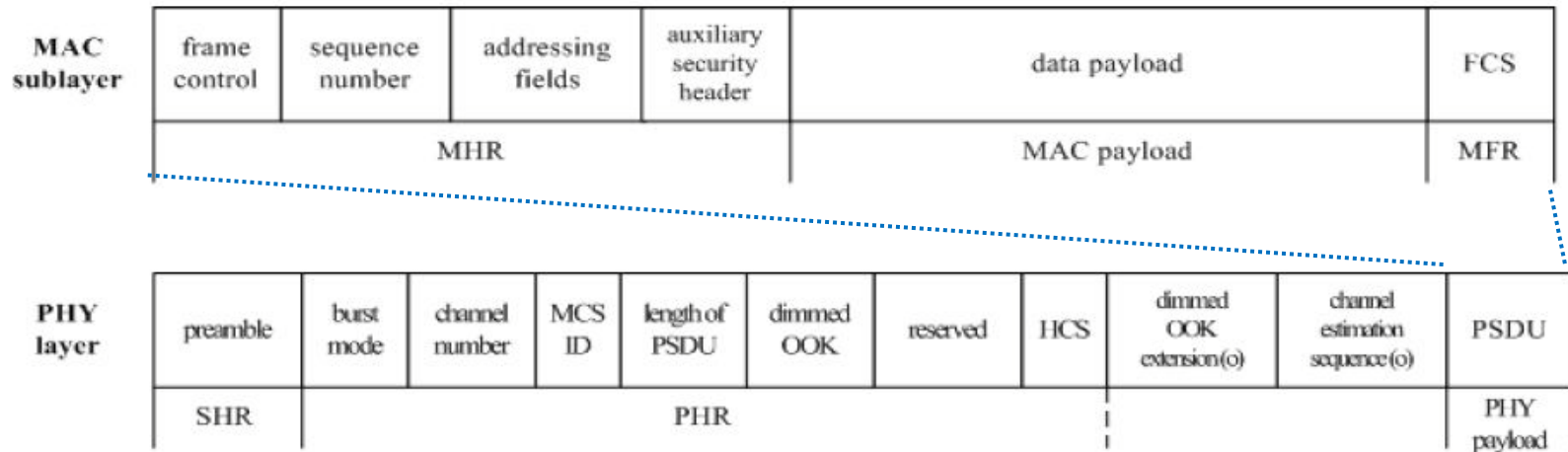
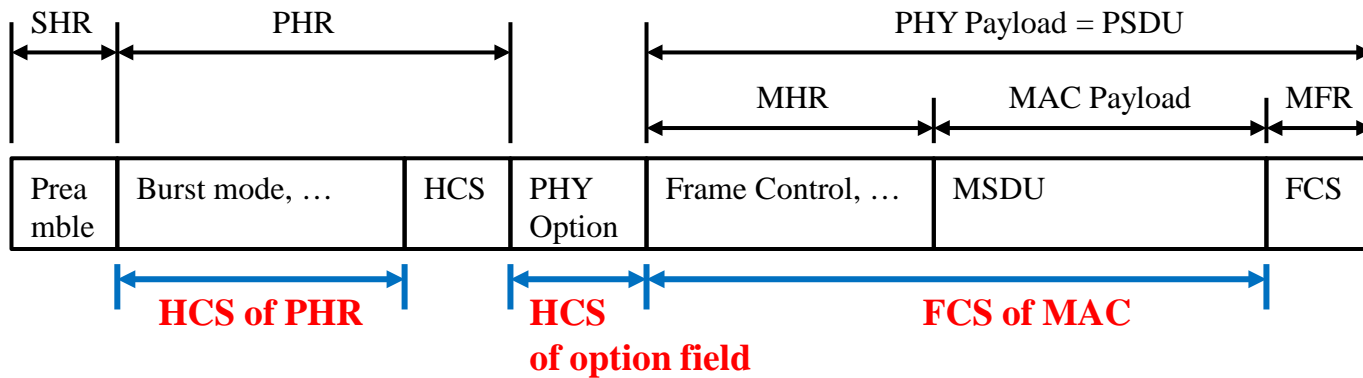


Figure 15—Schematic view of the data frame and the PHY frame

HCS of PHY and FCS of MAC



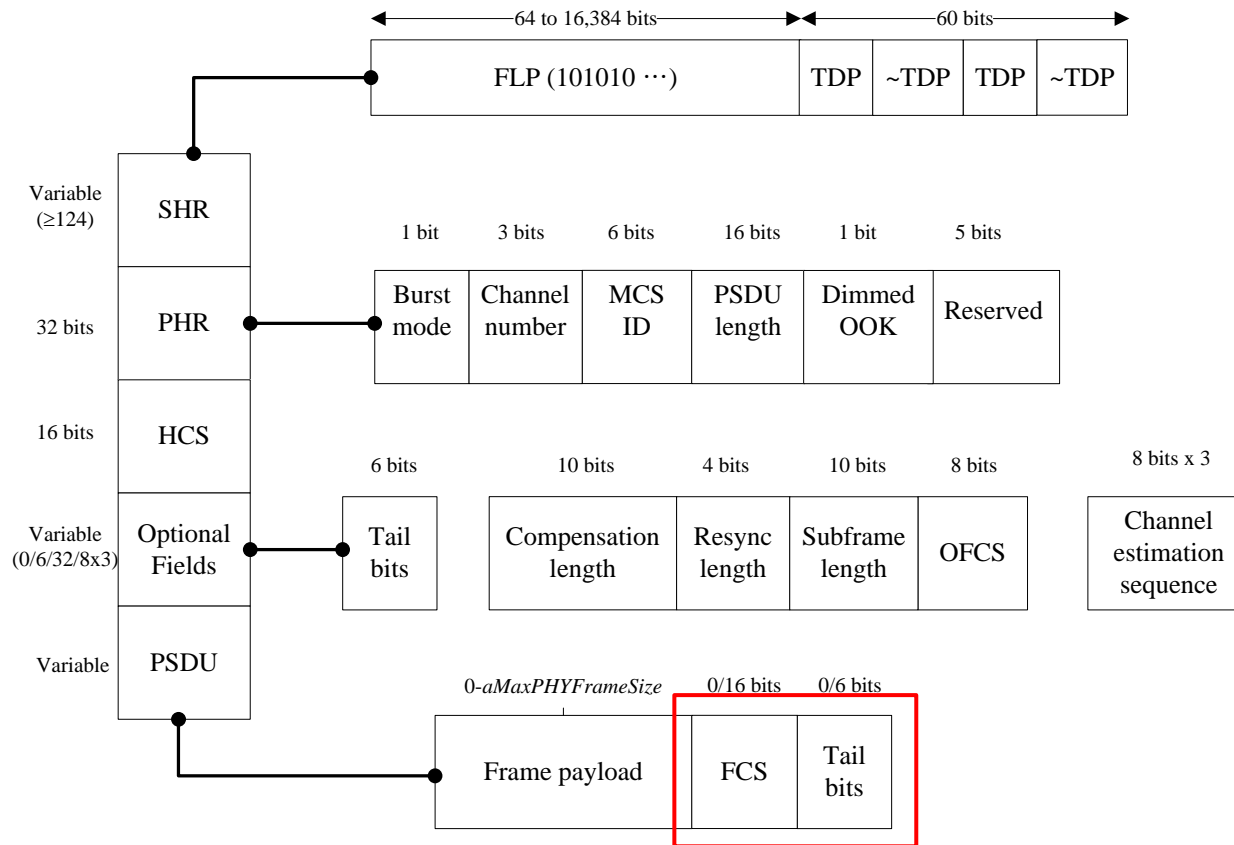
- The FCS of MAC covers the MHR and MSDU parts of the frame.
- The HCS of PHY covers the PHR

T-CID 78

- Comment
 - PSDU structure is not defined, provide a figure which shows how the PSDU is created

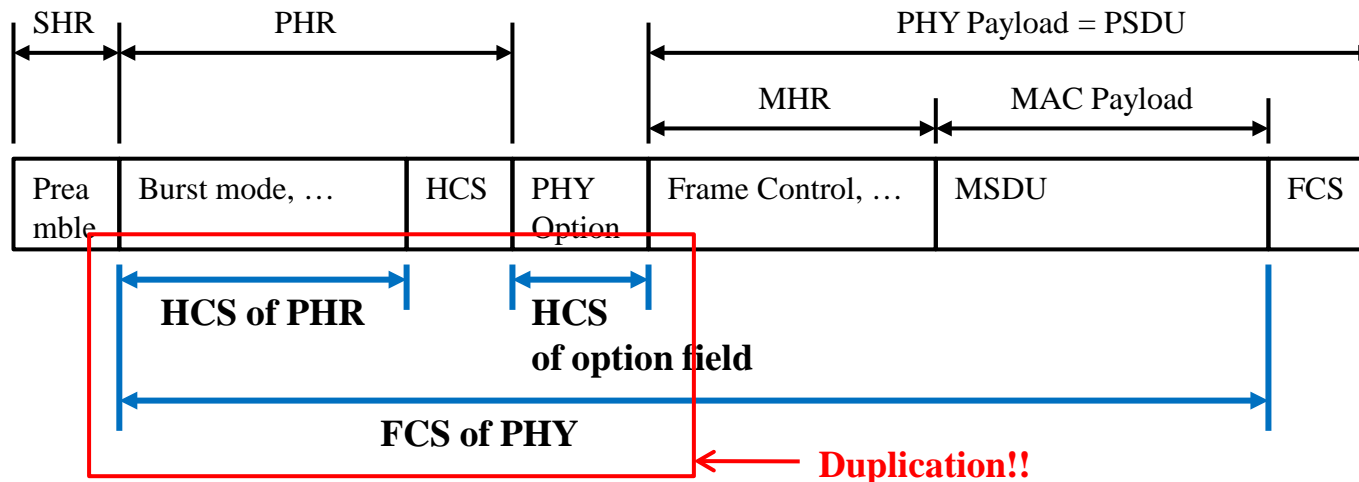


Figure for T-CID 78



Whose FCS and tail bits? MAC or PHY?

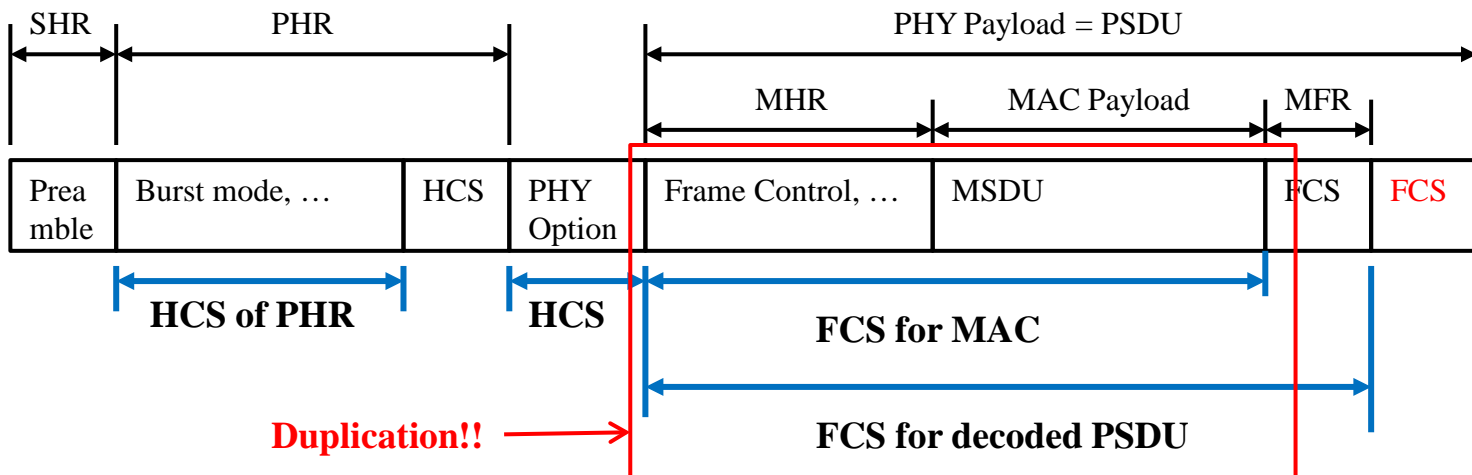
HCS of PHY header and FCS of PHY



- The general **FCS** covers **header and payload** of the frame.
- The FCS covers all fields of frame except itself. So we call Frame Check Sequence.
- The general **HCS** covers **only header (except itself)**. So we call Header Check Sequence.
- If FCS is a part of PHY, FCS has to cover the PHR and the PSDU.

FCS for decoded PSDU - 1

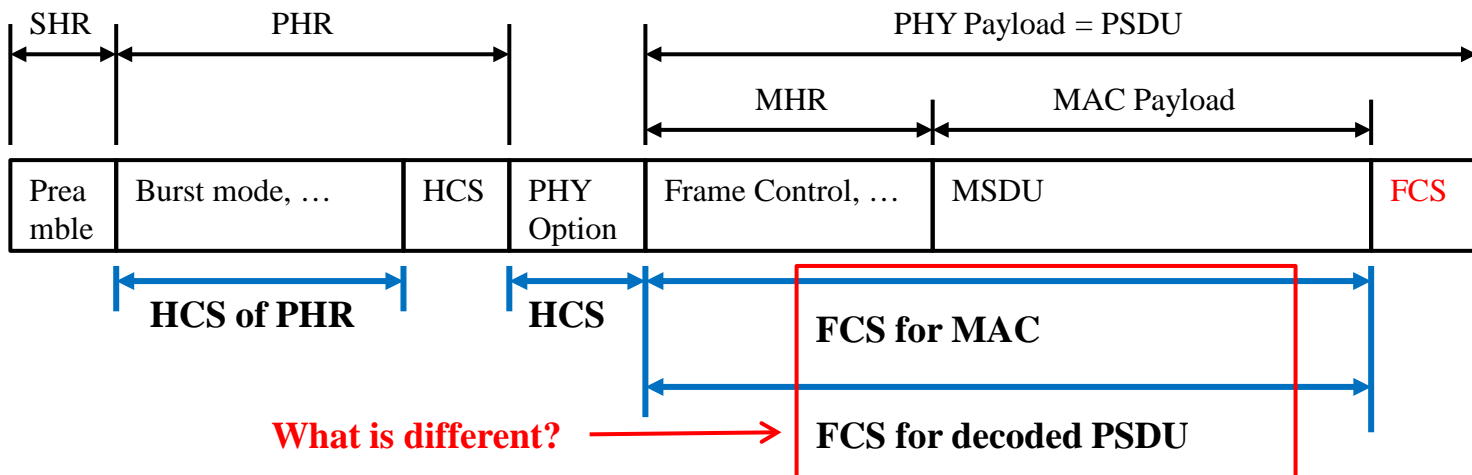
- The FCS is for checking the validity of the decoded PSDU.



- It does not need to error check for decoded PSDU. Decoded PSDU means MAC frame and because MAC frame is checked by FCS of MAC. And that is the role of MAC.
- The Data Link Layer(= LLC+MAC) provides the functional and procedural means to transfer data between network entities and **might provide the means to detect and possibly correct errors that may occur in the Physical Layer.**

FCS for decoded PSDU - 2

- The FCS is for checking the validity of the decoded PSDU.



- The FCS check can happen in the PHY or the MAC.
 - No “or”!! Need to exact define!!
 - FCS is a part of MAC, not PHY.

T-CID 78

- PSDU and MSDU
 - A SDU (Service Data Unit) is a unit of data that has been passed down from an higher layer to a lower layer and that has not yet been encapsulated into a protocol data unit (PDU) by the lower layer.
 - PSDU is a field of PHY and MSDU is a field of MAC.
 - PSDU and MSDU do not have a structure.
- Comment
 - PSDU structure is not defined, provide a figure which shows how the PSDU is created
 - Accept in principle.
 - Just we need to explain how the PSDU is created.
 - “The PSDU field carries the data of the PHY frame, such as MAC frame, and it has a variable length depending on the length of MAC frame. The MAC frame structure is described in 6.2.1 more in detail.”

Summary

- Current PHY frame format and MAC frame format is exactly right!!
 - We do not need to use a additional figure for resolution.
 - Figure for T-CID 78 makes a only confusion.
- If we want to add a tail bits, we have to change figure 22, figure 15, and so on.