

IEEE P802.15
Wireless Personal Area Networks

Project	IEEE P802.15.7 Task Group Visible-Light Communication (TG-VLC)		
Title	High-power high-bandwidth linear driving circuit for VLC applications		
Date Submitted	8th March 2010		
Source	Robert Baumgartner, Andreas Kornbichler, Joachim W. Walewski	Voice:	+49-89-636-45850
		Fax:	
		E-mail:	joachim.walewski@siemens.com
Re:			
Abstract	We discuss the challenge of the linear trans-conductance amplification of broadband VLC signals, which, for instance, is paramount for color-shift keying, a modulation format described in the forthcoming standard IEEE 802.15.6. We discuss potential solutions and discuss our implementation that has successfully been used in high-speed VLC transmission up to 200 Mb/s.		
Purpose	Contribution to the reference list of IEEE 802.15.7 D2		
Notice	This document has been prepared to assist the IEEE P802.15. It is offered as a basis for discussion and is not binding on the contributing individual(s) or organization(s). The material in this document is subject to change in form and content after further study. The contributor(s) reserve(s) the right to add, amend or withdraw material contained herein.		
Release	The contributor acknowledges and accepts that this contribution becomes the property of IEEE and may be made publicly available by P802.15.		
Document #	15-10-0151-01-0007		

1. Nomenclature

1.1. Abbreviations

AC	Alternating current
ADC	Analog-digital converter
BP	Band-pass filter
BJT	Bipolar-junction transistor
DAC	Digital-analog converter
DC	Direct current
DMT	Discrete multitone
LED	Light-emitting diode
PD	Photodiode
QAM	Quadrature amplitude modulation
Rx	Receiver
SFDR	Spurious free dynamic range
SNR	Signal-to-noise ratio
TCA	Trans-conductance amplifier

TIA	Trans-impedance amplifier
T _x	Transmitter
VLC	Visible-light communications

1.2. Symbols

Symbol	Declaration
C_{ds}	Coupling capacitance [F]
L_S	Coupling inductance [H]

2. Description of challenge

The VLC link model we base our discussion on is shown in Figure 1. In VLC applications combining lighting and communication, one critical part of such a link is the TCA. This is especially true if one intends to employ multilevel modulation formats, e.g. CSK or QAM on DMT. Such a TCA has to meet the following needs.

- High linearity (SFDR usually larger than the optical SNR).
- Adjustment of LED bias current independent of VLC AC signal.
- Medium to high output power over large baseband bandwidths (e.g., ~ 300 mW over 50 MHz [Vučić, 2009])
- Small footprint and short wiring. This is important, since the signal bandwidth of such LEDs is generally limited by the inductivity of their internal conductors [Minh, 2009], and adding more cabling would decrease the bandwidth even more.
- Widely adjustable input impedance, so that multiple amplifiers can either be operated in a line or star topology [Shrestha, 2009].
- For development purposes the circuit designed has to be ideally configurable out of widely available parts.
- Matching to the very low differential impedance of LEDs.
- High power efficiency.

The last bullet point is elucidated in the following. Even high-power LEDs like the white LED module shown in Figure 2 are characterized by very low differential impedances. In this module six thin-film LEDs are connected in series and arranged under one collimation lens. The combined output reaches 400 lm, enough to provide illumination for a 1-m²-sized reading area [EN12464-1, 2003]. The static voltage-current characteristic of this module is shown in Figure 3. Notice the very small slope of the curve for driving currents higher than 300 mA (a typical bias current for this device is 700 mA [Vučić, 2009]). This translates into a very small differential resistance of 2 Ω. This is not only true for the static characteristics of the module. Frequency-dependent impedance measurements revealed a real resistance of around 3 Ω for frequencies up to several 10's of MHz.

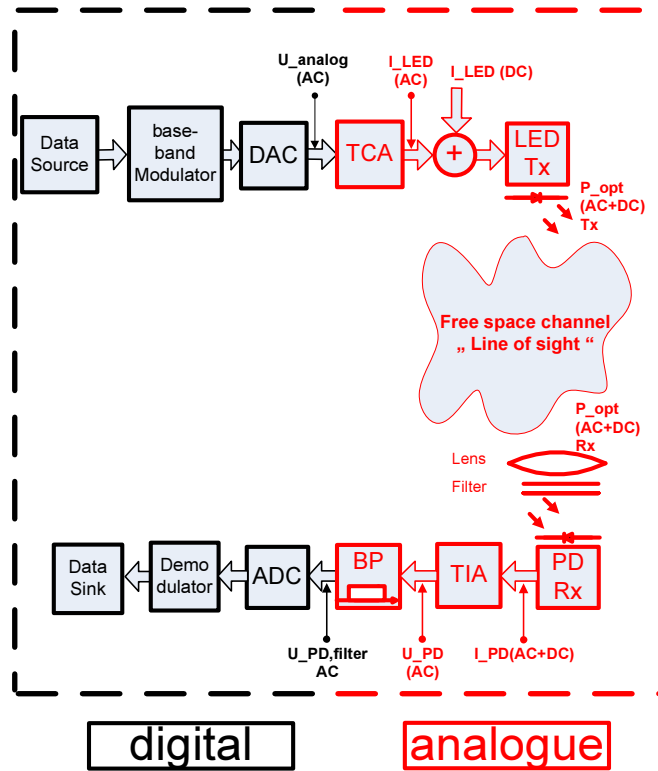

Figure 1: Block diagram of a VLC PHY. In case of a CSK link all analogue parts and the ADCs and DACs have to be tripled.

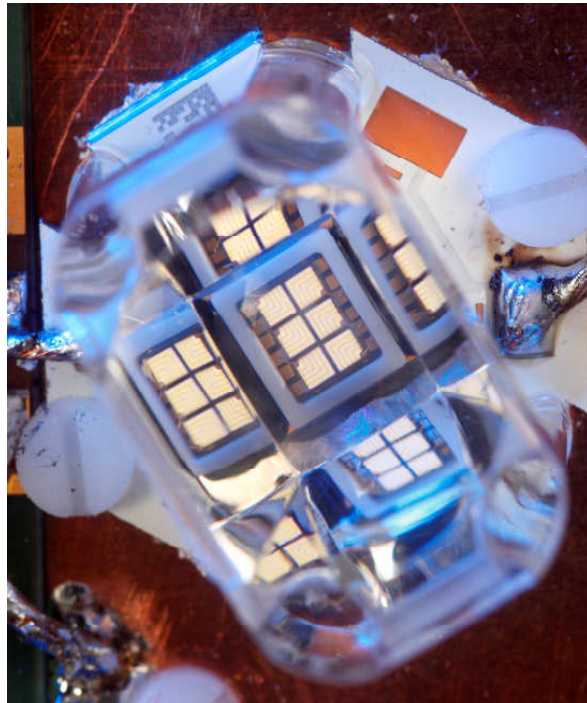

Figure 2: Top view of a high-power LED for illumination purposes. The LED module, comprised of six thin-film LED chips, is seen through imaging optics that is mounted on top of the module. Due to the magnification of the imaging optics the six thin-film chips that are operated in series are readily distinguished. Photo courtesy of Stefan Nerreter, Siemens AG.

If one uses conventional high-frequency amplifiers for modulating the VLC signal onto the LED bias current (see Figure 1), one is faced with issue that their output impedance is usually 50Ω or higher. In order to make use of such amplifiers one is thus forced to use impedance transformers. However, such transformers are generally expensive, come with a bandwidth much smaller than the 10's of MHz needed for our purposes, and they are also characterised by a rather large footprint. OPAs for the MHz region do, on the other hand, possess appreciably low impedances (e.g., LT1210), but both their linearity and their bandwidth are not sufficient for our application.

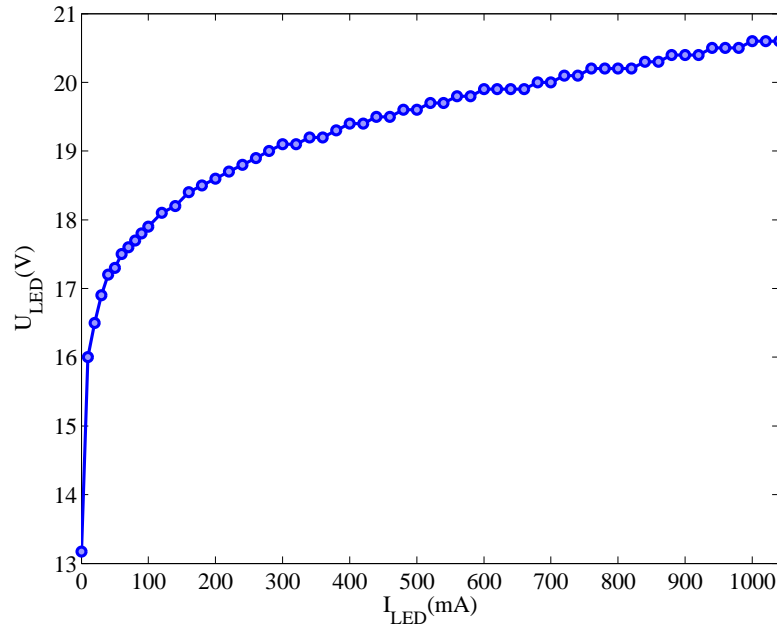

Figure 3: Voltage-current characteristic of the high-power LED module displayed in Figure 2.

3. Solutions

In the following we discuss our chosen circuit architecture for the task at hand. The input impedance is kept high, so that the circuit can be used in linear tap geometries [Shrestha, 2009]. Also, as discussed previously, the output impedance is kept low.

An exemplary circuit layout is shown in

Figure 4. The architecture we propose consists of at least two amplification stages, one TIA (1) and one TCA (2). The TIA stage boosts the voltage of the signal, while the TCA amplifies the current. The input impedance of the TCA is rather large, so that commercial TIA amplifiers featuring rather high output impedances can be used. In our implementation we successfully use DSL amplifiers for the first stage. Ideally, they feature a larger bandwidth than that of the second stage and that of the LED, so that it does not limit the overall bandwidth of the driving circuit.

In order to make the driving circuit power efficient one should use amplifier classes at least of the efficiency offered by class AB for the amplification stages. Another amplifier class that lends itself for this task is class D, which also offers significantly higher power efficiency than class AB. In our example we used two high-power BJTs

(3) in a typical tandem class-AB configuration. Two current sources (4) and a BJT-based circuit (5) optimizes the voltage applied to the bases of the two power transistors (3).

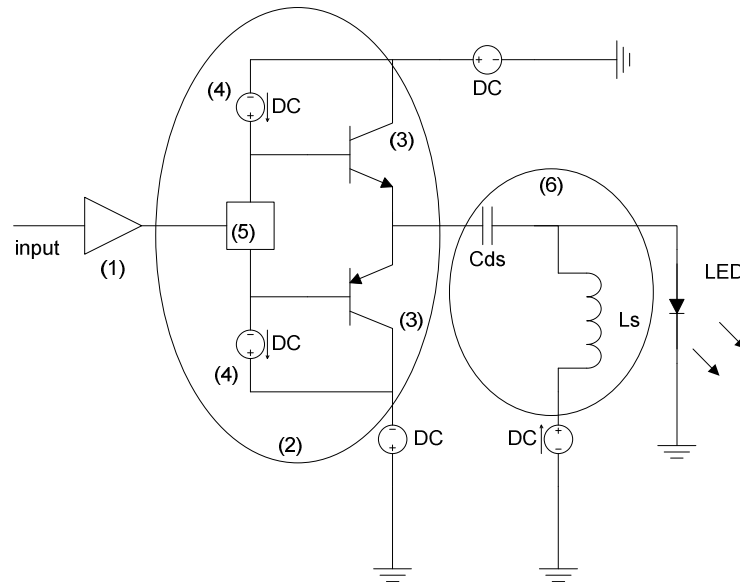

Figure 4: Schematic view of the driving circuit devised for VLC communication with the LED module shown in Figure 2. (1) TIA with a high-resistance input; (2) Current-amplification stage; (3) Class-AB amplifier; (4) current source; (5) voltage-stabilization for the input of the current-amplification stage; (6) bias T, superimposing the AC output from the amplifier stages onto the DC current supply.

The AC portion of the output from the trans-conductance amplifier stage is superimposed onto an LED bias current supplied by a dedicated current source. The superposition is accomplished by aid of a bias T (6), consisting of a capacitance (C_{ds}) and an inductance (L_s). Other AC/DC adding approaches can of course also be used. This decoupling of amplification of AC and bias-current generation is salient to our approach for two main reasons. First, it allows us to operate the LED module without the driving circuit being switched on at all. Since the latter also consumes energy when no VLC signal is applied to its input, this provides the option of additional power saving during communication-free periods. Second, it allows us to choose the bias current independently of the VLC signal. This can be of interest for, e.g., amplitude-dimming schemes as advocated in the forthcoming IEEE 802.15.7 [IEEE 802.15.7, 2010].

When designing a driving circuit along the rules outlined above it is paramount to make the inductance of the circuit path between the output of the TCA stage (2) and LED module as low as possible, so that this segment is not becoming the bandwidth-limiting element of the driving circuit.

Within the project OMEGA (<http://www.ict-omega.eu>) we produced 24 analogue transmitter sets consisting of the driving circuit in Figure 4 and the LED module in Figure 2. We consistently reached optical 3-dB modulation bandwidths with maximum modulation indexes around 0.7 and SFDRs better than 20 dBc. In Figure 5 three exemplary modulation spectra are shown.

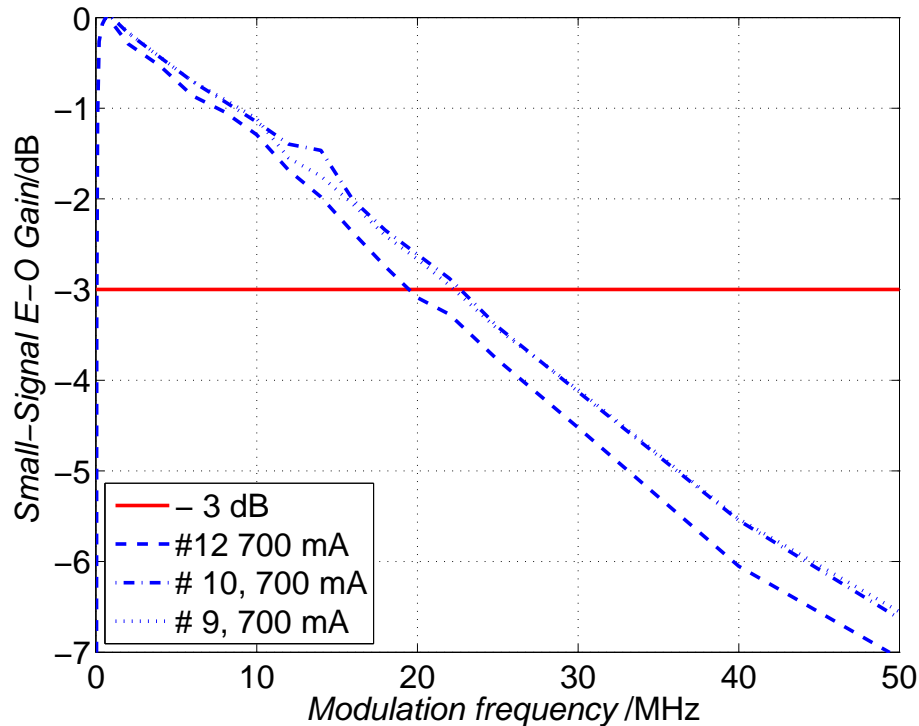

Figure 5: E-O modulation spectra for three optical transmitters based on the LED module in Figure 2 and the driving circuit in Figure 4. These transmitters were arbitrarily chosen from a series production of 24 transmitters.

Acknowledgment

The authors also gratefully acknowledge Florian Hockel, Osram GmbH, for donating the high-power LED modules used in our work and for providing technical support regarding their use.

The work presented here received partial funding from the European Commission's Seventh Framework Programme FP7/2007-2013 under grant agreement n° 213311, also referred to as OMEGA. The authors acknowledge the contributions of OMEGA colleagues. This information reflects the consortiums view, and the Commission is not liable for any use that may be made of any of the information contained therein.

References

EN12464-1, "Lighting of indoor work places," 2003.

IEEE 802.15.7, "IEEE Standard for Information technology — Telecommunications and information exchange between systems — Local and metropolitan area networks — Specific requirements — Part 15.7: Wireless Medium Access Control (MAC) and Physical Layer (PHY) Specifications for Visible Light Wireless Personal Area Networks (WPANs)," Draft D1, 27th February 2010

H. L. Minh, D. O'Brien, G. Faulkner, L. Zeng, K. Lee, D. Jung, Y. Oh, and E. T. Won, „100-Mbit/s NRZ Visible Light Communications Using a Post-Equalized White LED," IEEE Photonics Technology Letters, Vol. 21, No. 15, pp. 1063-1065, 2009

Amita Shrestha, "Visible-Light Communication Demonstrator: System modeling and analogue distribution network design," Master's Thesis, Jacobs University, 2009

Jelena Vučić, C. Kottke, Stefan Nerreter, A. Büttner, Klaus-Dieter Langer, and Joachim W. Walewski, "White Light Wireless Transmission at 200+ Mb/s Net Data Rate by Use of Discrete-Multitone Modulation," IEEE Photonics Technology Letters, Vol. 21, No. 20, pp. 1511-1513, 2009