Project: IEEE P802.15 Working Group for Wireless Personal Area Networks (WPANs)

Submission Title: [PSSK and Regulatory information for ETRI's proposal]

Date Submitted: [Jan 2009]

Source: [Jaehwan Kim, Jeong-Yeol Oh, Cheolhyo Lee, HyungSoo Lee, Jae-Young Kim]

Company: [ETRI]

Address: [ETRI, 138 Gajeong-ro, Yuseong-gu, Deajeon, 305-700, South Korea]

Voice: [+82-42-860-5338], **FAX:** [+82-42-823-5218]

E-Mail: [kimj@etri.re.kr, jyoh@etri.re.kr, cle7@etri.re.kr, hsulee@etri.re.kr, jyk@etri.re.kr]

Re: []

Abstract: PSSK and Regulatory information for ETRI's proposal .

Purpose: This document is intended as a proposal for addressing the requirements of the TG6 standard.

Notice: This document has been prepared to assist the IEEE P802.15. It is offered as a basis for discussion and is not binding on the contributing individual(s) or organization(s). The material in this document is subject to change in form and content after further study. The contributor(s) reserve(s) the right to add, amend or withdraw material contained herein.

Release: The contributor acknowledges and accepts that this contribution becomes the property of IEEE and may be made publicly available by P802.15.

Objective for Modulation

- Goal
 - Power efficient modulation
 - Bandwidth efficient modulation
- Phase silence shift keying
 - Compromise between power efficient and bandwidth efficient modulation
 - PSSK achieves this by using orthogonal phase spaces

Phase Silence Shift Keying

- Combination of PPM and PSK
 - For M-ary PSSK
 - The first bit decides the silence period
 - The remained bits are represented by (M-1)-ary PSK
 - 8-PSSK signal constellation

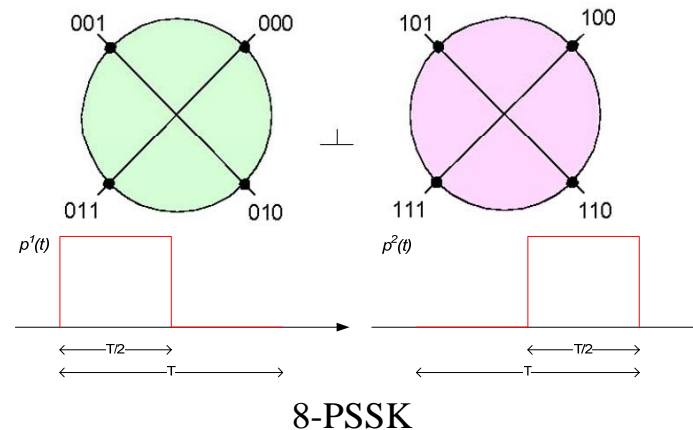
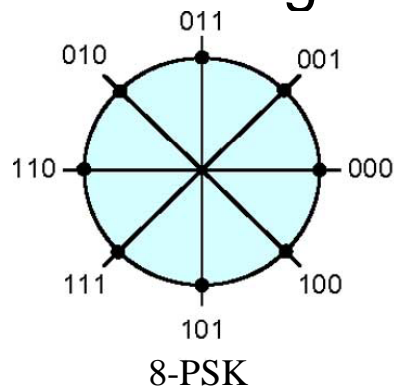

- Minimum distance between two adjacent signals of PSSK is smaller than that of PSK

Performances (1)

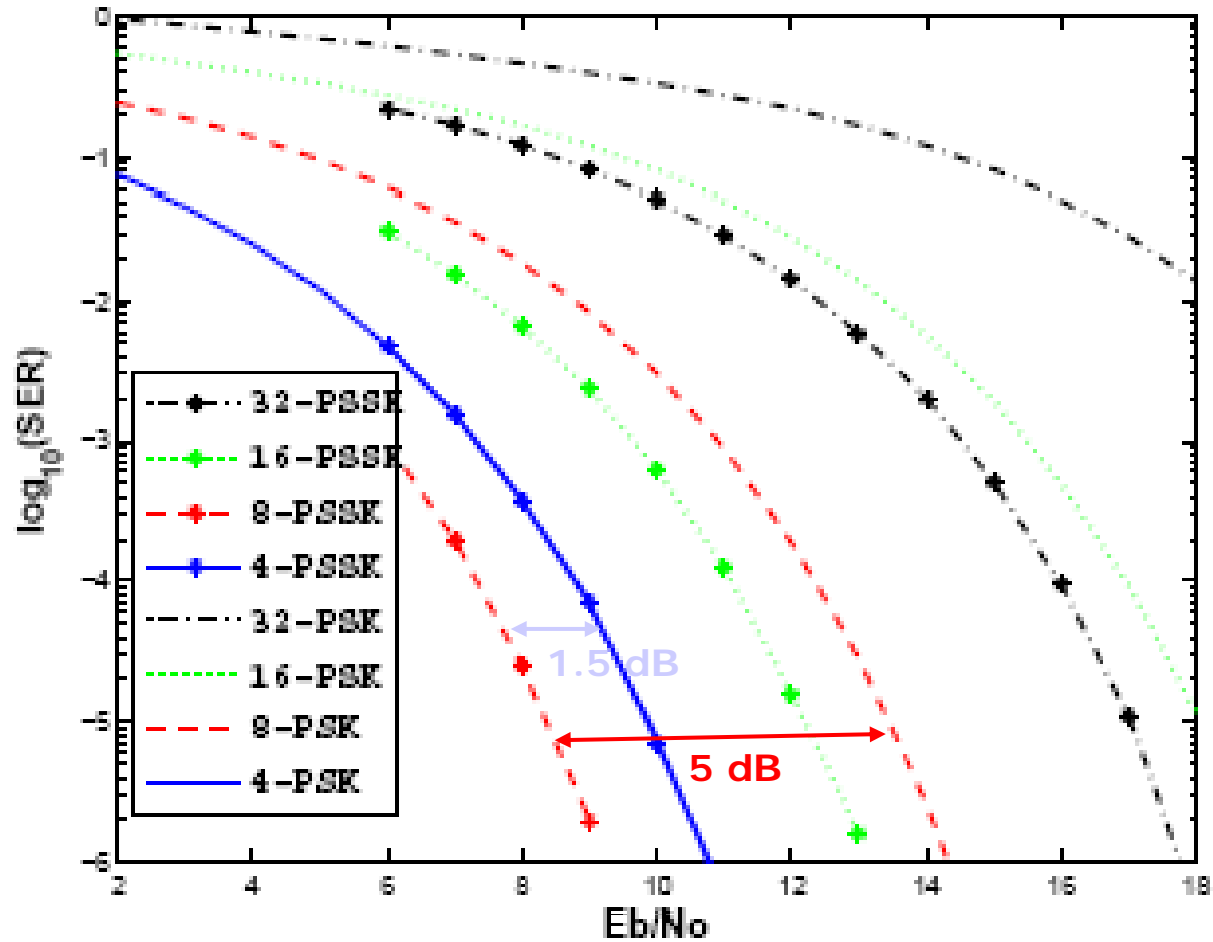

Performances (2)

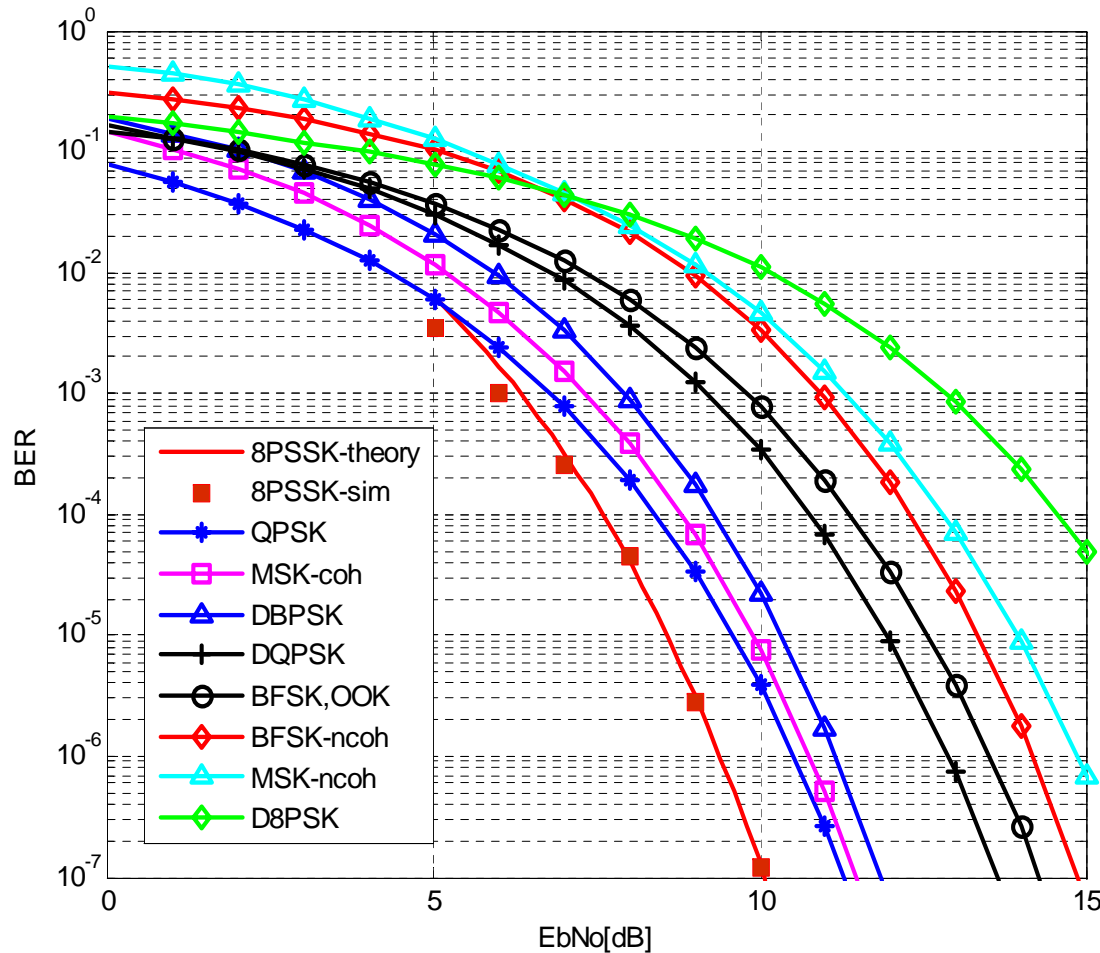

	BW (bps/Hz)	BER (10^{-6})	Receiver
8PSSK	0.75	9 dB	Coh.
QPSK	1	10.5 dB	Coh.
BPSK	0.5	10.5 dB	Coh.
2FSK	0.4	13.5 dB	Coh.
MSK	0.75	10.5 dB	Coh.
GMSK	0.88	12.2 dB	Coh.

Performances (3)

- Spectral re-growth property

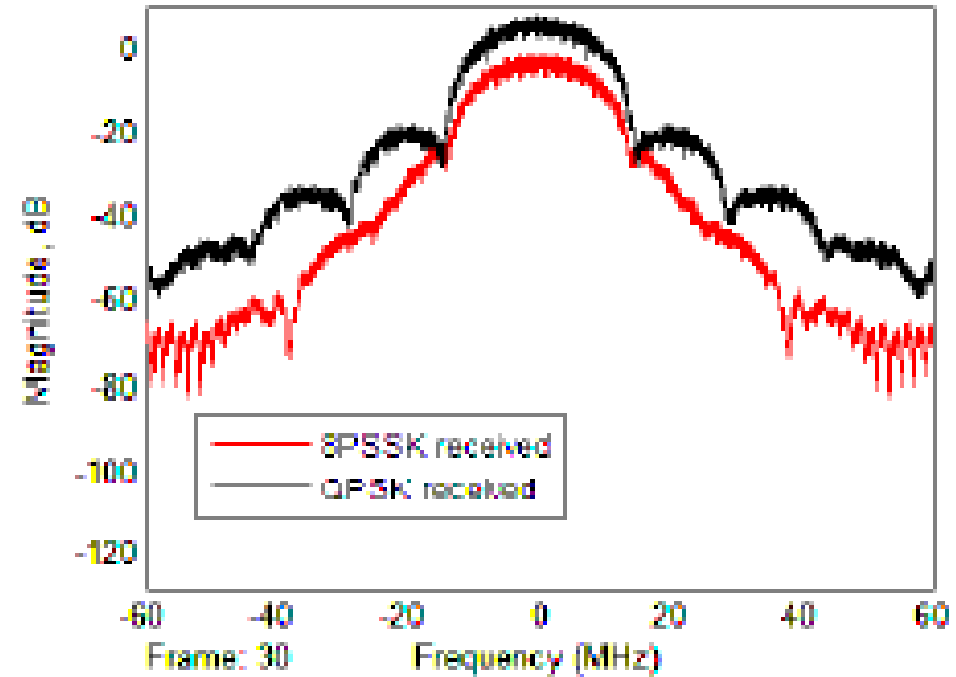
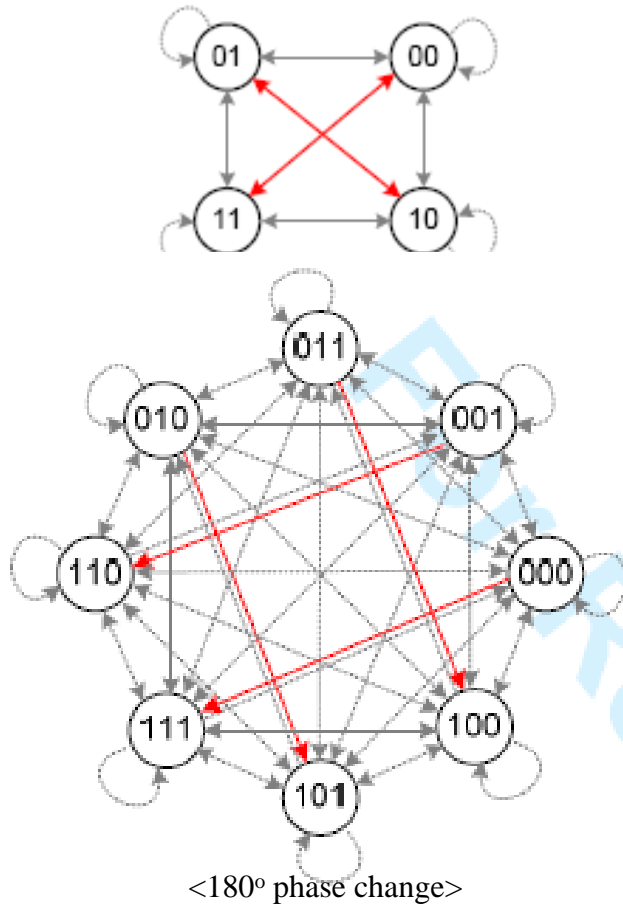

<Spectrum re-growth>

Performance Comparison

- Comparison between 8PSSK and conventional modulations

Modulations	8PSK	QPSK	OQPSK	(G)MSK
Back-off gain ($r=0.3$)	1.5 dB	1.5 dB	0 dB	-1.5 dB
Power gain	3 dB	3 dB	3 dB	3 dB
Bandwidth gain	-3 dB	-1.25 dB	-1.25 dB	0 dB
Performance gain	5.4 dB	1.5 dB	1.5 dB	1.5 dB
Total gain	6.9 dB	4.75 dB	3.25 dB	3 dB

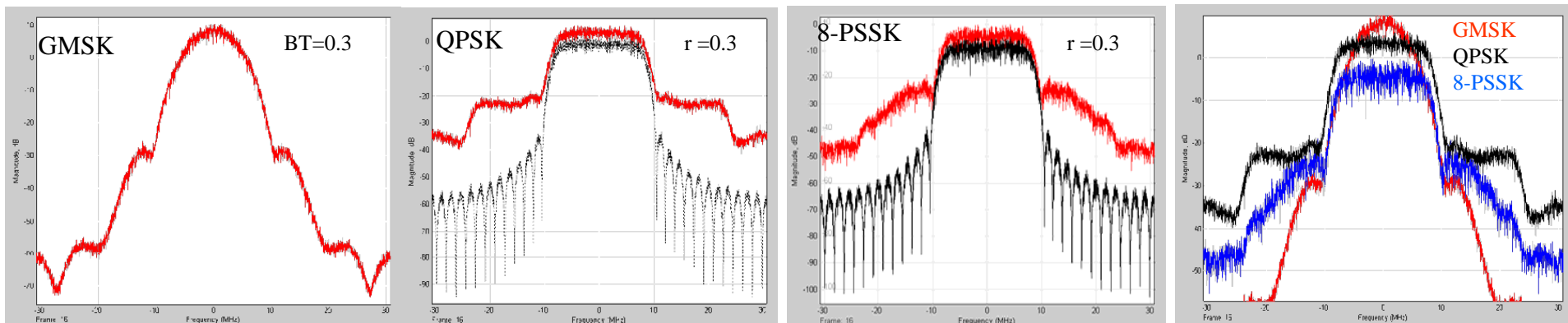

Link Budget (1)

- Receiver sensitivity
 - For 100 kbps
 - $N_0 = -174$ dBm/Hz
 - Required $E_b/N_0 = 10$ dB
 - Noise figure = 10 dB
 - $-174 + 10 + 10 \log(10 \cdot 10^4) + 10 = -104$ dBm
 - For 10 Mbps
 - $-174 + 10 + 10 \log(10 \cdot 10^6) + 10 = -84$ dBm

Link Budget (2)

- Transmit power
 - Adopt maximum transmit power of MICS band
 - Consider the influence to human body
 - Avoid interference to other systems
 - Follow the power limitation of 25 μ W (-16 dBm)

Link Budget (3)

No	Parameters	Unit	8PSSK
1)	Bit rate [R]	Mbps	10
2)	Symbol Period [Tb]	nS	300
3)	In-body Distance [di]	cm	6
4)	Channel Bandwidth [BW]	MHz	13.3
5)	Average TX Power [Pt_avg]	dBm	-16
6)	Pulse-on duration [Tp]	nS	150
7)	Duty Gain [Dg=10*log10(Tb/Tp)]	dB	3
8)	Peak TX Power [Pt = Pt_avg + Dg]	dBm	-13
9)	TX antenna gain [Gt]	dBi	-10
10)	In-body CM2 Path loss [L]	dB	50.5
11)	RX antenna gain [Gr]	dBi	0
12)	RX power [Pr=Pt+Gt+Gr-PLi-PLf]	dBm	-73.5
13)	Receiver AWGN noise floor [N=-174+10log(BW)]	dBm	-102.8
14)	RF noise figure [Nf]	dB	10
15)	Average noise power [Pn=N+Nf]	dBm	-92.8
16)	Minimum EbNo [EN]	dB	10
17)	Minimum SNR [S=EbNo+10log10(R/BW)]	dB	8.8
18)	Implementation loss [I]	dB	3
19)	Link Margin [LM=Pr-Pn-S-I]	dB	7.5
20)	Rx Sensitivity Level [Pmin]	dBm	-82

More information about PSSK

Impact of PAPR on ACP

- PAPR
 - The correlation between PAPR and ACP is not as straightforward as it seems in complicated phase modulation schemes.
 - It is possible for a data stream to have a higher PAPR value while still achieving a better ACP figure.
 - PAPR values are calculated as a difference in dB between peak and average powers
 - Table details the results from the time domain simulations (roll-off factor = 1)
 - The relationship between ACP and PAPR is caused by the variation of the period of pseudo-periodic pulse trains

Modulation scheme	PAPR (dB)
8-PSSK	5.85
QPSK	3.54
8PSK	3.3
Pi/4DQPSK	3.0
OQPSK	3.3

PAPR of PSSK

- Peak-to-average power ratio

$$PAPR = 10 \log_{10} \left(\frac{P_{pk}}{P_{ave}} \right)$$

- P_{ave} of PSSK symbol is smaller than that of the QPSK about 3 dB due to the silence period.
- PAPR of PSSK is greater than QPSK by 3 dB.

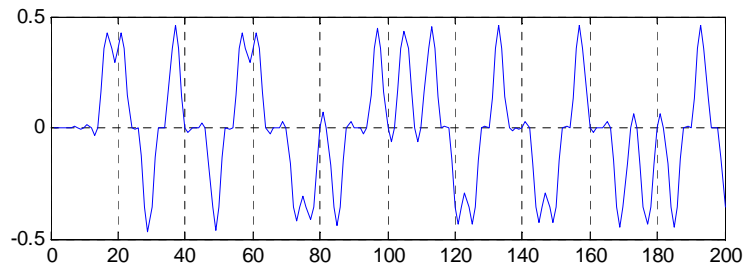
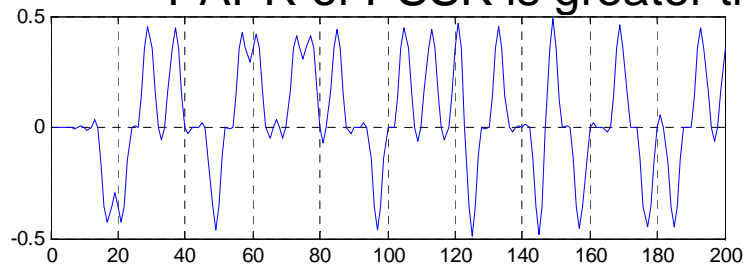

Example of PSSK signal

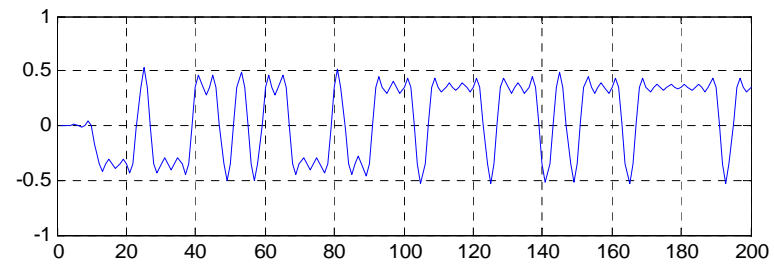
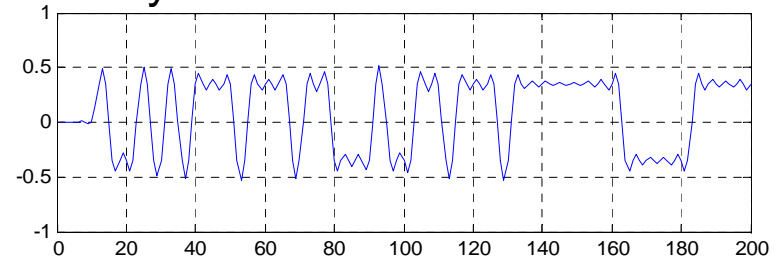

Example of QPSK signal

Nonlinear model

- TWTA (Travelling Wave Tube Amplifier) model
 - Saleh model
 - Saleh, A.A.M., "Frequency-independent and frequency-dependent nonlinear models of TWT amplifiers," IEEE Trans. Communications, vol. COM-29, pp.1715-1720, November 1981.
 - Multiply the signal by a gain factor. Split the complex signal into its magnitude and angle components.
 - Apply an AM/AM conversion to the magnitude of the signal, according to the Saleh model, to produce the magnitude of the output signal.
 - Apply an AM/PM conversion to the phase of the signal, according to the Saleh model, and adds the result to the angle of the signal to produce the angle of the output signal. Combine the new magnitude and angle components into a complex signal and multiply the result by a gain factor, which is controlled by the Linear gain parameter.

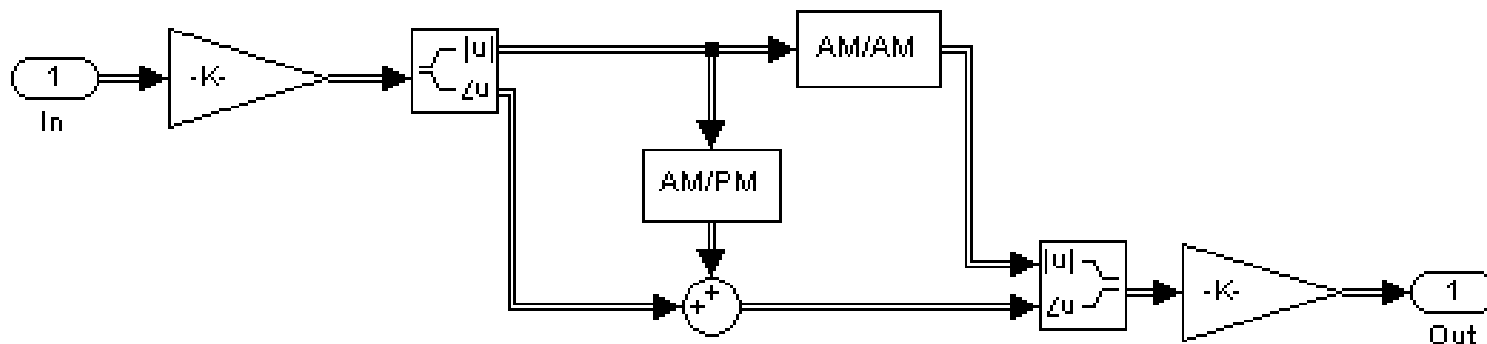

Saleh model

- Saleh method
 - Output voltage against input voltage for AM/AM
 - Output phase against input voltage for AM/PM
 - Amplitude gain for AM/AM

$$F_{AM/AM}(u) = \frac{\alpha \times u}{1 + \beta * u^2}$$

- Phase change for AM/PM

$$F_{AM/PM}(u) = \frac{\alpha \times u^2}{1 + \beta * u^2}$$

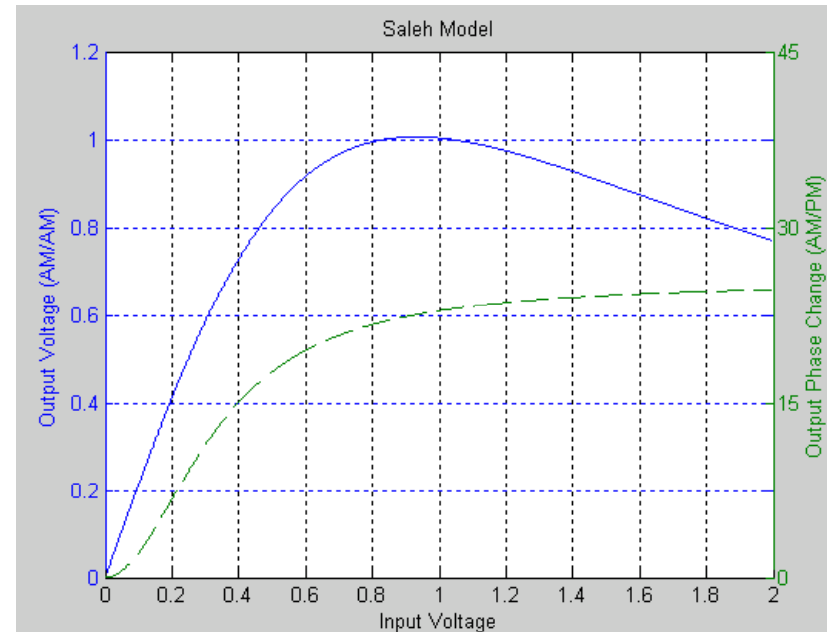

Non-linearity Simulations

- Saleh parameters
 - AM/AM parameters
 - $\alpha = 3$, $\beta = 2$
 - AM/PM parameters
 - $\alpha = 4$, $\beta = 10$

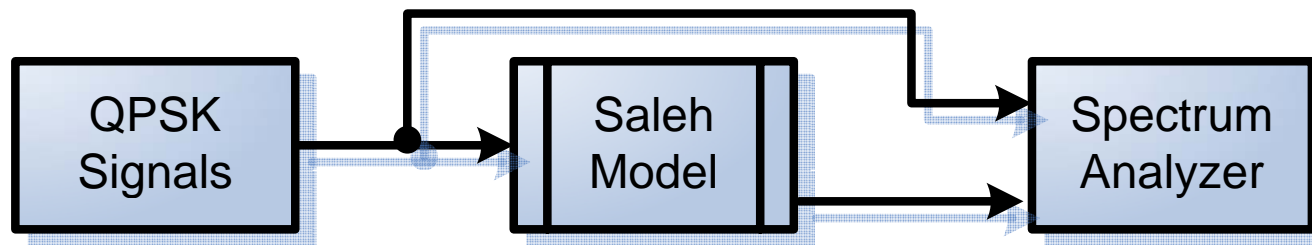
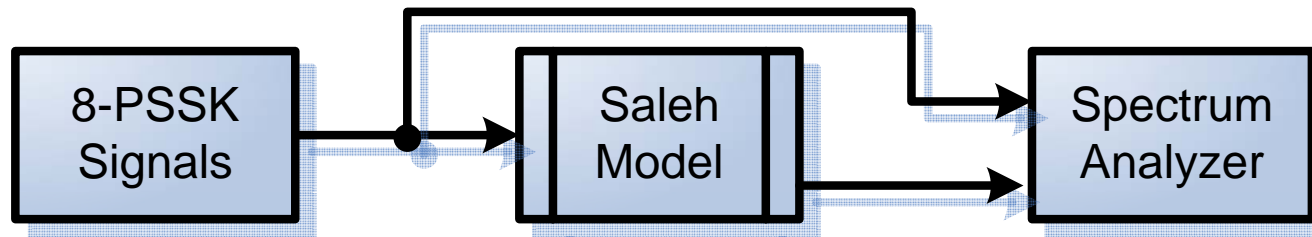

Comparison of QPSK and PSSK spectrums

- ACP comparisons
 - ACP for QPSK case is equal to approximately 17 dB (as follows from the reading of the marker M1), while the PSSK case is approximately 27 dB (reading of the marker M2).
 - This proves that lower PAPR can produce lower (worse) ACP.
- 10 dB difference
 - M1 : -17.5dBm (QPSK)
 - M2 : -27.3 dBm (8PSSK)

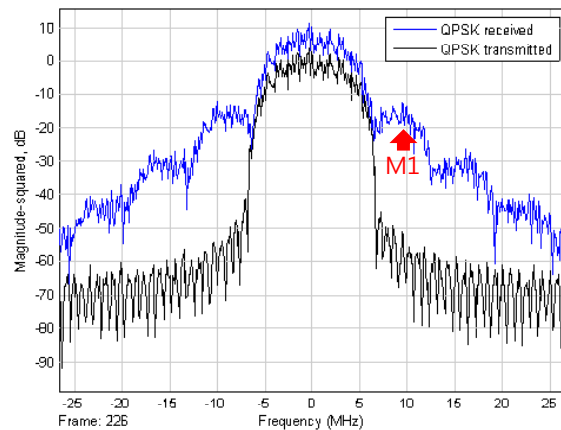

QPSK

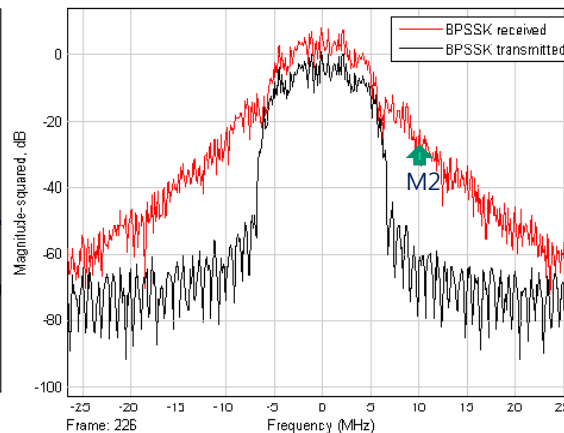

8-PSSK

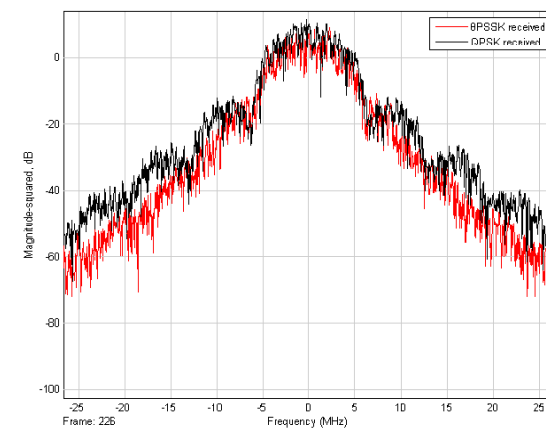

Comparison

Implementation Results

- ACP comparison of baseband analog signals
 - Improvement for 10 dB of Non-linearity Amp. ACP

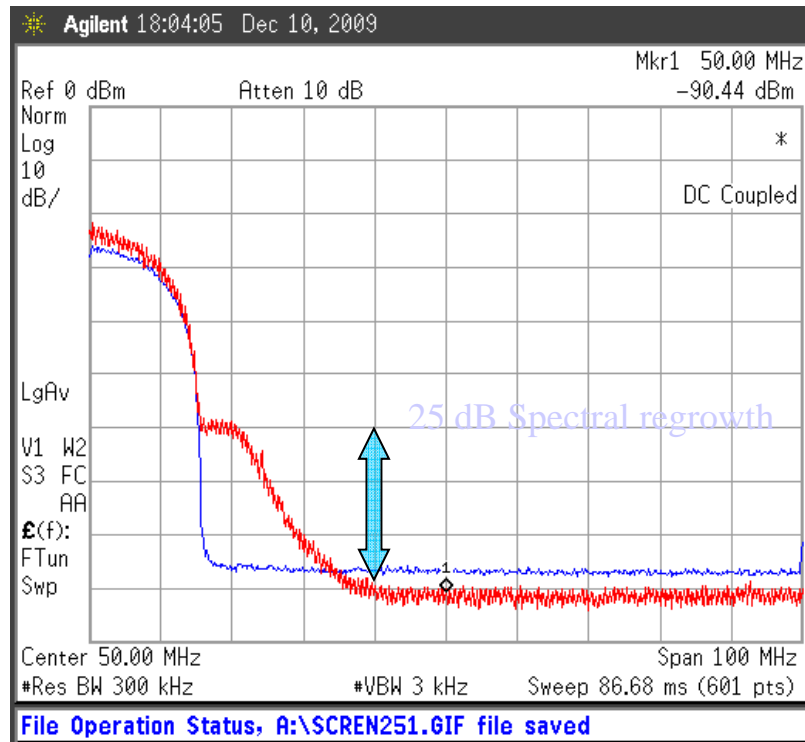

QPSK

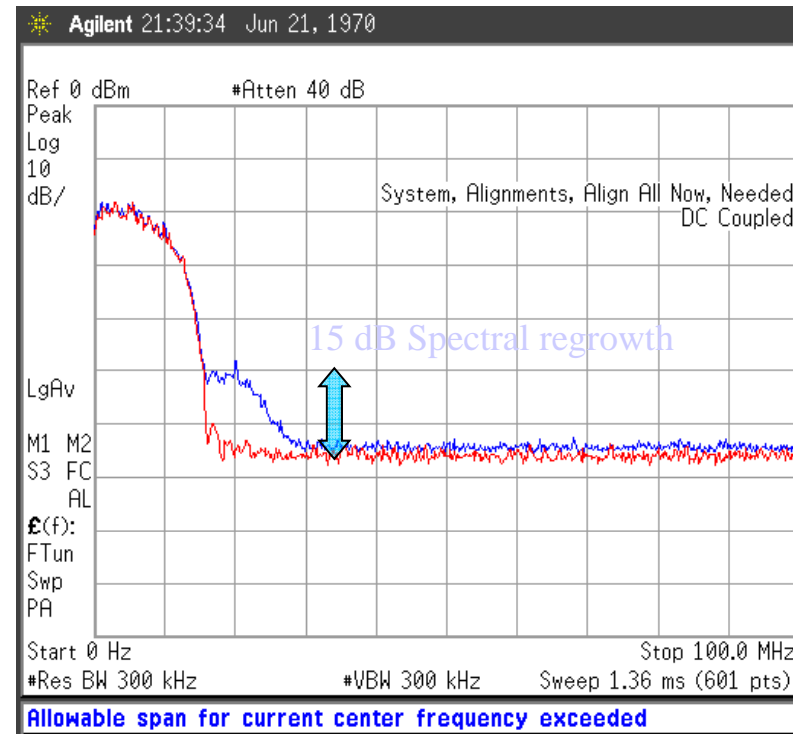

8-PSSK

Regulatory Information

Non-licensed Frequency Bands and Requirements

- General requirement of low-power, non-licensed band for any transmitter

	Frequency (MHz)	Radiated emission limit (uV/m)	Measuring distance (m)	
Korea	~322MHz	500	3	
FCC*	216~960MHz	200	3	Part 15.209
Japan	~322 MHz	500	3	

- Restricted band for USA
 - 240~285, 322~335.4, 399.9~410, 608~614 MHz
- Available frequency band for in-body HDR comm.
 - 285~322 MHz (Korea, Japan, USA)
 - 335.4~399.9, 410~470, 806~902 MHz (USA)

Band for USA

- Understanding the FCC Regulations for Low-Power, Non-licensed Transmitters
 - Available at
http://www.fcc.gov/Bureaus/Engineering_Technology/Documents/bulletins/oet63/oet63rev.pdf

Frequency Band	Type of Use	Emission Limit	Det	47 CFR
285-322 MHz	Intermittent Control Signals	$(125/3) \times f(\text{MHz}) - (21250/3) \mu\text{V/m @ 3 m}$	A or Q	15.231
285-322 MHz (cont.)	Periodic Transmissions	$(50/3) \times f(\text{MHz}) - (8500/3) \mu\text{V/m @ 3 m}$	A or Q	15.231
	Any	$200 \mu\text{V/m @ 3 m}$	Q	15.209

Band for Japan

- Regulation of the Extremely Low Power Radio Station

– Available at

<http://www.tele.soumu.go.jp/e/ref/material/rule/index.htm>

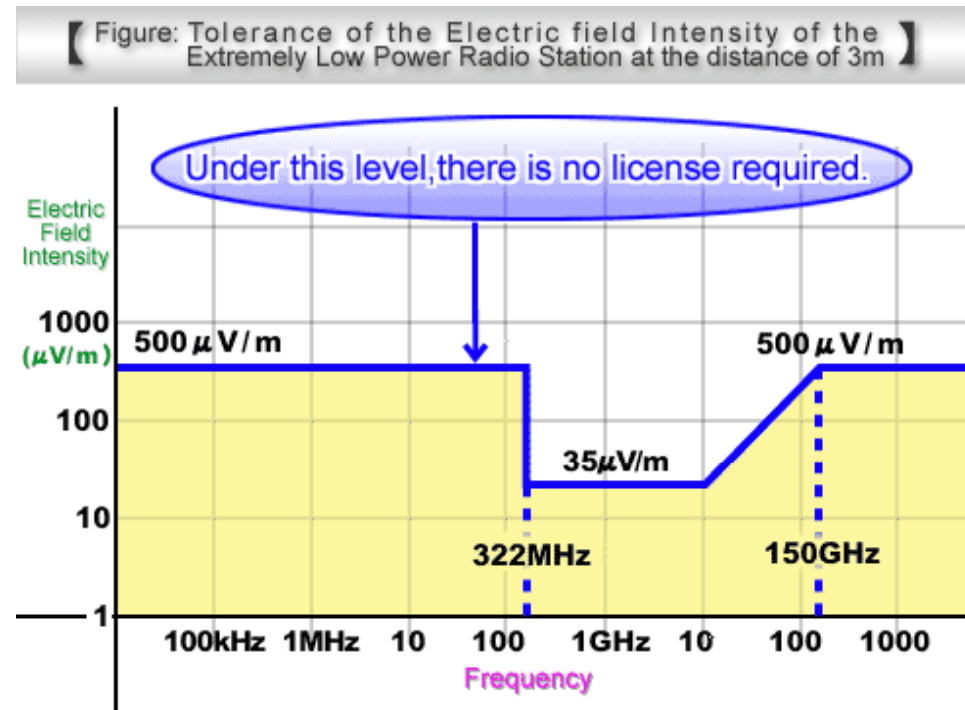

How can we satisfy the regulation?

Experiment Environment

- Test fixture for implant devices (FCC Rule 95.639(f))
 - Available at http://edocket.access.gpo.gov/cfr_2008/octqtr/pdf/47cfr95.639.pdf
 - Consider environment of a human body
 - Use to simulate operation of the implant under actual operating conditions

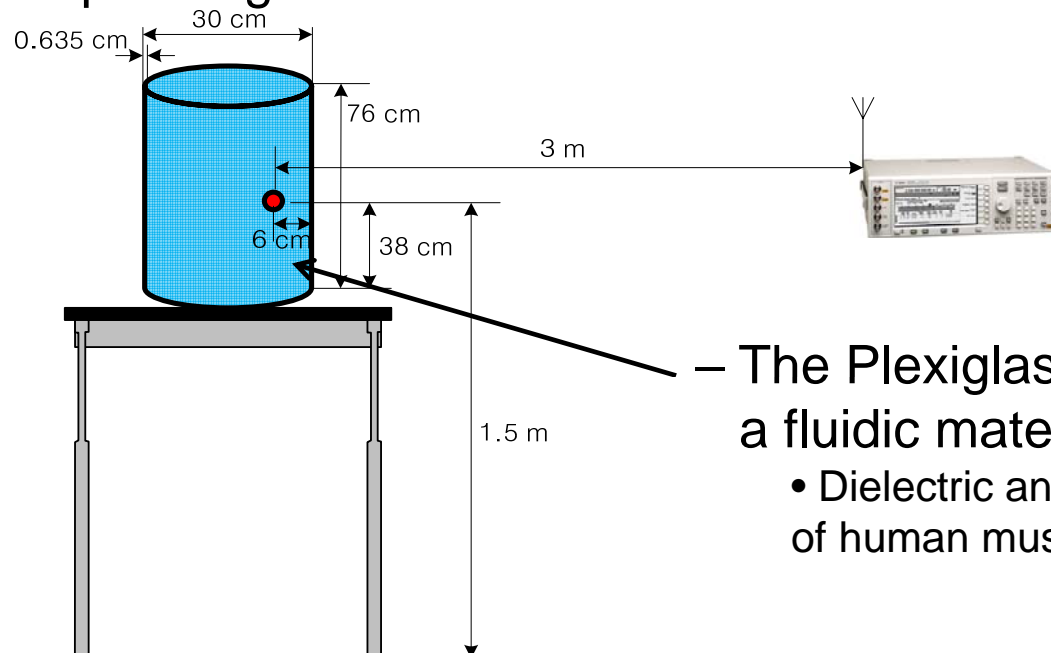

- The Plexiglas filled with a fluidic material
 - Dielectric and conductivity properties of human muscle tissue

Emission Limit

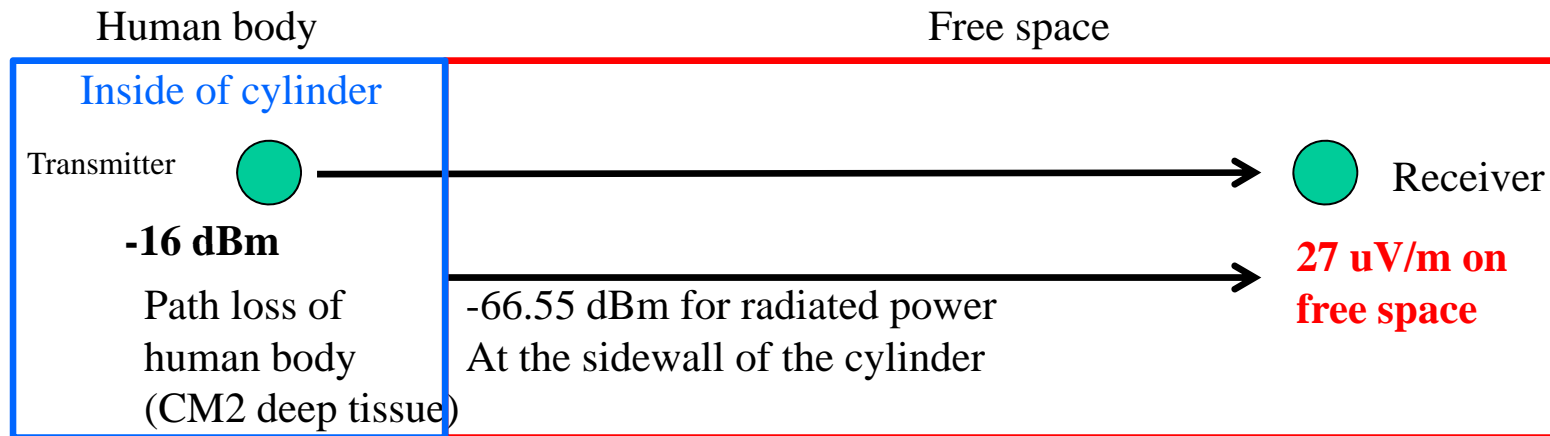

- Transmit power of implant device: -16 dBm
- Radiated power at the sidewall of the cylinder: -66.55 dBm
 - Path loss of human body (CM2 deep tissue): -50.55 dBm (6cm)
 - Radiated power on the skin
- The limitation of measured emission power at 3 m distance : **27 uV/m (< 200 uV/m)**
- In-body antenna will also show the huge attenuation in the free space because of dielectric constant and conductivity of human body

Conclusions

- Phase silence shift keying
 - Combination of PPM and PSK
 - Transmit power efficient for 3 dB due to silence duration
 - Performance enhancement from enlarged minimum distance
 - Back-off gain for usage of non-linear device

- Frequency band allocation for in-body high data rate (HDR)
 - Low power, non-licensed band for any transmitter

- Method for satisfaction of the regulation
 - Use test fixture of implant transmitter (FCC Rule 95.639(f))
 - Emission power at 3 m is under 200 μ W

How can we satisfy the regulation?

Non-licensed Frequency Bands and Requirements

- General requirement of low-power, non-licensed band for any transmitter

	Frequency (MHz)	Radiated emission limit (uV/m)	Measuring distance (m)	
Korea	~322MHz	500	3	
FCC*	216~960MHz	200	3	Part 15.209
Japan	~322 MHz	500	3	

- Restricted band for USA
 - 240~285, 322~335.4, 399.9~410, 608~614 MHz
- Available frequency band for in-body HDR comm.
 - 285~322 MHz (Korea, Japan, USA)
 - 335.4~399.9, 410~470, 806~902 MHz (USA)

Experiment Environment

- Test fixture for implant devices (FCC Rule 95.639(f))
 - Consider environment of a human body
 - Use to simulate operation of the implant under actual operating conditions

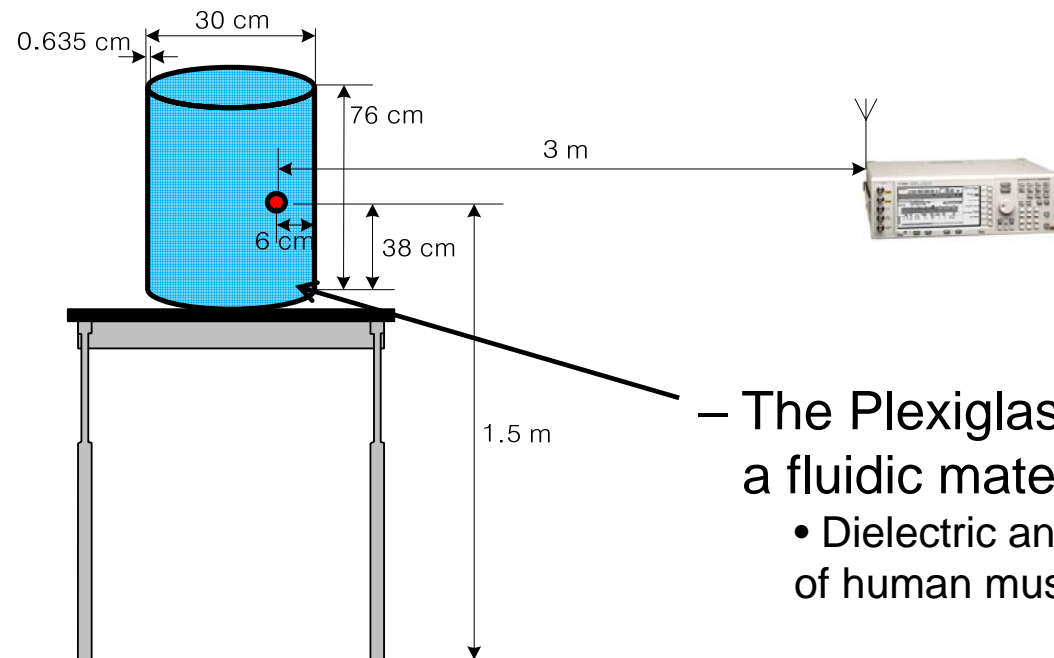

- The Plexiglas filled with a fluidic material
 - Dielectric and conductivity properties of human muscle tissue

Emission Limit

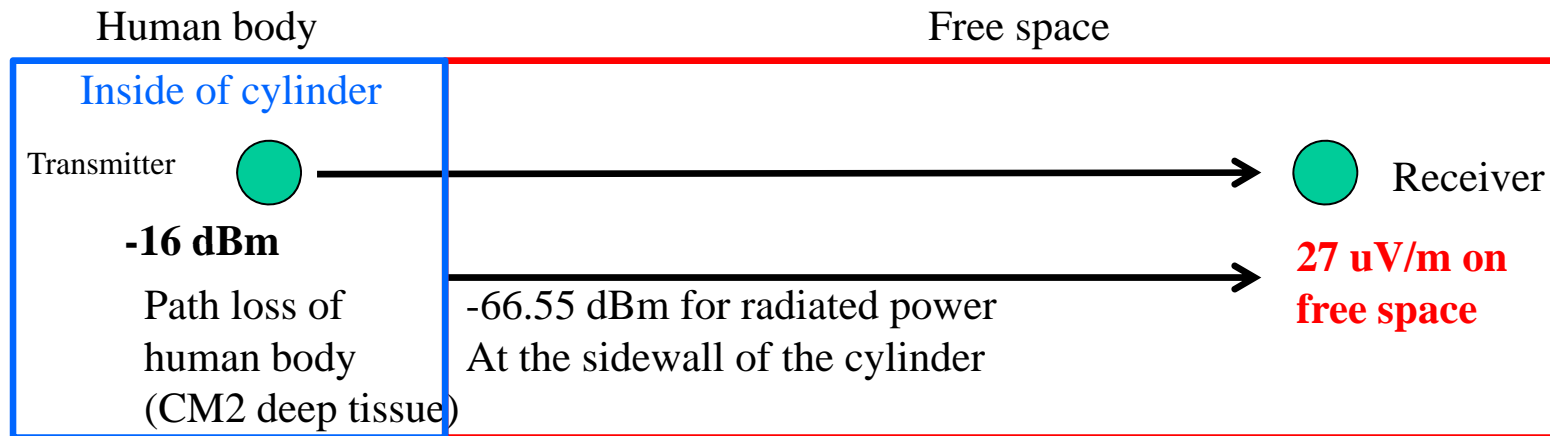

- Transmit power of implant device: -16 dBm
- Radiated power at the sidewall of the cylinder: -66.55 dBm
 - Path loss of human body (CM2 deep tissue): -50.55 dBm (6cm)
 - Radiated power on the skin
- The limitation of measured emission power at 3 m distance : **27 uV/m (< 200 uV/m)**
- In-body antenna will also show the huge attenuation in the free space because of dielectric constant and conductivity of human body

Conclusions

- Phase silence shift keying
 - Combination of PPM and PSK
 - Transmit power efficient for 3 dB due to silence duration
 - Performance enhancement from enlarged minimum distance
 - Back-off gain for usage of non-linear device
- Frequency band allocation for in-body high data rate (HDR)
 - Low power, non-licensed band for any transmitter
- Method for satisfaction of the regulation
 - Use test fixture of implant transmitter (FCC Rule 95.639(f))
 - Emission power at 3 m is under 200 uW
- More information will be provided by Feb. 15.