

Project: IEEE P802.15 Working Group for Wireless Personal Area Networks (WPANs)

Submission Title: [Link Recovery for VLC]

Date Submitted: [22 October, 2009]

Source: [Ying Li, Sridhar Rajagopal] Company [Samsung Electronics]

Address [1301 E. Lookout Drive, Richardson, TX 75082, USA]

Voice:[1-972-761-7903], FAX: [1-972-761-7909], E-Mail:[yli2@sta.samsung.com]

Re: []

Abstract: [A fast and energy-efficient link recovery mechanism for VLC is proposed.]

Purpose: [Contribution to IEEE 802.15.7 VLC TG]

Notice: This document has been prepared to assist the IEEE P802.15. It is offered as a basis for discussion and is not binding on the contributing individual(s) or organization(s). The material in this document is subject to change in form and content after further study. The contributor(s) reserve(s) the right to add, amend or withdraw material contained herein.

Release: The contributor acknowledges and accepts that this contribution becomes the property of IEEE and may be made publicly available by P802.15.

Link Recovery for VLC

Samsung Electronics

Motivation

- Need for fast link recovery
 - In the VLC system, LOS (Line of Sight) communication between two VLC transceivers constitutes the majority of the applications. However, the temporal blocking, can cause burst frame errors, or even link failure.
 - The poor pointing of the VLC devices may cause the decrease of signal quality or even link disconnection.
 - The interference from other devices may cause burst frame errors, or even link failure.
- Opportunity for mobile device battery saving
 - In WLAN, usually infrastructure does not have concern on power supply, however, the mobile usually has a battery life concern.
 - Usually the blocking may block both UL and DL.
 - UL link recovery can be done via DL link recovery, to save mobile's battery.

Link recovery in VLAN, mobile side

- In VLAN
 - MN self-decides when to stop sending data
 - If there is only UL data service, MN sends fast link recovery signal to AP
 - If there is also DL data service, MN waits.

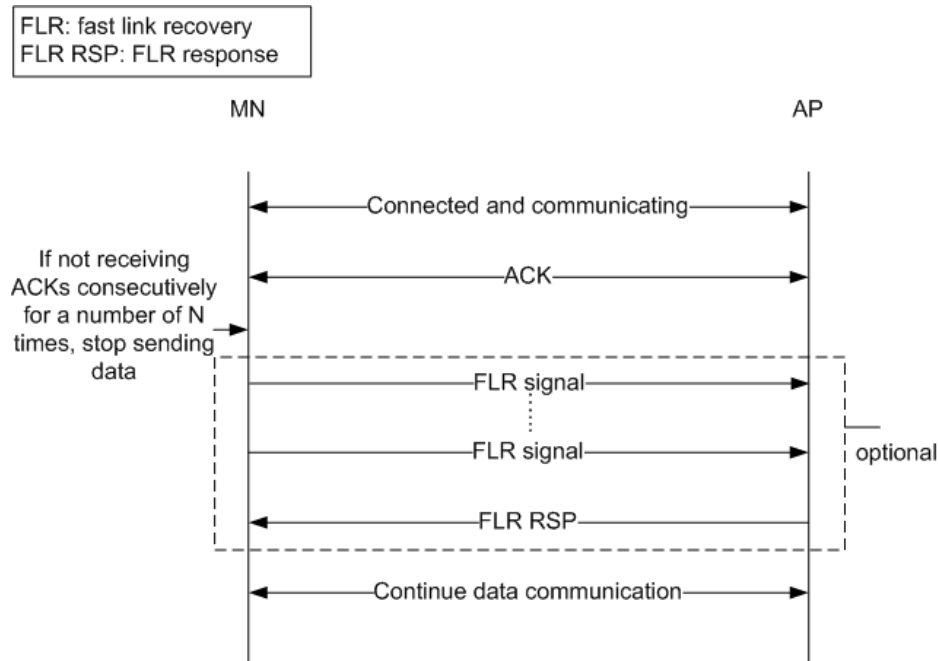

Link recovery in VLAN, infrastructure side

- In VLAN
 - AP self-decides when to stop sending data
 - AP sends fast link recovery signal to MN, for either case of DL service only, or case of DL and UL service.

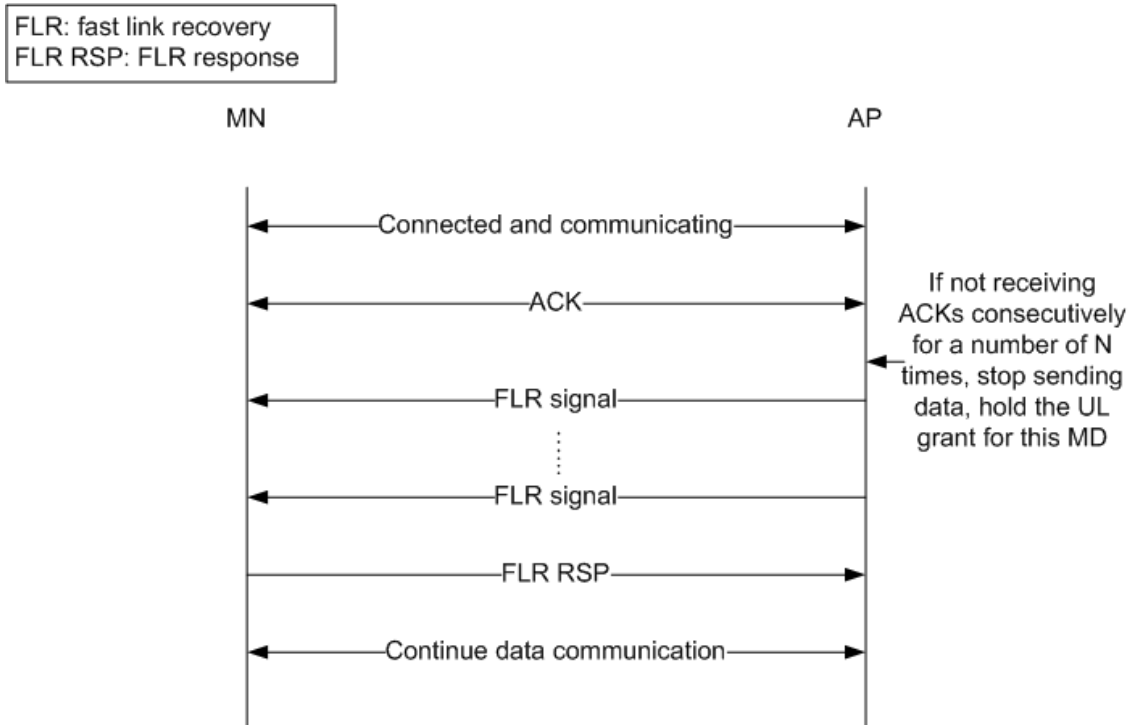

Link recovery in peer-to-peer case

- In peer-to-peer case
 - The link recovery for VLAN can be extended to peer-to-peer communication.
 - In addition, the battery life can be a parameter to decide who sends FLR signal

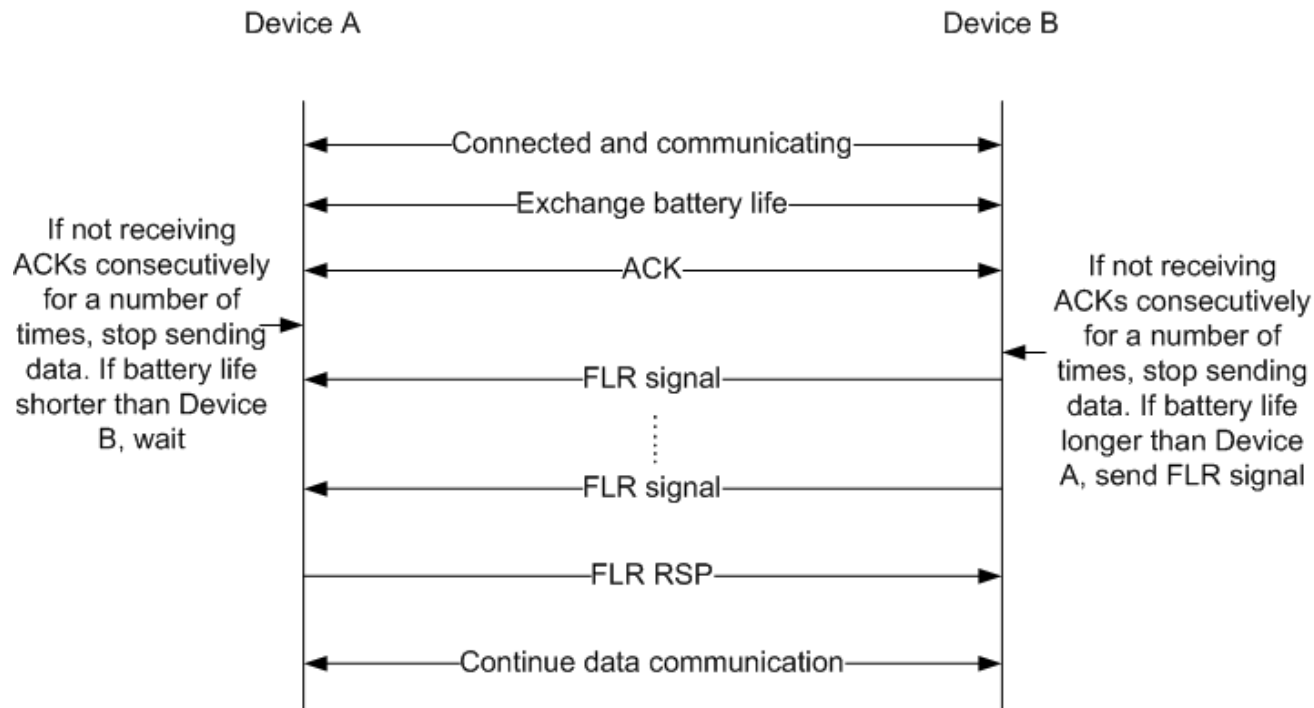

Link recovery for multiple LEDs

- For a device with multiple LEDs of different angles
 - Once fast link recovery is triggered at one angle, the device uses other angles to send FLR signals to test links.
- Note: This can be done at the receiver end as well

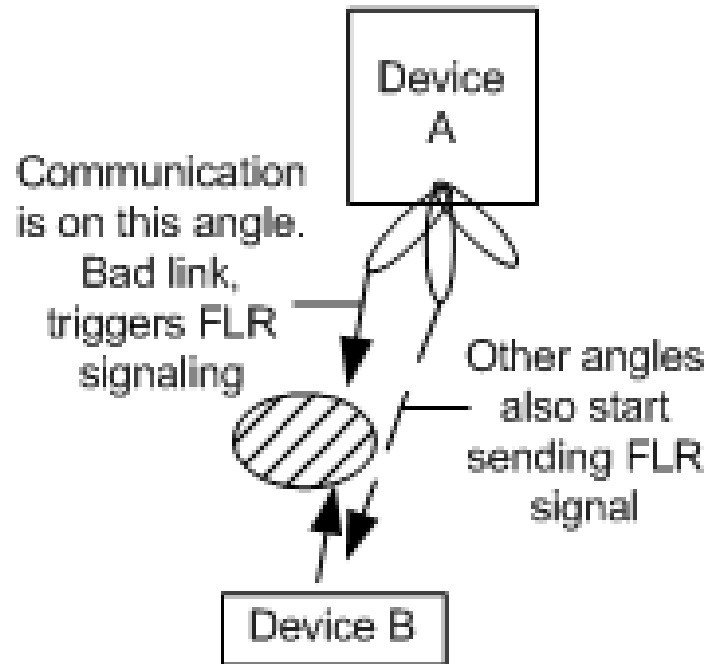

Link recovery for multiple color bands

- For a device with multiple color bands
 - Once fast link recovery is triggered at one color band, the device uses other color bands to send FLR signals to test links.

