

Project: IEEE P802.15 Working Group for Wireless Personal Area Networks (WPANs)

Submission Title: [ETRI PHY Proposal on VLC TDM for LED Signboard]

Date Submitted: [23 September, 2009]

Source: [Dae Ho Kim, Tae-Gyu Kang, Sang-Kyu Lim, Ill Soon Jang, Dong Won Han] Company [ETRI]

Address [138 Gajeongno, Yuseong-gu, Daejeon, 305-700]

Voice:[+82-42-860-5648], FAX: [+82-42-860-5218], E-Mail:[dhkim7256@etri.re.kr]

Re: [Response to call for proposals]

Abstract: [This document describes a proposal of PHY TDM for LED signboard]

Purpose: [Proposal to IEEE 802.15.7 VLC TG]

Notice: This document has been prepared to assist the IEEE P802.15. It is offered as a basis for discussion and is not binding on the contributing individual(s) or organization(s). The material in this document is subject to change in form and content after further study. The contributor(s) reserve(s) the right to add, amend or withdraw material contained herein.

Release: The contributor acknowledges and accepts that this contribution becomes the property of IEEE and may be made publicly available by P802.15.

ETRI Proposal on VLC TDM for LED Signboard

Dae Ho Kim

dhkim7256@etri.re.kr

ETRI

Contents

- ETRI PHY Considerations and Scope
- Summary of ETRI PHY Proposal
- Architecture and operation of Signboard
- Proposed Multiplexing Technology
 - TDM
- Summary

ETRI PHY Considerations based on TCD

- Target Application
 - VLC using the Illumination at office/home environment
 - White LED & RGB LED
- Considered data rate and range: A1*
 - Infrastructure to mobile
 - High data rate: 1Mbps~
 - Short range: $\leq 3\text{m}$
- Divergence angle of illumination
 - Very various
 - LED fluorescent: $110^\circ \sim 310^\circ$
 - PAR type: $60^\circ \sim 140^\circ$ ($30^\circ \sim 40^\circ$ is possible)

ETRI PHY Scope

- Office illumination
 - Infrastructure to mobile
- Transmission device
 - white LED (yellow phosphor)
 - R, G, B LED
- Data rate and distance
 - 1Mbps(DL/UL) @2.5m
- Directivity
 - Bi-directional (Full or Half), Uni-directional

ETRI PHY Proposal

- Line code
 - 4B6B
 - Modified-4B5B: M-4B5B
- Modulation
 - Variable Pulse Position Modulation: VPM
 - Reverse-Return to Zero: R-RZ
- Multiplexing
 - Time Division Multiplexing(TDM) for LED signboard

Architecture of general LED signboard

- Line scan : selection of line for data stream, sequentially repeat
 - Active high
 - Determine the operating time of each line
- Data : on/off or color selection information of each dot on the selected line
 - Active low

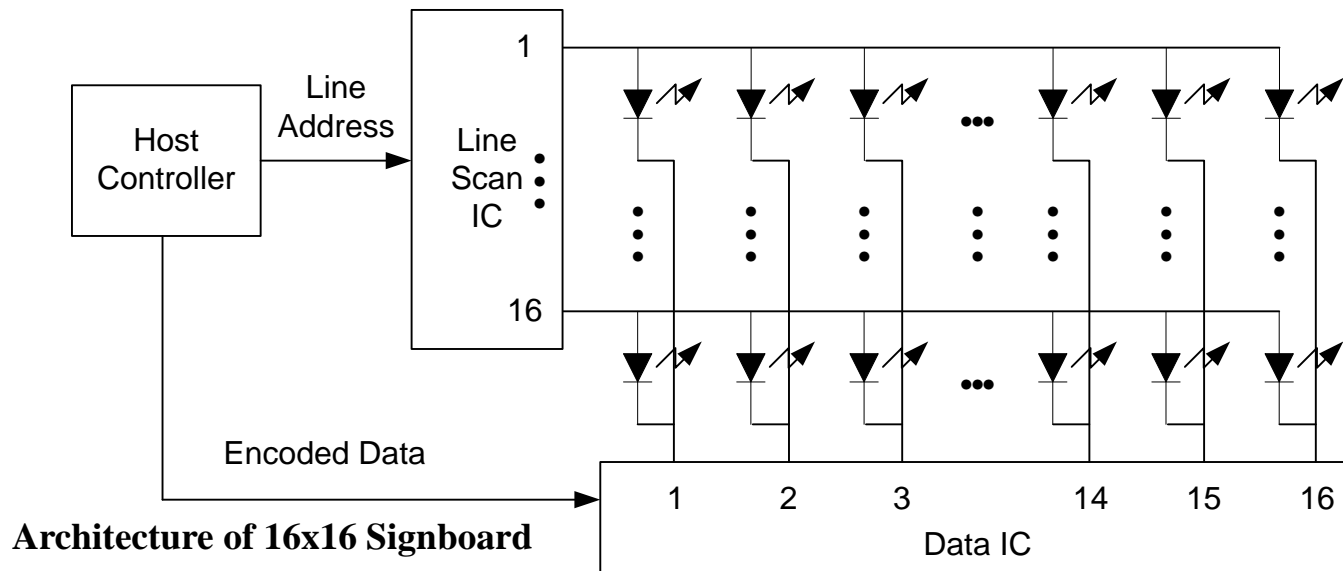

Operation of 16x16 Signboard

- PC Monitor, TV: transmit 60 frames/sec
 - Transmit 30 frames twice
- At 16X16 signboard, 16 Lines have to operate 60 times during 1 second.
 - Operating time for 1 line : $(1\text{s}/60\text{f})/16\text{fpl} \approx 1\text{ms}/16$
 - At the signboard industry, generally 25 to 60 fps is used

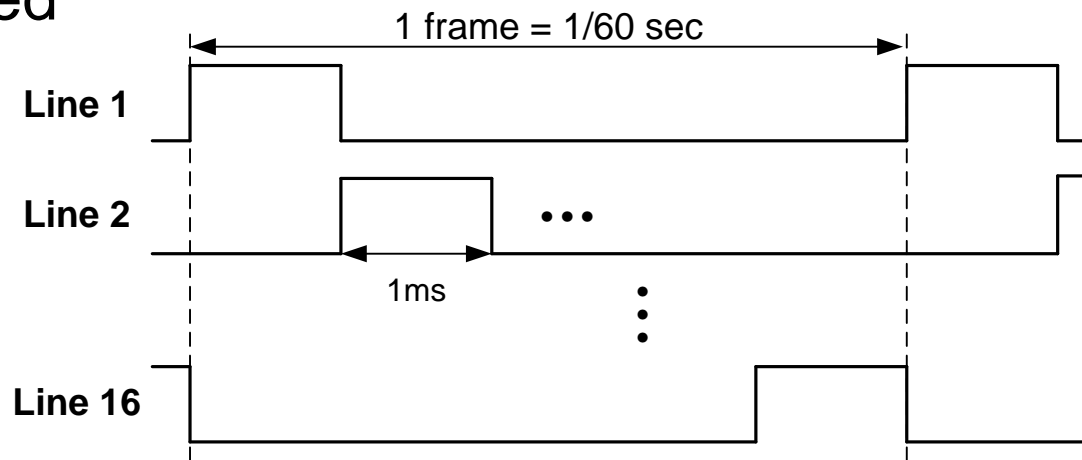

TDM for Signboard

- Line operating time = 1ms \rightarrow 1 time slot
 - 16 time slots is possible
- 1Mbps: 1kbits/1ms = 125bytes/1slot

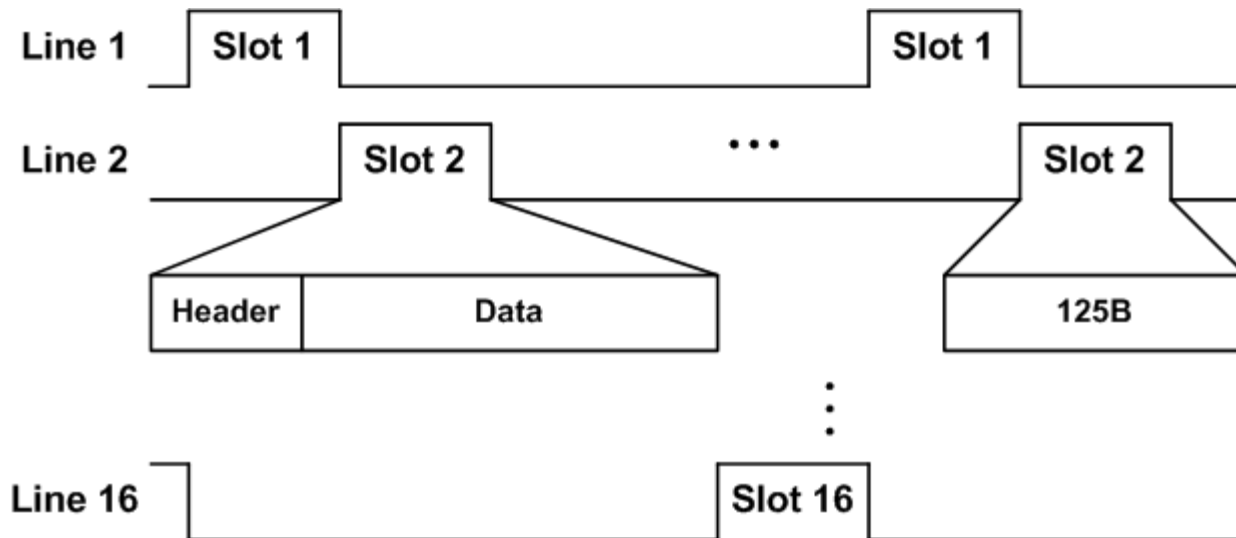

Requirements for VLC at signboard

- Required same brightness at each time slot
 - Required flickering free technology, such as 4B6B line code and Manchester code
- Required same brightness whenever data is transmitted or not.
 - Idle slot modulation
- Required same brightness before VLC is applied
 - Brightness will be reduced to 50% by VLC data stream
 - Need to increase of operating time per line
 - 100% duty of 1ms = 50% duty of 2ms = 1ms on time per second
- Using simple frame structure, increase the link efficiency

Proposed TDM for Signboard: solution 1

- Increase Line operating time = 2ms/1 time slot
- Reduce time slot
 - 8 time slots
 - Divide to two block of 8x16
- 1Mbps: $2\text{kbits}/2\text{ms} = 250\text{bytes}/1\text{slot}$

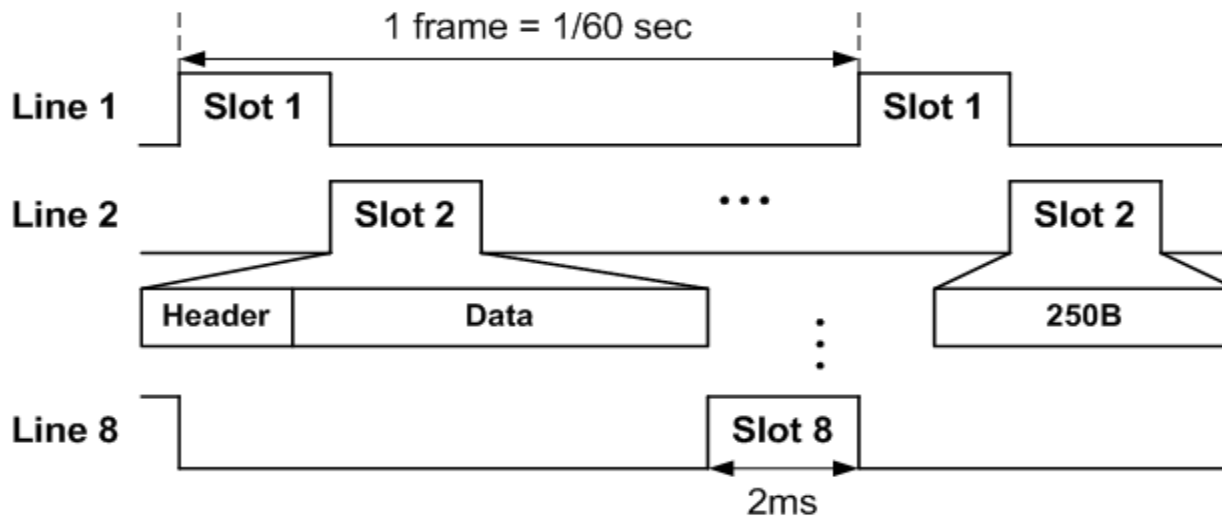

Proposed TDM for Signboard: solution 2

- Increase Line operating time = 2ms/1 time slot
- Increase period
 - 16 time slots
 - 30 frames per second
- 1Mbps: $2\text{kbits}/2\text{ms} = 250\text{bytes}/1\text{slot}$

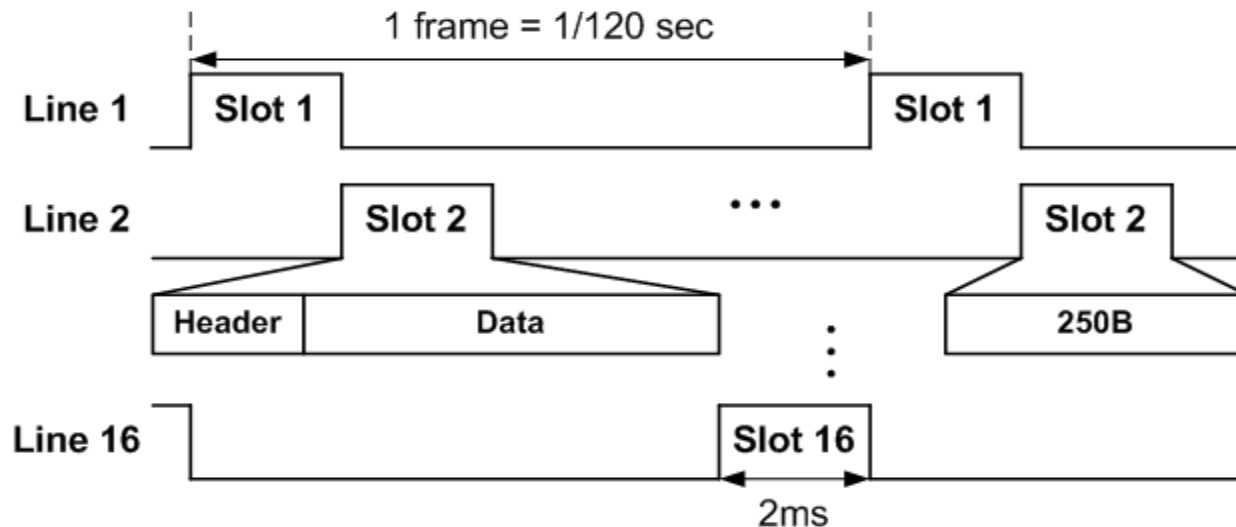

Purpose of Beacon slot

- General purpose of beacon frame
- Is to Inform that the following frame is a TDM time slot
 - Number of time slot
 - Length of time slot
- is to allocate the time slot according to
 - Service
 - User
 - QoS policy by multiple slot allocation according to service level

Time slot structure

- Beacon slot
 - TS0
 - VLC header for compatibility
 - Source address and destination address
 - Length field of beacon slot
 - Service type
 - Information Broadcast service
 - Data download service
 - Time slot information
- Data slot
 - TS1 to end of TS
 - Simple header
 - Destination address (only for data download service)
 - No length field

Expected Applications

- Multiple broadcast service at Food court, department, and so on
 - TS1 (Korean), TS2(Japanese), ... , TS16(information)
 - TS1 (1'st floor), TS2(2'nd floor), ...
- QoS supported membership service
 - Different data download speed by membership level
 - Gold member allocate 3 time slot
 - Silver member allocates 2 time slot
 - Bronze member allocates 1 time slot

Summary of Proposal

- Operating time of each line(LED) on the signboard is fixed
 - Propose TDM
- Propose time slot structure and allocation
- Propose multiple broadcast service and QoS service
- If we use VPM for LED signboard, we can control brightness of signboard.