

Project: IEEE P802.15 Working Group for Wireless Personal Area Networks (WPANs)

Submission Title: 15.7 System PHY Proposal for VLC Applications

Date Submitted: September 23, 2009

Source: Soo-Young Chang, CSUS, Myunghee Son, Kyeong Tae Kim, Jong-Hyun Park, and Sung Won Sohn, ETRI

E-Mail: sychang@ecs.csus.edu, mhson@etri.re.kr

Re: Some technical system design details for 15.7 VLC

Abstract: Some technical details for VLC PHY systems are being proposed.

Purpose: To Introduce some technical issues on visible light communications

Notice: This document has been prepared to assist the IEEE P802.15. It is offered as a basis for discussion and is not binding on the contributing individual(s) or organization(s). The material in this document is subject to change in form and content after further study. The contributor(s) reserve(s) the right to add, amend or withdraw material contained herein.

Release: The contributor acknowledges and accepts that this contribution becomes the property of IEEE and may be made publicly available by P802.15.

***15.7 SYSTEM PHY PROPOSAL
FOR VLC APPLICATIONS
- WITH EMPHISIS ON VEHICULAR APPLICATIONS -***

Soo-Young Chang, CSUS,
and

Myunghee Son, Kyeong Tae Kim, Jong-Hyun Park,
and Sung Won Sohn, ETRI

Sep. 2009

Table of Contents

- Overview of 15.7 systems
- Frame structures and architectures
- Modulation
- Duplex/multiplex/multiple access
- Multi-hop VLC for extended ranges

OVERVIEW OF 15.7 SYSTEMS

IEEE 802.15.7

- Broad range of Data rates:
from 50 Kbps to 100 Mbps
- Operates in visible light bands:
380 ns ~ 780 ns wavelengths:
no constraint for band division

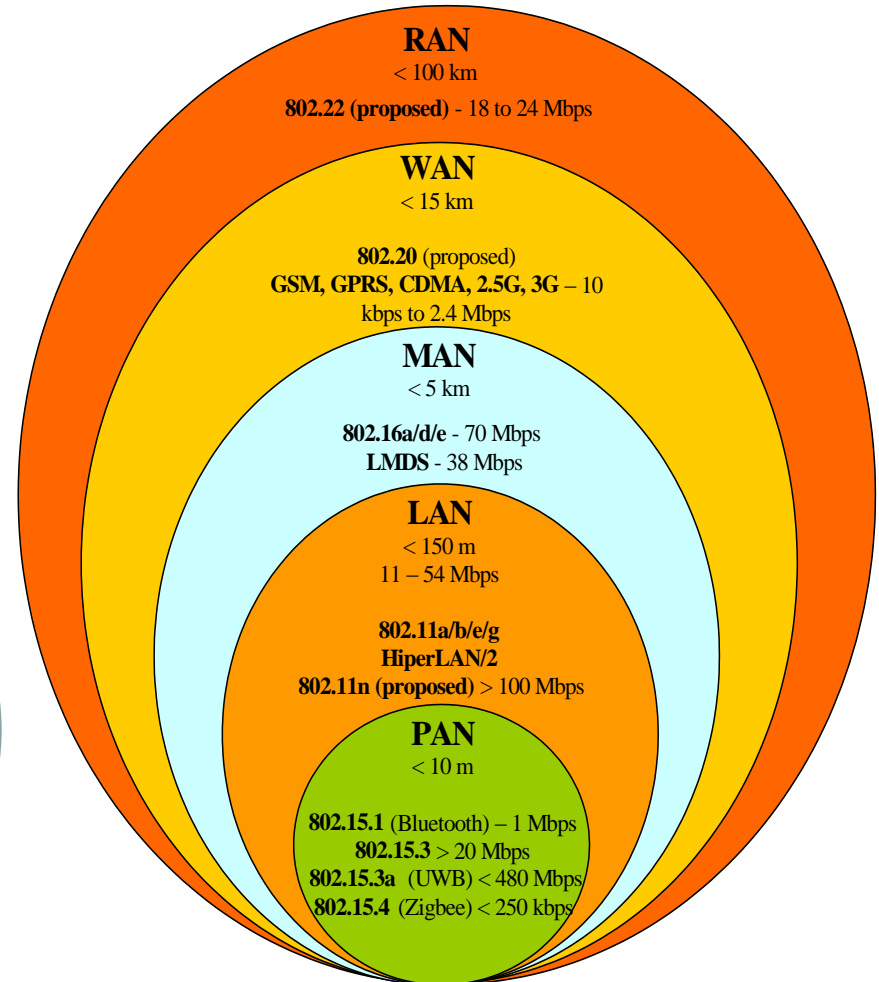
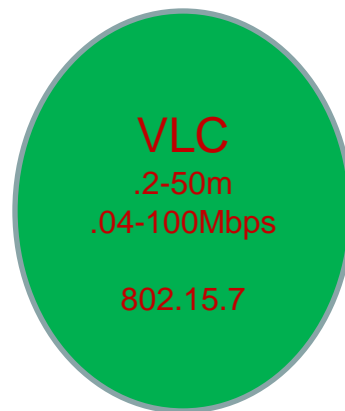

DEFINITION OF APPLICATIONS - NONVEHICULAR

- Mobile/fixed – mobile (short range)
 - Exchange information between mobile/fixed units
- Infra – mobile/fixed (indoor, low speed)
 - Simple information broadcasted from infra
 - Simple information delivered to infra
- Infra – mobile/fixed (indoor, high speed)
 - Information broadcasted from infra (WLAN access point)
 - Information delivered to infra (WLAN user)
- Infra – mobile/fixed (outdoor)
 - Information broadcasted from infra
 - Simple information delivered to infra

DEFINITION OF APPLICATIONS - VEHICULAR

- Traffic lights (or infra) – vehicle
 - Signal and/or traffic information delivered to vehicle
 - Vehicle and/or road information delivered to traffic lights (or infra)
- Vehicle – vehicle
 - Traffic information exchange
 - Maneuvering information exchange in a group
 - Relay traffic information from front vehicle to rear vehicle

ISSUES FOR VEHICULAR APPLICATIONS (1)

- Link set-up time <30 ms: **need to be simple for link set-up**
 - In a multinode environment and, especially in a free space situation with unpredictable and fast changing link conditions.
 - To establish a new communication link, exchanges data on this link, and closes the link within only one frame.
 - To provide a very fast link re-establishment within one frame after short break-outs.
- Beam forming and zone sectoring
 - Appropriate beam forming and/or zone sectoring may be needed to share communication resources and to exchange information with right communication partners by directing in right directions with appropriate beam widths.
 - Focusing
 - Beam shaping
 - Multi beam antennas
 - Defining communication zones
 - Supporting multiple links at the same time

ISSUES FOR VEHICULAR APPLICATIONS (2)

- Few milliseconds latencies and communication delays.
- Need of distance estimation of the communicating party
- Interference mitigation provided
- Adaptive data speed with minimum speed of 100 Kbps
 - The data transmission speed is negotiated at the set-up of the link and can be changed during the communication session.
 - Adaptive modulation schemes adaptive to data rates
- Handover needed
 - A Handover is possible in the same medium (VL to VL) as well as between different media (e.g. VL to IR or Microwave) to guarantee the continuity of the communication session.

ISSUES FOR VEHICULAR APPLICATIONS (3)

- Multiple types of communications
 - Point-to-Point
 - Point-to-Multipoint
 - Multiple Point-to-Multipoint
 - Broadcast
 - Multicast
 - Anycast
 - Master-Slave
- Master-slave setting for Multiple Access (MA) management
- New node registration to the network
- Collision problem solving

OPERATION SCENARIOS

TRAFFIC LIGHT – VEHICLE

- Type of devices
 - Two-way communicator (traffic light) and reactor (vehicle)
 - Master and slave or primary and secondary
 - Traffic light: master or primary
 - Vehicle: slave or secondary
- Operating mode
 - Active communication mode: **two-way communications**
 - Passive communication mode: **one-way broadcasting**
- Network initiation: **just addressing is enough.**
- Type of information delivered
 - Traffic light → vehicle: signal information, traffic information, etc.
 - Vehicle → traffic light: road state information collected including accident information

OPERATION SCENARIOS

INFRA – VEHICLE

- Type of devices
 - Two-way communicator (road side unit) and reactor (vehicle)
 - Master and slave or primary and secondary
 - Road side unit : master or primary
 - Vehicle: slave or secondary
- Operating mode:
 - Active communication mode: **two-way communications**
 - Passive communication mode: **one-way broadcasting**
- Network initiation: **just addressing is enough.**
- Type of information delivered
 - Road side unit → vehicle: local information, traffic information, etc.
 - Vehicle → road side unit: road state information collected including accident information

OPERATION SCENARIOS

VEHICLE – VEHICLE

- Type of devices
 - Two-way communicator and reactor
 - Master or slave or primary or secondary
- Operating mode
 - Active communication mode: **two-way communications**
 - Passive communication mode: **one-way broadcasting**
- Network initiation: **needs networking, but just addressing will be enough.**
- Type of information delivered
 - Vehicle → vehicle relay: local information, traffic or traffic light information
 - Vehicle → vehicle: road state information collected including accident information
 - Vehicle → vehicle in a group: maneuvering information exchange in a group

OPERATION SCENARIOS

MOBILE – MOBILE (1)

- Type of devices
 - Two-way communicator and reactor
 - Master or slave or primary or secondary
- Operating mode: 20 cm max: near field communication (NFC)
 - Active communication mode: **two-way communications**
 - Passive communication mode : **one-way broadcasting**
- Type of information delivered
 - Mobile \leftrightarrow mobile: data transfer: audio/video information download
 - Mobile \leftrightarrow A/V appliance: data transfer: audio/video information download
 - Mobile \leftrightarrow computer: data transfer: audio/video information download

OPERATION SCENARIOS

MOBILE – MOBILE (2)

- **Simplicity for network set up** is important *
 - The complexities of setting up network connections between devices to be avoided: Cumbersome network settings certainly not in the consumer electronics world.
 - For an example, now, to set up Bluetooth communication between two computers it is needed to set it up manually with a password to protect the communication.
 - Network initiation: should be easy to simplify the set-up: **by any device: needs networking, but just addressing will be enough.**
- Simpler network set up and higher data rates needed**

* ecma tc32-tg19-2005-012

OPERATION SCENARIOS

INFRA – MOBILE (IN/LOW SPEED)

- Type of devices:
 - Two-way communicator (infra) and reactor (mobile)
 - Master and slave or primary and secondary
 - Infra : master or primary
 - Mobile: slave or secondary
- Operating mode: 10 m max
 - Active communication mode: **two-way communications**
 - Passive communication mode : **one-way broadcasting**
- Type of information delivered
 - Low speed applications: identification and simple information exchange
 - Infra → mobile: simple identification request, local information
 - Mobile → infra: simple id response
- Simplicity is important
 - It is important not to face the complexities of setting up network connections between devices.

OPERATION SCENARIOS

INFRA – MOBILE (IN/HIGH SPEED)

- Type of devices:
 - Two-way communicator (infra) and reactor (mobile)
 - Master and slave or primary and secondary
 - Infra : master or primary or access point
 - Mobile: slave or secondary
- Operating mode: 10 m max
 - Active communication mode: **two-way communications**
 - Passive communication mode : **one-way broadcasting**
- Type of information delivered
 - High speed applications: mainly WLAN applications
 - Infra → mobile: data transfer /exchange
 - Mobile → infra: data transfer /exchange

OPERATION SCENARIOS

INFRA – MOBILE (OUTDOOR)

- Type of devices
 - Two-way communicator (infra) and reactor (mobile)
 - Master and slave or primary and secondary
 - Infra : master or primary
 - mobile: slave or secondary
- Operating mode
 - Active communication mode: **two-way communications**
 - Passive communication mode: **one-way broadcasting**
- Network initiation: **only addressing is enough.**
- Type of information delivered: relatively simple information
 - Infra → mobile: local information, traffic information, etc.
 - Mobile → infra: information request, road state information collected including accident information, emergency information

OPERATION SCENARIOS COMMON TO MOST OF APPLICATIONS

- Collision avoidance
 - Method to **detect the presence of a VLC signal based on the pseudo random code matching** and method to detect and resolve collisions on protocol level
- Sensing
 - Method to sense a signal by a device in the Active communication mode it is supposed to receive
- Single Device Detection (SDD) or device discovery
 - An algorithm used by the initiator to detect one out of several reactors in its FOV
 - Device selection and de-selection needed

TECHNICAL REQUIREMENTS, TRAFFIC LIGHTS - VEHICLE (1)

- Bi-directional/asymmetric links
 - Downlink:
 - Frame size: 100 bytes = 800 bits, 10ms
 - Every 500 ms
 - 800 bits/10 ms = 80 Kbps, duty cycle = 2 %
 - Uplink:
 - Frame size: 50 bytes = 400 bits, 10ms
 - Vehicle transmits at every intersection.
 - 400 bits/10ms = 40 Kbps
 - TDD or FDD or CDD (?)
- Transmitter intensity: refer to a document presented in Jan. 2009 for intensities, 15-09-0052-01
 - Traffic light: strong intensity (?)*
 - Vehicle (not Headlights): strong intensity (?)* extra LEDs needed which will be installed near the edge of front windshield rather than headlights
- Sensitivity of Receiver/light sensor at traffic light/vehicle: image sensors/mobile phone used for sensors
 - At Traffic light: TBD or to be investigated
 - At Vehicle: TBD or to be investigated
- Range: 50 m max*

TECHNICAL REQUIREMENTS, TRAFFIC LIGHTS - VEHICLE (2)

- PTP or PTMP vs FOV: adaptive headlight can be considered
 - Single- or multi-directional transmission/reception: to be considered for future use: beam steering or beam arraying
 - Transmission to multiple points and/or reception from multiple sources
 - Wide beam pattern* (or multiple narrow beam ?)
 - Beam width at traffic lights: 45 degree
 - Beam width at vehicle: 90 degree
- Channels*
 - Outdoors: daytime or evening/night
 - LOS
- Automatic device discovery & beam pointing*
 - Automatic traffic light discovery and beam pointing by vehicle
- WPAN networking*
 - Networking needed for extension of ranges using vehicle to vehicle communications
- 150 KPH mobility*

* 15-09-0450-00-0007-vlc-application-iscupd-1

TECHNICAL REQUIREMENTS, VEHICLE-VEHICLE (1)

- Bi-directional/symmetric links
 - Downlink/uplink
 - Frame size: 100 bytes=800 bits, 10ms
 - Every 500 ms
 - 800 bits/10 ms = 80 Kbps, duty cycle = 2 %
 - ~100 Kbps*
 - Full duplex or half duplex (?):TDD or FDD or CDD (?)
- Transmitter intensity : refer to a document presented in Jan. 2009 for intensities, 15-09-0052-01
 - Headlights: strong intensity (?)*
 - Tail lights: strong intensity (?)*
- Receiver/light sensor at vehicle
 - Headlights: TBD
 - Tail lights: TBD
- Range: 100 m*

TECHNICAL REQUIREMENTS, VEHICLE-VEHICLE (2)

- PTP or PTMP vs FOV
 - Single- or multi-directional transmission/reception
 - Transmission to multiple points and/or reception from multiple sources
 - Wide beam pattern* (or multiple narrow beam ?)
- Channels*
 - Outdoors
 - LOS
- Automatic device discovery & beam pointing*
 - Automatic traffic light discovery and beam pointing by vehicle
- WPAN networking*
 - Networking needed for extension of ranges using vehicle to vehicle communications
- 300 KPH mobility*

* 15-09-0450-00-0007-vlc-application-iscupd-1

TECHNICAL REQUIREMENTS, COMMON FOR MOST APPLICATIONS (1)

- Transfer speeds
 - Various speeds changeable during communications or the best speeds selected by devices: **speed adaptive to applications/situations**
 - An algorithm needed to select transfer speed
 - By measuring light intensity received (?)
 - By measuring error rates (?)
 - Modulation schemes and bit encoding related
- Start and end of communications
 - Initialization or activation
 - Data exchange
 - De-selection or deactivation
- **Simple implementation**

TECHNICAL REQUIREMENTS, COMMON FOR MOST APPLICATIONS (2)

- Bit and byte representation
 - Bit coding: line coding
 - Byte coding : LSB first or MSB first
- Full duplex or half duplex (?)
- Framing
- Error control
- Network forming (set up)
 - Role of a device in a network
 - Initiator and targets or equal chance devices: The Initiator initiates and controls the exchange of data. The Target answers the request from the Initiator. *
- Cease of communication
 - By initiator or when moved out of range

* ecma tc32-tg19-2005-012

TECHNICAL REQUIREMENTS, COMMON FOR MOST APPLICATIONS (4)

- Modulation schemes and Transfer speeds

Comm. mode	Bit rate	Modulation scheme	Brightness control
Mobile - mobile	100 Mbps	Higher efficient	no
Infra – fixed/mobile (indoor, high speed)	10 Mbps	Higher efficient	yes
Infra – mobile (indoor, low speed)	100 Kbps	Lower efficient	no
Infra – mobile (outdoor)	100 Kbps	Lower efficient	no
Vehicle - vehicle	100 Kbps	Lower efficient	no
Traffic light/infra - vehicle	100 Kbps	Lower efficient	no

FRAME STRUCTURES AND ARCHITECTURES

COMMUNICATION SCENARIOS

COMMON STRUCTURE (1)

- Common superframe structure 1
 - Every x seconds, one preamble, one DL and one UL are transmitted.
 - Each (DL + UL) has a common preamble frame with common modulation and data rate for all applications. Each application may have a different PPDU structure with different modulation and data rate.

Down link

Common preamble, 128 byte = 1000 bits
 PPDU y bytes = $8 \times y$ bits
 Communication time for preamble = 5 ms
 Broadcast or a frame for one user every x

Up link

PPDU z bytes = $8 \times z$ bits
 UL PPDU assigned for a user per request using ACK/NACK

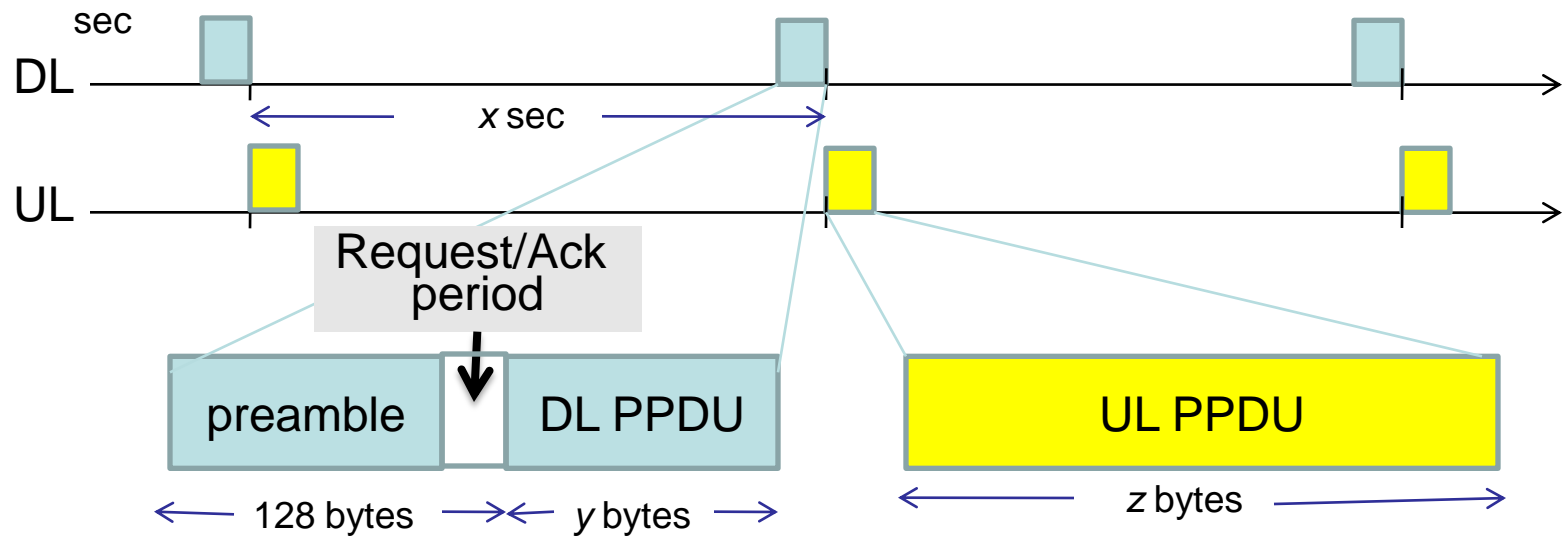

COMMUNICATION SCENARIOS COMMON STRUCTURE (2)

- Common superframe structure 2
 - A superframe consists of a common preamble, SCH and multiple frames.
 - Each frame has a DL and a UL subframes: a common preamble frame with common modulation and data rate for all applications. Each application may have a different PPDU structure with different modulation and data rate.

- Down link

Common preamble 128 byte = 1000 bits
 Communication time for preamble = 5 ms
 TDD

- Up link

Demand assigned TDMA
Or CDMA with 16 bit Walsh code

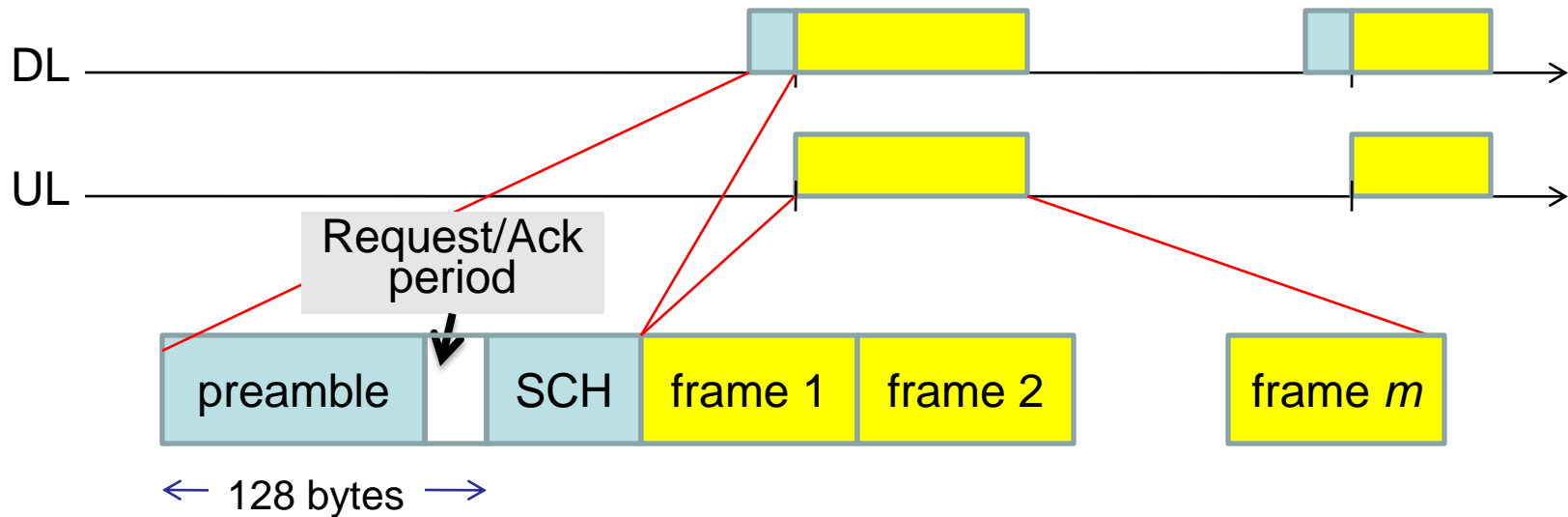

COMMUNICATION SCENARIOS

COMMON STRUCTURE (3)

- Common (Preamble + Request/Ack period) structure
 - Superframes for all applications have a common preamble, frame and may have different PPDU structure for each application.
 - Preamble frame for frame sync, and Request/Ack period (RAP) for transmit request and ack/nack
 - Common quaternary modulation scheme and data rate of 200 Kbps applied
- only one preamble frame for each superframe

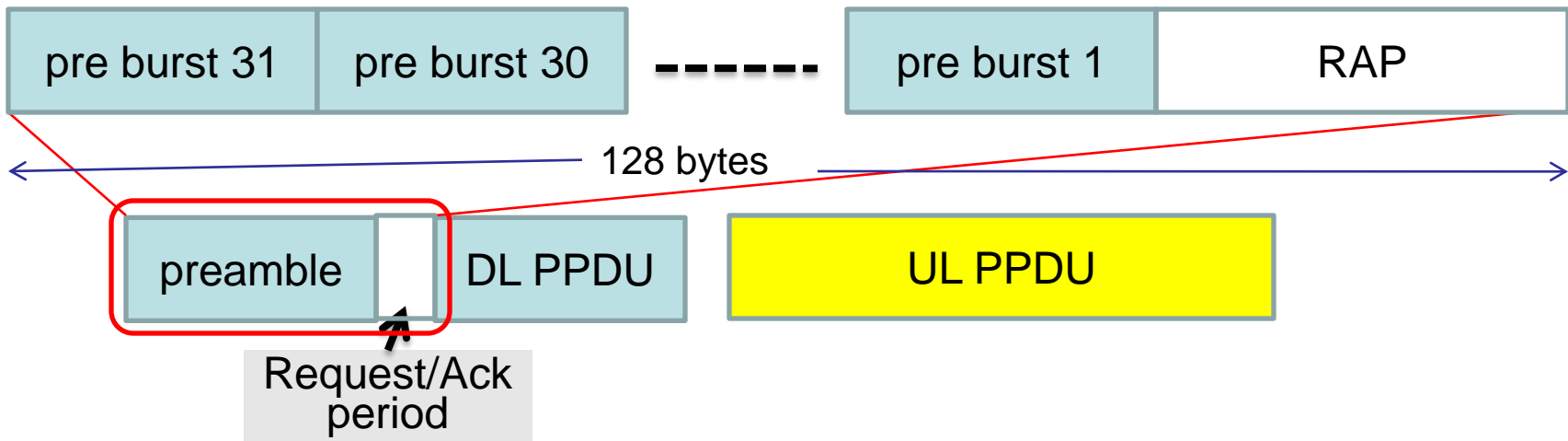

Communication time for PPDU depends on modulation scheme and data rate applied and its size.

COMMUNICATION SCENARIOS COMMON STRUCTURE (4)

- Common preamble burst structure
 - A preamble burst consists of a preamble word, an index, a parity, and a reserved word.
 - (Index +parity) uses (15,7) Hamming code.

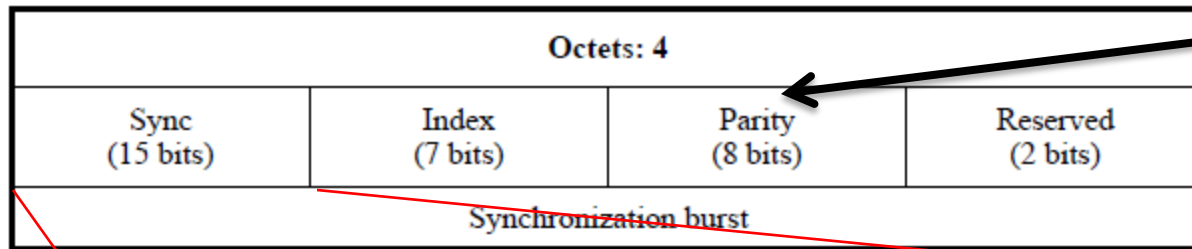
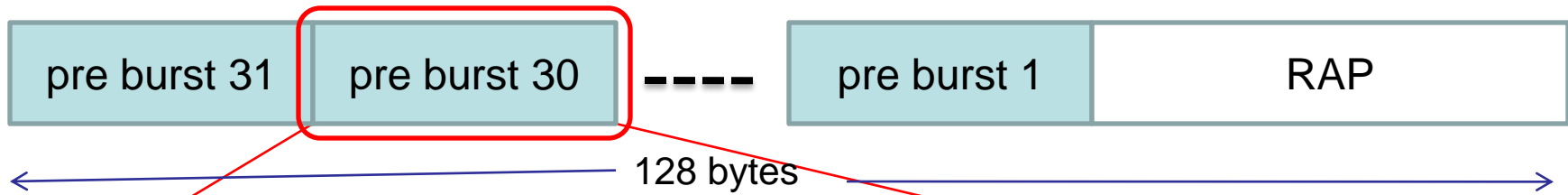

Bits	0	1	2	3	4	5	6	7	8	9	10	11	12	13	14
Name	s_0	s_1	s_2	s_3	s_4	s_5	s_6	s_7	s_8	s_9	s_{10}	s_{11}	s_{12}	s_{13}	s_{14}
Value	1	1	1	1	0	1	0	1	1	0	0	1	0	0	0

COMMUNICATION SCENARIOS COMMON STRUCTURE (5)

- The simulation results of 7-bit message without FEC and 15-bit with FEC(15,7) on the AWGN channel are plotted in the following figure. (imported from 22-07-053-01)

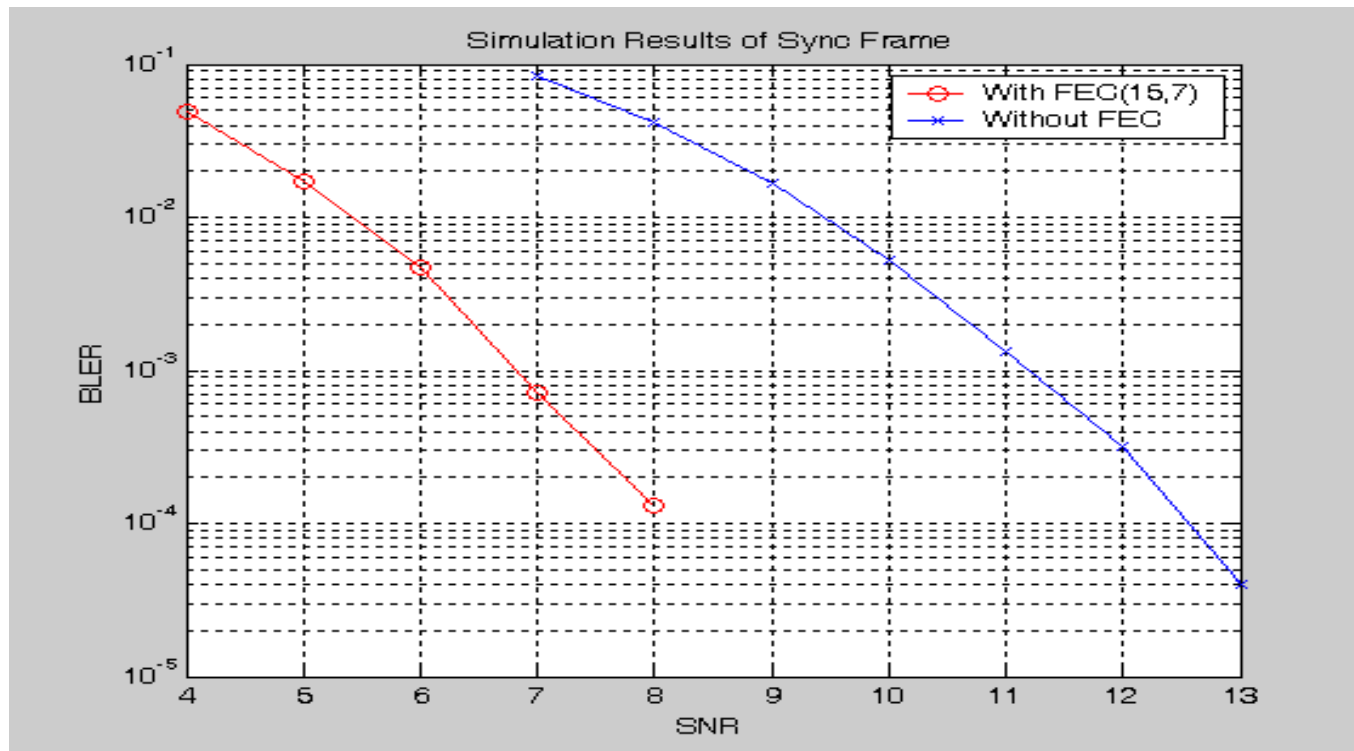

COMMUNICATION SCENARIOS COMMON STRUCTURE (6)

- Common Request/Ack period (RAP) structure
 - An RAP frame consists of an RTS burst and an ANP burst.
 - Each RTS or ANP burst consists of 16 bits.

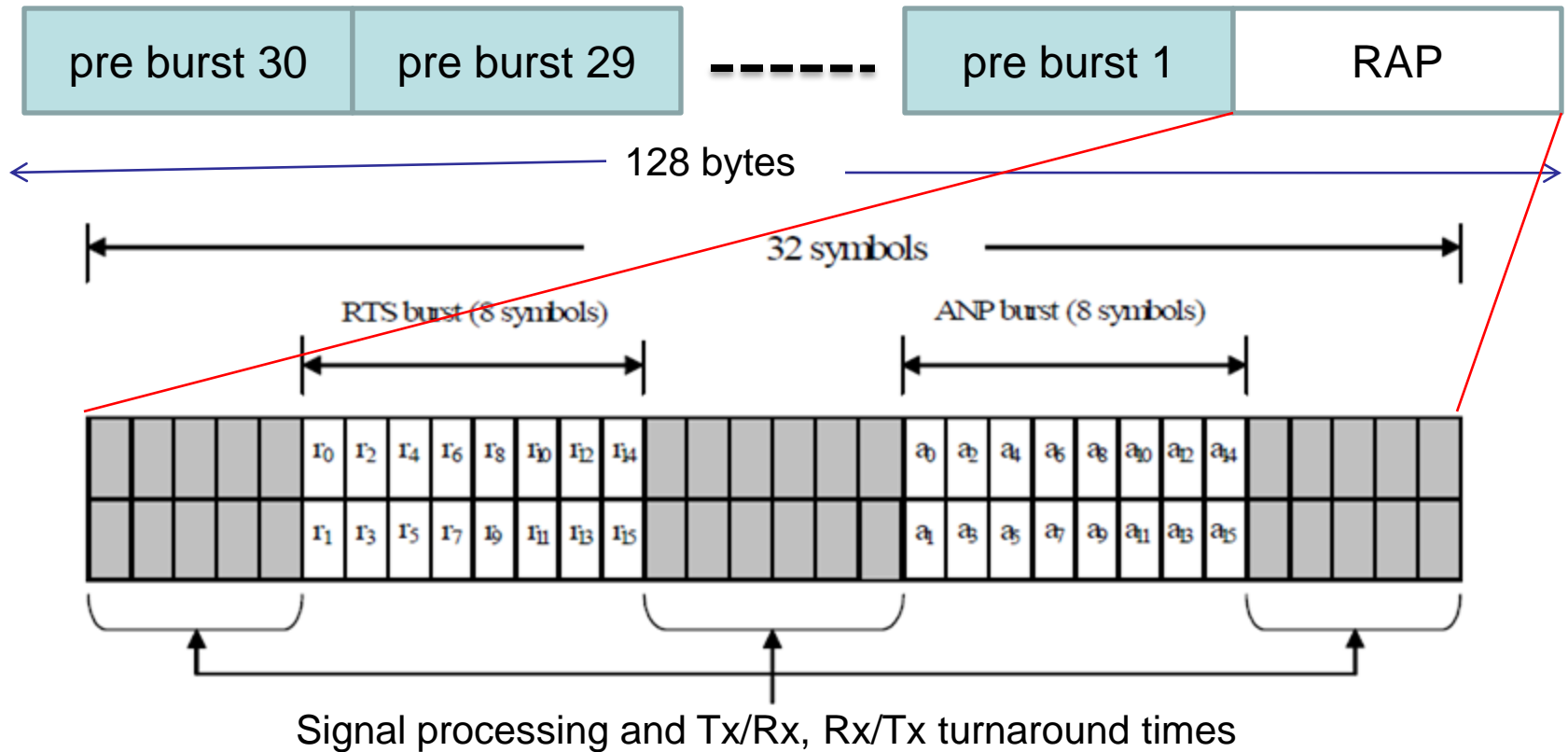

COMMUNICATION SCENARIOS

COMMON STRUCTURE (7)

- RTS and ANP code structure (1)
 - An RAP frame consists of an RTS burst and an ANP burst.
 - 64 16 bit codewords for RTS and ANP each
- Cascading two identical 8-bit orthogonal codes
- Received data: divided into two subcodewords

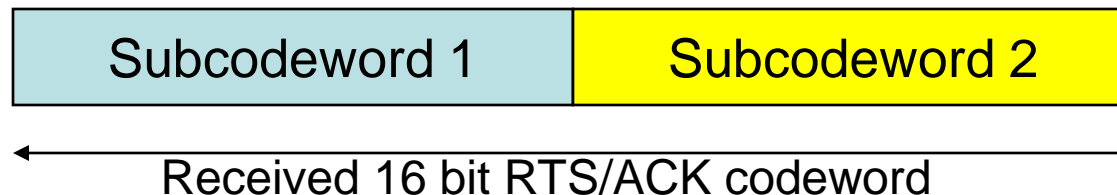

- Each subcodeword is compared with 8 8-bit codewords.
- $8 \times 8 = 64$ combinations of codewords realized
 - up to 64 devices can be associated to a network.

COMMUNICATION SCENARIOS

COMMON STRUCTURE (8)

- RTS and ANP code structure (2)
 - An RAP frame consists of an RTS burst and an ANP burst.
 - 64 16 bit codewords for RTS and ANP each to identify 64 users

For subcodeword 1

RTS/ACK index	r0	r1	r2	r3	r4	r5	r6	r7
1	0	0	0	0	0	0	0	0
2	0	1	0	1	0	1	0	1
3	0	0	1	1	0	0	1	1
4	0	1	1	0	0	1	1	0
5	0	0	0	0	1	1	1	1
6	0	1	0	1	1	0	1	0
7	0	0	1	1	1	1	0	0
8	0	1	1	0	1	0	0	1

For subcodeword 2

RTS/ACK index	r8	r9	r10	r11	r12	r13	r14	r15
1	0	0	0	0	0	0	0	0
2	0	1	0	1	0	1	0	1
3	0	0	1	1	0	0	1	1
4	0	1	1	0	0	1	1	0
5	0	0	0	0	1	1	1	1
6	0	1	0	1	1	0	1	0
7	0	0	1	1	1	1	0	0
8	0	1	1	0	1	0	0	1

COMMUNICATION SCENARIOS

TRAFFIC LIGHT (OR INFRA)-VEHICLE (1)

Simple Superframe structure 1 applied for low speed applications

- Down link: from traffic light or infra
 - payload 100 bytes = 800 bits
 - Communication time = 10ms
 - Every x msec
- Up link: from vehicle
 - payload 200 bytes = 1600 bits
 - Communication time = 10ms
 - Every x msec

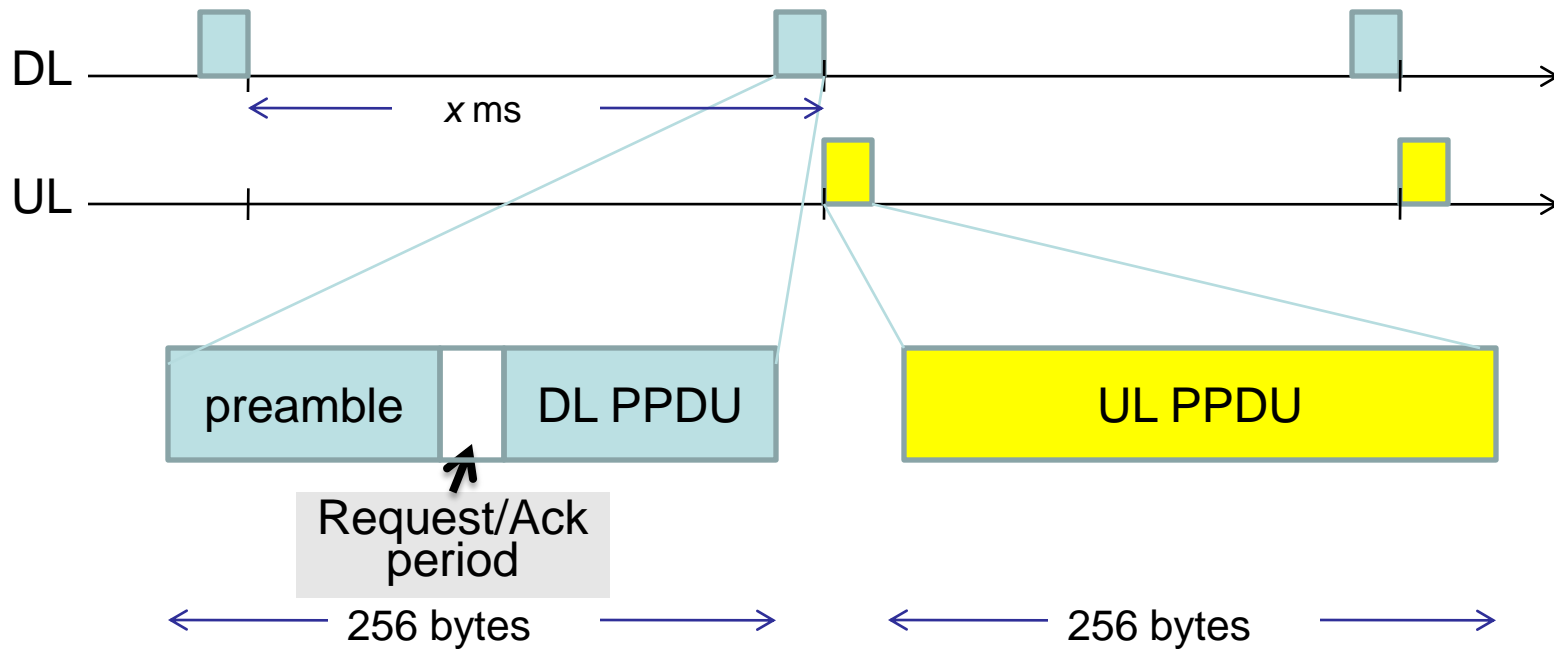

COMMUNICATION SCENARIOS

TRAFFIC LIGHT (OR INFRA)-VEHICLE (2)

- Down/up link
 - payload 100 bytes, total frame = (preamble 128 bytes + PPDU 128 bytes) = 256 bytes = 2 Kbits,
 - Communication time = 10ms, Every x msec \rightarrow data rate = 2 Kbits/10 ms = 200 Kbps
 - Max. range = 50 m

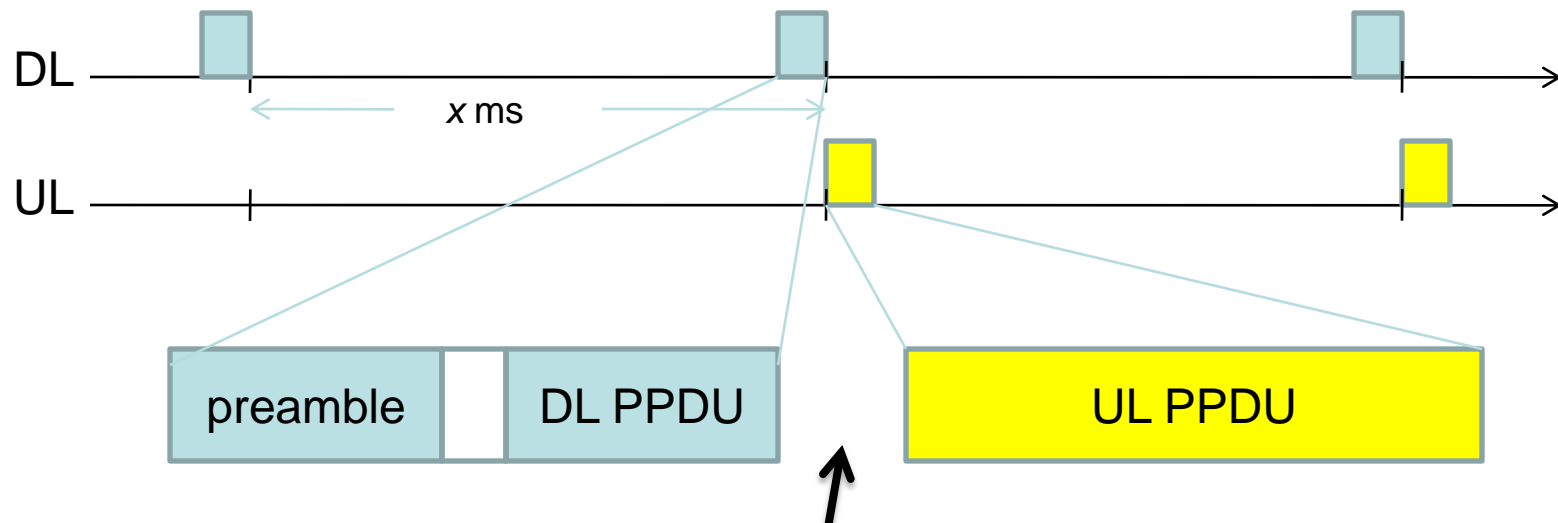

Max. latency/delay between down and up links = $100 \text{ m} / 3 \times 10^8 \text{ m} = .33 \text{ us}$
 10 us/symbol for quaternary modulation case \rightarrow latency negligible

COMMUNICATION SCENARIOS

TRAFFIC LIGHT (OR INFRA)–VEHICLE (3)

- Master – slave relationship:
 - traffic light (or infra): master, vehicles: slaves
- Modulation structure for each DL
 - payload 100 bytes, total frame = (preamble 128 bytes + PPDU 128 bytes) = 256 bytes = 2 Kbits,
 - Communication time = 10ms, Every x msec \rightarrow data rate = 2 Kbits/10 ms = 200 Kbps
 - Apply quaternary modulation such as QPSK \rightarrow 1 Ksymbols per frame
- Modulation structure for each UL
 - Same as for the case of DL except the length of the frame with max frame length of 256 bytes \rightarrow 1 Ksymbols per frame
- Symbol duration = 10 us, Max signal duration for both DL and UL = 20 ms, max. duty cycle = 4 % for every 500 ms transmission case



COMMUNICATION SCENARIOS

VEHICLE – VEHICLE (1)

Simple Superframe structure 1 applied for low speed applications

- Down link: from primary vehicle
 - payload 100 bytes = 800 bits
 - Communication time = 10ms
 - Every x msec
- Up link: from secondary vehicle
 - payload 100 bytes = 800 bits
 - Communication time = 10ms
 - Every x msec

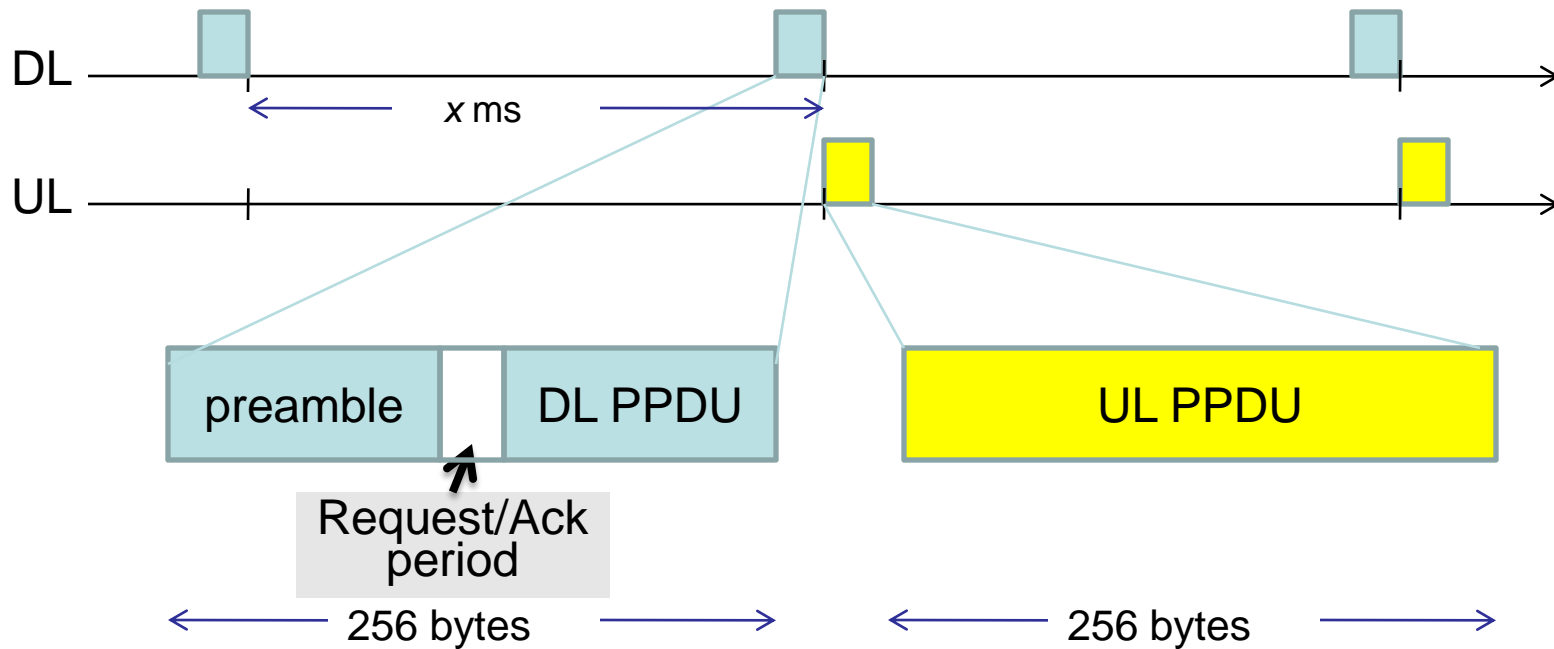

COMMUNICATION SCENARIOS

VEHICLE - VEHICLE (2)

- Down/up link

- payload 100 bytes, total frame = (preamble 128 bytes + PPDU 128 bytes) = 256 bytes = 2 Kbits,
- Communication time = 10ms, Every x msec \rightarrow data rate = 2 Kbits/10 ms = 200 Kbps
- Max. range = 50 m

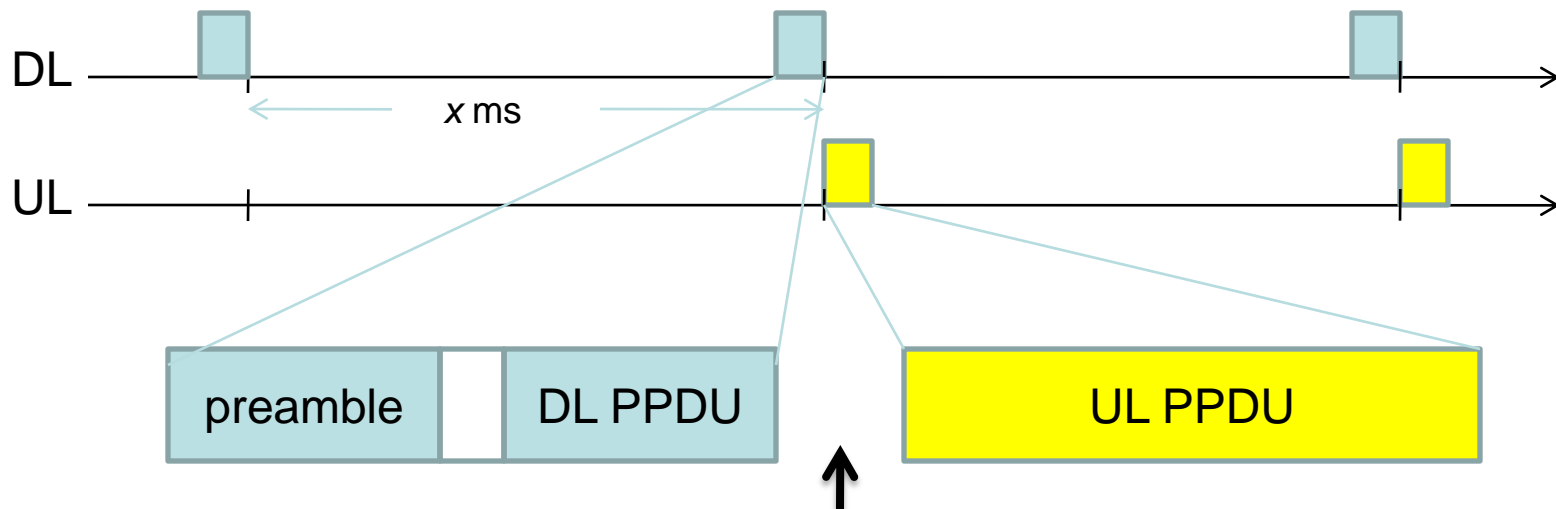

Max. latency/delay between down and up links = $100 \text{ m} / 3 \times 10^8 \text{ m} = .33 \text{ us}$
 10 us/symbol for quaternary modulation case \rightarrow latency negligible

COMMUNICATION SCENARIOS

VEHICLE - VEHICLE (3)

- Master – slave relationship:
 - Primary vehicle: master, secondary vehicles: slaves
- Modulation structure for each DL
 - payload 100 bytes, total frame = (preamble 128 bytes + PPDU 128 bytes) = 256 bytes = 2 Kbits,
 - Communication time = 10ms, Every x msec \rightarrow data rate = 2 Kbits/10 ms = 200 Kbps
 - Apply quaternary modulation such as QPSK \rightarrow 1 Ksymbols per frame
- Modulation structure for each UL
 - Same as for the case of DL except the length of the frame with max frame length of 256 bytes \rightarrow 1 Ksymbols per frame
- Symbol duration = 10 us, Max signal duration for both DL and UL = 20 ms, max. duty cycle = 4 % for every 500 ms transmission case



COMMUNICATION SCENARIOS

INFRA – MOBILE/FIXED: LOW SPEED (1)

Simple Superframe structure 1 applied for low speed applications

- Down link: from infra
 - payload 100 bytes = 800 bits
 - Communication time = 10ms
 - Every x msec

- Up link: from mobile/fixed
 - payload 200 bytes = 1600 bits
 - Communication time = 10ms
 - WHENEVER responses are requested

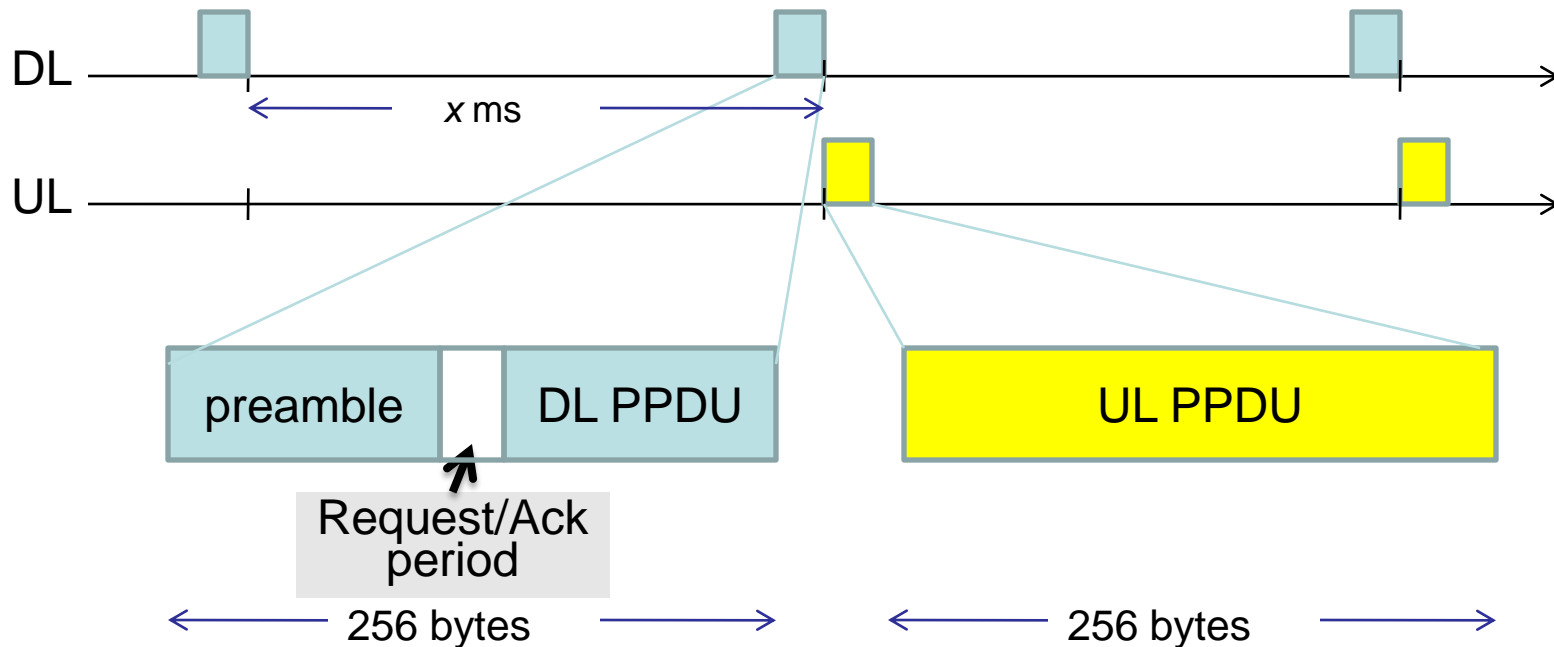

COMMUNICATION SCENARIOS

INFRA – MOBILE/FIXED: LOW SPEED (2)

- Down/up link
 - payload 100 bytes, total frame = (preamble 128 bytes + PPDU 128 bytes) = 256 bytes = 2 Kbits,
 - Communication time = 10ms, Every x msec \rightarrow data rate = 2 Kbits/10 ms = 200 Kbps
 - Max. range = 5 m

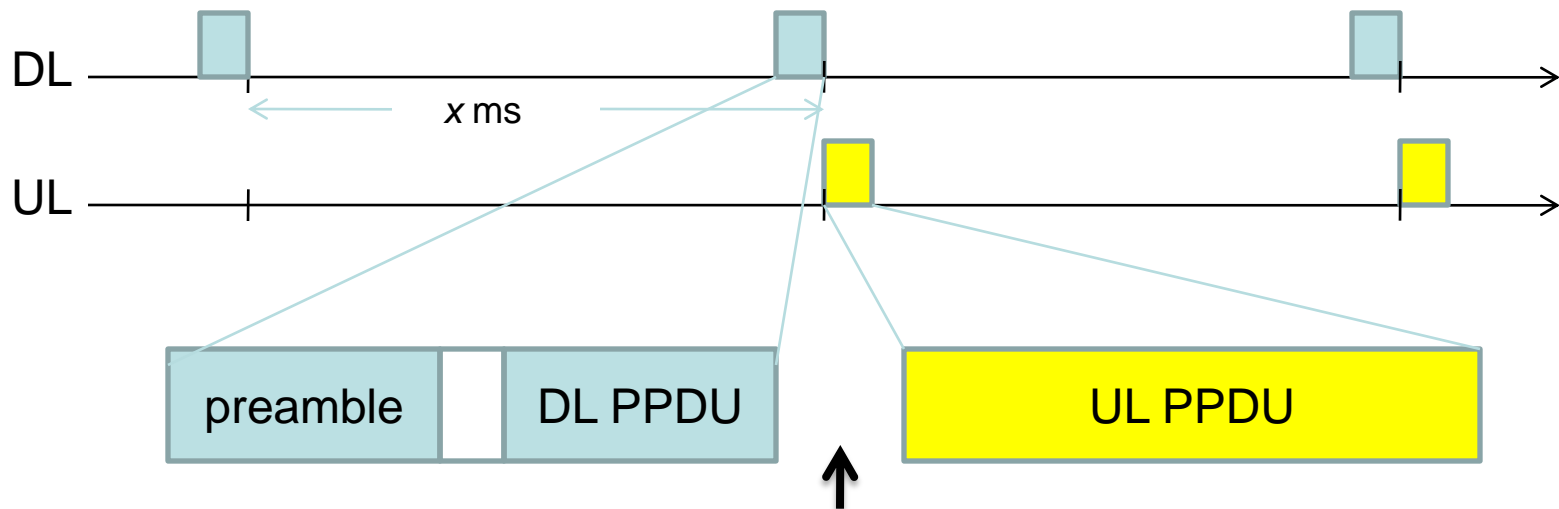

Max. latency/delay between down and up links = $10 \text{ m} / 3 \times 10^8 \text{ m} = .033 \text{ us}$
 10 us/symbol for quaternary modulation case \rightarrow latency negligible

COMMUNICATION SCENARIOS

INFRA – MOBILE/FIXED: LOW SPEED (3)

- Master – slave relationship:
 - infra: master, mobile/fixed: slave
- Modulation structure for each DL
 - payload 100 bytes, total frame = (preamble 128 bytes + PPDU 128 bytes) = 256 bytes = 2 Kbits,
 - Communication time = 10ms, Every x msec \rightarrow data rate = 2 Kbits/10 ms = 200 Kbps
 - Apply quaternary modulation such as QPSK \rightarrow 1 Ksymbols per frame
- Modulation structure for each UL
 - Same as for the case of DL except the length of the frame with max frame length of 256 bytes \rightarrow 1 Ksymbols per frame
- Symbol duration = 10 us, Max signal duration for both DL and UL = 20 ms, max. duty cycle = 4 % for every 500 ms transmission case



COMMUNICATION SCENARIOS

INFRA – MOBILE/FIXED: HIGH SPEED (1)

Complicated Superframe structure 2 applied for high speed applications such as WLAN

- Down link: from infra
 - Preamble frame can be used commonly as other applications.
 - Time division duplex (TDD)
- Up link: from mobile/fixed
 - Demand assigned TDMA

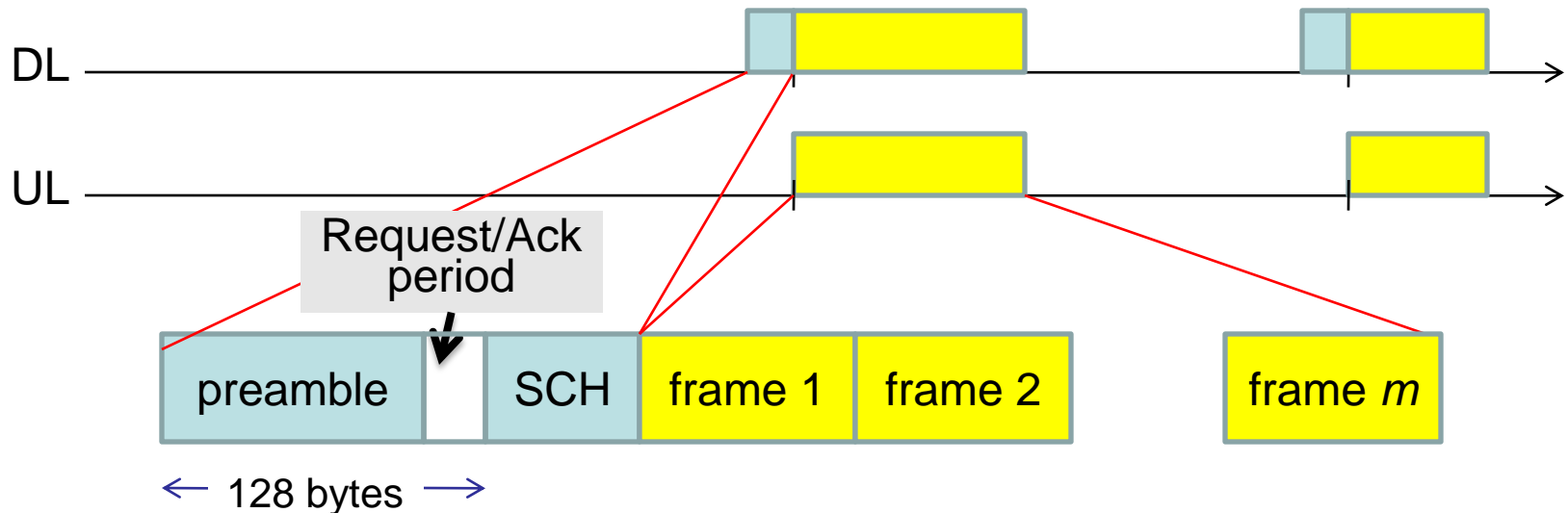

COMMUNICATION SCENARIOS

INFRA – MOBILE/FIXED: HIGH SPEED (2)

- Down/up link

- payload \gg 100 bytes, total frame = (preamble 128 bytes + PPDU \gg 128 bytes) = preamble 1 Kbits + long payload
- Communication time for preamble = 5 ms, \rightarrow data rate during preamble frame = 1 Kbits/5 ms = 200 Kbps: data rate during period other than preamble \gg 200 Kbps
- Max. range = 10 m

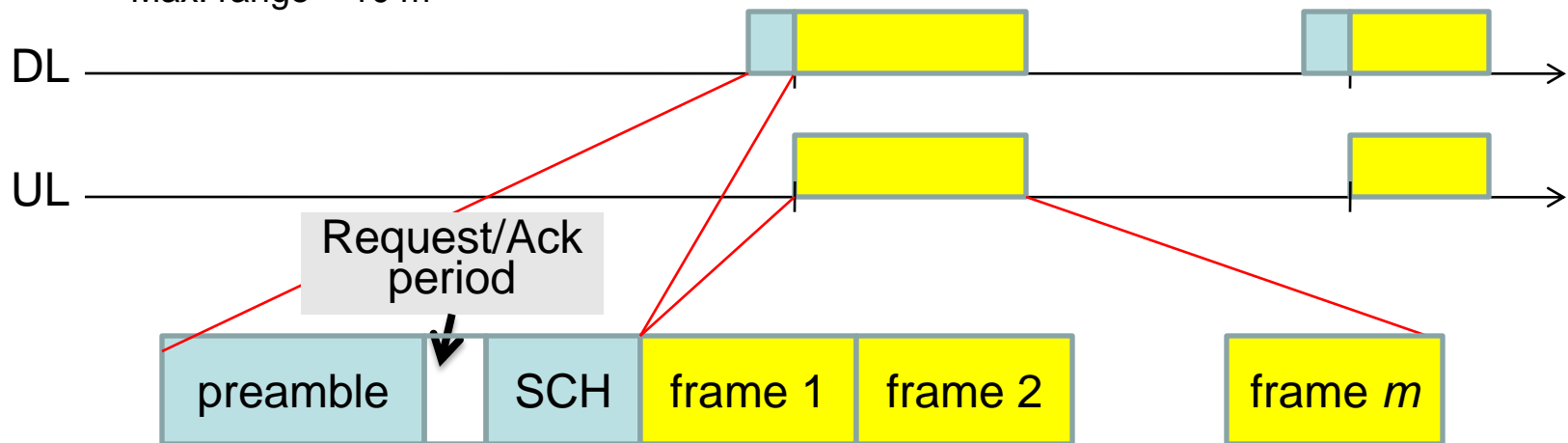

Max. latency between down and up links = $20 \text{ m} / 3 \times 10^8 \text{ m} = .066 \text{ us}$
 2 us/symbol for quaternary modulation case with 10 Mbps (worst case)
 \rightarrow latency negligible (?) \leftarrow apply higher efficient modulation scheme(s)

COMMUNICATION SCENARIOS

INFRA – MOBILE/FIXED: HIGH SPEED (3)

- Superframe
 - Defined and delimited by a preamble preamble and the SCH (superframe control header). It is comprised of a number of **Frames**
- Frame
 - Comprised of one DS and one US **Subframe**, where BS and CPEs use to communicate with each other
- Subframe
 - Formed by a number of **Bursts**
- Burst
 - It may comprise of multiple **MAC PDUs** belonging to multiple mobile/fixeds.
- MAC PDU
 - The smallest unit of transmission/reception by the MAC. It is comprised of the MAC header, the payload, and CRC



COMMUNICATION SCENARIOS

INFRA – MOBILE/FIXED: HIGH SPEED (4)

- Master – slave relationship:
 - infra: master, mobile/fixed: slave
- Modulation structure for each DL
 - payload \gg 100 bytes, total frame = (preamble 128 bytes + PPDU \gg 128 bytes) = preamble 1 Kbits + long payload
 - Communication time for preamble only = 5 ms \rightarrow data rate for preamble only = 1 Kbits/5 ms = 200 Kbps
 - Apply quaternary modulation such as QPSK for preamble only \rightarrow 1 Ksymbols per preamble frame; apply higher efficient modulation for other frames \rightarrow higher data rate for other frames
- Modulation structure for each UL
 - apply higher efficient modulation for data frames \rightarrow higher data rate for data frames
- Symbol duration for preamble only = 10 us, signal duration for preamble only = 5 ms

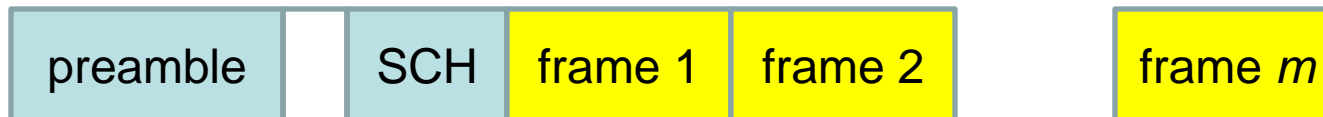

COMMUNICATION SCENARIOS

MOBILE/FIXED-MOBILE: HIGH SPEED (1)

Simple but long Superframe structure 2 needed to be applied for high speed applications such as file transfer

- Down link: from primary
Preamble frame can be used commonly as other applications.
- Up link: from mobile/fixed
Long payload with simple format

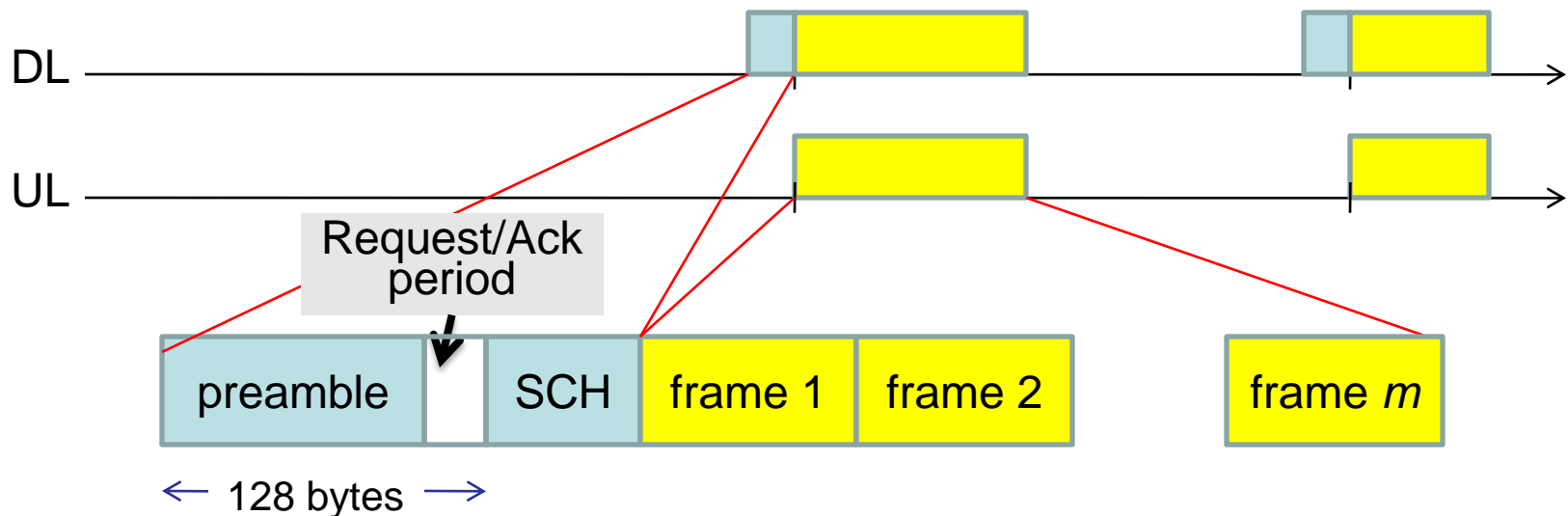

COMMUNICATION SCENARIOS

MOBILE/FIXED-MOBILE: HIGH SPEED (2)

- Down/up link
 - payload \gg 100 bytes, total frame = (preamble 128 bytes + PPDU \gg 128 bytes) = preamble 1 Kbits + long payload
 - Communication time for preamble = 5 ms, \rightarrow data rate during preamble frame = 1 Kbits/5 ms = 200 Kbps: data rate during period other than preamble \gg 200 Kbps
 - Max. range = 20 cm

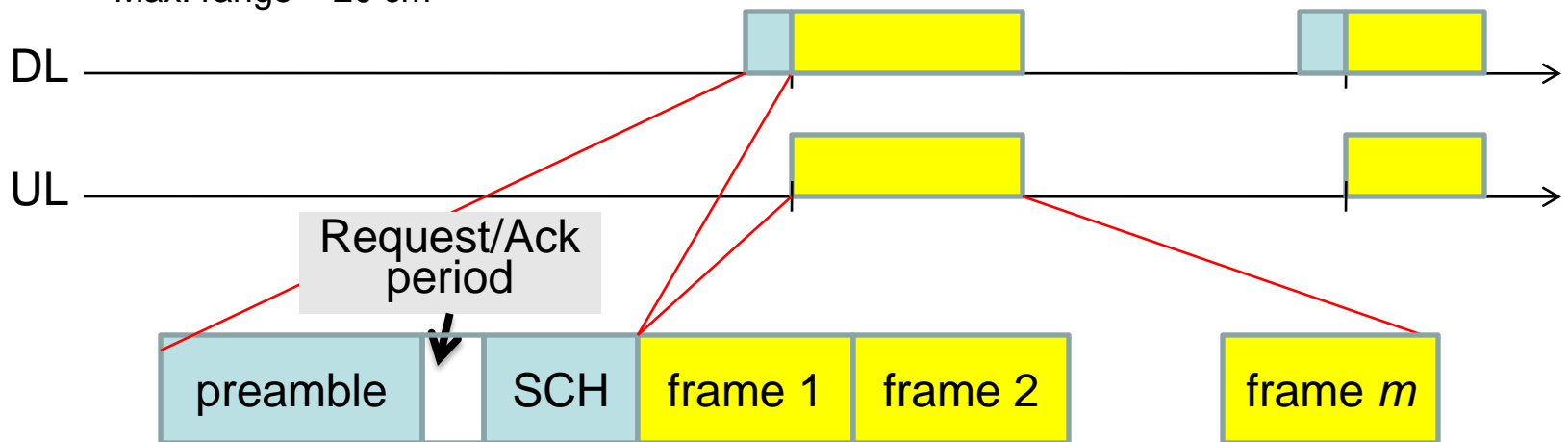

Max. latency/delay between down and up links = $.4 \text{ m} / 3 \times 10^8 \text{ m} = .0013 \text{ us}$
 $.002 \text{ us/symbol}$ for quaternary modulation case with 100 Mbps (worst case)
 \rightarrow latency not negligible (?) \leftarrow apply a high efficient modulation scheme

COMMUNICATION SCENARIOS

MOBILE/FIXED-MOBILE: HIGH SPEED (3)

- Master – slave relationship:
 - Primary mobile/fixed: master, secondary mobile/fixed: slave
- Modulation structure for each DL
 - payload \gg 100 bytes, total frame = (preamble 128 bytes + PPDU \gg 128 bytes) = preamble 1 Kbits + long payload
 - Communication time for preamble only = 5 ms \rightarrow data rate for preamble only = 1 Kbits/5 ms = 200 Kbps
 - Apply quaternary modulation such as QPSK for preamble only \rightarrow 1 Ksymbols per preamble frame; apply higher efficient modulation for data frames \rightarrow higher data rate for data frames
- Modulation structure for each UL
 - apply higher efficient modulation for data frames \rightarrow higher data rate for data frames
- Symbol duration for preamble only = 10 μ s, signal duration for preamble only = 5 ms



CONSIDERATIONS ON VLC LAYER ARCHITECTURE *

- Splitting PHY into two parts – VLC part and light emitting device control part - was considered when existing illumination systems are utilized as light sources of VLC.
- Layer architecture totally depends on what technologies will be used for the 15.7 standard without splitting PHY.
 - Including modulation techniques
 - What happens if modulation technique applied does not depend on technical characteristics of LED deployed? → **new modulation scheme needed**
 - What problem if only simple current or voltage control is needed to the LED control panel for VLC? This control can be implemented even for existing LED lighting systems already deployed. → **another small layer introduced (LAL)**
- Basically it is more desirable that the standard for VLC be independent of lighting systems.
 - The VLC should be coexistent with or adapted to any (infrastructure) lighting systems. To do this, simple inputs are allowed to be inputted to the lighting controller.

* 15-09-0557-01-0007-structures-without-PHY-splitting

VLC LAYER ARCHITECTURES

- Architecture that are being presented for VLC through illumination
 - Import from the previous presentation: 15-09-0557-01-0007-structures-without-PHY-splitting

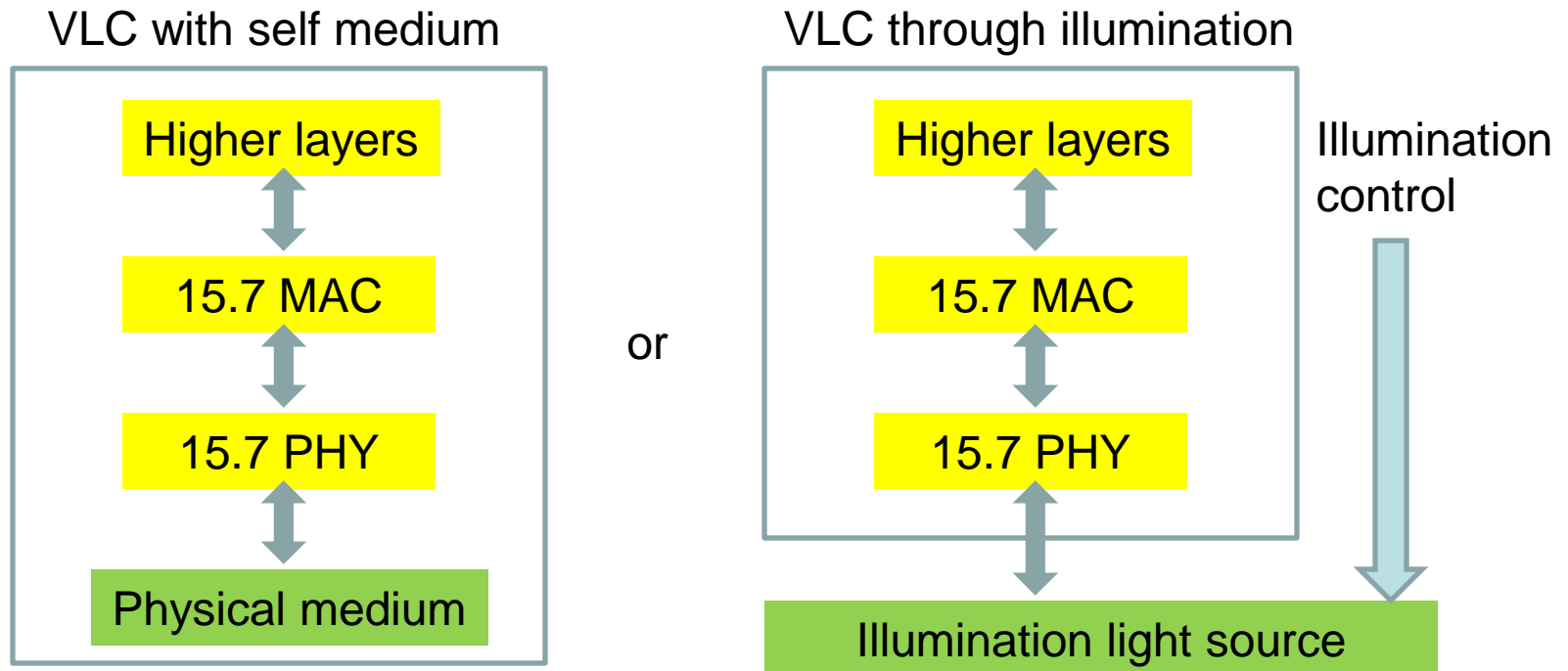

* 15-09-0557-01-0007-structures-without-PHY-splitting

VLC LAYER ARCHITECTURE 1*

- **Architecture 1**: using light abstraction layer (LAL)

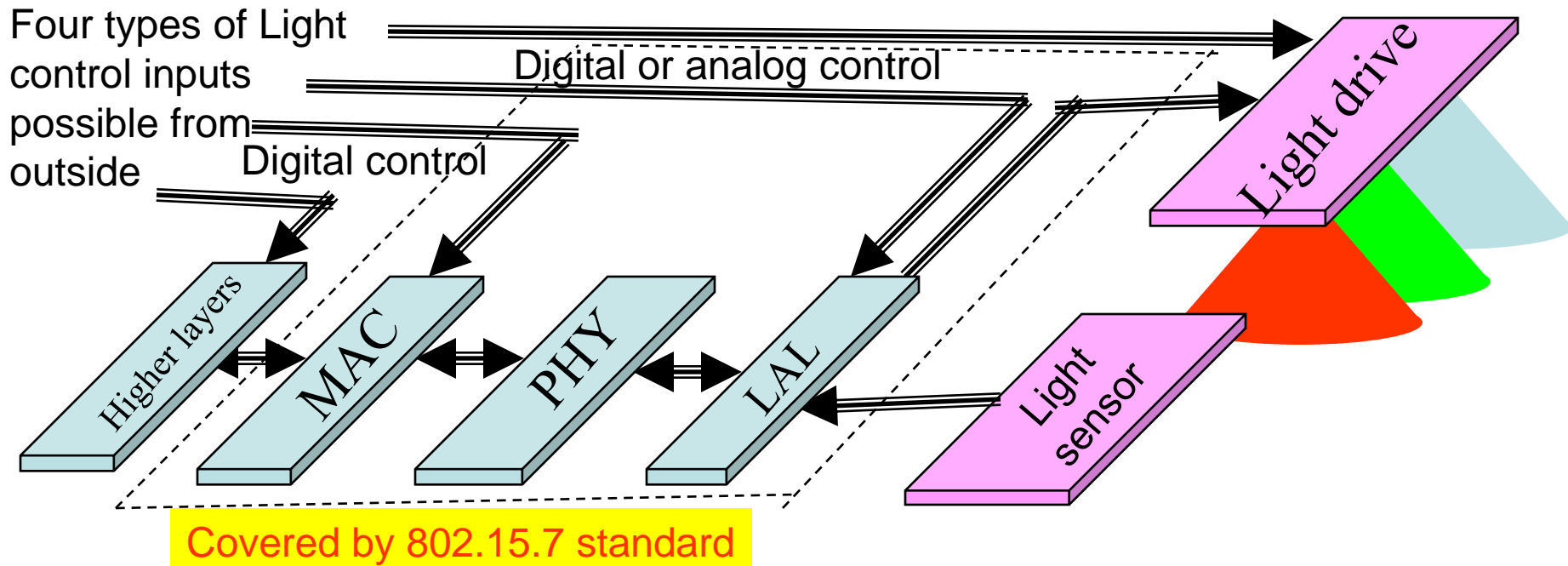

Lighting system is not a part of VLC: a stand-alone lighting system already deployed.

For multi-hop cases, a repeater will select a medium for proper routing, so light control can be inputted to MAC.

VLC LAYER ARCHITECTURE 2*

- **Architecture 2:** without using light abstraction layer (LAL)

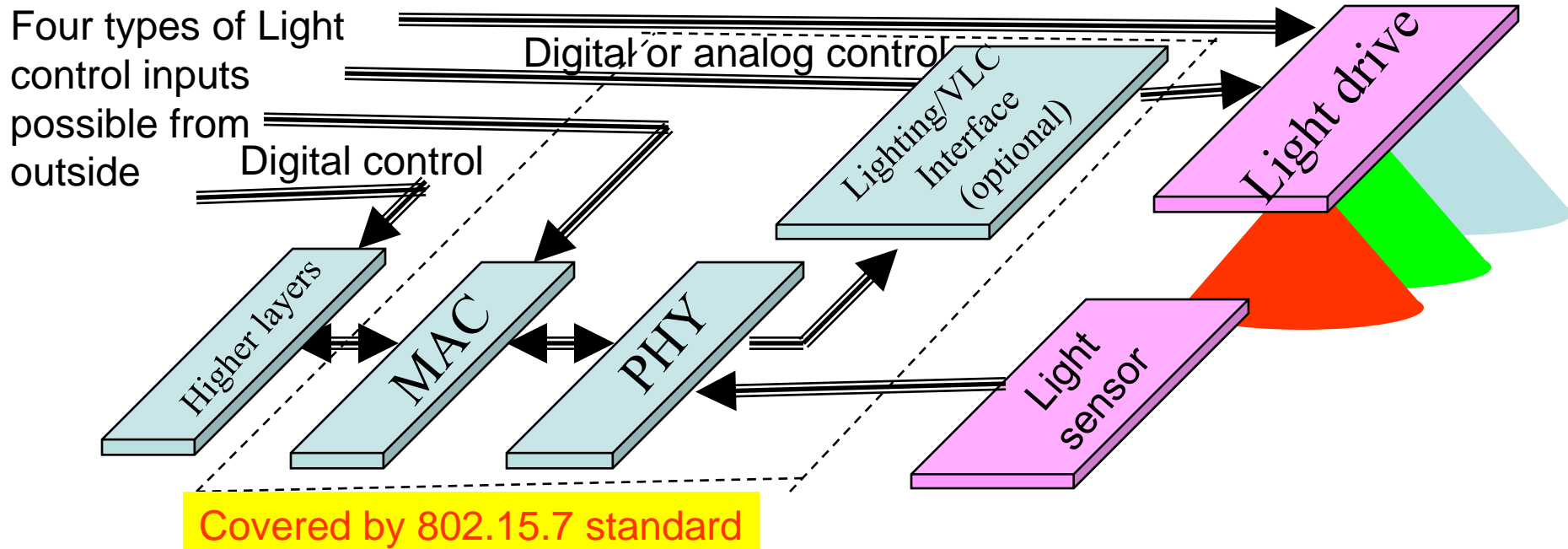

Lighting system is not a part of VLC: a stand-alone lighting system already deployed.

For multi-hop cases, a repeater will select a medium for proper routing, so light control can be inputted to MAC.

FUNCTIONS OF EACH LEVEL OF LAYERS

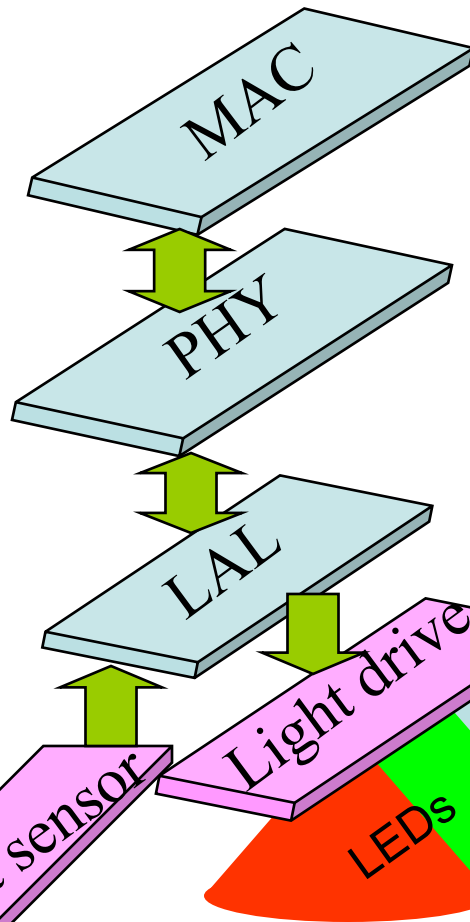

- MAC level control for PHY and VLC communications
- Communication with next higher layer
- Lighting control (optional)

- Simple LED input to deliver information transmitted
- Facilitate modulation of light signals
- Reception of signal information from photo detectors
- Lighting control (optional)
- Communication with MAC

- Less PHY overhead incurred by lighting
- Easy to combine signals from VLC and lighting

- Provide power to drive LEDs
- Brightness control if needed
- Flexible selection of light sensors as PD, IS, etc

- Emission of light controlled by light drive
- Detecting of light controlled by light sensor

* 15-09-0557-01-0007-structures-without-PHY-splitting

MODULATION

CONSIDERATIONS FOR MODULATION

- Need of brightness control or not
 - Needs to provide superior brightness for visible communications?
 - It is more desirable for performance not to be affected by brightness control.
- Dependency of LED characteristics
 - Modulation technique applied is not dependent on technical characteristics of LED deployed.
- Not (or negligibly) affected by background noise or not
 - Offsetting the impact of background lights
 - Stable data transmission should be provided even if the background noise is strong.
 - Offers high robustness to background light
- Data speed
 - Low to high data rates to be realized: adaptive to the amount of information delivered
 - **Adaptiveness** of data speed is important.

MAJOR DISTINCTIONS BETWEEN VLC AND RADIO COMMUNICATION

VLC	Radio comm.
Data delivery by manipulating and measuring light, in terms of its <i>perceived brightness or colors to human eyes</i> . The radiant power at each wavelength is weighted by a luminosity function (a.k.a. visual sensitivity function) that models human brightness sensitivity.	Data delivery by manipulating electromagnetic signals and detecting parameters of the received signals or measuring radiant energy in terms of absolute power .
A light signal which will be manipulated for data delivery has a certain amount of frequency (or wavelength) band before modulation .	A carrier signal usually has a single frequency component which is modulated with data. Eventually the transmitted signal has a certain amount of band after modulation.

FACTORS CONSIDERED FOR VLC MODULATION (1)

- Eye sensitivity
 - To generate light with a color which is recognized by human eyes
 - Human eyes have different sensitivity for each wavelength: chromonicity functions reflect human eyes' sensitivity for various wavelengths.
 - **To determine colors recognized by human eyes after modulation**
- Spectral distribution of light emitting devices or light sources
 - To realize colors to be recognized by human eyes
- Light color spaces
 - In a constellation plane of a modulation scheme, to determine a possible area of the points where most efficient modulation can be realized, light color spaces can be defined.
 - To mix multiple colors to generate a target color, a set of color coordination coefficients in a light color space can be considered to define intensities of available color components.

FACTORS CONSIDERED FOR VLC MODULATION (2)

- Responsivities of photo detectors
 - Photo detectors have different responsivities for each wavelength.
 - At the receiver, post emphasis may be needed to compensate perceptual non-uniformity.
- Colors or comfortableness of light output from light emitting devices after modulation
 - After modulation, any target color should be able to be generated: **to human eyes.**
 - To mix multiple colors to generate any target color, a set of **color coordination coefficients (or intensities of light sources)** should be considered.
- Communications should not degrade illumination efficiency.
 - **Compatible with dimming: no or minimum performance degradation due to dimming**
- Efficiency of constellation map in a light color space after considering all factors
 - The above factors should be considered to design a constellation map, given a target color and the number of constellation points.

BASIC CONCEPT: MULTI COORDINATES TO REPRESENT COLORS (1)

- In the modulation scheme suggested in this document, two coordinates (x and y) for a two dimensional light color space are considered.
 - x and y are designed to be orthogonal to each other to be applied for the scheme:
 - No correlation between these two.
 - Any point in a space can be represented by a unique pair of these values.
 - A color is represented by a unique point in a space, not by multiple points.
 - Similar to QAM
 - Determine points which maximize the minimum distance among distances between any two points.
 - Equi-distance strategy is a possible way to assign points.

BASIC CONCEPT: MULTI COORDINATES TO REPRESENT COLORS (2)

- A color can be generated by mixing lights from multiple light emitting devices such as LEDs: **multiple light sources based, not single light source based**
 - It is not necessary that light of a color can be generated by mixing lights from multiple light emitting devices with a unique set of light intensities of light emitting devices.
 - A multi dimensional space can be considered to represent colors.
 - A multi dimensional light color space can be used for color representation, but generally it is not true that there is only one point to represent each color: multiple points can be identified for a specific color in general.
 - Thus a light space should be well tailored not to have multiple points to represent a color, but to represent a color with a unique point.

MODULATION BLOCKS

- Transmitter

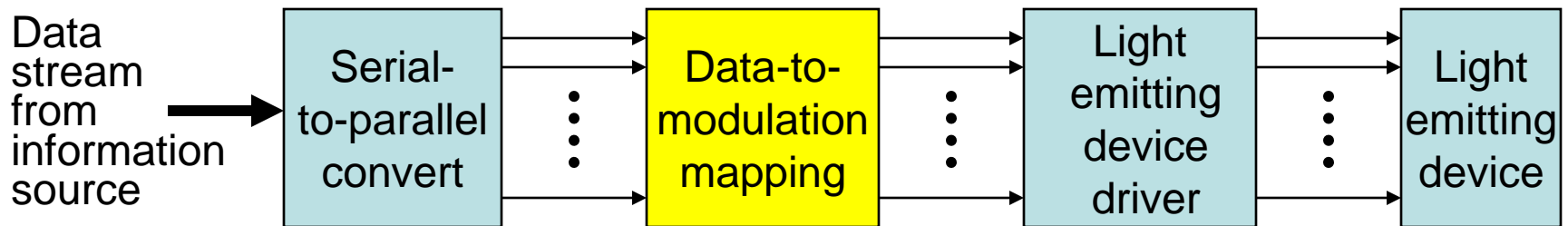

- Receiver

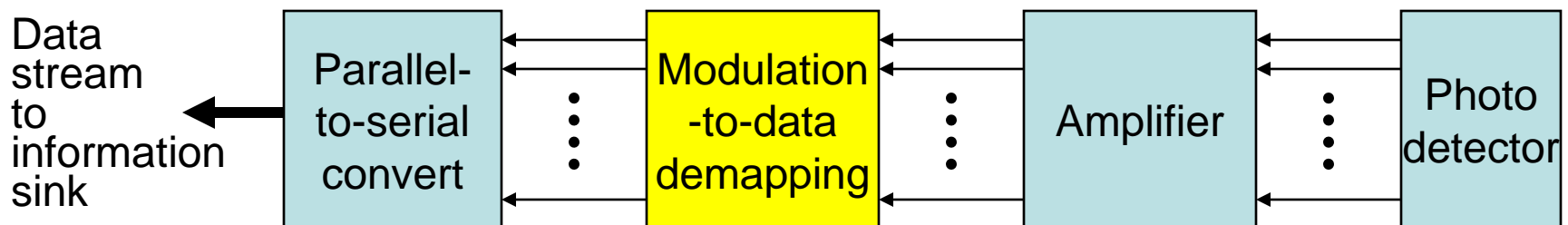

Light with a
color
recognized by
human eyes

CIE 1931 COLOR SPACE (1)

The CIE xyY chromaticity diagram and the CIE xyY color space

- The outer curved boundary is the spectral (or monochromatic) locus, with wavelengths shown in nanometers.
- The concept of color can be divided into two parts: brightness and chromaticity.
- The Y parameter is a measure of the brightness or luminance of a color.

$$x = \frac{X}{X + Y + Z}$$

$$y = \frac{Y}{X + Y + Z}$$

$$z = \frac{Z}{X + Y + Z} = 1 - x - y$$

$$X = \frac{Y}{y}x$$

$$Z = \frac{Y}{y}(1 - x - y)$$

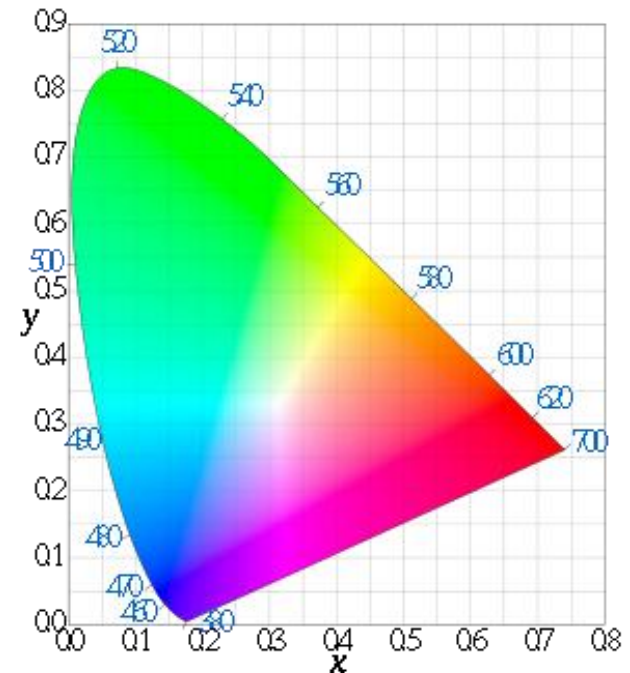

CIE 1931 COLOR SPACE (2)

One important fact on CIE xyY color space (2)

The CIE 1960, CIE 1964, and CIE 1976 color spaces were developed, with the goal of achieving perceptual uniformity (to have an equal distance in the color space correspond to equal differences in color). Although they were a distinct improvement over the CIE 1931 system, they were not completely free of distortion.

→ To utilize better perceptual uniformity, the **CIE 1976** is more appropriate for a color space for modulation schemes using the constellation planes in a light color space including one suggested in this document. And also it has less area that can not be covered by a triangle made with any three point colors.

Another fact on primary colors

Any choice of primary colors is essentially arbitrary; for example, an early color photographic process, autochrome, typically used orange, green, and violet primaries.

1976 CIE $u'v'$ COLOR SPACE

1976 CIE $u'v'$ (or CIE LUV) Chromaticity Diagram (1)

- The advantage of the 1976 diagram is that the distance between points is now approximately proportional to the perceived color difference, something definitely not true in the 1931 diagram.
- attempted perceptual uniformity
- additive mixtures of different colored lights will fall on a line in CIE LUV 's uniform chromaticity diagram **with a condition that the mixtures are constant in lightness.**
- Historical inertia has won out over technical superiority: the 1976 diagram is not used as much as the original 1931 diagram.

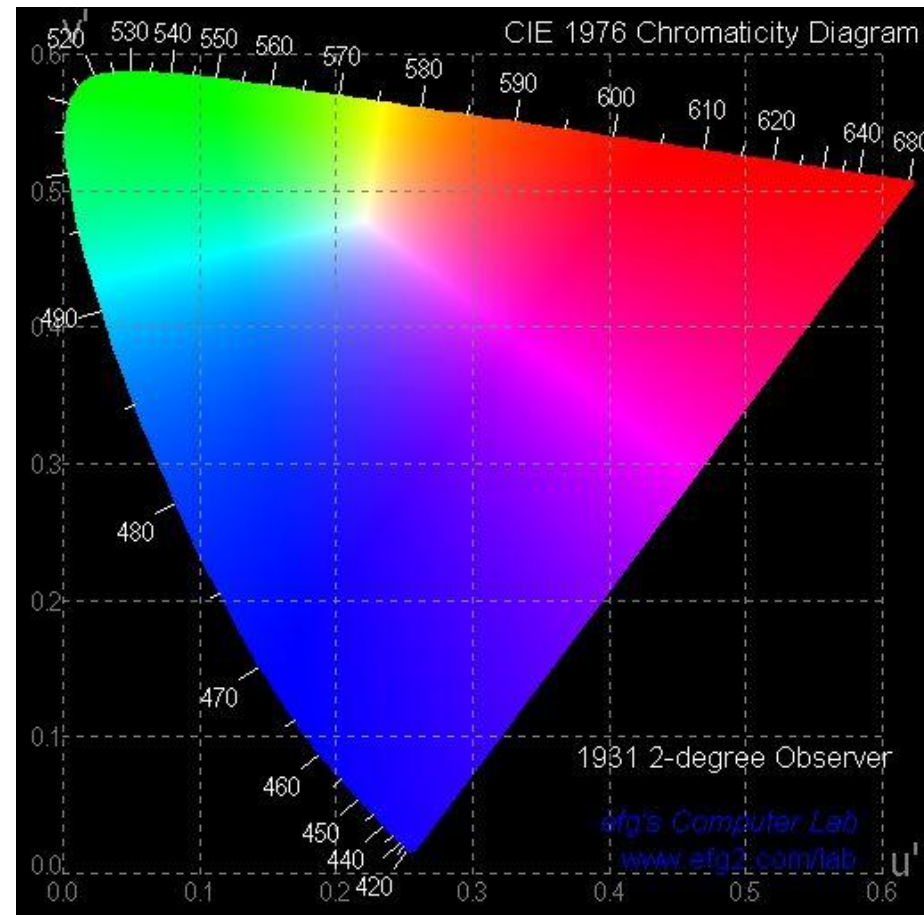

TYPES OF LEDS (1)

- Conventional LEDs

color	Wavelength (nm)	Voltage drop (V)
infrared	$760 < \lambda$	$\Delta V < 1,9$
red	$610 < \lambda < 760$	$1.63 < \Delta V < 2.03$
orange	$590 < \lambda < 610$	$2.03 < \Delta V < 2.10$
yellow	$570 < \lambda < 590$	$2.10 < \Delta V < 2.18$
green	$500 < \lambda < 570$	$2.18 < \Delta V < 4.0$
blue	$450 < \lambda < 500$	$2.48 < \Delta V < 3.7$
violet	$400 < \lambda < 450$	$2.76 < \Delta V < 4.0$
ultraviolet	$\lambda < 400$	$3.1 < \Delta V < 4.4$
white	Broad spectrum	$\Delta V = 3.5$

TYPES OF LEDS (2)

Two Types of White LEDs

- RGB systems (RGB LEDs)
 - By mixing RGB colors
 - Hard to mass produce
 - This type of LED's emission power decays exponentially with increasing temperature
- Phosphor based LEDs
 - a lower efficiency than normal LEDs
 - cheaper than a complex RGB system
 - Smaller bandwidth than RGB

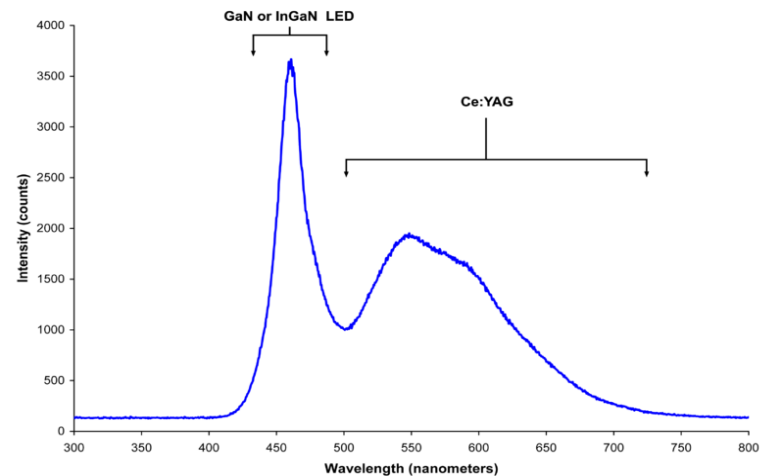
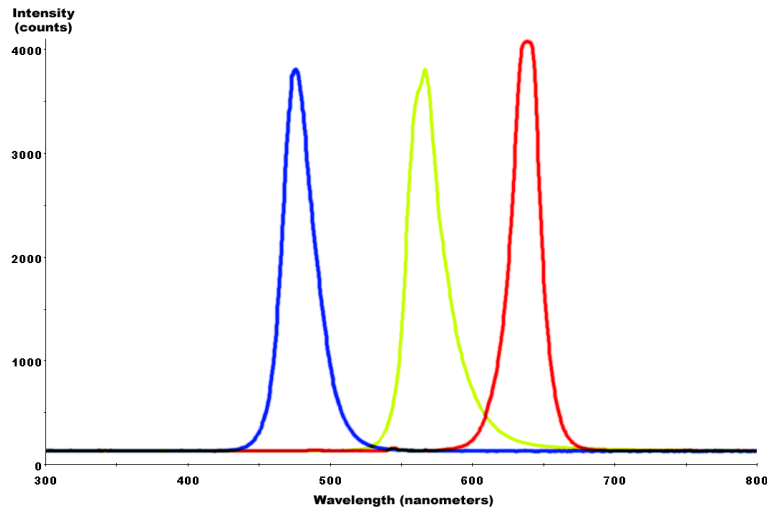

TYPES OF LEDS (3)

RGB LED & RCLED

- Spectra
 - Blue : 470 nm (peak),
30 nm (3dB BW)
 - Green : 520 nm (peak),
37 nm (3dB BW)
 - Red : 630 nm (peak),
17 nm (3dB BW)
- WDM channels possible
 - Conventional LED : 3 ~ 4 channels
 - RCLED : 30 ~ 40 channels

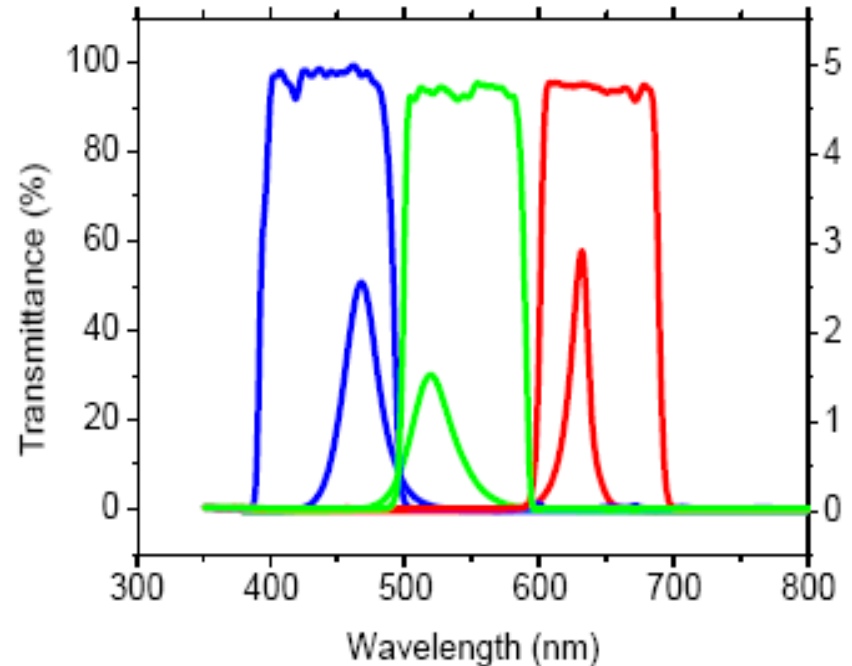

[30] Slide 15

PHOTO DETECTION DEVICES

- Various photo detecting devices
 - Photo diode
 - Better and more linear response than photoconductors
 - Photoconductor
 - Photomultiplier tube
 - Charge-coupled device (CCD): for image sensors
 - CMOS active-pixel sensor: for image sensors
- Measurement of low light intensities
 - P-N photodiodes are not used to measure extremely low light intensities. Instead, if high sensitivity is needed, avalanche photodiodes, intensified charge-coupled devices or photomultiplier tubes are used for applications such as astronomy, spectroscopy, night vision equipment and laser range finding.

PHOTO DIODE (1)

Silicon PD spectral response [2]

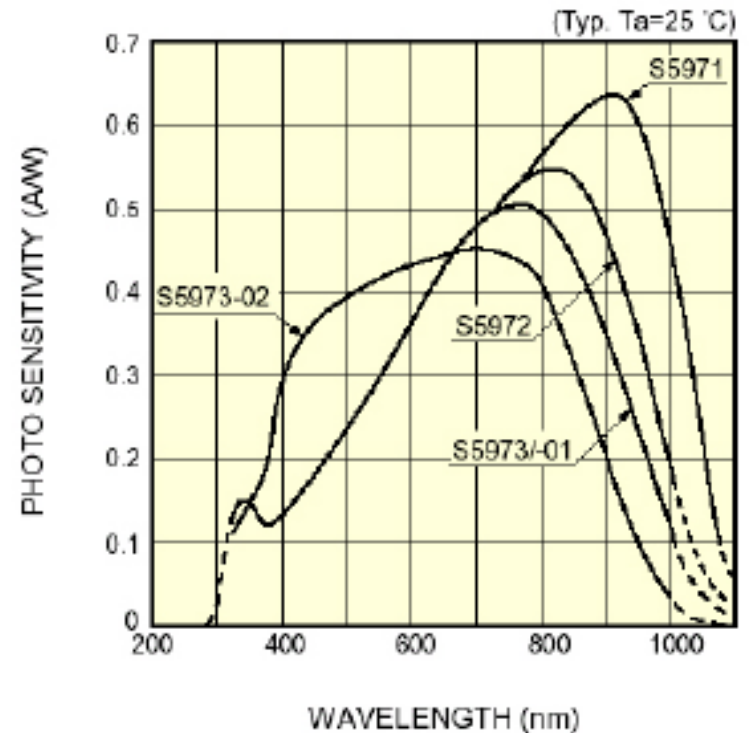
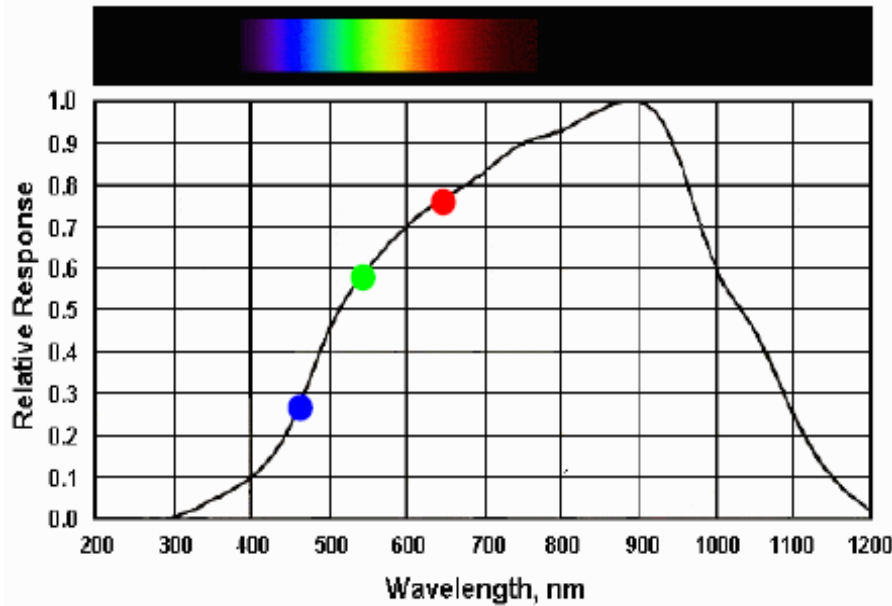

~4 dB Responsivity variation from Blue to Red

PHOTO DIODE (2)

Another Silicon PD and Avalanche PD spectral responses [4]

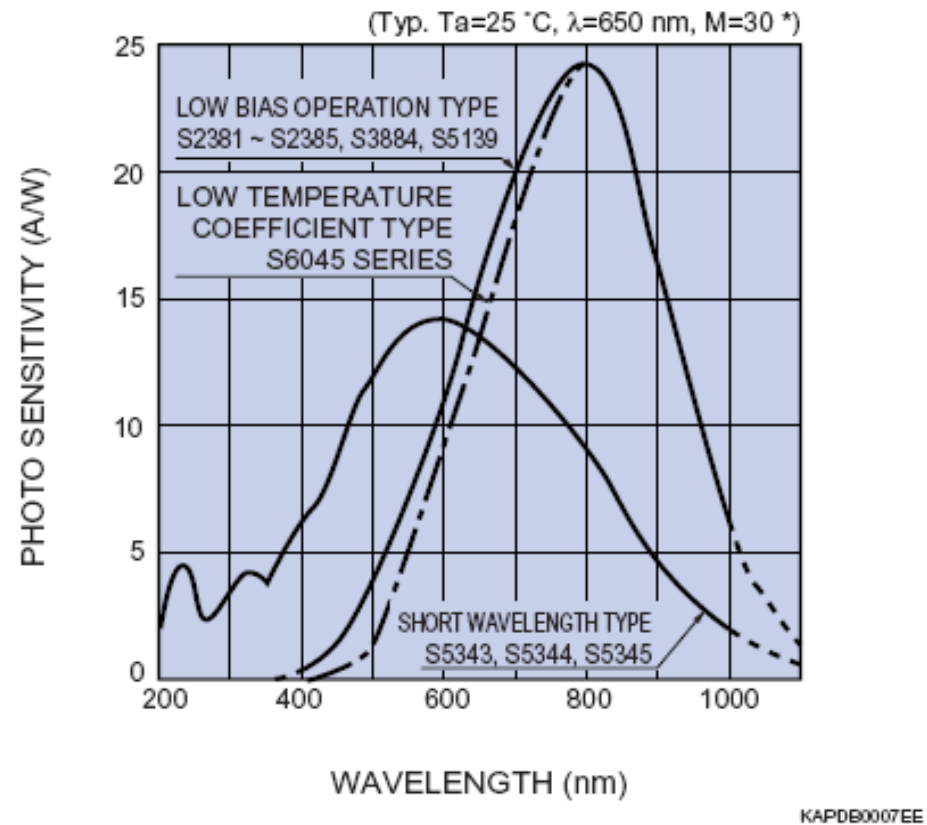
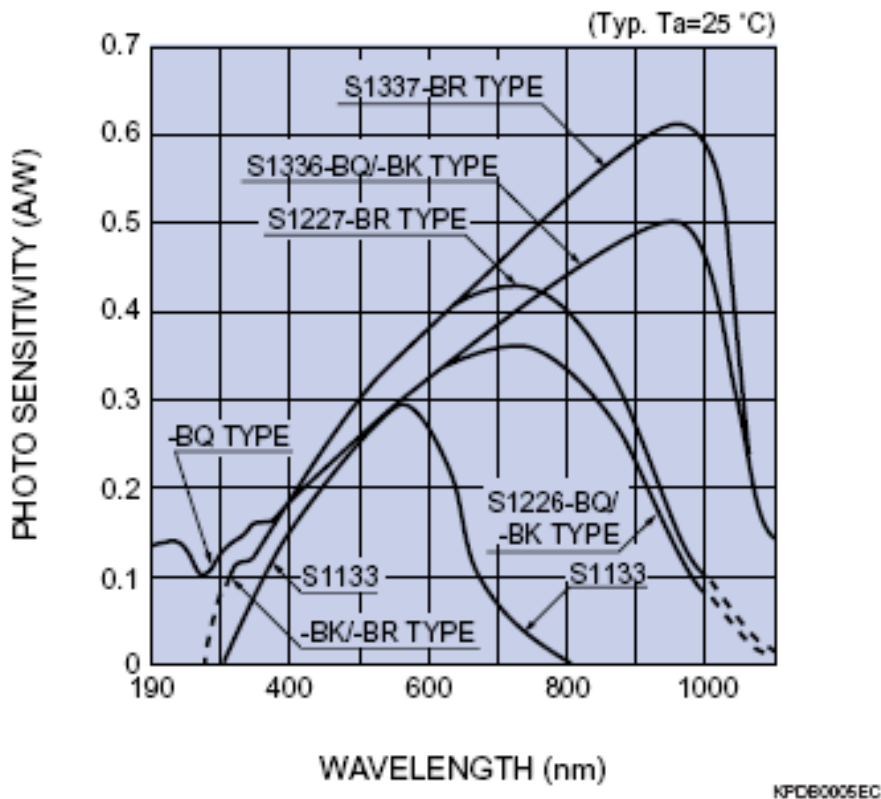

ANOTHER OPTICAL SIGNAL RECEIVER: IMAGE SENSOR *

Photo diode

- Already used for free-space optics receiver (IrDA etc.)
- Easy to receive high-speed optical signal
- **Limited space-division selectivity**
→ **Weakness for Interference light**

Image Sensor: New Technology

- Optical receiver with position detection
- Capability of interference rejection
- Low dependency for transmission distance
- Future possibility for high-speed transmission: limited by no. of frames
 - Capability of Space-Division Multiplexed data transmission

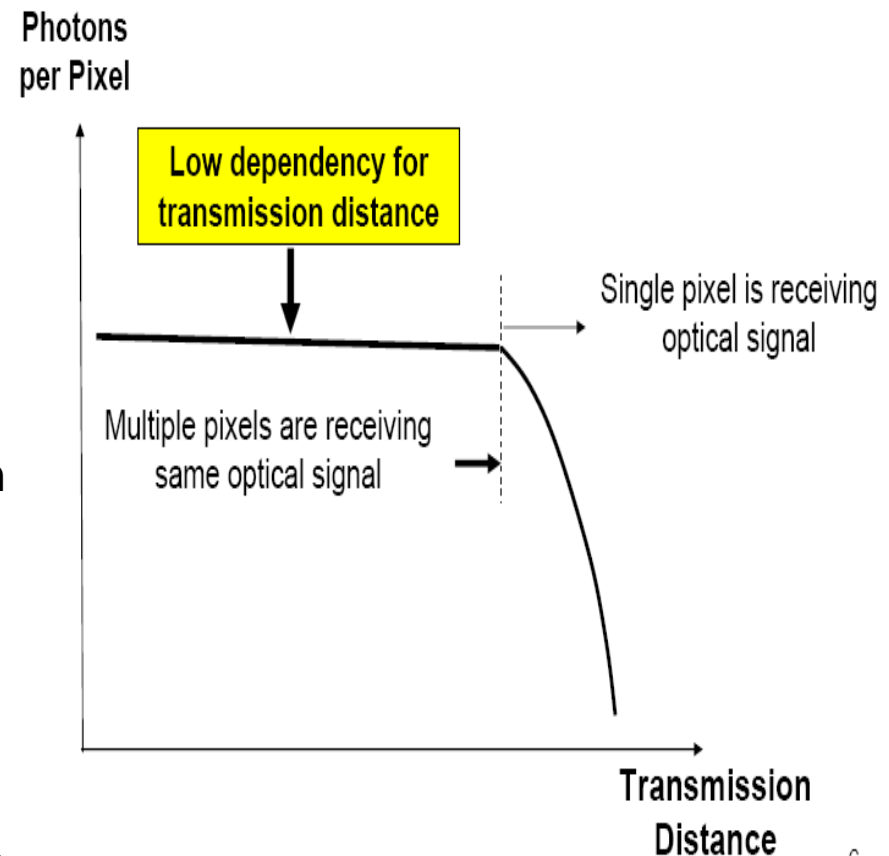

* 15-08-0652-00-0vlc-vlc-using-image-sensor

BASIC CONCEPT (1)

- Transmission and reception (or detection) of light signals
 - At the transmitter, multiple light sources (or light emitting devices) such as LEDs with different spectral distributions are used for light emission.
 - At the receiver, multiple photo detectors with different spectral responses are used for light detection.
- Any color can be represented by a point in a multi-dimensional space uniquely.
 - Any color is represented by a point in an n dimensional space – but not uniquely for most cases. It is because in general light generated by each device can also be generated by mixing light signals from other devices which have different spectral distributions.
 - Thus multi-dimensional space should be defined to represent a color with a point uniquely in this space. One possibility is use of spectrally uncorrelated light sources or photo detectors, but it is not assumed in this document.
 - A unique color for a point in the space can be generated by mixing lights emitted from n light emitting devices and be detected by processing light signals detected by k photo detectors.

BASIC CONCEPT (2)

Light Signal Delivery Model from Transmitter to Receiver

- Radiation at Transmitter
 - Multiple light emitting devices emit light signals at transmitter. Each device has its own spectral distribution, $S(\lambda)$, which determines its emitted power by calculating total power throughout the whole wavelength range. By using the color matching functions of a light space and by calculating stimulus values – for two dimensional space, X , Y and Z values - of the light space, the color of emitted light perceivable by human eyes can be determined.
- Perception by Human Eyes
 - To know how human eyes react to emitted light, emitted light signal which has spectral distribution, $S(\lambda)$, is multiplied by a standardized luminosity function - wavelength-weighted by the luminosity function to correlate with human brightness perception. Then total power perceived by human eyes can be determined.
- Detection at Receiver
 - The emitted signal has spectral distribution, $S(\lambda)$, which is delivered to the detector which is characterized by its responsivity, its own spectral sensitivity, which determines the spectral characteristics and total received power to determine color detected.

BASIC CONCEPT (3)

Light Signal Delivery Model from Transmitter to Receiver

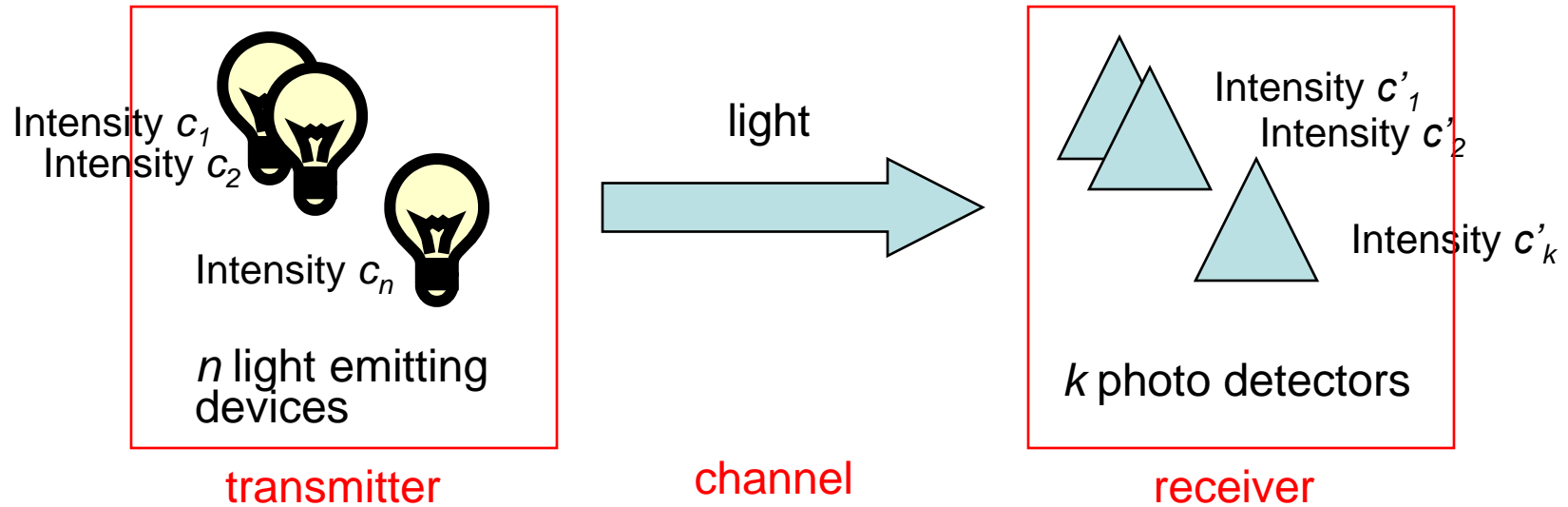

$$C_{total} = c_1 + c_2 + \dots + c_n$$

where $c_i = c_i \int s_i(\lambda) d\lambda$

$$C'_{total} = c'_1 + c'_2 + \dots + c'_k$$

where $c'_i = c'_i \int s'_i(\lambda) d\lambda$

Transmitted light power: $\sum c_i \int s_i(\lambda) d\lambda$	+	noise interference	=	Received light power: $\sum c'_i \int s'_i(\lambda) d\lambda$
---	---	--------------------	---	--

- In this modulation, this property is applied.

MODULATION BLOCKS REVISITED

- Transmitter

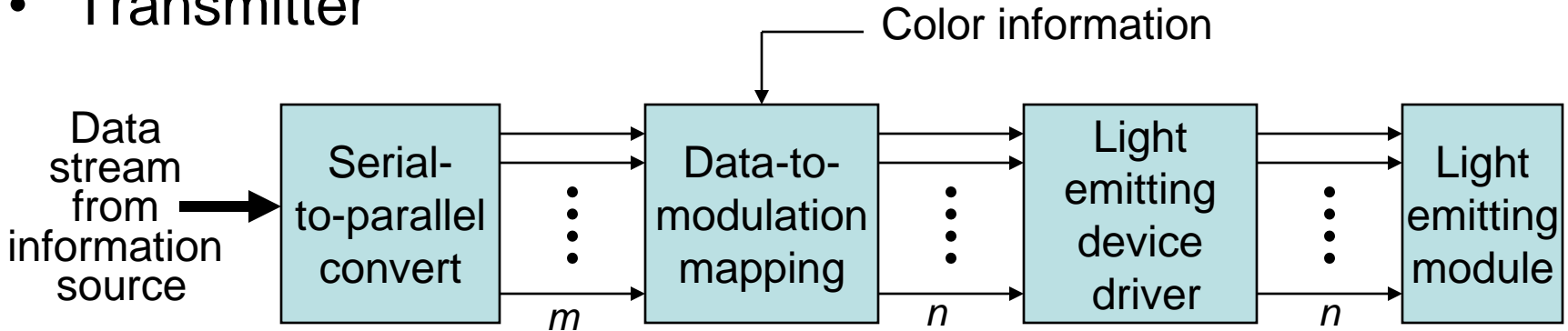

- Receiver

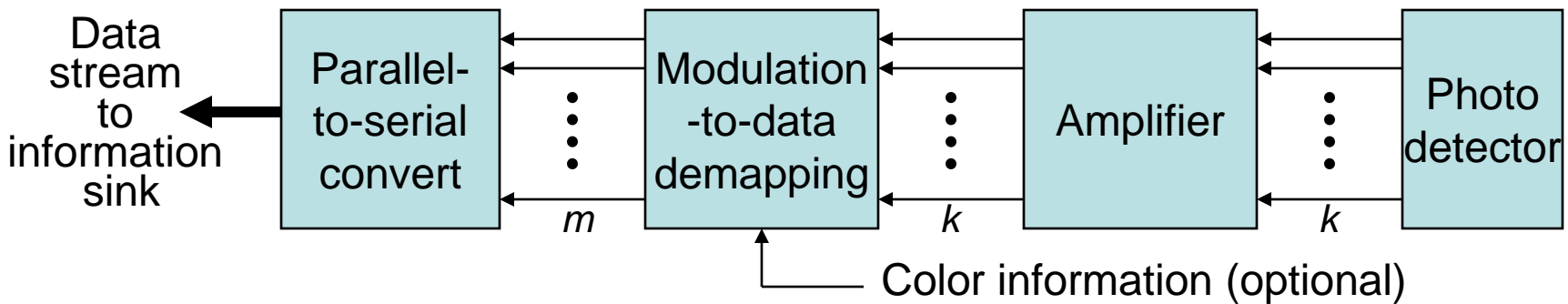

KEY PART FOR MWIM: MAPPING

Data-to-modulation mapping (transmitter)

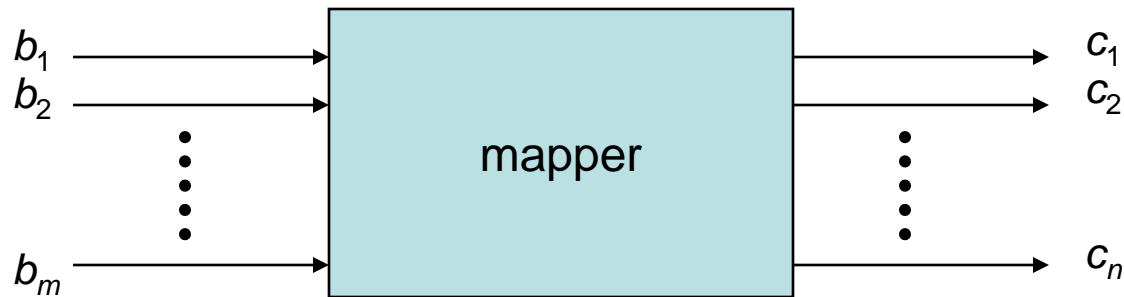

Modulation-to-data demapping (receiver)

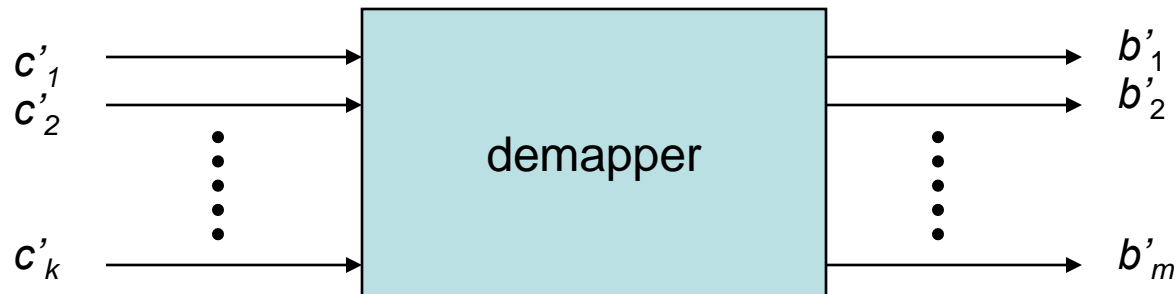

GENERATION OF CONSTELLATION (1)

- Assumptions
 - Equi-probable data elements
 - For a fixed number of symbols' duration, color is not changed.
- Input
 - Information data: m bits $\rightarrow 2^m$ symbol elements $\rightarrow 2^m$ points
 - Color information: (x_c, y_c)
- Output
 - Constellation: (x, y)
- Two parameters considered to pick points in a light space
 - Colors perceptible by human eyes
 - Equi-distance between two adjacent points when points are detected by photo detectors

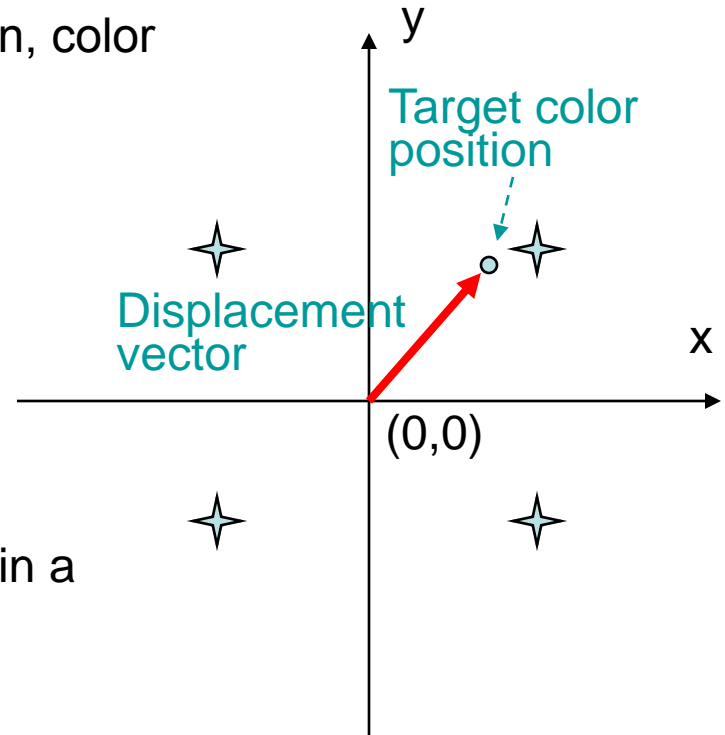

GENERATION OF CONSTELLATION (2)

- Maximum area of constellation is determined by two factors:
 - Point of target color for human eyes: this point becomes the origin of constellation.
 - Gamut formed by primary color points which represent points of light emitting devices used.
- Maximum constellation area determined

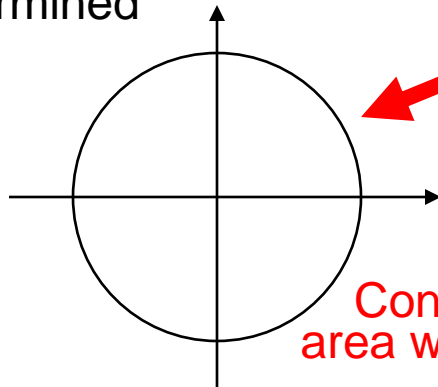

Constellation area with radius r_c

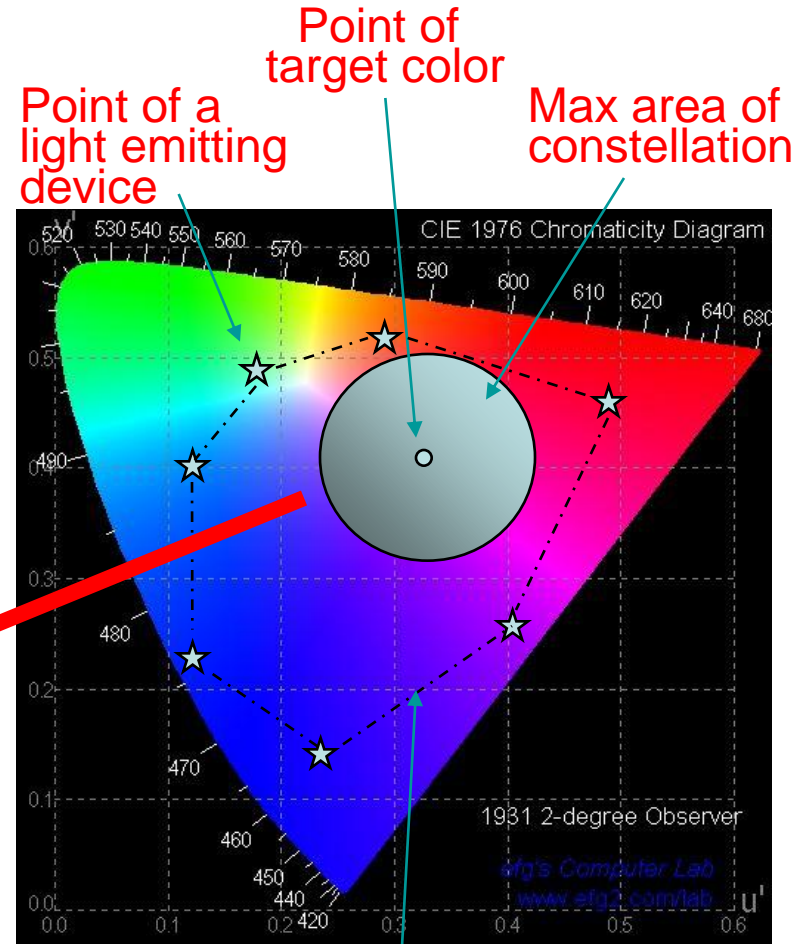

Gamut formed by seven light emitting devices

GENERATION OF CONSTELLATION (3)

Normalized constellation

Inside a unit circle centered at the original, 2^m points are assigned so that the minimum distance between any two points be maximized.

Examples of constellation

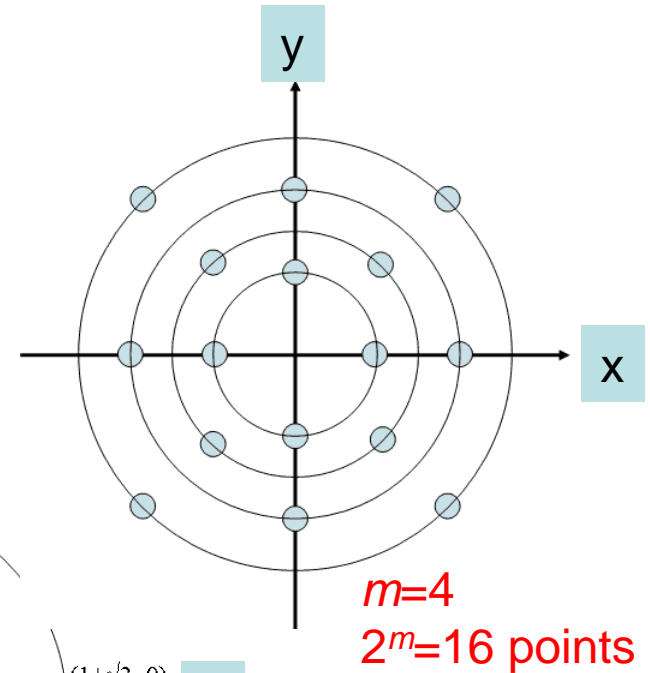
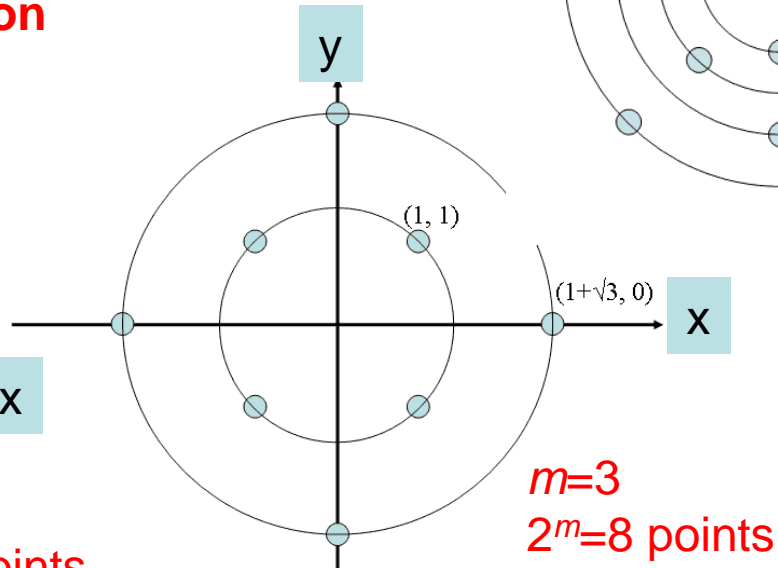
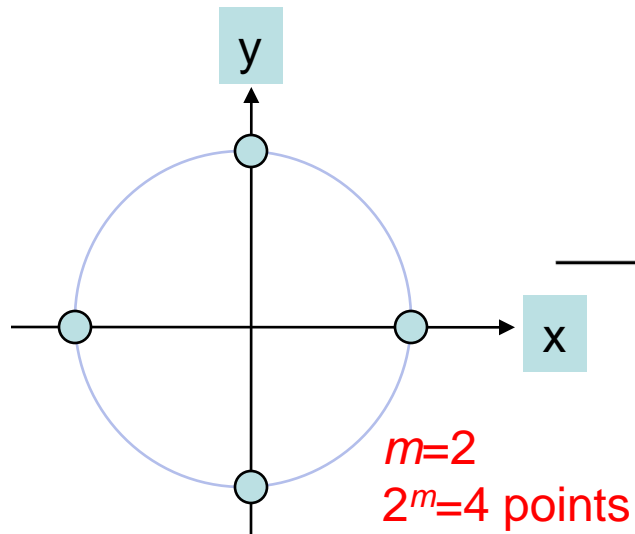

GENERATION OF CONSTELLATION (4)

Constellation scaled with the center of target color location

Normalized constellation generated is shifted so that the center is located at the target color point and scaled so that constellation area fits the maximum area with a radius of r_c .

Examples of constellation

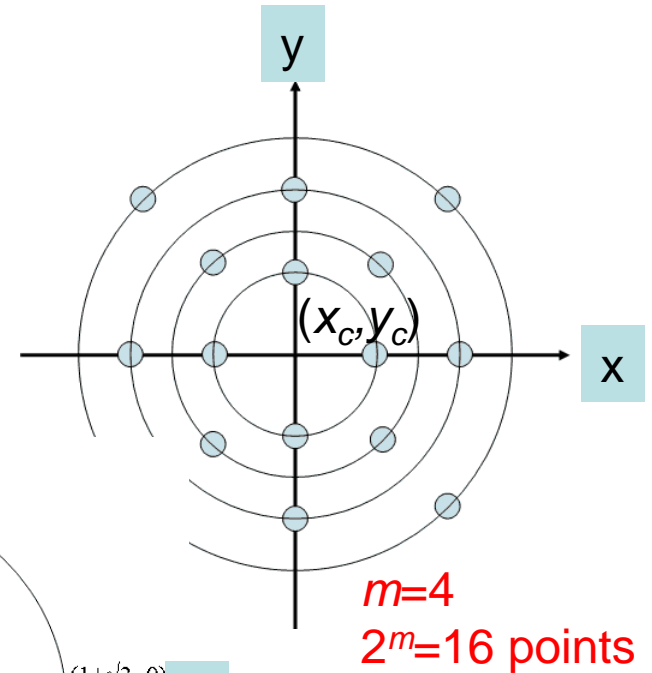
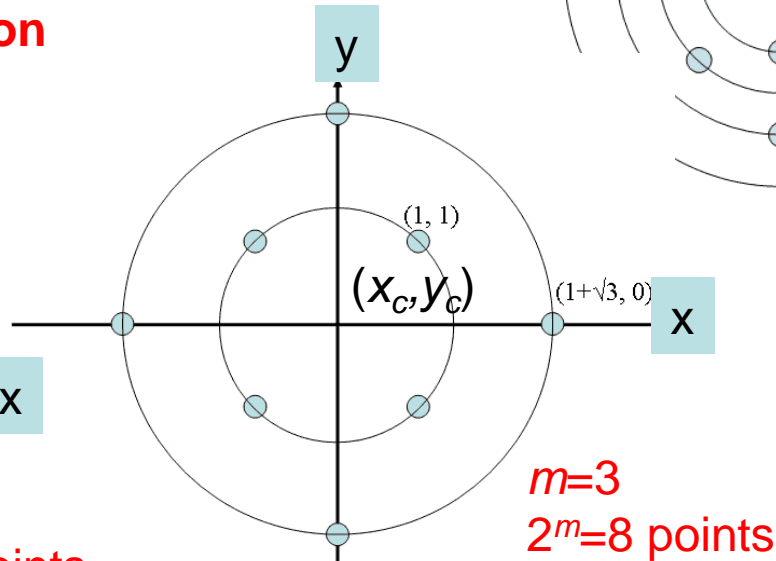
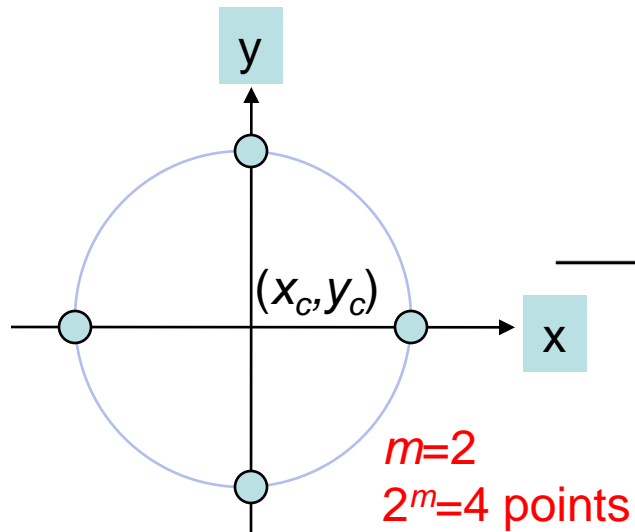

CONSTELLATION TO (c_1, c_2, \dots, c_n) MAPPING

- Assumption
 - Perceptual uniformity or linearity of light emitting devices and photo detectors in the light space
- Input/output
 - Input: Constellation: (x, y)
 - Output: (c_1, c_2, \dots, c_n)
- Two cases for color properties of light emitting devices
 1. Using $(x_i, y_i) \ i=1, 2, \dots, n$ for all light emitting devices if $(x_i, y_i) \ i=1, 2, \dots, n$, is given
 2. Using spectral distributions of light emitting devices if $(x_i, y_i) \ i=1, 2, \dots, n$, is not given

$(c'_1, c'_2, \dots, c'_k)$ TO CONSTELLATION DEMAPPING

- Assumption
 - Uniformity or linearity of light emitting devices and photo detectors in the light space
 - The receiver has constellation information that the transmitter applies and can get color information for each symbol received for itself or from outside.
- Input/output
 - Input: $(c'_1, c'_2, \dots, c'_n)$: light intensities measured by photo detectors: **noise added from channels to these coefficients**
 - Output: information point, (x', y') , in a constellation most closely matching to a set of light intensities, $(c'_1, c'_2, \dots, c'_n)$
- Two cases for color detection properties of photo detectors
 1. Using (x'_i, y'_i) $i=1, 2, \dots, k$ for all photo detectors if these values are given
 2. Using spectral distributions of photo detectors if (x'_i, y'_i) , $i=1, 2, \dots, k$, is not given

COLOR INFORMATION FROM CONSTELLATION

How to extract color information at receiver?

Two cases

1. Transmitter sends color information (x_c, y_c) : TV signals, etc.
2. Using a fixed number of previous received symbols, color information can be extracted:

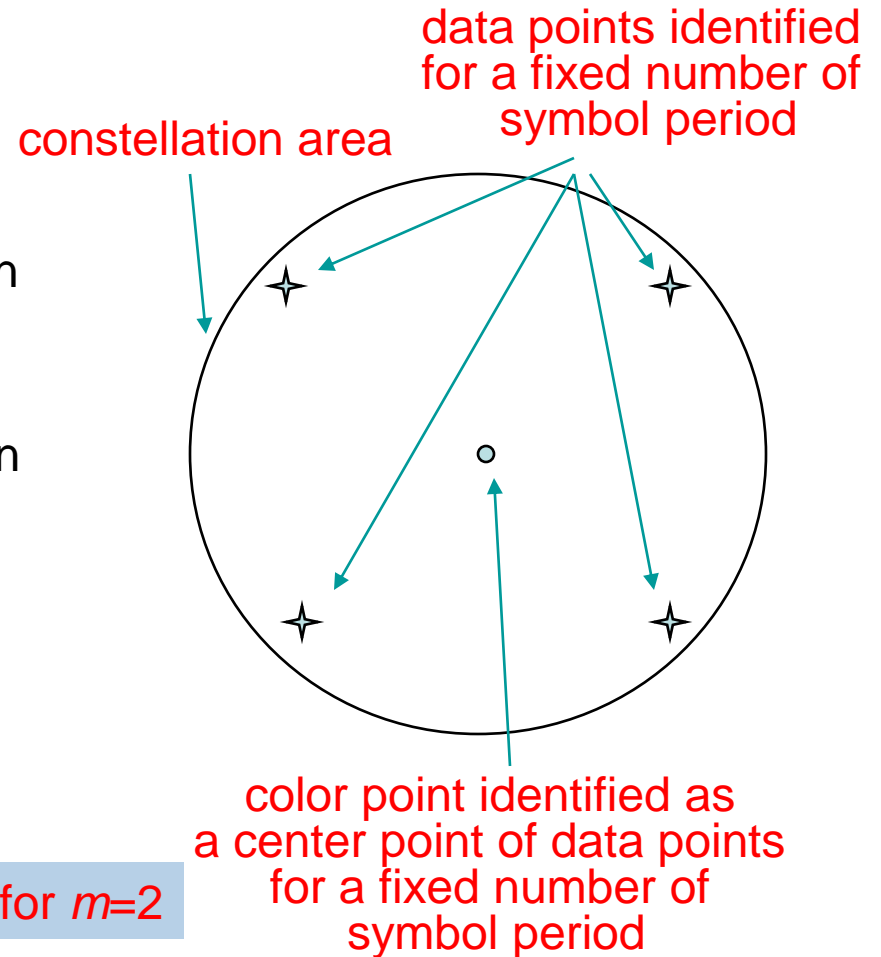

For an example for $m=2$

GENERATION OF TARGET COLOR OF EACH BAND USING MULTIPLE LEDS

- Basic concept
 - If there are multiple subbands in a whole band, each subband can not be represented by a single LED: multiple LEDs should be used.
 - If 8 bands exist, eight different LEDs can be used by assigning an LED for each band. This is not a usual and most efficient case. The best way is that by using a fixed number of LEDs all bands can be covered. It can be realized using a target color generation method applied in this New Modulation.

INFORMATION DATA FROM CONSTELLATION (1)

With an assumption that

- Gamut formed by photo detectors should include all area of gamut formed by light emitting devices at transmitter. If not, some distortion is inevitable.

How to extract constellation scaling factor for a color at receiver?

How to get constellation area at receiver?

Some cases can be considered:

1. Periodically transmitter broadcasts information on light emitting devices used.
2. Whenever color changes or periodically with a fixed interval, transmitter broadcasts scaling factor information with color information.
3. Without any information above, the receiver can know color information and constellation by examining points of a fixed number of previously received symbols.

INFORMATION DATA FROM CONSTELLATION (2)

Case that target color information delivered from transmitter (Case 1)

Extraction of information data from received signals

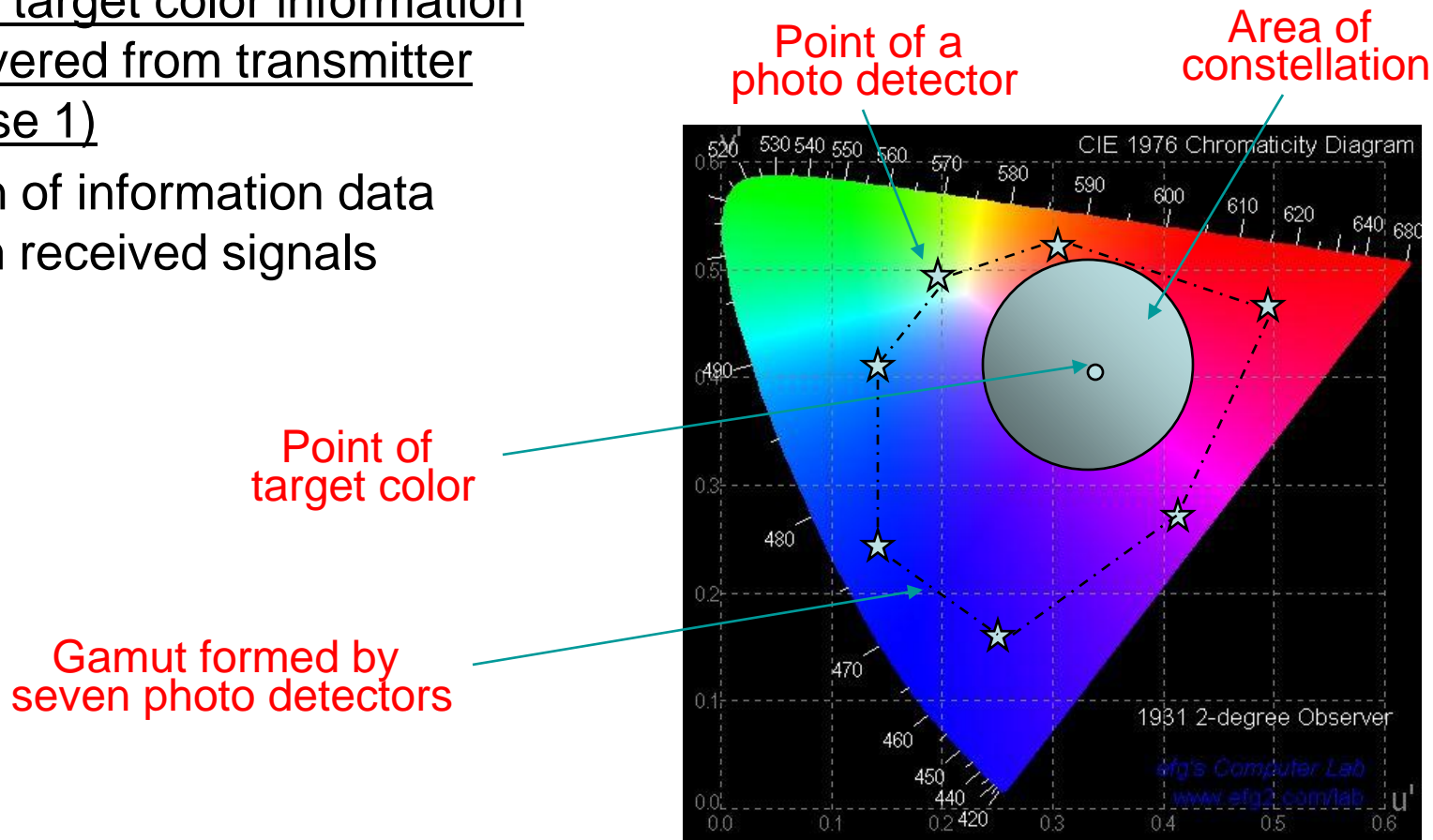

WHY NEW MODULATION ?

MOTIVATION TO NM (1)

- Not affected by light intensity: **not intensity modulation**
 - Only related to positions of signals in a light space
 - **Dimming control is not a problem to implement.**
- Any colors can be generated: independent of colors
 - Free from colors of lights to be sent: independent of colors of light signals
 - Any target colors generated for human eyes; signals detected by PDs
- **Progressive modulation** can be achieved without any serious burden
 - Lower to higher data rates can be achieved with a common constellation (scheme) corresponding to various applications
 - Varying number of points in a constellation and symbol periods
 - Lowest data rate for remote controlling: 2-NM, 1 symbol/4 symbol periods → 1/4 bit/symbol period → 40 Mbps
 - Highest data rate for file transfer: 64-NM, 1 symbol/1 period → 6 bits/symbol period → 1 Gbps

WHY NEW MODULATION ?

MOTIVATION TO NM (2)

- Adaptive to various data rates and colors
- Colors of light sources: adaptive to various colors

Application category	colors
Traffic light – vehicle	red, green and amber
Vehicle– vehicle	can be determined in favor of modulation scheme applied
Infra- vehicle (outdoor)	can be determined in favor of modulation scheme applied
Infra-mobile (indoor low speed)	can be determined in favor of modulation scheme applied
Infra-mobile (indoor high speed)	white/illumination
Mobile/fixed-mobile	can be determined in favor of modulation scheme applied

WHY NEW MODULATION ?

MOTIVATION TO NM (3)

- With peak transmit power fixed,
 - Higher average transmit power
 - Longer range
 - Lower BERare more desirable.
- New Modulation (NM),
 - should not depend on the color transmitted
 - **Self identification of colors of light signals detected**
 - should not depend on the intensity of transmitted signals
 - Not intensity modulation, but constellation modulation in a color space: each point (or symbol) represented by two coordinates in a color space
 - Use full power for data representation: more power can be used for transmission for the case of confined peak power.

WHY NEW MODULATION ?

MOTIVATION TO NM (3)

- Implementation issues for transmitters and receivers
 - One light transmitter consists of more than 2 light emitting devices.
 - If it is not the case, another modulation scheme should be used.
 - If existing light sources with one light emitting device is used,
- **Simple implementation**
 - **At the transmitter**
 - **Given x and y coordinates or spectral distributions of n light emitting devices in a light space used for the light sources by manufacturers**
 - **A look-up table applied for data to intensities mapping for 2^m NM**
 - **At the receiver**
 - **Given x and y coordinates or spectral responses of k photo detection devices in a light space used for the light sources by manufacturers**
 - **A simple formula applied for intensities to data demapping for 2^m NM**

EXPERIMENT METHODS BASED ON TRANSMIT POWER

- Fixed average power method *
 - Modulation methods can be evaluated under a fixed average power.
 - A fundamental limit for energy conservation and to impose a bound on the current that LED can consume per unit time.
 - The LED has the same luminosity.
- Fixed peak power method *
 - This is important because LED has a peak power limit.
 - Maximum current of existing LEDs is strictly regulated. The peak current indicates magnitude of load on the LED. The same peak power imposes the same burden to LEDs which entails equal amplitude.

* Sugiyama, H., Haruyama, S., and Nakagawa, M., Experimental Investigation of Modulation Method for Visible Light Communications, IEICE Trans. on Communications, Vol E-89B, No. 12, Dec., 2006

EXPERIMENT CONDITION, INDOOR

- Experiment condition *

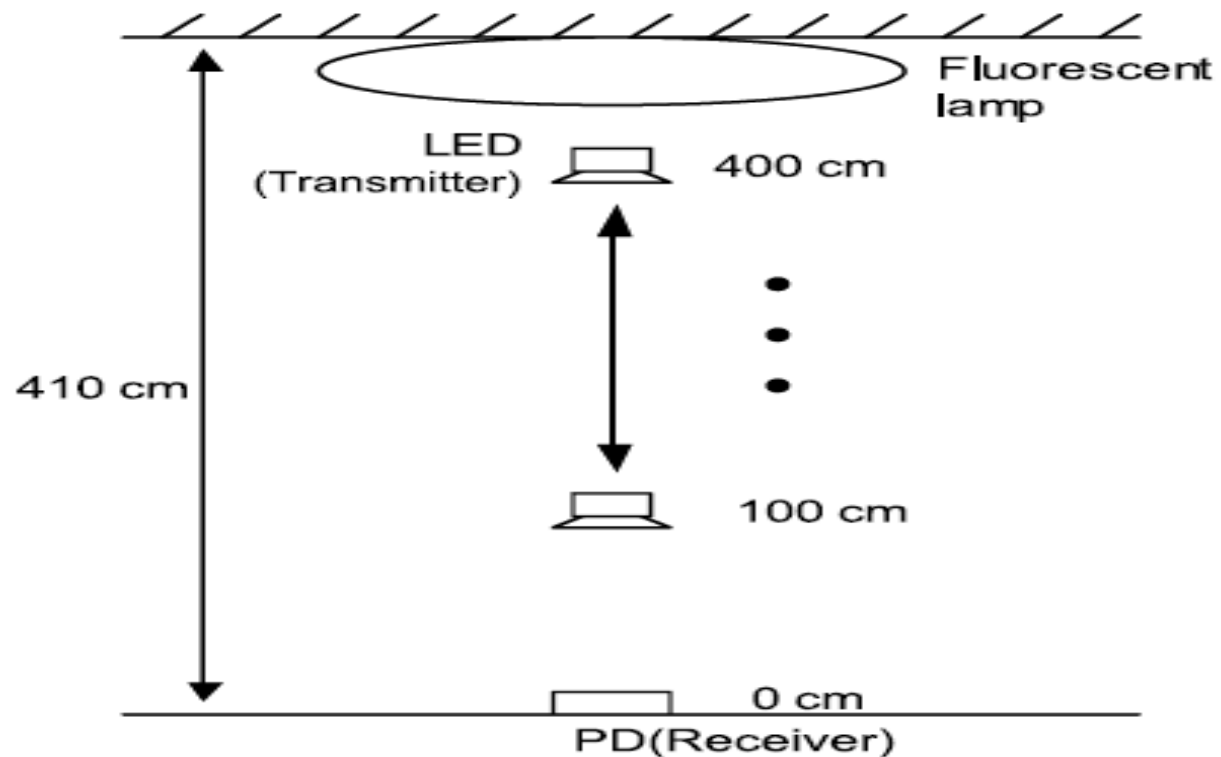

* Sugiyama, H., Haruyama, S., and Nakagawa, M., Experimental Investigation of Modulation Method for Visible Light Communications, IEICE Trans. on Communications, Vol E-89B, No. 12, Dec., 2006

EXPERIMENT CONDITION, OUTDOOR

- Experiment condition*
 - Height of the traffic light: 6 m
 - Stop line at the intersection: 20 m
 - Lane width: 3.5 m
- Intersection
 - Limited to two-lane road in each direction
 - Setting parameters following traffic standards in South Korea
 - Traffic light (4 types) : red, yellow, turning-left and green
 - Measurements of roadways, street crossings

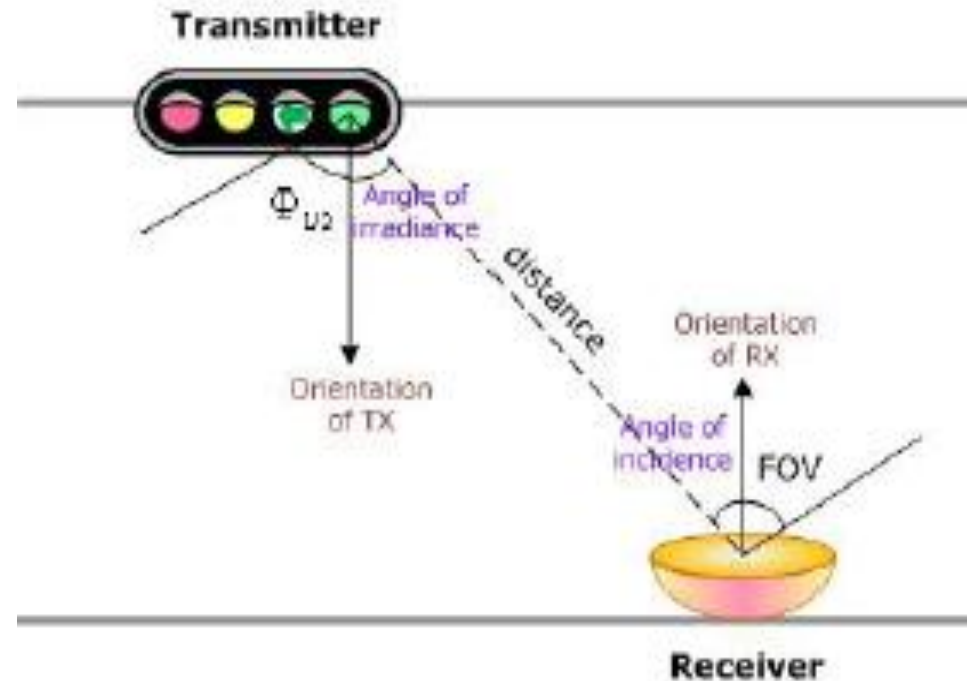

* 15-09-0052-01-0007-simulation-of-vlc-between-the-traffic-light-and-vehicles

EXPERIMENT CONDITION, OUTDOOR

- Channel model*
 - Line-of-Sight (LOS) case
 - No inter symbol interference (ISI) effect due to no multipath
 - Generally ISI is a major impediment for reliable communication
 - If the environment with locating buildings in a distance from the intersection is assumed, we can make the problem simply with only LOS path without multipaths because of negligible multipath effect at the intersection.

- Received optical power (P_r)

$$P_r = H(0) P_t$$

where P_t : transmit optical power

$H(0)$: channel gain

- Transmitter/receiver

- Transmitter : LEDs at traffic light
- Receiver (PD) positions
 1. Center of front bumper
 2. Top of windshield
 3. Both side mirrors (left, right)

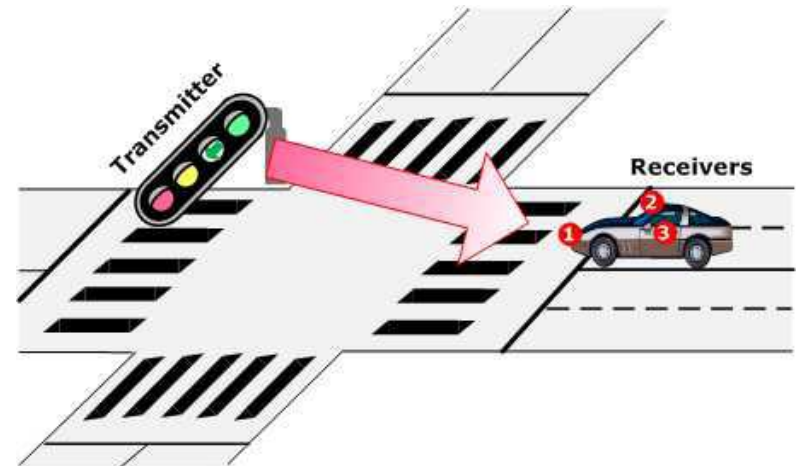

* 15-09-0052-01-0007-simulation-of-vlc-between-the-traffic-light-and-vehicles

PERFORMANCE ANALYSIS, OUTDOOR

- BER performance for OOK modulation
 - Most efficient for binary modulation schemes in view of power, bandwidth and pulse shaping, etc.
$$BER = Q(\sqrt{S/N})$$

S : signal power
 N : noise power
- Target requirements
 - Target data rate : 10kbps ~ 100kbps
 - BER for stable communication link : 10^{-6}
- Minimum SNR for OOK modulation = 13.6 [dB]

* 15-09-0052-01-0007-simulation-of-vlc-between-the-traffic-light-and-vehicles

SIMULATION RESULTS (1)

- Primary factors of change
 - Required data rate is enough to guarantee a favorable communication link.
 - Performance depends on the receiver's position and orientation.
 - Simulation results show that any receiver of all recommended positions can reliably communicate with required data rate, less than 100kbps.

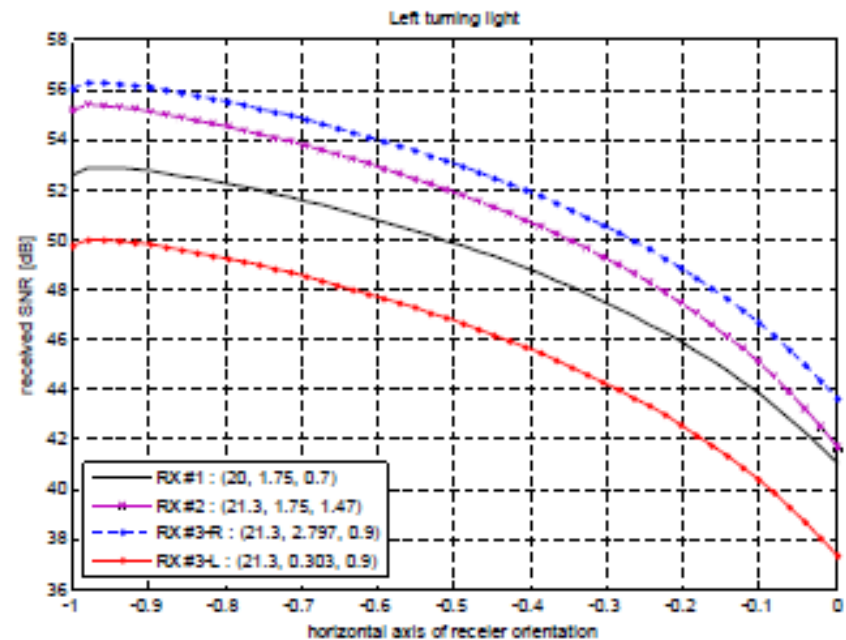
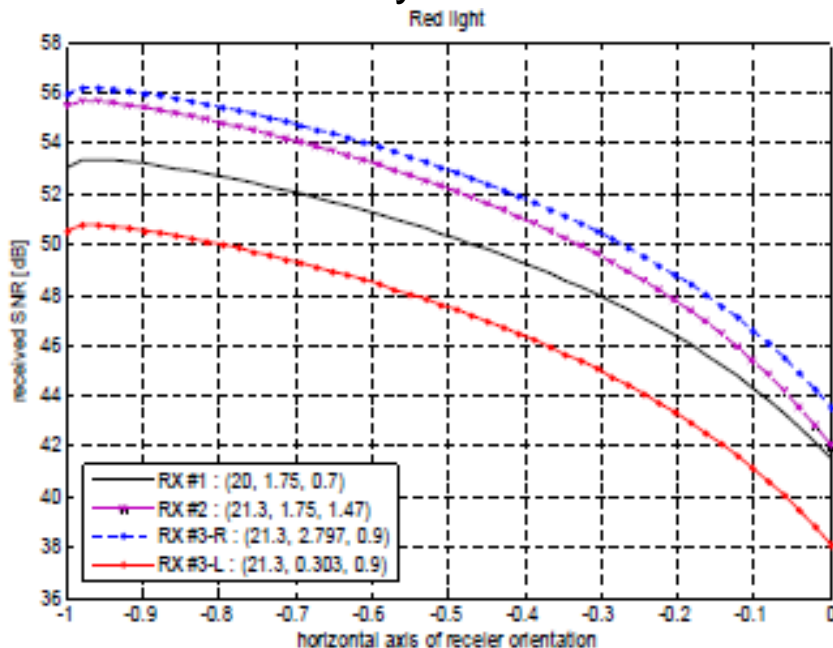

PROPOSED MODULATION SCHEMES

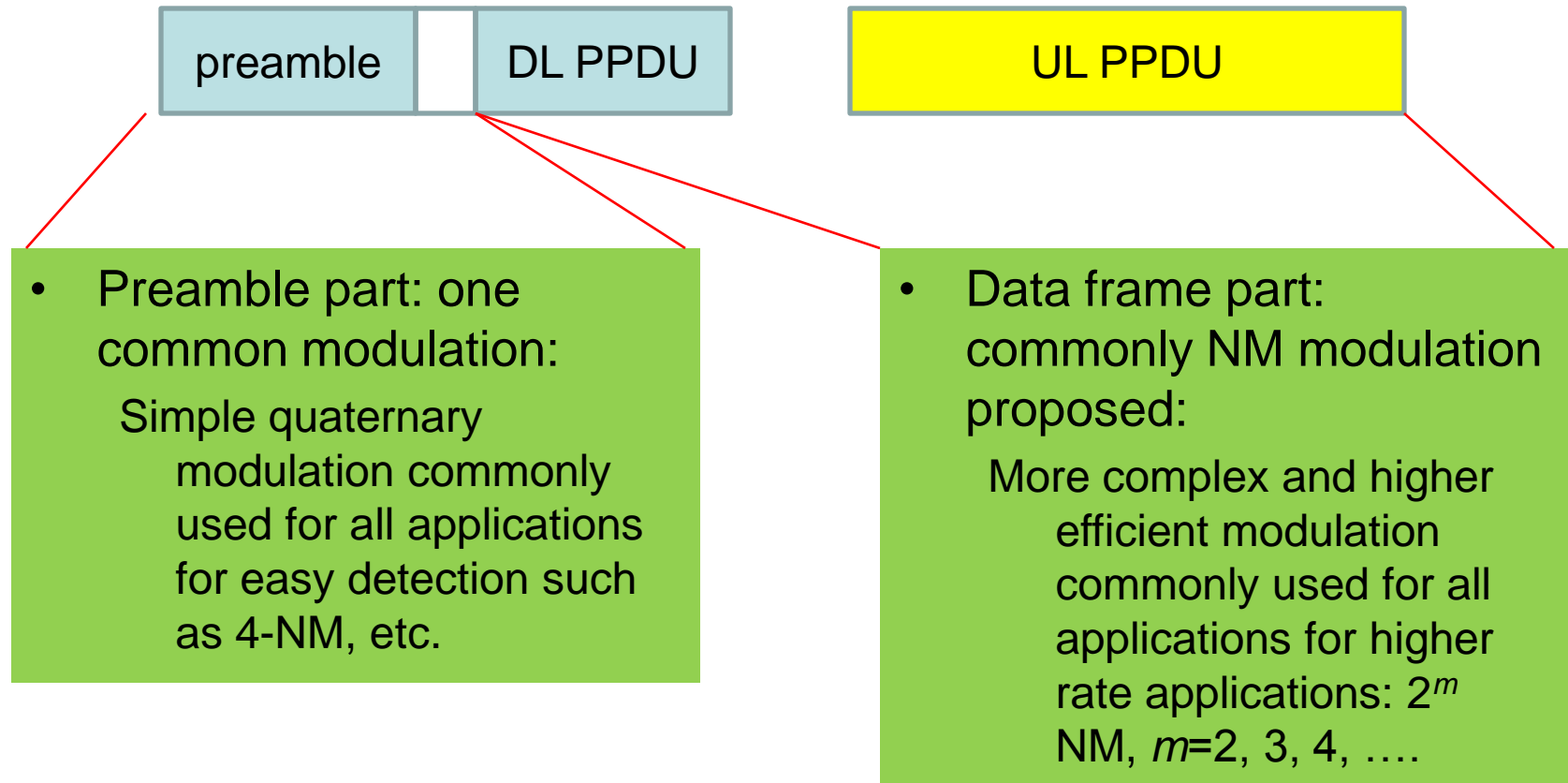

DUPLEX/MULTIPLEX /MULTIPLE ACCESS

VARIOUS DUPLEXES POSSIBLE

- Conventional duplex schemes for full duplex
 - TDD (Time Division Duplex)
 - FDD (Frequency Division Duplex)
- A couple of duplex schemes for VLC
 - Duplex 1: Using OFDM/OFDMA assumed
 - A subset of frequency components for downlink
 - Another subset of frequency components for uplink
 - Duplex 2: Direction Division Duplex (DDD)
 - Using directional LEDs
 - Duplex 3: Code Division Duplex (CDD)
 - Using orthogonal PN sequences

* 15-08-0790-01-0vlc-Technical-Issues-on-VLC

VARIOUS DUPLEX CANDIDATES (1)

- Duplex 1: Orthogonal Frequency Division Duplex (OFDD)
 - If MUX/MA required: Using OFDM/OFDMA assumed
 - A subset of frequency components for downlink to a single device or multiple devices
 - Another subset of frequency components for uplink

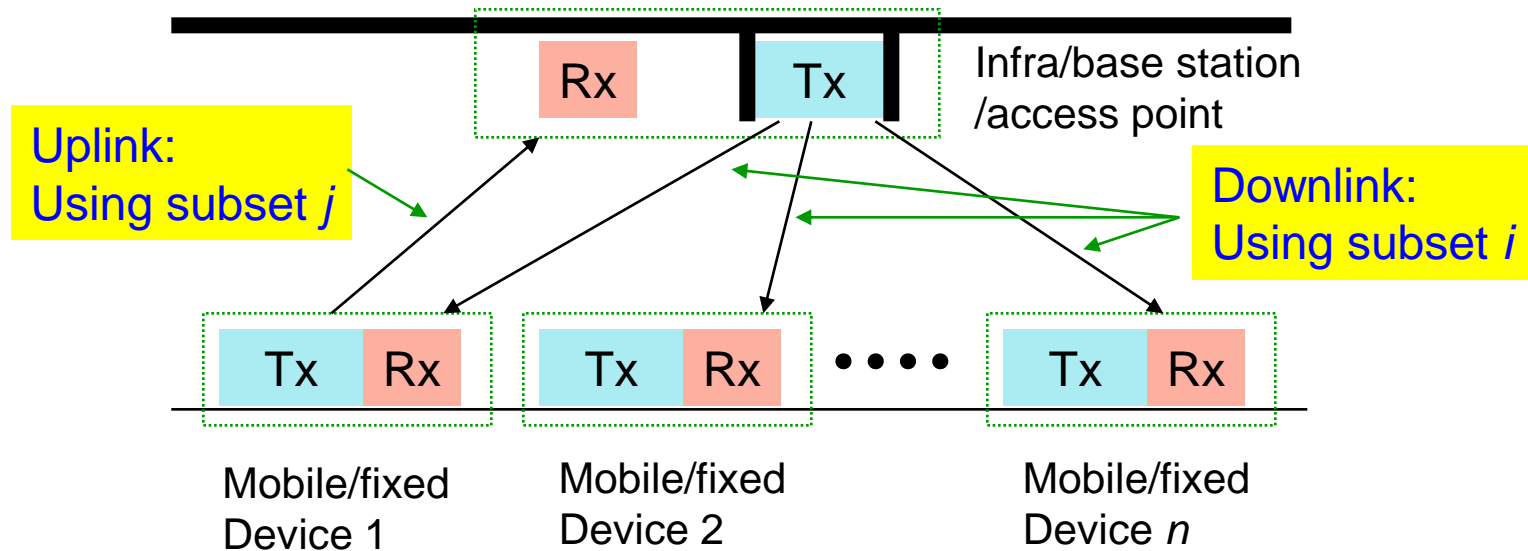

* 15-08-0790-01-0vlc-Technical-Issues-on-VLC

VARIOUS DUPLEX CANDIDATES (2)

- Duplex 2: (Direction Division Duplex, DDD)
 - Duplex: using isolation between uplink and downlink through directivity of transmitter and receiver LEDs

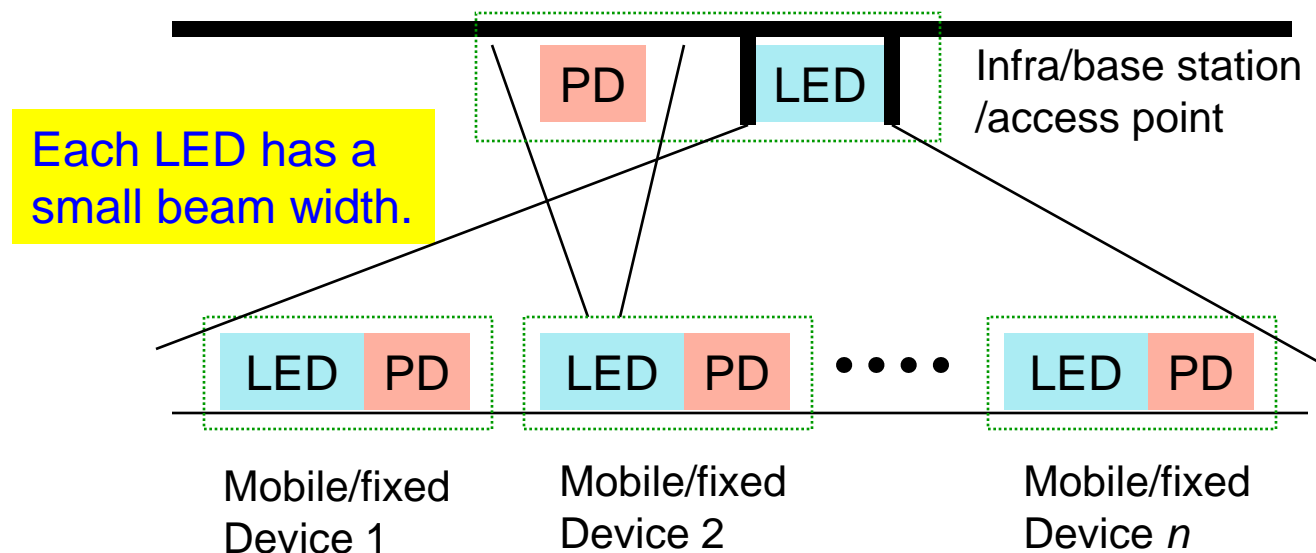

* 15-08-0790-01-0vlc-Technical-Issues-on-VLC

VARIOUS DUPLEX CANDIDATES (3)

- Duplex 2: (Direction Division Duplex, DDD) (cont'd)
 - For downlink, a broad beam is used to broadcast light signals while for uplink a narrower (pencil) beam is used to dedicate the signal to a specific receiver of a base station (or access point or infra).

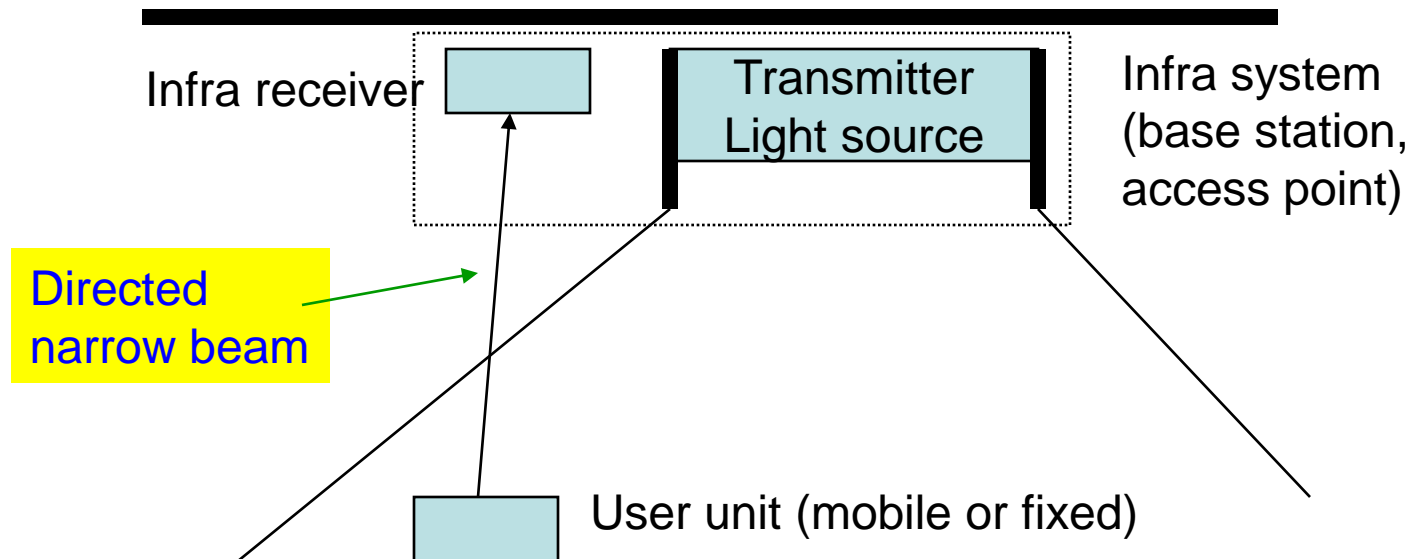

* 15-08-0790-01-0vlc-Technical-Issues-on-VLC

VARIOUS DUPLEX CANDIDATES (4)

- Duplex 3: Code Division Duplex (CDD)
 - For downlink and uplink, different orthogonal PN sequences are assigned.
 - For downlink: PN sequence i
 - For uplink: PN sequence j for User Unit j
 - With this scheme, multiplexing and multiple access can also be achieved.

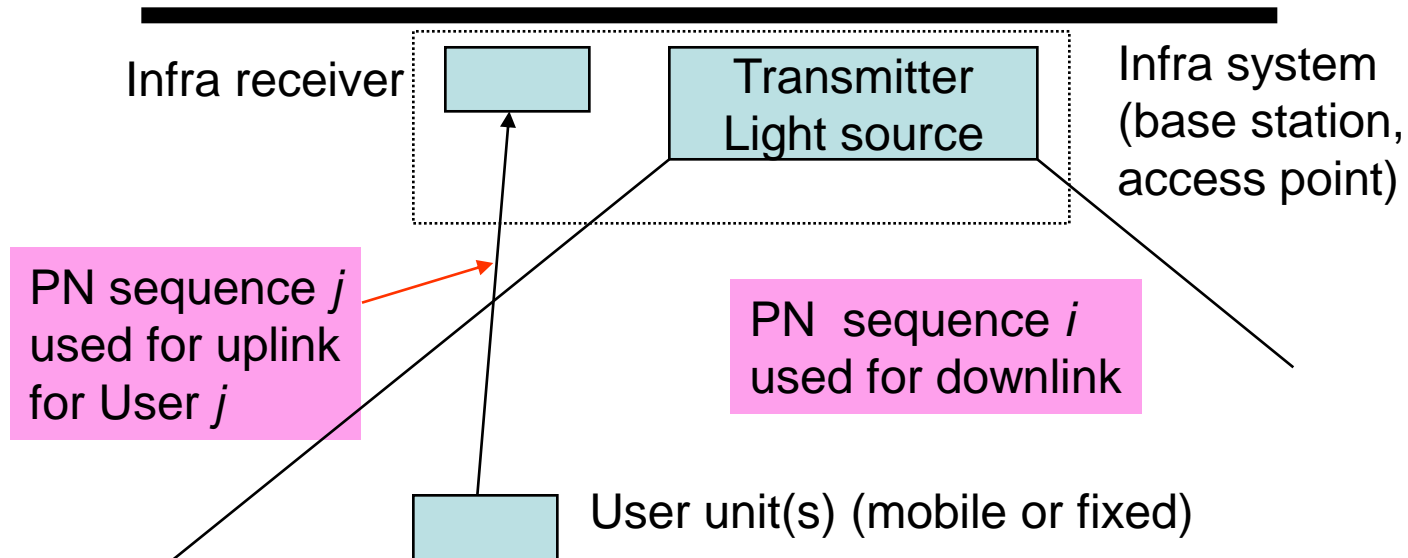

VARIOUS DUPLEX CANDIDATES (5)

- Code Division Duplex (CDD) proposed in this document
 - Using two 8-bit orthogonal Walsh codes → 16 bit orthogonal code
 - $8 \times 8 = 64$ combinations: up to 64 users can communicate simultaneously.
 - Full duplex mode
 - Provide full flexibility in uplink/downlink balancing
 - Symmetric/asymmetric
 - More time efficient than TDD and more spectrally efficient than FDD
 - Autocorrelation and cross correlation should be checked.

VARIOUS DUPLEX CANDIDATES (6)

- Auto-correlations of sequences for Code Division Duplex (CDD)

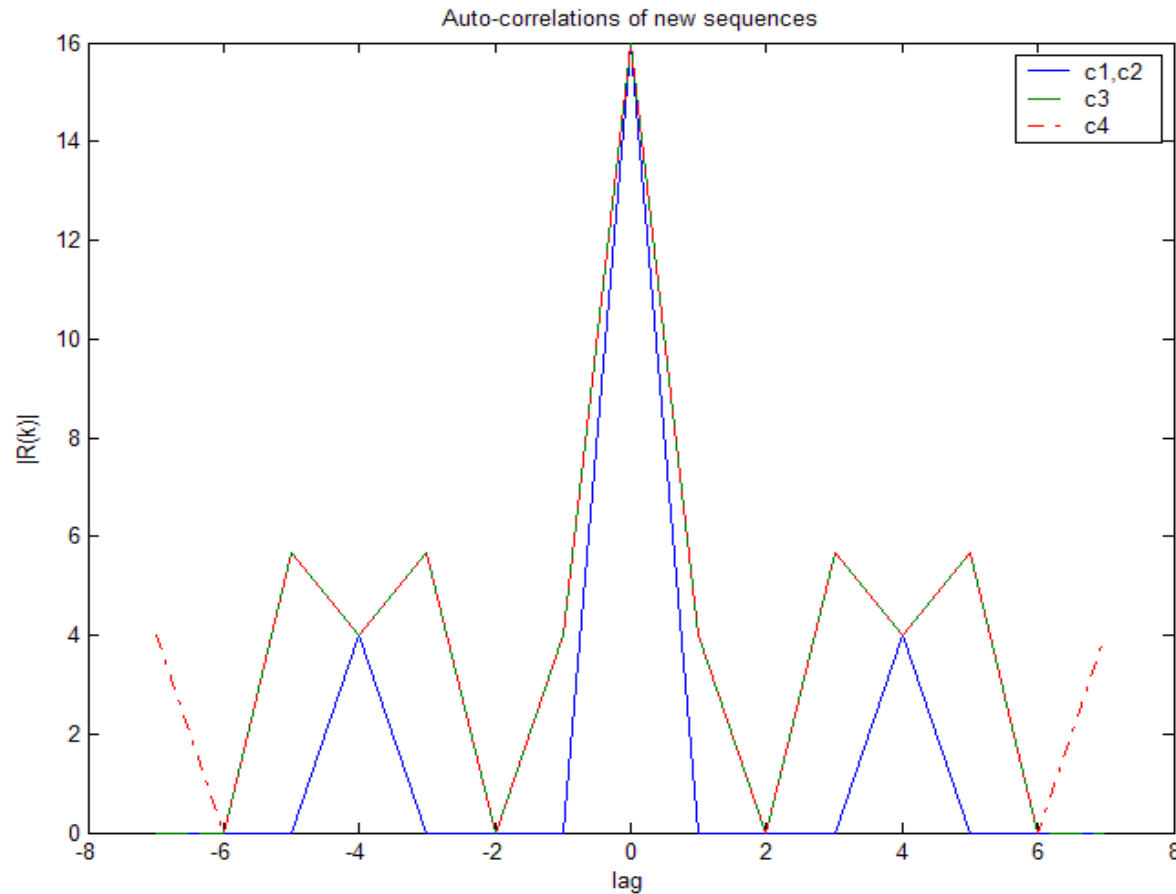

VARIOUS DUPLEX CANDIDATES (7)

- Cross-correlations of sequences for Code Division Duplex (CDD)

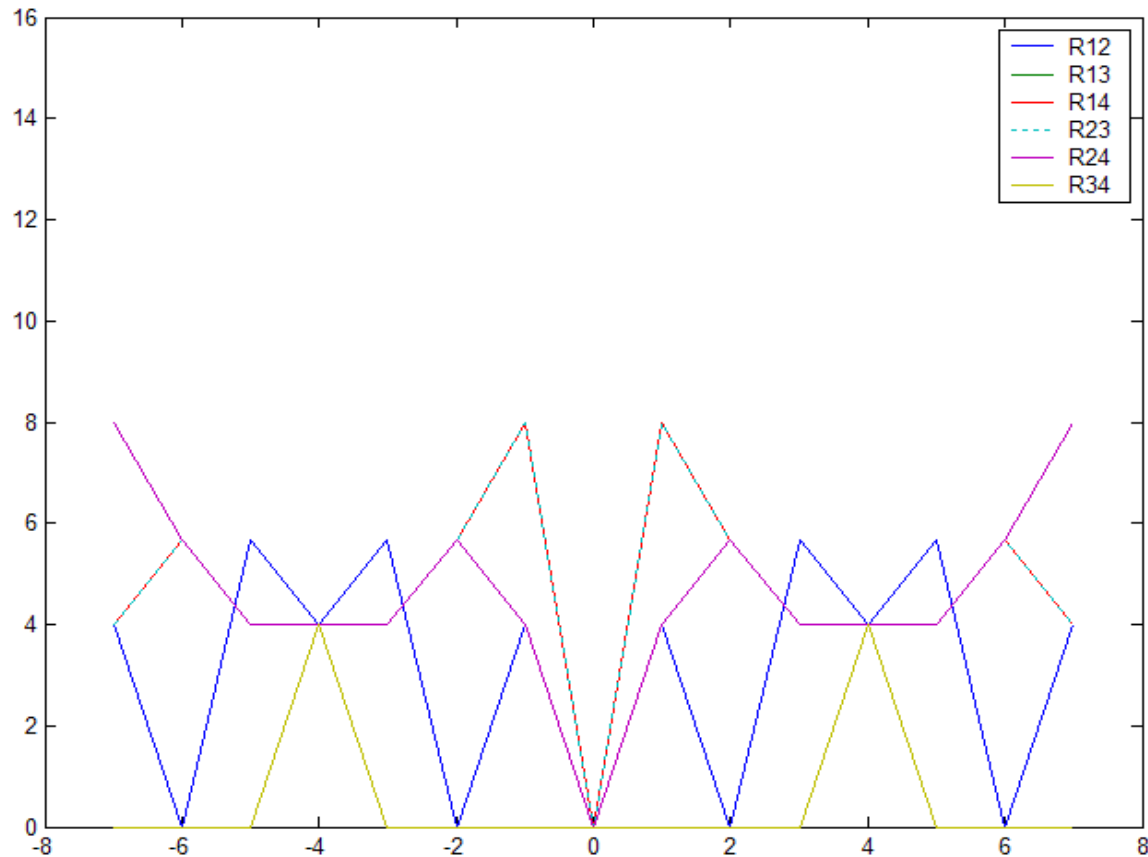

MULTI-HOP VLC FOR EXTENDED RANGES

MULTI-HOP VLC (1)

- To cover broader area in indoor environment or to overcome short range problem
 - An in-building space is divided into multiple cells.
 - Each cell has its own base station (or access point).
 - It is assumed that these base stations do not communicate with each other through an infra network.
 - To connect all base stations, some relays/repeaters are to be deployed to connect all base stations.
 - A mobile/fixed unit in a cell can communicate with a unit in another cell through a multiple hop connection.

* 15-08-0790-01-0vlc-Technical-Issues-on-VLC

MULTI-HOP VLC (2)

- To cover broader area in indoor environment and to increase communication ranges
 - A server/gateway can be connected to only one base station.
 - Other base stations are connected with other base stations through multiple hop links. → **small mesh network**

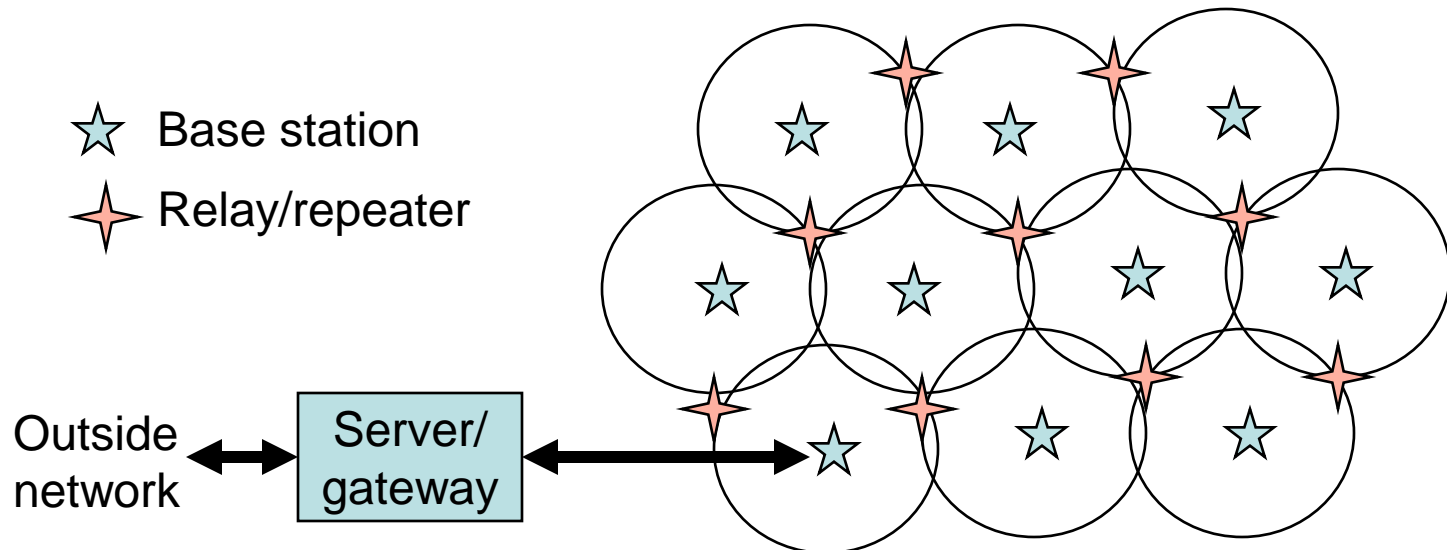

* 15-08-0790-01-0vlc-Technical-Issues-on-VLC

MULTI-HOP VLC (3)

- Advantages with multi-hop VLC:
 - Simple infrastructure to form a network among base stations
 - Ubiquity can be easily realized.
 - Quick deployment and flexible network configuration without additional infra networks.
 - For temporary events and places
 - Easy installation for places where frequent configuration changes are required
 - Short range can be overcome with multiple cells (or hops).
 - Line-of-sight problem can be overcome **with dynamic routing scheme**.
 - Abrupt blocking problem can be solved by switching routes – by changing to an alternative route.

* 15-08-0790-01-0vlc-Technical-Issues-on-VLC

CONCLUSIONS

CONCLUSIONS

GOAL OF THIS WORK FOR THE PROPOSAL

- is to achieve
maximum flexibility to accomodate
 - various applications
 - multiple data rates
 - various signal environments/situationsin the design of 15.7 systems and ultimately in the 15.7 standard

by providing **more efficient and simpler** technologies and concepts.

Simplicity is the highest priority for this design.