

Project: IEEE P802.15 Working Group for Wireless Personal Area Networks (WPANs)

Submission Title: [DecaWave PHY Proposal]

Date Submitted: [9th July 2009]

Source: [Michael Mc Laughlin]

Company [DecaWave Limited]

Address [Digital Depot, Thomas Street, Dublin 8, Ireland]

Voice:[+353-87-688-2514] **Fax:**[What's a fax?] **E-Mail:**[michael.mclaughlin@decawave.com]

Re : [Response to Call for Proposals]

Abstract:[DecaWave PHY Proposal]

Purpose:[Introduce IEEE 802.15.4f TG meeting attendees to DecaWave's proposal for a PHY for 802.15.4f active RFID]

Notice: This document has been prepared to assist the IEEE P802.15. It is offered as a basis for discussion and is not binding on the contributing individual(s) or organization(s). The material in this document is subject to change in form and content after further study. The contributor(s) reserve(s) the right to add, amend or withdraw material contained herein.

Release: The contributor acknowledges and accepts that this contribution becomes the property of IEEE and may be made publicly available by P802.15.

Proposal for 802.15.4f

- Use **UWB** PHY from **802.15.4a** as the PHY layer for **802.15.4f**
- Add an informative annex to describe how 15.4 supports RFID applications
 - How the mandatory 64 bit ID is signalled
 - How the optional additional ID is signalled
 - How optional sensor + other user Data is signalled
- Instead of 8GHz mandatory high band make *either* 6.5GHz *or* 8GHz mandatory for high band modes, depending on national availability.
- Incorporate known 802.15.4a errata (15-07-0666-01-004a-802-15-4a-2007-errata-DRAFT.doc)
- Add new one-way messaging capability to the MAC or clarify how the existing MAC can be used for this.

Summary of 802.15.4a- UWB

- Ultra-Wideband alternative PHY for 802.15.4
- Advantages vis-à-vis 15.4:
 - Lower power
 - Better multipath immunity
 - Precision RTLS capable
 - High Data rates
 - Allows shorter packets, higher tag density, even lower power
- Bitrates
 - 110kbps, 850kbps, 6.8Mbps, 27Mbps
- Pulse Repetition Frequencies
 - 4MHz, 15.6MHz, 62.4MHz
- Modulation scheme
 - Burst position modulation with BPSK
- FEC Scheme
 - Systematic Convolutional Code
 - Reed Solomon code

Summary of 802.15.4a- UWB cont.

- Ideal channel sounding preamble
 - Periodic autocorrelation is an *impulse* or *kroncker delta function*
- Bandwidth
 - 500MHz, 1100MHz or 1300MHz
- Channels
 - 15 channels from 3GHz to 10GHz
- Designed to be usable for one-way or two way ranging
- Complexity choice for receiver
 - coherent or non-coherent demodulation
 - FEC can be ignored by receiver
 - 802.15.4a convolutional code is very simple
 - DecaWave Viterbi decoder is only 3k gates
- Complexity choice for transmitter. Either:
 - Pseudo Random Burst of Bipolar Pulses
 - Allows Coherent Decode
 - Spurge of Energy whose position is determined by data (C.O.O.K.)
 - Only Non-coherent Decode

Coherent Link Margin and Range

Parameter	802.15.4a		
Throughput	110 kb/s	850 kb/s	6800 kb/s
Bandwidth	1300 MHz	500 MHz	1300 MHz
Spectral Density (dBm/MHz)	-41.3 dBm/MHz	-41.3 dBm/MHz	-41.3 dBm/MHz
Average Tx power, P_T (Taking backoff into account)	-10.2 dBm	-14.3 dBm	-10.2 dBm
Tx antenna gain, G_R	0 dBi	0 dBi	0 dBi
Geometric center frequency $\sqrt{f_{\min} \cdot f_{\max}}$	3992 MHz	3992 MHz	3992 MHz
Path loss at 1 meter. $L_1 = 20 \log_{10}(4\pi f_c/c)$	44.5 dB	44.5 dB	44.5 dB
Additional Path loss at d m $L_2 = 10 \log_{10}(d^2)$	53.0 dB	39.9 dB	35.0 dB
Rx antenna gain, G_R	0 dBi	0 dBi	0 dBi
Rx Power at 1 metre	-55 dBm	-59 dBm	-54.6 dBm
Rx Power P_R at Max Distance	-108 dBm	-99 dBm	-90 dBm
Rx Noise Power	-76.9 dBm	-81.0 dBm	-76.9 dBm
Antenna noise power per bit	-123.6 dBm	-114.7 dBm	-105.7 dBm
Rx Noise Figure Referred to the Antenna N_F	6 dB	6 dB	6 dB
A/D in noise power per bit, P_N	-118 dBm	-109 dBm	-100 dBm
Minimum E_b/N_0 (S)	6 dB	6 dB	6 dB
Implementation Loss	4 dB	4 dB	4 dB
Tx backoff (Tx spectrum not flat, Power level not ideal)	0 dB	0 dB	0 dB
Fading Loss	2 dB	2 dB	2 dB
Min. Rx Sensitivity Level	-108 dBm	-99 dBm	-90 dBm
SNR	-31 dB	-18 dB	-13 dB
LOS Distance	445 m	99 m	57 m
Indoor NLOS Distance	40 m	21 m	17 m

An Ultra Wideband Channel Model

The curves below represent the mean and worst 10% attenuation plotted as a function of distance.

The red curves are for a signal with 20MHz bandwidth

The green curves are for a signal with 500MHz bandwidth

It can be seen that the wider bandwidth has much lower worst 10% attenuation

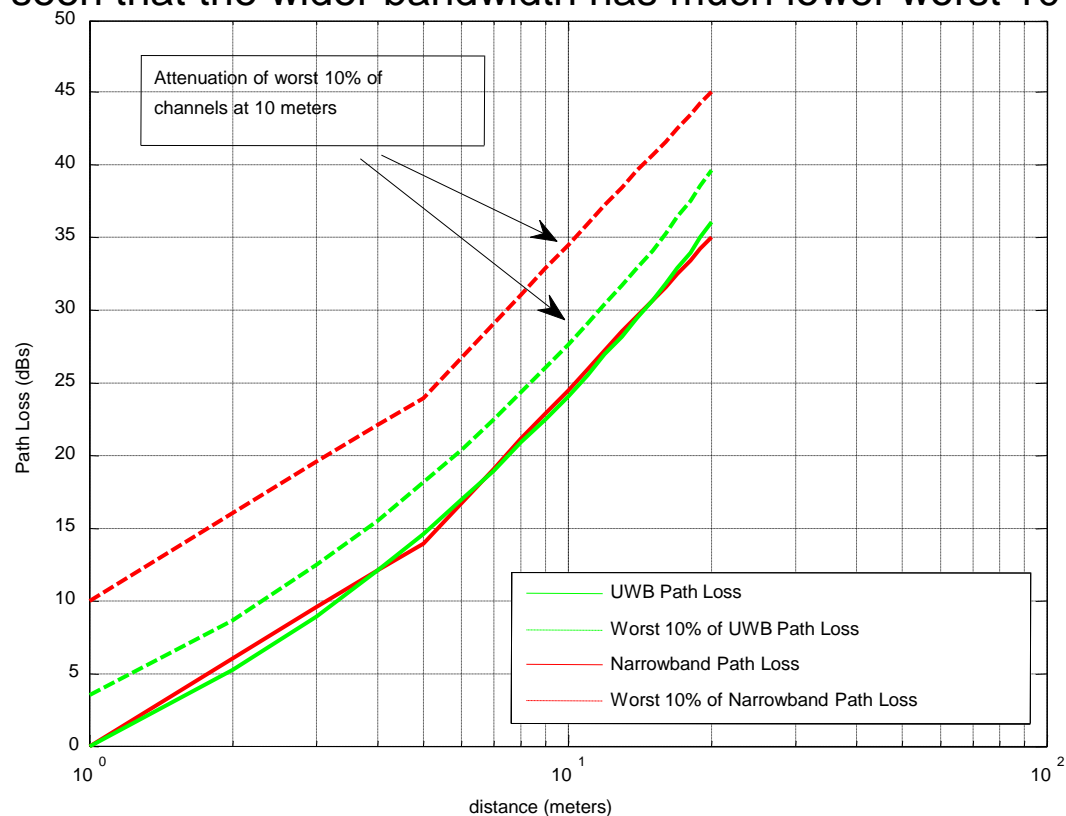

802.15.4a Receive Signal Buried In Thermal Noise

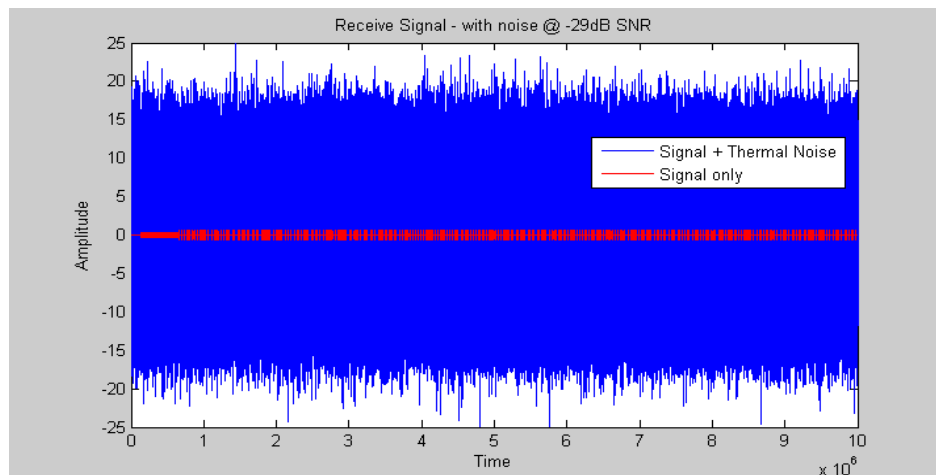

15.4a Receive Signal @ 110kps and noise at -31dB SNR. This corresponds to a distance of 450 meters outdoors, 40 meters indoors

15.4a Receive Signal @ 6.8Mbps and noise at -11dB SNR. This corresponds to a distance of 60 meters outdoors, 17 meters indoors

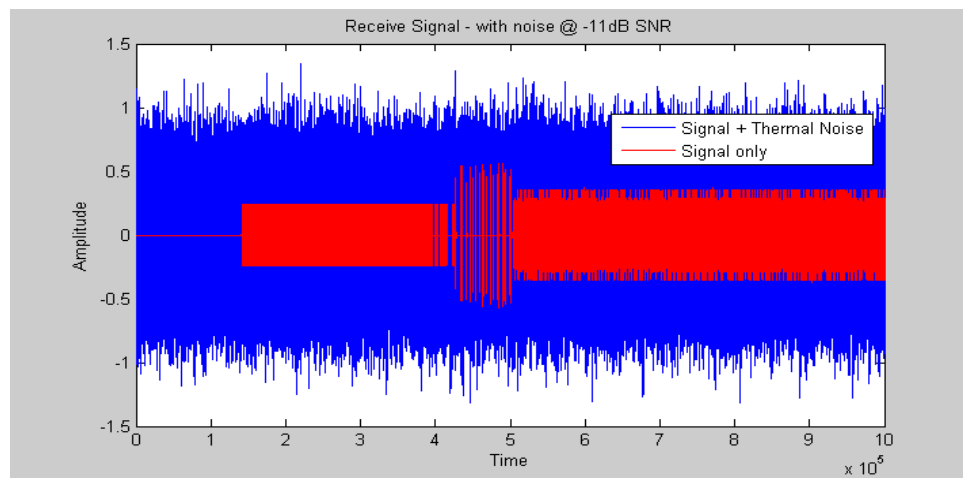

Bandplan Facilitating WorldWide Deployment

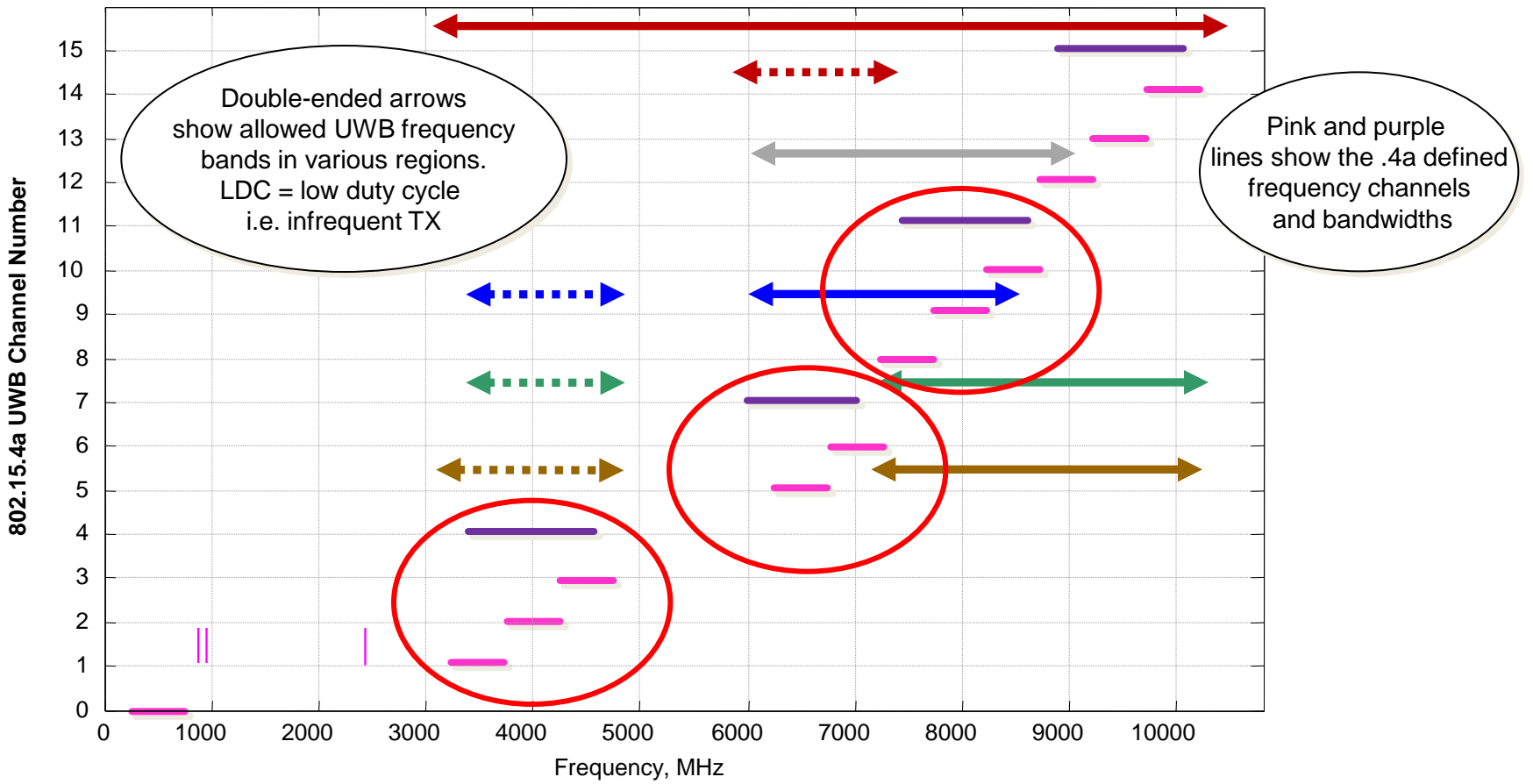

	.4a 500MHz			North America			Japan @ >50Mbps
	.4a >1GHz			USA indoors and out			Japan until end 2010
	802.15.4			Europe			Korea
				Europe with LDC			Korea with LDC
				China			China

Coherent or Non-Coherent Decode

- IEEE 802.15.4a-UWB was designed to be used by *either* a coherent *or* non-coherent receiver
- Some quotes from the published standard:

“The modulation used in the ultra-wide band (UWB) physical layer (PHY) that combines both binary phase-shift keying (BPSK) and pulse position modulation (PPM) so that both coherent and non-coherent receivers can be used to demodulate the signal.”

“the UWB PHY also provides a hybrid modulation that enables very simple, non-coherent receiver architectures to further minimize power consumption and implementation complexity.

“A combination of burst position modulation (BPM) and binary phase-shift keying (BPSK) is used to support both coherent and non-coherent receivers using a common signalling scheme. The combined BPM-BPSK is used to modulate the symbols, with each symbol being composed of an active burst of UWB pulses”

FEC and Symbol Structure

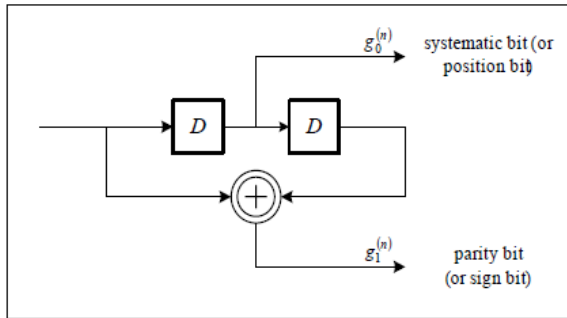

Determines which half of symbol contains burst

Determines whether or not entire burst is inverted

Figure 27k—Systematic convolutional encoder

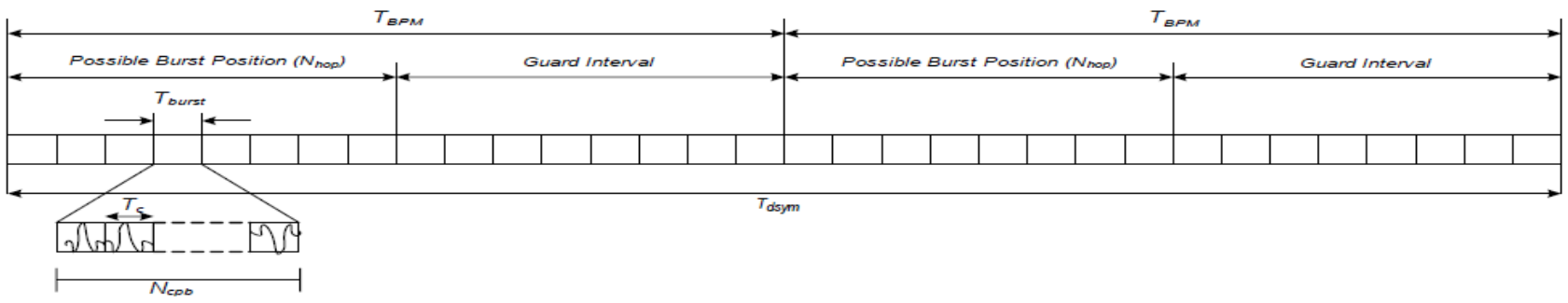
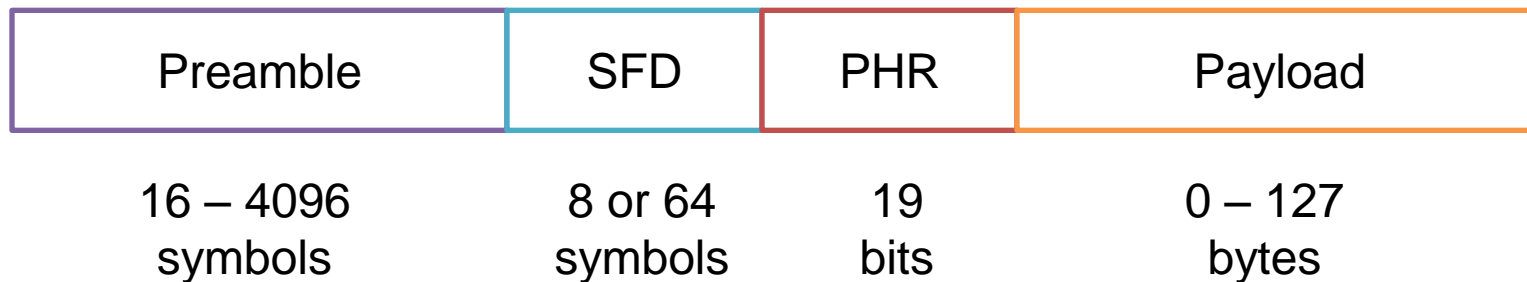

Figure 27c—UWB PHY symbol structure

Single burst of pulses with pseudo-random individual polarity

15.4a UWB Packet Structure



AWGN PER of 802.15.4a

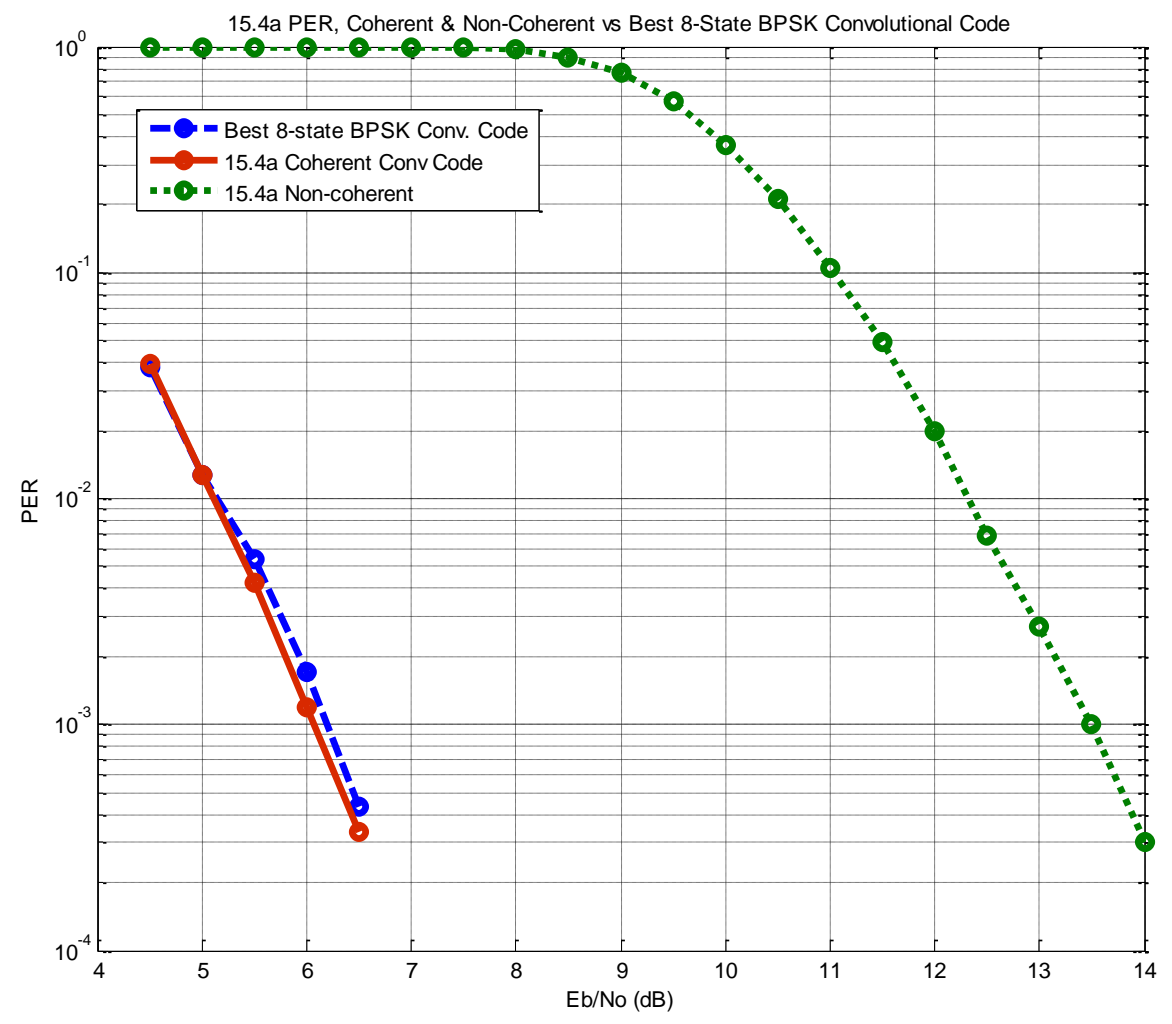

Channel Sounding Preamble

- Example preamble sequence

-1 +1 0 +1 +1 0 0 0 -1 +1 -1 +1 +1 0 0 +1 +1 0 +1 0 0 -1 0 0 0 0 -1 0 +1 0 -1

- This has “Perfect” periodic auto correlation thus:

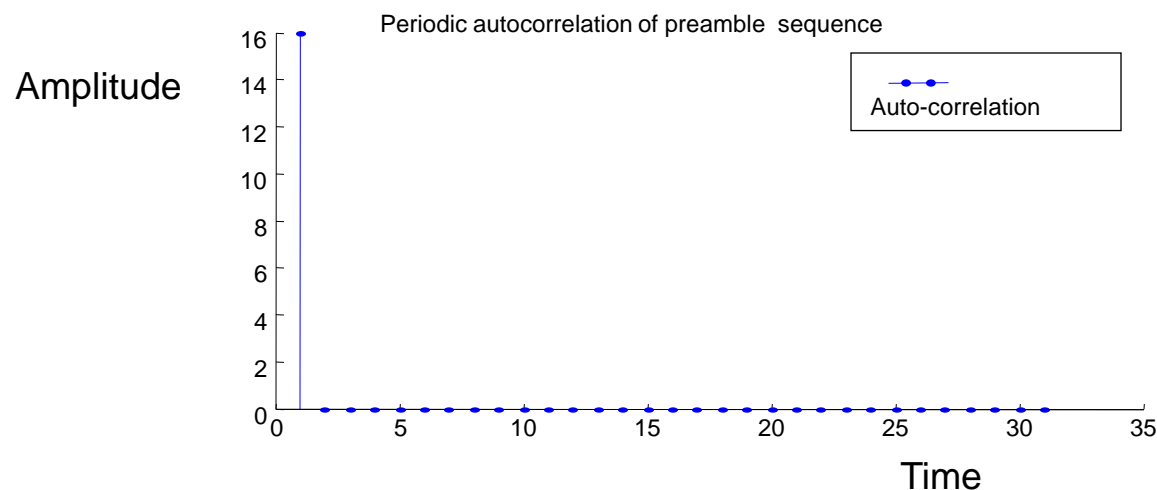

- Now, a non-coherent receiver only sees if there is energy there or not i.e. this

+1 +1 0 +1 +1 0 0 0 +1 +1 +1 +1 +1 0 0 +1 +1 0 +1 0 0 +1 0 0 0 0 +1 0 +1 0 +1

Non-coherent channel sounding

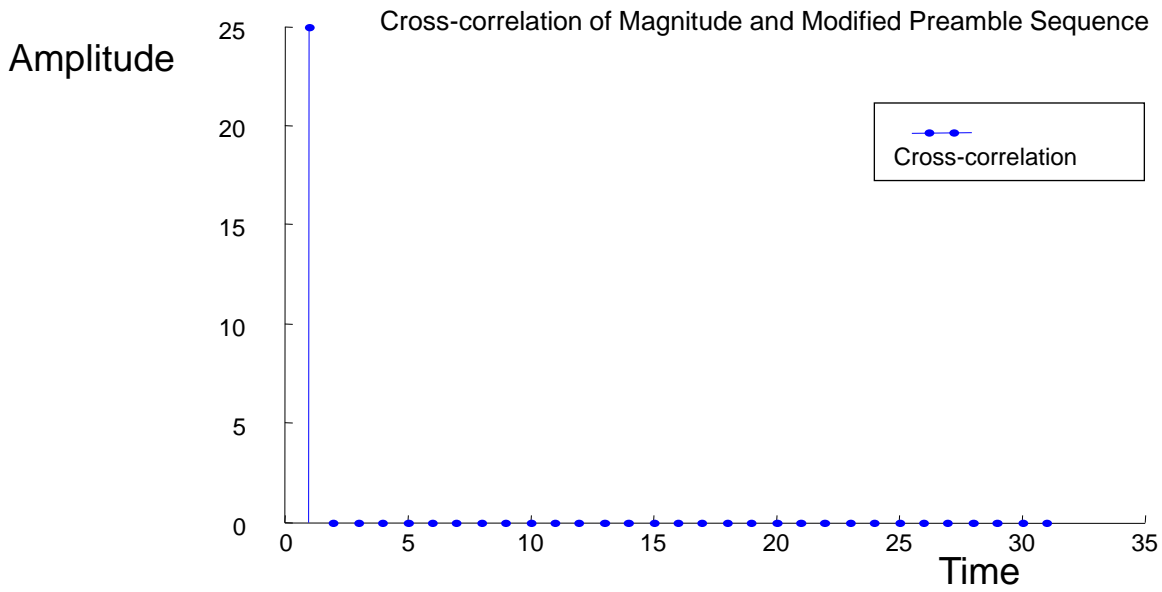

This show the cross correlation of

+1 +1 0 +1 +1 0 0 0 +1 +1 +1 +1 +1 0 0 +1 +1 0 +1 0 0 +1 0 0 0 0 +1 0 +1 0 +1

With

+1 +1 -1 +1 +1 -1 -1 -1 +1 +1 +1 +1 +1 -1 -1 +1 +1 -1 +1 -1 -1 +1 -1 -1 -1 -1 +1 -1 +1 -1 +1

i.e. 0 replaced by -1

IEEE 802.15.4a-UWB Ranging Options

Two way ranging option

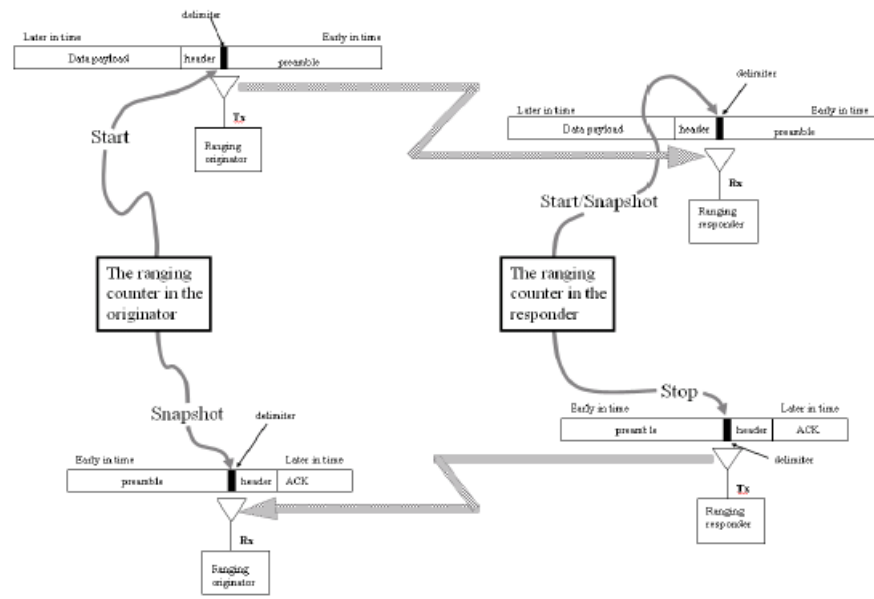

Figure 13a—The complete two-way ranging exchange

IEEE 802.15.4a-UWB Ranging Options

- IEEE 802.15.4a-UWB has the option of being transmit only

“The capabilities required to accomplish one-way ranging are sufficiently similar that this standard allows operation in that mode as well”



COOK Transmitter option

- Many of the original companies who worked on 802.15.4a wanted a way to do a simple OOK transmitter and receiver.
- A joint contribution was submitted by a group of these companies, including Samsung and ETRI. The full contribution can be downloaded from the IEEE website:

15-05-0132-03-004a-merged-proposal-chaotic-uw-b-system-802-15-4a.pdf
- The task group listened to their concerns and the result was Annex-H of 802.15.4a.
- This defines an optional OOK type modulation

802.15.4a Annex H: COOK option

- Extract from 802.15.4a:

“Another noncoherent optional pulse shape that may be used is a chaotic waveform. This optional pulse shape shall be used only when all other devices within the PAN are using a chaotic pulse. This mode can be used for low-power applications where long battery life is critically important.

Since chaotic on-off keying (COOK) is noncoherent modulation, the receiver does not need to generate a corresponding chaotic signal for demodulation. For that reason, **the technique chosen for generating a chaotic waveform can be freely determined by implementers.**”

Benefits of COOK

- The UWB transmitter can be implemented with a few discrete components
- Instead of a coherent burst of pseudo random pulses with a predictable pattern that the receiver can compare with, in Annex H, the transmitter just sends a burst of energy in the band of interest.
- The beauty of Annex H from a non-coherent OOK point of view is that it doesn't matter what type of energy you send. The receiver is not expecting a coherent signal. Although it is referred to as a chaotic signal, it can be anything at all. The implementer decides what to generate and how to generate it.
- This allows a conventional 4a transmitter to transmit a coherent train of pseudo random pulses, but also allows, for example, a COOK transmitter, which works directly in the band of interest, to just send a spurge of energy.
- This system has precisely the same performance as conventional OOK for the same average transmit power
- Because regulations limit the power of the worst case data packet, COOK has a 3dB advantage over OOK in practice

2. CHAOTIC COMMUNICATION SYSTEM

Chaotic Source

- Chaotic source generates oscillations directly in a specified microwave band.
- Information component is put into the chaotic carrier to form a stream of chaotic radio pulses.
- Information can be retrieved from the chaotic radio pulses without intermediate heterodyning.

Chaotic Source Generator Circuit

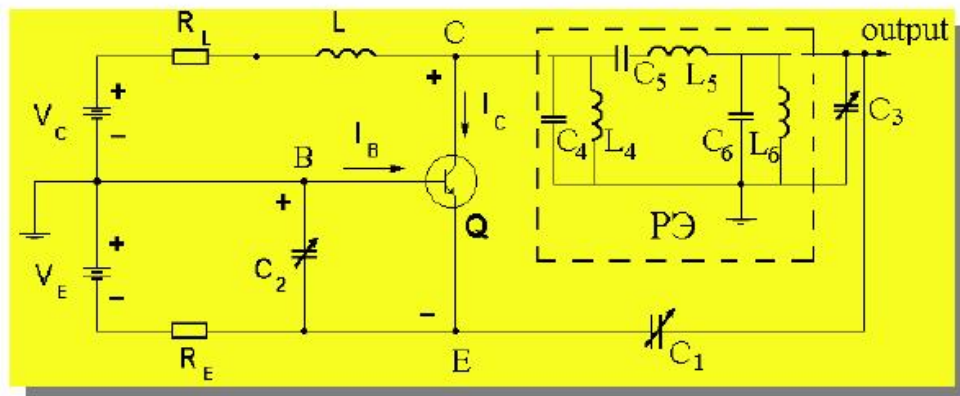

Experiment device

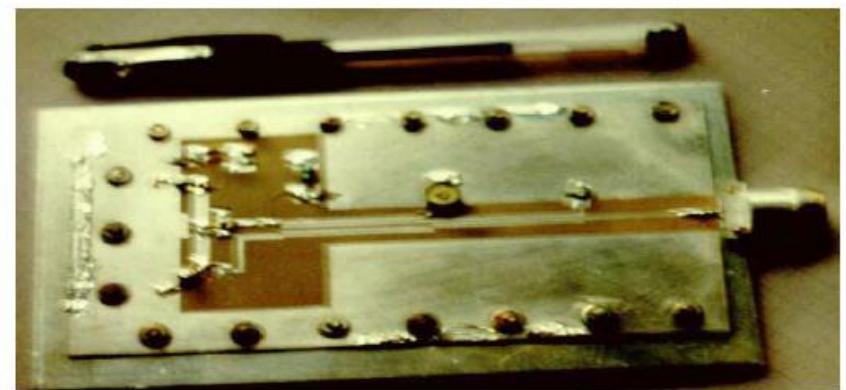

3.4. Technical Feasibility

Prototype 1

- The communication test has successfully done using Chaotic pulses

UWB DCC-OOK Test-bed

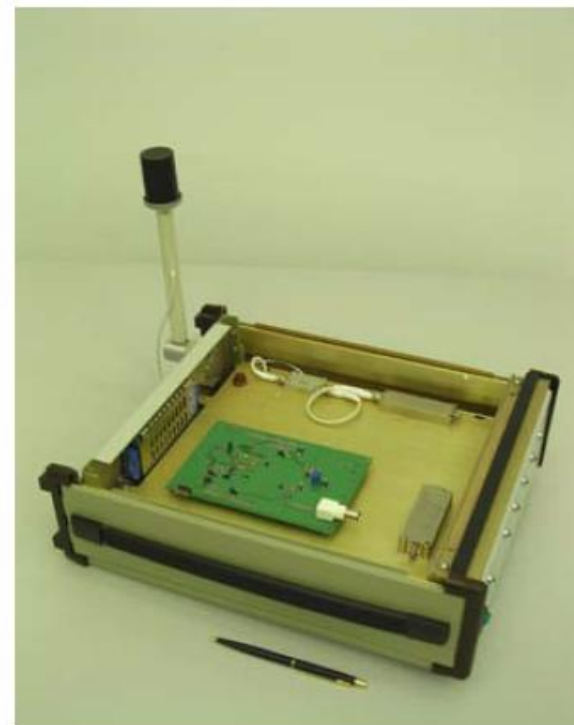
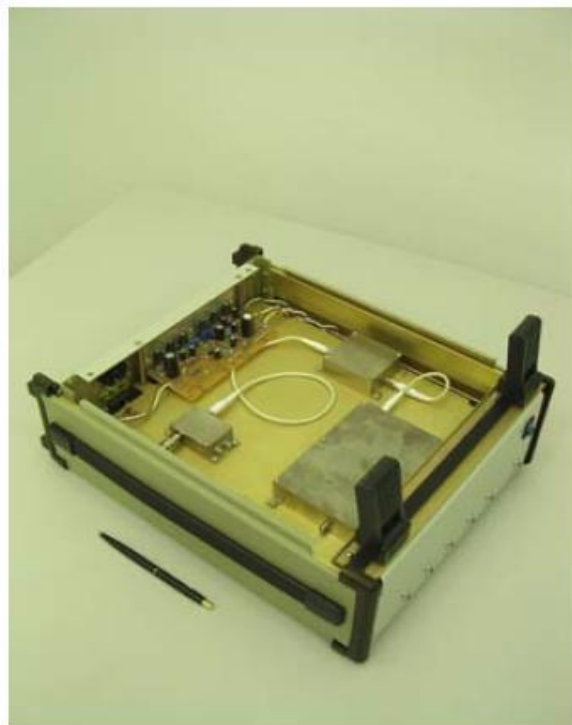

Summary

- IEEE802.15.4a-UWB is an extremely low complexity ultra wideband communications and RTLS Standard
- Many companies and individuals with wide-ranging expertise worked on 4a
 - It has been scrutinised by many pairs of eyes
- Non-coherent option enables ultra-low cost receiver implementations
- Transmitter is very simple to implement
 - COOK option can be assembled from readily available components
- Coherent receiver option allows much larger range
 - Complexity of RFID reader is usually less critical than tag