

Project: IEEE P802.15 Working Group for Wireless Personal Area Networks (WPANs)

Submission Title: MedWiN Physical Layer Proposal

Date Submitted: 04 May, 2009

Source: David Davenport (1), Neal Seidl (2), Jeremy Moss (3), Maulin Patel (4), Anuj Batra (5), Jin-Meng Ho (5), Srinath Hosur (5), June Chul Roh (5), Tim Schmidl (5), Okundu Omeni (6), Alan Wong (6)
(1) GE Global Research, davenport@research.ge.com, 518-387-5041, 1 Research Circle, Niskayuna, NY, USA
(2) GE Healthcare, neal.seidl@med.ge.com, 414-362-3413, 8200 West Tower Ave., Milwaukee, WI, USA
(3) Philips, j.moss@philips.com, +44 1223 427530, 101 Cambridge Science Park, Milton Road, Cambridge, UK
(4) Philips, maulin.patel@philips.com, 914-945-6156, 345 Scarborough Rd., Briarcliff Manor, NY, USA
(5) Texas Instruments, {batra, jинmengho, hosur, jroh, schmidl}@ti.com, 12500 TI Blvd, Dallas, TX, USA
(6) Toumaz Technology, {okundu.omeni, alan.wong}@toumaz.com, Bldg 3, 115 Milton Park, Abingdon, Oxfordshire, UK

Re: Response to IEEE 802.15.6 call for proposals

Abstract: This document describes the MedWiN physical layer proposal for IEEE 802.15.6

Purpose: For discussion by IEEE 802.15 TG6

Notice: This document has been prepared to assist the IEEE P802.15. It is offered as a basis for discussion and is not binding on the contributing individual(s) or organization(s). The material in this document is subject to change in form and content after further study. The contributor(s) reserve(s) the right to add, amend or withdraw material contained herein.

Release: The contributor acknowledges and accepts that this contribution becomes the property of IEEE and may be made publicly available by P802.15.

MedWiN Physical Layer Proposal

GE Global Research: David Davenport

GE Healthcare: Neal Seidl

Philips: Jeremy Moss, Maulin Patel

Texas Instruments: Anuj Batra, Jin-Meng Ho
Srinath Hosur, June Chul Roh
Tim Schmidl

Toumaz Technology: Okundu Omeni, Alan Wong

Outline

- Requirements of medical applications
- Details about MedWiN PHY
 - TX/RX architecture
 - Band plan
 - System Parameters
 - Coding and spreading
 - Frame format: preamble, header, PSDU
- Performance Results:
 - Link budget, sensitivity, system performance in multi-path
 - Multiple co-located networks
 - TX mask, signal robustness and coexistence
 - Complexity and power consumption
- Summary and Conclusions

Requirements for Medical Applications

- Very low-power consumption: Solutions should support ≤ 3 mA, 1V paper batteries
- Low-complexity: solution needs to support small form factors
- Wireless link should be robust to support bounded latency and minimize data loss
- PHY information data rate should be greater than the sensor information data rate
 - Allows devices to save power via duty cycling and hibernation
- Support for multiple co-located BAN networks (patients), where each network can support multiple sensors
- Coexistence with other BAN networks and Robustness to other wireless technologies
- Support for multiple frequency band to enable operation within or on the body surface

Proposed MedWiN Physical Layer*

*More details about the MedWiN Physical Layer
can be found in the latest version of 15-09-0329-00-0006

Overview of MedWiN Physical Layer

- PHY is optimized for medical applications:
 - Scalable data rates: 100 – 1000 kbps – allows for tradeoff of range vs. rate
 - Support for multiple frequency bands of operation
- PHY solution enables very low-power consumption via low complexity
- Simple and low complexity modulation parameters:
 - Single carrier PHY with DPSK – eliminates need for channel estimation
 - Spreading, low-complexity binary block codes – robustness for multipath and interference
 - Multiple robust preambles – minimizes false alarms due to adjacent channel leakage
 - Compact and robust PLCP header – minimizes overhead
- Support for at least 10 simultaneously operating networks (multiple networks)
- Coexistence with other BAN networks and other wireless technologies

Example TX Architecture

- PLCP Header:

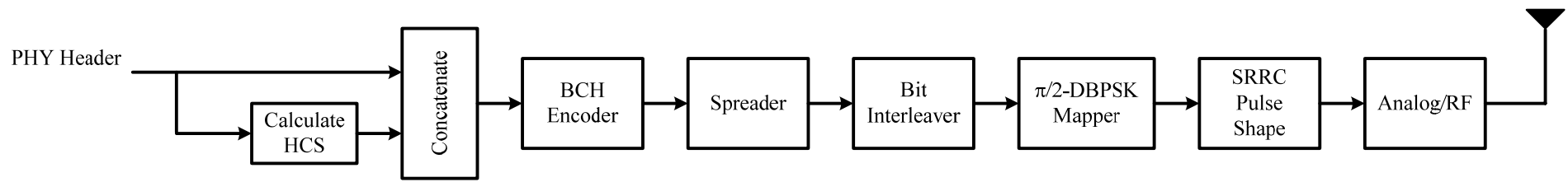

- PSDU:

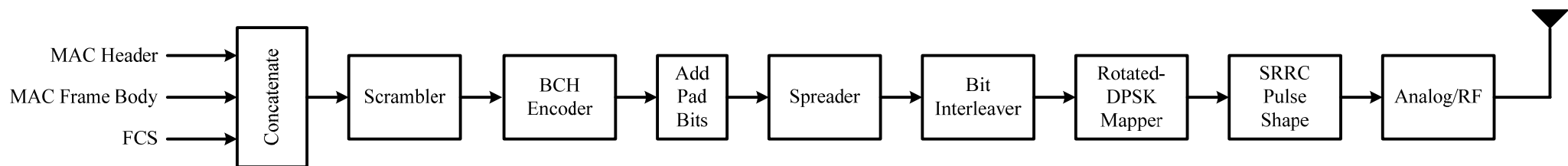

Example RX Architecture

- PLCP Header:

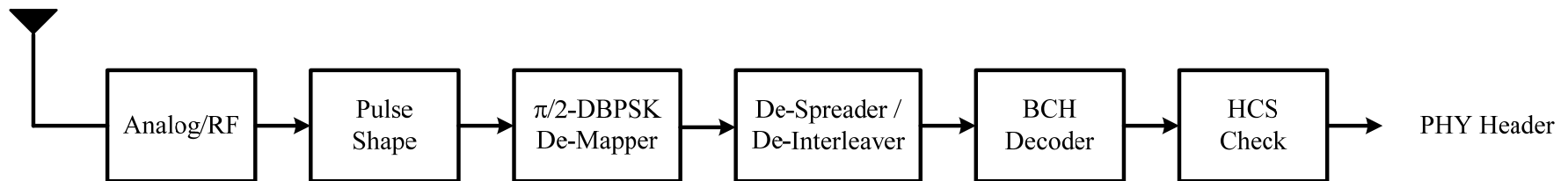

- PSDU:

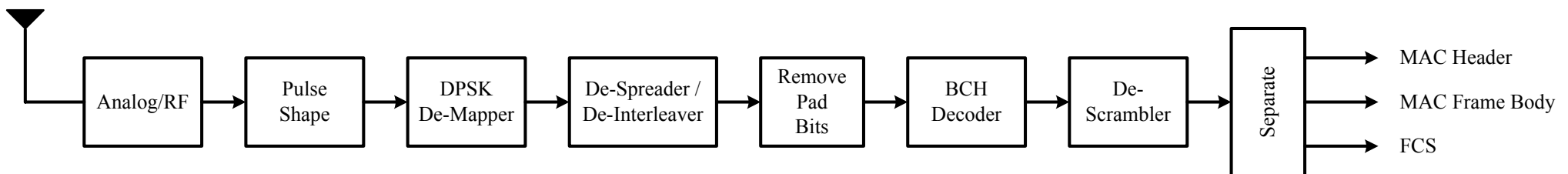

Band Plan and Channelization

- A compliant device must support at least one of the frequency bands:
 - 2400 – 2483.5 MHz (ISM, worldwide)
 - 2360 – 2400 MHz (proposed in US)
 - 402 – 405 MHz (MICS)
 - 902 – 928 MHz (US)
 - 950 – 956 MHz (Japan)
 - 863 – 870 MHz (Europe)

- Relationship between center frequency f_c and channel number n_c :

Frequency Band (MHz)	Relationship between f_c and n_c
2400 – 2483.5	$f_c = 2402.00 + 1.00 \times n_c$ (MHz), $n_c = 0, \dots, 78$
2360 – 2400	$f_c = 2362.00 + 1.00 \times n_c$ (MHz), $n_c = 0, \dots, 37$
402 – 405	$f_c = 402.15 + 0.30 \times n_c$ (MHz), $n_c = 0, \dots, 9$
902 – 928	$f_c = 903.50 + 0.50 \times n_c$ (MHz), $n_c = 0, \dots, 47$
950 – 956	$f_c = 951.10 + 0.40 \times n_c$ (MHz), $n_c = 0, \dots, 11$
863 – 870	$f_c = 865.60 + 0.20 \times g(n_c)$ (MHz), $n_c = 0, \dots, 14$

$$g(n_c) = \begin{cases} n_c & 0 \leq n_c \leq 9 \\ n_c + 3 & 10 \leq n_c \leq 11 \\ n_c + 4 & 12 \leq n_c \leq 13 \\ n_c + 7 & n_c = 14 \end{cases}$$

Key System Parameters

- Rotated-Differential M-PSK:
 - Information is encoded in the phase transitions between symbols
 - No need for channel estimation at receiver, eliminating a big block at receiver
 - Rotation minimizes peak-to-average ratio (PAR): 0.5 – 1.8 dB
 - Support for $\pi/2$ -DBPSK, $\pi/4$ -DQPSK is mandatory, $\pi/8$ -D8PSK is optional
- Pulse shape is square-root raised cosine (SRRC)
 - Can use a simple SRRC and still meet TX mask and regulatory requirements
 - Simple SRRC can be implemented efficiently and with low power
- Simple, low-complexity binary BCH codes:
 - Codes are cyclical codes and can be implemented using shift-registers
 - Header: BCH (31, 16, $t = 3$)
 - PSDU: BCH (63, 51, $t = 2$), (63, 49, $t = 3$), (63, 39, $t = 4$)
 - Possible to share hardware between the different BCH codes
- Simple and low-complexity spreading via repetition and bit interleaving

System Parameters (1)

Frequency Band (MHz)	Constellation	M	Symbol Rate (ksps)	Pulse Shape	Code Rate (k/n)	Spreading Factor (S)	Information Data Rate (kbps)
2360 – 2483.5	$\pi/2$ -DBPSK	2	631.58	SRRC	51/63	4	127.8
	$\pi/2$ -DBPSK	2	631.58	SRRC	51/63	2	255.6
	$\pi/2$ -DBPSK	2	631.58	SRRC	51/63	1	511.3
	$\pi/4$ -DQPSK	4	631.58	SRRC	51/63	1	1022.6

Frequency Band (MHz)	Constellation	M	Symbol Rate (ksps)	Pulse Shape	Code Rate (k/n)	Spreading Factor (S)	Information Data Rate (kbps)
402 – 405	$\pi/2$ -DBPSK	2	176.47	SRRC	45/63	1	126.1
	$\pi/4$ -DBPSK	4	176.47	SRRC	45/63	1	252.1
	$\pi/4$ -DBPSK	4	176.47	SRRC	1/1	1	352.9
	$\pi/8$ -DQPSK	8	176.47	SRRC	51/63	1	428.6

System Parameters (2)

Frequency Band (MHz)	Constellation	M	Symbol Rate (ksps)	Pulse Shape	Code Rate (k/n)	Spreading Factor (S)	Information Data Rate (kbps)
902 – 928	$\pi/2$ -DBPSK	2	315.79	SRRC	51/63	2	127.8
	$\pi/2$ -DBPSK	2	315.79	SRRC	51/63	1	255.6
	$\pi/4$ -DBPSK	4	315.79	SRRC	51/63	1	511.3
	$\pi/8$ -DQPSK	8	315.79	SRRC	51/63	1	766.9

Frequency Band (MHz)	Constellation	M	Symbol Rate (ksps)	Pulse Shape	Code Rate (k/n)	Spreading Factor (S)	Information Data Rate (kbps)
950 – 956	$\pi/2$ -DBPSK	2	250.00	SRRC	39/63	1	154.8
	$\pi/2$ -DBPSK	2	250.00	SRRC	1/1	1	250.0
	$\pi/4$ -DBPSK	4	250.00	SRRC	1/1	1	500.0
	$\pi/8$ -DQPSK	8	250.00	SRRC	51/63	1	607.1

Frequency Band (MHz)	Constellation	M	Symbol Rate (ksps)	Pulse Shape	Code Rate (k/n)	Spreading Factor (S)	Information Data Rate (kbps)
863 – 870	$\pi/2$ -DBPSK	2	125.00	SRRC	51/63	1	101.2
	$\pi/4$ -DBPSK	4	125.00	SRRC	45/63	1	178.6
	$\pi/4$ -DBPSK	4	125.00	SRRC	1/1	1	250.0
	$\pi/8$ -DQPSK	8	125.00	SRRC	51/63	1	303.6

BCH Encoder

- BCH (31,16) code: $g(x) = 1 + x + x^2 + x^3 + x^5 + x^7 + x^8 + x^9 + x^{10} + x^{11} + x^{15}$
- Low-complexity, low-power implementation:

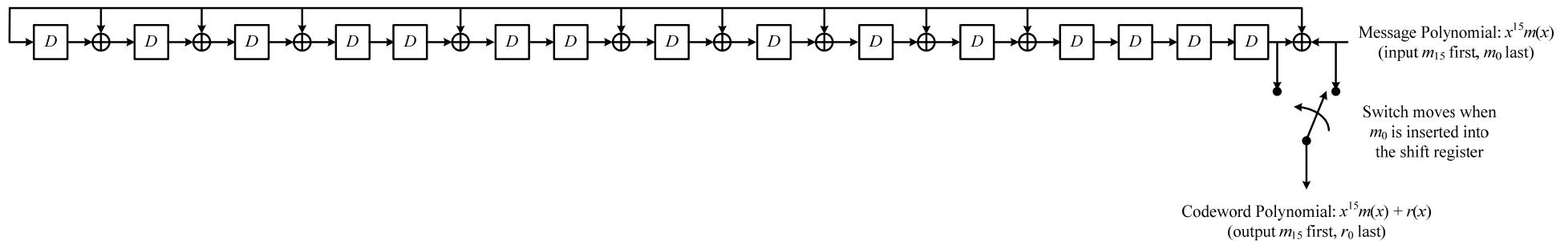

- BCH (63, 39): $g(x) = 1 + x + x^2 + x^4 + x^5 + x^6 + x^8 + x^9 + x^{10} + x^{13} + x^{16} + x^{17} + x^{19} + x^{20} + x^{22} + x^{23} + x^{24}$
- BCH (63, 45): $g(x) = 1 + x + x^2 + x^3 + x^6 + x^7 + x^9 + x^{15} + x^{16} + x^{17} + x^{18}$
- BCH (63, 51): $g(x) = 1 + x^3 + x^4 + x^5 + x^8 + x^{10} + x^{12}$
- Encoders and decoders can share hardware between the different BCH codes \Rightarrow small, low-complexity, low-power implementations possible

Spreading

- Spreading is required for three data rates:
 - 2400 MHz: 127.8, 255.6 kbps
 - 915 MHz: 127.8 kbps
- Spreading is implemented by repeating the bits S times and then interleaving the repeated bits using a simple, low-complexity two-bit interleaver

Ex: Spreading factor of 2

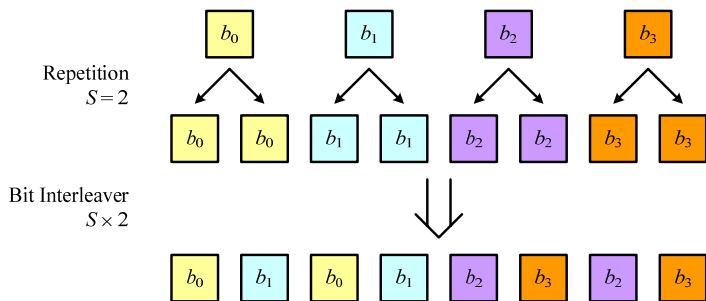

Ex: Spreading Factor of 4

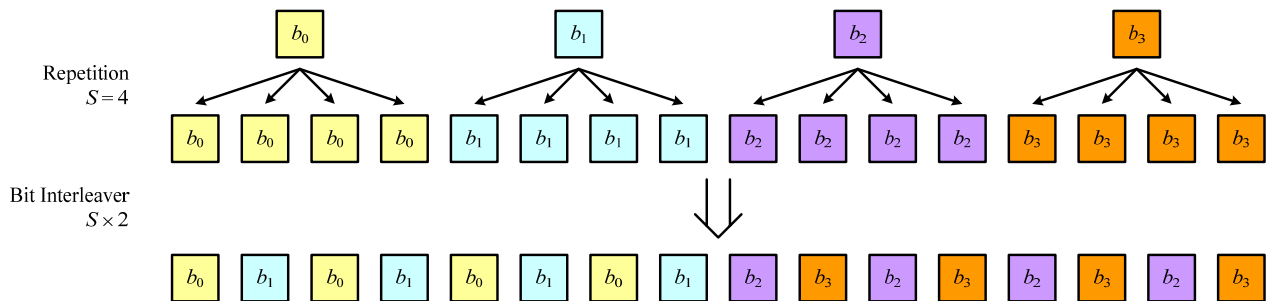

PLCP Frame Format

- PPDU comprised of three components:
 - PLCP Preamble: used for synchronization, carrier frequency offset estimation
 - PLCP Header: convey information about to decode PSDU
 - PSDU: MAC Header + MAC Frame Body (information) + FCS

- Structure:

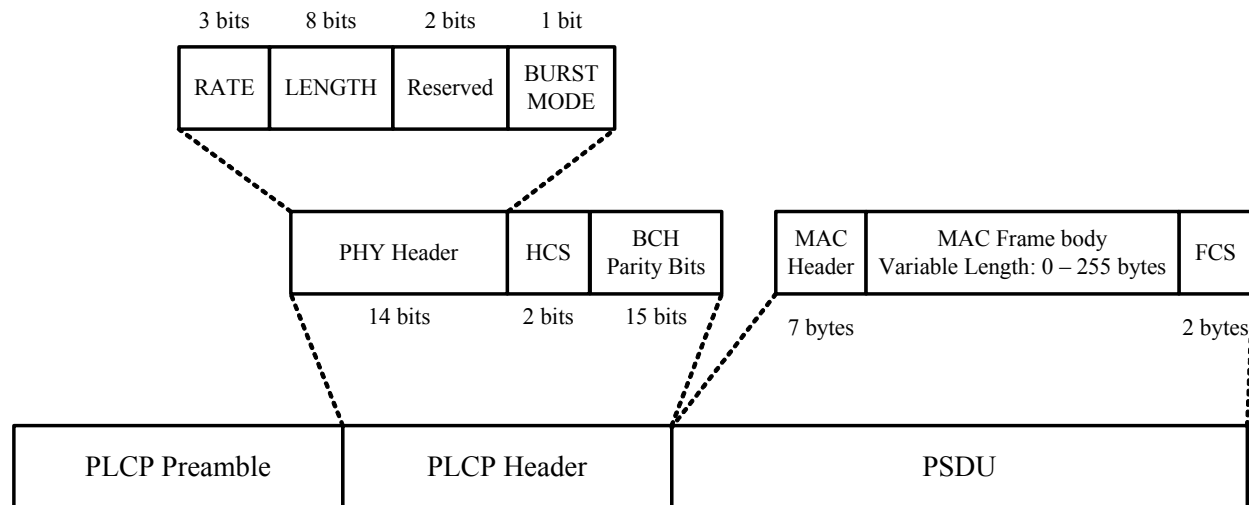

Process for BCH Encoding

1. Compute the number of bits in the PSDU: $N_{PSDU} = (N_{MACheader} + N_{MACFrameBody} + N_{FCS}) \times 8$
2. Calculate the number of BCH codeword: $N_{CW} = \left\lceil \frac{N_{PSDU}}{k} \right\rceil$
3. Compute the total number of shortening bits: $N_{shorten} = N_{CW} \times k - N_{PSDU}$
4. Calculate the number of shortening bits needed per codeword: $N_{spcw} = \left\lceil \frac{N_{shorten}}{N_{CW}} \right\rceil$
5. Distribute shortening bits uniformly over codewords:
 - a. Each of the first $rem(N_{shorten}, N_{CW})$ codewords have $N_{spcw} + 1$ shortened bits*
 - b. Remaining codewords have N_{spcw} shortened bits
6. Shortened bits are *not* transmitted on-air, but they *will be* re-inserted into known locations by receiver

*Shortened bits are message bits that are set to zero

PLCP Preamble

- Preamble = length-63 binary m-sequence followed by 010101010 sequence
 - M-sequence can be used for packet detection, coarse timing estimation and carrier-frequency offset estimation
 - 1+010101010 sequence can be used to refine timing estimation, can exploit 9 phase transitions (9 zero crossings)
- Specification supports two preambles with low-cross correlation properties
 - We can ensure that different preambles are used on adjacent channels
 - Low-cross correlation properties minimize the false alarms from the packet detection algorithm that could occur because channel select filters are loose and energy from adjacent channels could fold back into the desired channel
 - Minimizing false alarms reduces unnecessary power consumption
 - Cross-correlation provides 6.2 dB (= 15/63) of additional rejection
- Preamble #1 (#2) is assigned to even (odd) channels

PLCP Header

- Proposed PLCP Header Structure (31 bits)

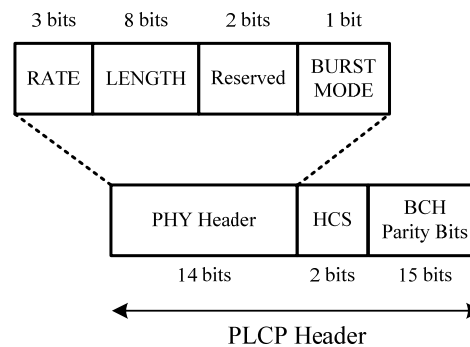

- Format the PHY header as shown above
- Calculate the 2-bit HCS value over the PHY header
- CRC-2 polynomial: $g(x) = 1 + x + x^2$
- Apply a BCH (31,16) code to PHY header + HCS

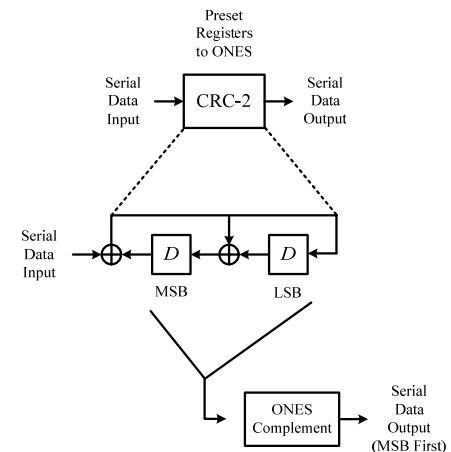

- Since PLCP Header uses a BCH (31,16) code, the header is sent at a lower data rate than the PSDU and therefore is more robust

PHY Header

- Structure:

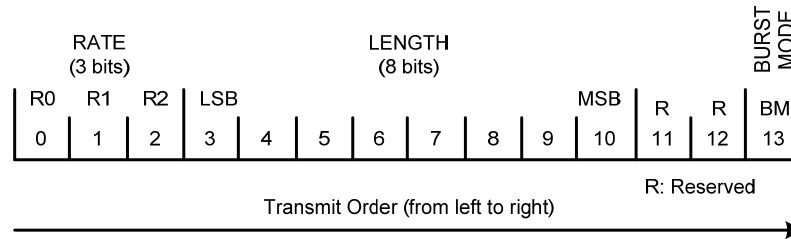

- RATE bits:
 - Mapping is unique for each frequency band

R0 – R2	Data Rate (kbps) 2360-2483.5 MHz	Data Rate (kbps) 402-405 MHz	Data Rate (kbps) 902-928 MHz	Data Rate (kbps) 950-956 MHz	Data Rate (kbps) 863-870 MHz
000	127.8	126.1	127.8	154.8	101.2
001	255.6	252.1	255.6	250.0	178.6
010	511.3	352.9	511.3	500.0	250.0
011	1022.6	428.6	766.9	607.1	303.6
100 – 111	Reserved	Reserved	Reserved	Reserved	Reserved

- Burst mode bit:

Burst Mode (BM) bit	Next Packet Status
0	Next packet <i>is not</i> part of burst
1	Next packet <i>is</i> part of burst

Packet Error Rate Curves (1)

- Assumptions: AWGN, zero carrier-frequency offset, ideal timing, PSDU = 256 bytes
- Constellation: $\pi/2$ -DBPSK (left), $\pi/4$ -DQPSK

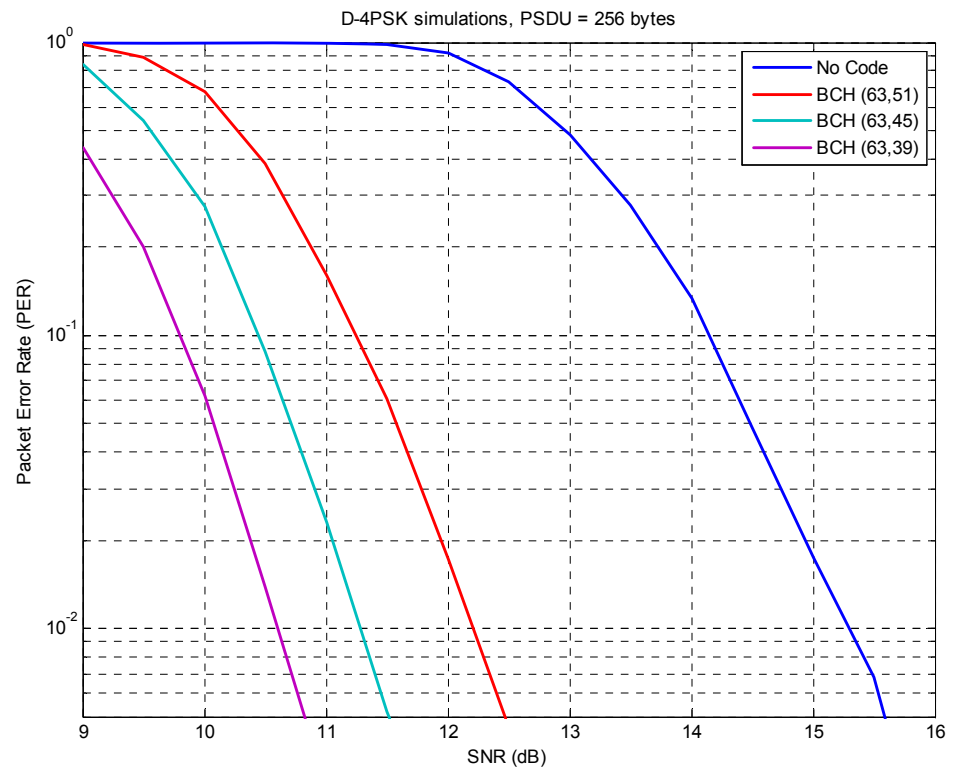
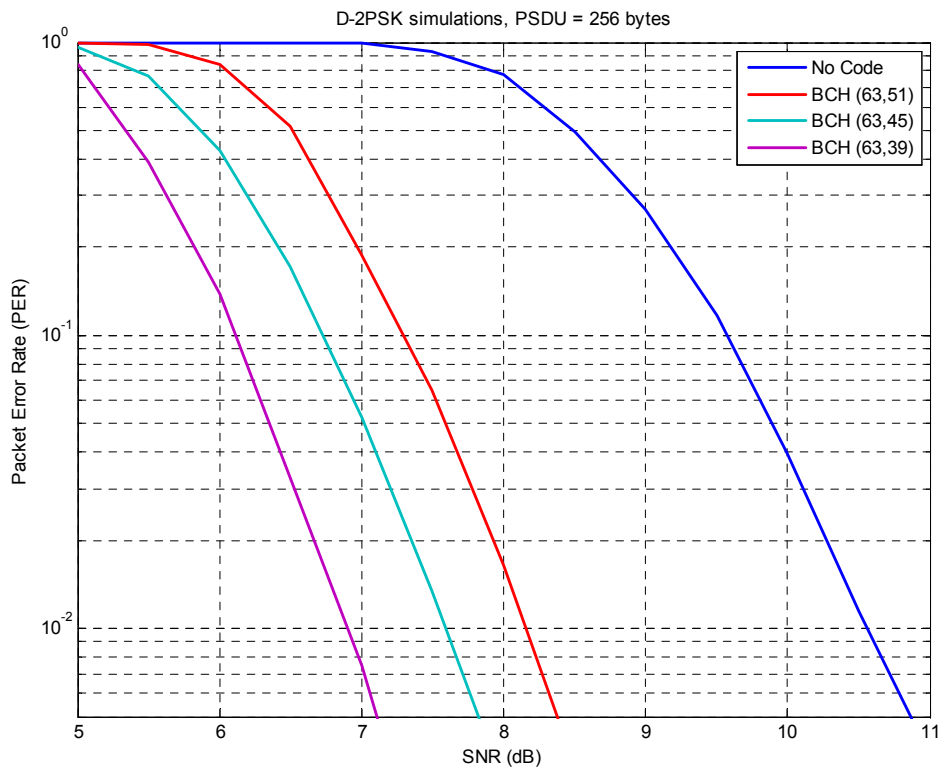

Packet Error Rate Curves (2)

- Assumptions: AWGN, zero carrier-frequency offset, ideal timing, PSDU = 256 bytes
- Constellation: $\pi/8$ -D8PSK

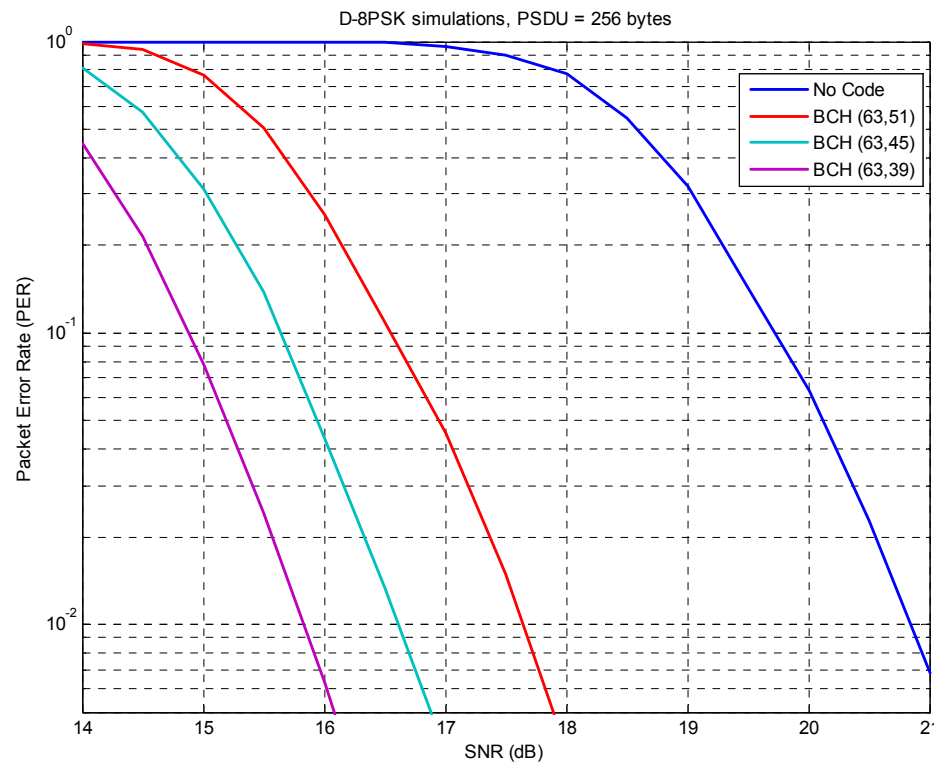

Link Budget and Receiver Sensitivity (1)

- Assumption: AWGN and 0 dBi gain at TX and RX antennas

Parameter	Value	Value	Value	Value	Value	Value	Value	Value
Data Rate (R_b) [kbps]	127.8	1022.6	127.8	766.9	154.8	607.1	101.2	303.6
Average TX Power (P_T) [dBm]: -10 dBm + backoff	-10.52	-11.20	-10.52	-11.81	-10.52	-11.56	-10.52	-11.56
TX Antenna Gain (G_T) [dBi]	0	0	0	0	0	0	0	0
Center Frequency (f_c) [MHz]	2480	2480	928	928	956	956	870	870
Distance Outside Body (d_1) [m]	3	3	3	3	3	3	3	3
Path Loss @ d_1 : ($L_1 = 20\log_{10}(4\pi df_c/c)$) [dB]	49.87	49.87	41.34	41.34	41.59	41.59	40.77	40.77
Rx Antenna Gain (G_R) [dBi]	0	0	0	0	0	0	0	0
RX Power: $P_R = P_T + G_T + G_R - L_1$ [dBm]	-60.39	-61.07	-51.86	-53.15	-52.11	-53.15	-51.29	-52.33
Avg. Noise Power: ($N = -174 + 10\log_{10}(BW)$) [dBm]	-114.40	-114.13	-117.41	-117.07	-118.42	-118.02	-121.45	-121.01
RX Noise Figure (N_F) [dB]	10	10	10	10	10	10	10	10
Total Noise Power ($P_N = N + N_F$) [dBm]	-104.40	-104.13	-107.41	-107.07	-108.42	-108.02	-111.45	-111.01
Minimum SNR (S) [dB] (PER = 10%)	2.80	11.20	4.80	16.50	6.10	16.50	7.30	16.50
Implementation Loss (I) [dB]	6	6	6	6	6	6	6	6
Link Margin ($M = P_R - P_N - S - I$) [dB]	35.20	25.86	44.75	31.42	44.21	32.36	46.86	36.17
Minimum RX Sensitivity ($P_S = P_R - M$) [dBm]	-95.60	-86.93	-96.61	-84.57	-96.32	-85.52	-98.15	-88.51

Link Budget and Receiver Sensitivity (2)

- Assumption: AWGN and 0 dBi gain at TX and RX antennas

Parameter	Value	Value
Data Rate (R_b) [kbps]	126.1	428.6
Average TX Power (P_T) [dBm]: -16 dBm includes backoff	-16.00	-16.00
TX Antenna Gain (G_T) [dBi]	0	0
Center Frequency (f_c) [MHz]	405	405
Path Loss Inside Body*	34	34
Distance Outside Body (d_1) [m]	3	3
Path Loss @ d_1 : ($L_1 = 20\log_{10}(4\pi df_c/c)$) [dB]	34.15	34.15
Rx Antenna Gain (G_R) [dBi]	0	0
RX Power: $P_R = P_T + G_T + G_R - L_1$ [dBm]	-84.15	-84.15
Avg. Noise Power: ($N = -174 + 10\log_{10}(BW)$) [dBm]	-119.96	-119.60
RX Noise Figure (N_F) [dB]	10	10
Total Noise Power ($P_N = N + N_F$) [dBm]	-109.96	-109.60
Minimum SNR (S) [dB] (PER = 10%)	6.70	16.50
Implementation Loss (I) [dB]	6	6
Link Margin ($M = P_R - P_N - S - I$) [dB]	13.11	2.94
Minimum RX Sensitivity ($P_S = P_R - M$) [dBm]	-97.26	-87.10

* A. J. Johansson, "Wireless communication with medical implants: Antenna and propagation," ISSN 1402-8662, 2004

Channel Fading Statistics

- Assumptions:
 - CM4 (on-body to external device)
 - Averaged over all orientations (0° , 90° , 180° , 270°)
 - Transmitter location: Chest
 - Action: Standing
 - Velocity = 1 km/hr
 - Removed free-space path loss ($\text{exp} = 2$) from channel gain*

Frequency Band (MHz)	90% Fade Depth at 3 meters	95% Fade Depth at 3 meters	99% Fade Depth at 3 meters
2360 – 2483.5	17.1 dB	17.5 dB	19.0 dB
902 – 928	18.8 dB	19.0 dB	19.5 dB
950 – 956	18.6 dB	18.7 dB	19.2 dB
863 – 870	19.4 dB	19.5 dB	20.0 dB

* Free-space path loss already accounted for in link budget table

System Performance

- Frequency bands: 2360 – 2483.5, 902 – 928, 950 – 956, 863 – 870 MHz
- Link margin analysis in realistic channel environments:

Parameter	Value	Value	Value	Value	Value	Value	Value	Value
Center Frequency (f_c) [MHz]	2480	2480	928	928	956	956	870	870
Data Rate (R_b) [kbps]	127.8	1022.6	127.8	766.9	154.8	607.1	101.2	303.6
AWGN Link Margin [dB]	35.2	25.9	44.8	31.4	44.2	32.4	46.9	36.2
99% Fade Depth at 3 meters	19.0	19.0	19.5	19.5	19.2	19.2	20.0	20.0
Link Margin [dB]	16.2	6.9	25.3	11.9	25.0	13.2	26.9	16.2

- *Sufficient margin to operate at even the highest data rate in realistic channel environments*

TX Mask and Spectrum

- TX spectral mask shall be less than -20 dB for $|f - f_c| \geq f_{BW} / 2$
- Example: Power spectral density for a 1022.6 kbps signal at 2400 MHz

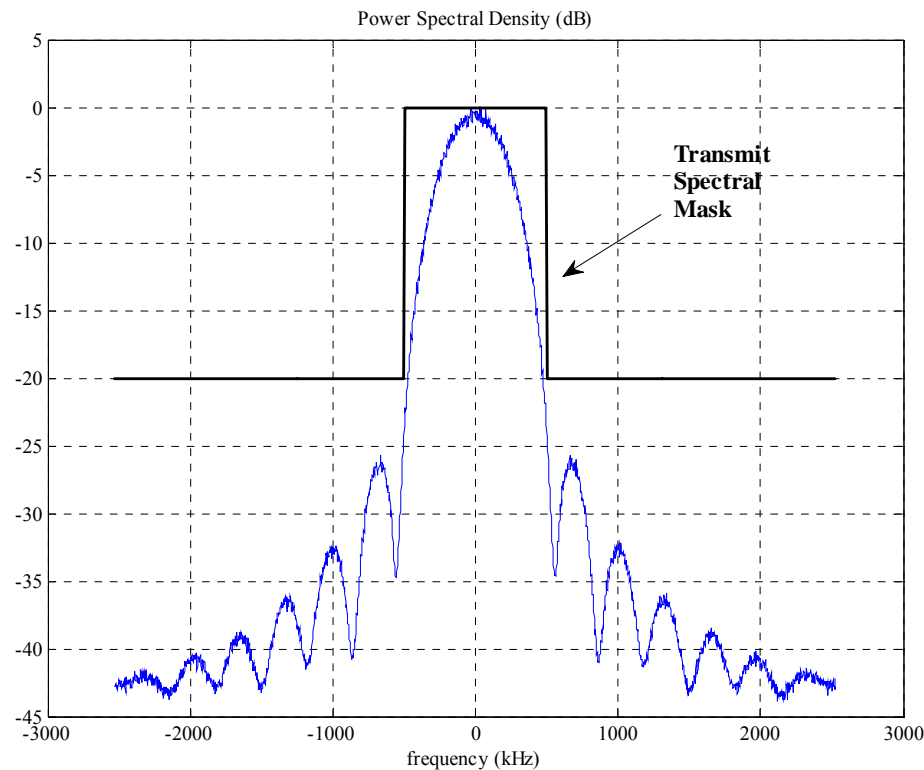

Sensitivity and ACI

Frequency Band (MHz)	Data Rate (kbps)	Minimum Sensitivity (dBm)	Adjacent Channel Rejection (dB)
2360 – 2483.5	1022.6	-86	7
902 – 928	766.9	-84	2
950 – 956	607.1	-85	2
863 – 870	303.6	-88	2
402 – 405	425.6	-87	2

- The adjacent channel rejection shall be measured by setting the desired signal's strength 3 dB above sensitivity for the highest data rate and raising the power of the interfering signal until 10% PER is caused for a PSDU length of 256 bytes. The power difference between the interfering and the desired channel is the corresponding adjacent channel rejection

Multiple Network Support

- Each of the proposed frequency bands supports a minimum of 10 channels:
 - 2400 – 2483.5 MHz: 79 channels
 - 2360 – 2400 MHz: 38 channels
 - 402 – 405 MHz: 10 channels
 - 902 – 928 MHz: 48 channels
 - 950 – 956 MHz: 12 channels
 - 863 – 870 MHz: 15 channels
- Multiple co-located networks can be supported via FDMA
- Maximum BAN deployment density is supported by a dedicated frequency spectrum (*proposed 2360 – 2400 MHz band in US*)
 - Band allows for large channel bandwidths (1 MHz) \Rightarrow sufficiently high data rates to support multiple medical applications

Signal Robustness and Coexistence

- Assumption: received signal is 6 dB above sensitivity.
- Value listed below are the required distance and frequency separation needed to obtain a $PER \leq 10\%$ for a PSDU = 256 byte.

Interferer	Value
IEEE 802.11g @ 2.4 GHz, $P_{tx} = +15$ dBm	$d_{int} \leq 8.0$ m (↓), $f_{sep} \geq 22$ MHz (↑)
Bluetooth @ 2.4 GHz, $P_{tx} = 0$ dbm	$d_{int} \leq 0.3$ m (↓), $f_{sep} \geq 2$ MHz (↑)

PHY-SAP Throughput

- Assumptions:
 - 2360 – 2483.5 MHz PHY parameters
 - MAC frame body length is 64 or 255 bytes
 - PSDU (MAC Header + MAC frame body + FCS) length is 73 or 265 bytes
 - SIFS = 20 μ s

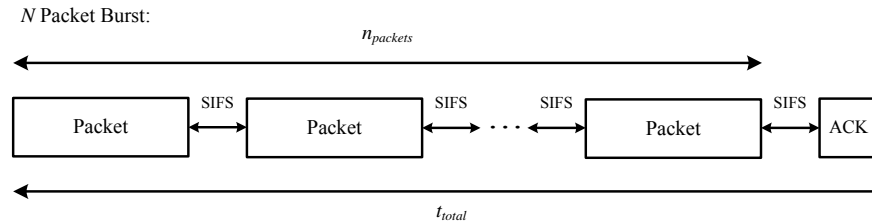
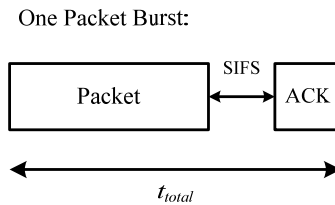

64 bytes:

Number of frames	Throughput @ 1000 kbps
1	399.3 kbps
5	523.7 kbps

255 bytes:

Number of frames	Throughput @ 1000 kbps
1	734.8 kbps
5	825.3 kbps

Complexity

- Manufacturability:
 - Process: low-voltage, low-leakage CMOS 90 nm technology node, which should be available before standard is complete
 - Solution will be built using a [standard CMOS technology](#)
- Time to market: solution would be ready when standard is available
- Size: solutions would support digital band-aids, medical devices, etc.
- Die Size at 90 nm: 2.5 mm² (analog + digital)
- External components:
 - Paper/coin battery, crystal (± 20 PPM), low-power timing crystal (eg. 32 kHz), two decoupling caps, pre-select filter, antenna

Power Consumption

- Power consumption (analog plus digital)*:

Frequency Band (MHz)	Data Rate (kbps)	TX	RX	Standby	Deep Sleep
2360 – 2483.5	1022.6	2.9 mW	3.1 mW	50 μ W	250 nW
902 – 928	733.1	2.2 mW	2.5 mW	50 μ W	250 nW
950 – 956	607.1				
863 – 870	303.6				
402 – 405	428.6	1.9 mW	2.1 mW	50 μ W	125 nW

*Assumptions: Analog = 1 V, Digital = 0.7 V and 1 V, -10 / -16 dBm output power
RF optimized for frequency band of operation

Comparison Criteria

Criteria	Proposed Capability
1. Regulatory	Compliant with TG6 regulatory document in multiple frequency bands
2. Raw PHY data rate	100 kbps to 1 Mbps supported between node and hub
3. Transmission distance	PER and link budget shown to support 10% PER for 255 octet PSDU at 3 meters within all operating frequency bands proposed.
4. Packet error rate	
5. Link budget	
6. Power emission level	-10 dBm / -16 dBm maximum EIRP
7. Interference and coexistence	MAC: Channel hopping, Beacon shifting, Acknowledgements, Poll/Post for additional retransmission if necessary. PHY: Channelization ≥ 10 channels, same channel bandwidth for all modulations at each frequency band, low sidelobes of selected modulation
8. Security	MAC provides 3 levels of security (none, authentication, authentication + encryption) based on AES-128. Association protocols provided for master key setup.
9. Reliability	Acknowledged traffic, guard time and node synchronization to beacon provided. Unique identifications used to distinguish between collocated BANs. Link margin sufficient given TG6 channel models variations.
10. Quality of Service	MAC: Time to join a network ~ 63 msec for message exchange. Fast (<1 sec) channel access available via prioritized CSMA/CA random access as well as scheduled or improvised access mechanisms.
11. Scalability	PHY: Scalable data rate from common symbol rates. MAC: Multiple nodes supported via m-periodic scheduled, improvised and random access methods. Prioritized QoS and beacon configuration.
12. MAC transparency	MAC transparent across multiple frequency bands proposed
13. Power Efficiency	MAC: Sleep and Hibernate modes. PHY: ≤ 3.1 mW (active), 50 μ W (standby), 250/125 nW (deep sleep)
14. Topology	Star topology, broadcast beacon supported. Maximum number of nodes supported via multiple access mechanisms.
15. Bonus Point	Merged proposal focused on satisfying needs of medical BAN applications as defined by TG6 PAR.

Summary

- PHY has been designed to be a very low-power, low-complexity solution
- PHY supports:
 - Scalable data rates from 100 – 1000 kbps
 - A minimum range of 3 meters
 - Multiple frequency bands
- Expected current consumption in a low-leakage, low-voltage 90 nm: ≤ 3 mA
- PHY can coexist with other BAN networks and other wireless technologies
- PHY complies with world-wide regulations
- MedWiN PHY offers the best trade-off between the various system parameters