

Project: IEEE P802.15 Working Group for Wireless Personal Area Networks (WPANs)**Submission Title:** MedWiN MAC and Security Proposal – Part 1 of 2**Date Submitted:** May 4, 2009**Source:** David Davenport⁽¹⁾, Neal Seidl⁽²⁾, Jeremy Moss⁽³⁾, Maulin Patel⁽⁴⁾, Anuj Batra⁽⁵⁾, Jin-Meng Ho⁽⁵⁾, Srinath Hosur⁽⁵⁾, June Chul Roh⁽⁵⁾, Tim Schmidl⁽⁵⁾, Okundu Omeni⁽⁶⁾, Alan Wong⁽⁶⁾

- (1) GE Global Research, davenport@research.ge.com, 518-387-5041, 1 Research Circle, Niskayuna, NY, USA
- (2) GE Healthcare, neal.seidl@med.ge.com, 414-362-3413, 8200 West Tower Avenue, Milwaukee, WI, USA
- (3) Philips, j.moss@philips.com, +44 1223 427530, 101 Cambridge Science Park, Milton Road, Cambridge UK
- (4) Philips, maulin.patel@philips.com, 914-945-6156, 345 Scarborough Road, Briarcliff Manor, NY, USA
- (5) Texas Instruments, {batra@ti.com, 214-480-4220}, {jinmengho@ti.com, 214-480-1994}, {hosur@ti.com, 214-480-4432}, {jroh@ti.com, 214-567-4145}, {schmidl@ti.com, 214-480-4460}, 12500 TI Blvd, Dallas, TX, USA
- (6) Toumaz Technology, {okundu.omeni@tomuaz.com, +44 1235 438950}, {alan.wong@toumaz.com, +44 1235 438961}, Building 3, 115 Milton Park, Abingdon, Oxfordshire, UK

Re: Response to IEEE 802.15.6 call for proposals**Abstract:** This presentation illustrates the major MAC aspects of a joint MAC and security proposal detailed in an accompanying normative text document doc. IEEE 802.15-09-0327-00-0006.**Purpose:** To submit a joint proposal on MAC and security to the IEEE 802.15.6 task group**Notice:** This document has been prepared to assist the IEEE P802.15. It is offered as a basis for discussion and is not binding on the contributing individual(s) or organization(s). The material in this document is subject to change in form and content after further study. The contributor(s) reserve(s) the right to add, amend or withdraw material contained herein.**Release:** The contributors acknowledge and accept that this contribution becomes the property of IEEE and may be made publicly available by P802.15

MedWiN MAC and Security Proposal

Part 1 of 2 – MAC Sublayer

GE Global Research: David Davenport

GE Healthcare: Neal Seidl

Philips: Jeremy Moss, Maulin Patel

Texas Instruments: Anuj Batra, Jin-Meng Ho
Srinath Hosur, June Chul Roh
Tim Schmidl

Toumaz Technology: Okundu Omeni, Alan Wong

Outline

- Network topology
- Scalable access mechanisms
 - Time partitioning and beacon transmission
 - Addresses and IDs
 - Scheduled access (one-periodic & multi-periodic allocations)
 - Improvised access (polls & posts)
 - Random access (CSMA/CA contention)
- Joining a Body Area Network
- Reliability and QoS
 - Acknowledgement policies
 - Urgent alarm access (<1 sec)
- Interference and Coexistence
- Power efficiency
- Implementation estimates
- Summary

Centralized, Star Network Topology

- Enable Medical Body Area Network (BAN) applications
- Support simple, effective access methods
- Reduce network management overhead & power consumption
- Simplify creation of a secure network

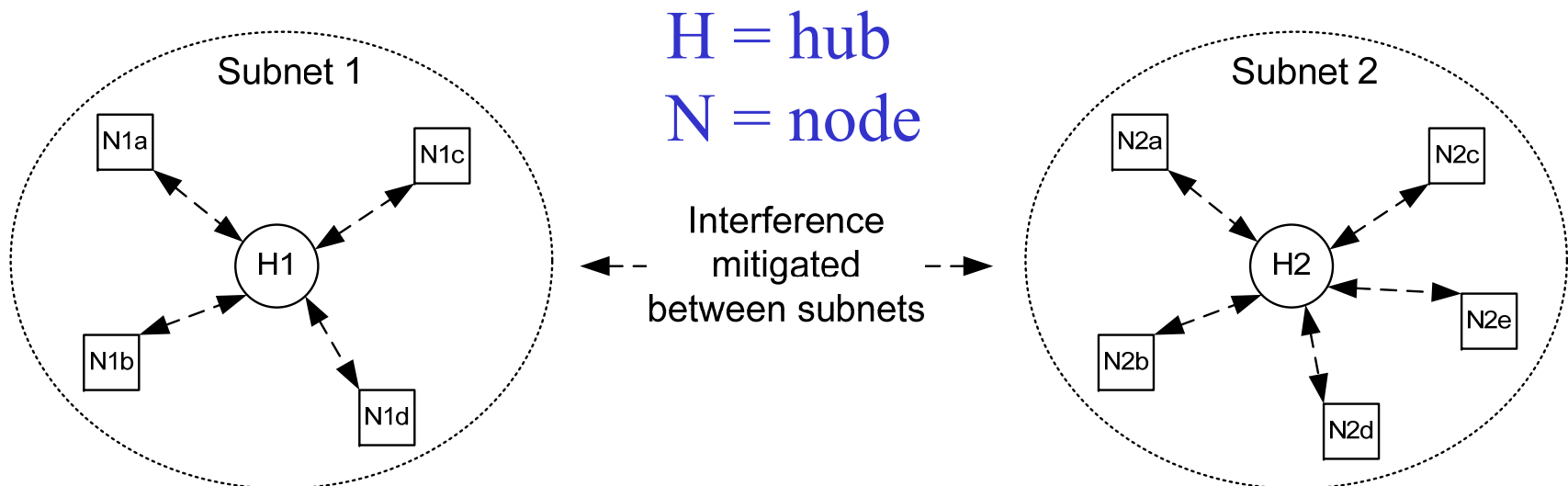

Time Partitioning and Beacon Transmission

- Beacon period
 - Hub transmits beacon every period
 - Length = $4N$ allocation slots, N determined by hub
 - Maximum $4N = 256$ allocation slots
- Allocation slot
 - Slot length determined by hub
 - Slot length 1 to 256 msec
 - Time units for access intervals
- Allocation interval
 - Consecutive allocation slots (≥ 1 slot)
 - Interval length determined by hub or negotiated with node

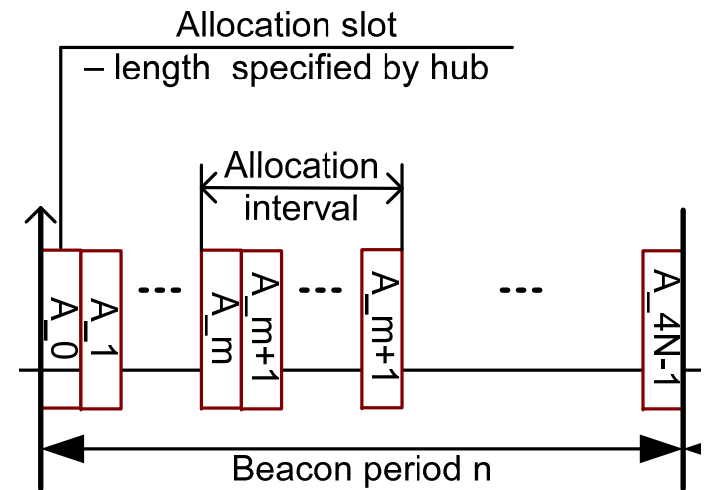

Addresses and IDs

- Every device assigned 48 bit address at manufacture
 - Uniquely identifies each node and hub
 - Exchanged in management frames to unambiguously identify connecting devices
- Abbreviated addresses Identifier exchanged in MAC header of all frames
 - Hub uses lowest 16 of 48 bit address as its HID
 - $2^{16} = 65,536$ HIDs sufficient for hospital environment
 - Node assigned its 8 bit NID by hub at connection
 - MAC header requires only 7 bytes

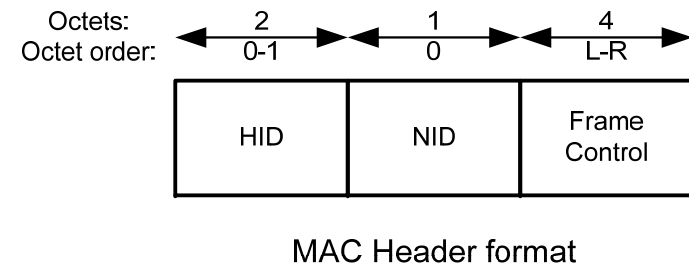
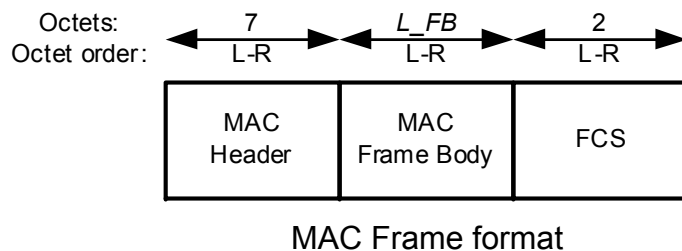

Medical Body Area Network Access

- **Medical application requirements**
 - Continuous patient monitoring needs periodic, deterministic access for bounded latency and loss
 - Home and other environments need infrequent, robust access for episodic data traffic
 - Sensor node type, quantity change over time for a patient
- **Access mechanisms supported**
 - Scheduled access (1-periodic, m-periodic allocations)
 - Improvised access (polls & posts)
 - Random access (CSMA/CA contention)

Scheduled Access

Enables continuous and periodic medical patient monitoring

- Mandatory for hub, optional for node
- Node or hub obtains one or more recurring allocation intervals to initiate frame transactions
 - 1-periodic: allocation interval in every beacon period
 - m-periodic: allocation interval every multiple beacon periods
 - Single allocation interval may be shared among several m-periodic nodes
 - Allocation interval includes acknowledgements
- Scheduled access enables periodic
 - Hub to node downlink traffic
 - Node to hub uplink traffic
- Requested by node's Connection Request frame
- Granted via hub's Connection Assignment frame

Scheduled Access (2)

B = beacon BP = beacon period
 A1 = 1-periodic allocation interval of node 1 T1 = interval start of A1 relative to beacon transmission time

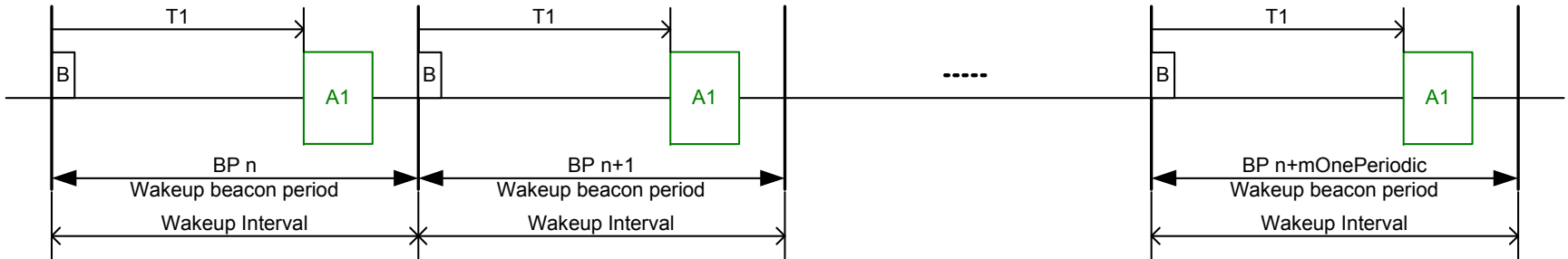

(a) 1-periodic allocation of node 1

B = beacon BP = beacon period
 A2 = m-periodic allocation interval of node 2 T2 = interval start of A2 relative to beacon transmission time

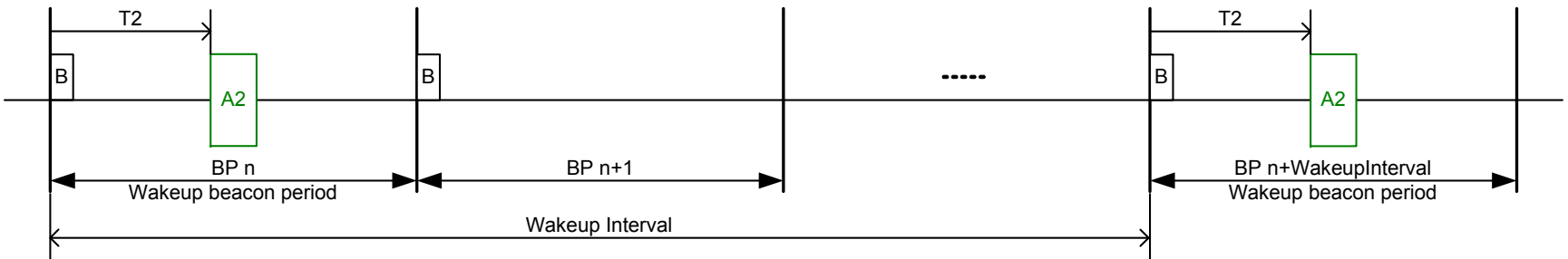

(b) m-periodic allocation of node 2

Improvised Access

Enables impromptu exchange for medical alarms, variable data quantities, configuration and network construction

- Improvised access yields allocation interval for a single beacon period
 - Short-distance: improvised allocation immediately following
 - Long-distance: improvised allocation later in the beacon period
 - Allows node to sleep and save power within beacon period
- Hub with data for a node
 - Essential for network management
 - Informs node of pending Post via Acknowledgement frame
 - Post: hub to node (Mandatory for hub and node)
- Node needs bandwidth beyond its scheduled allocation
 - Requests Poll with More Data bit in MAC header frame control field
 - If short-distance: Acknowledgement + Poll sent to allow node to continue
 - If long-distance: Poll frame sent by hub to indicate start of improvised interval
 - Poll: node to hub (Optional for hub and node)

Improvised Access (2)

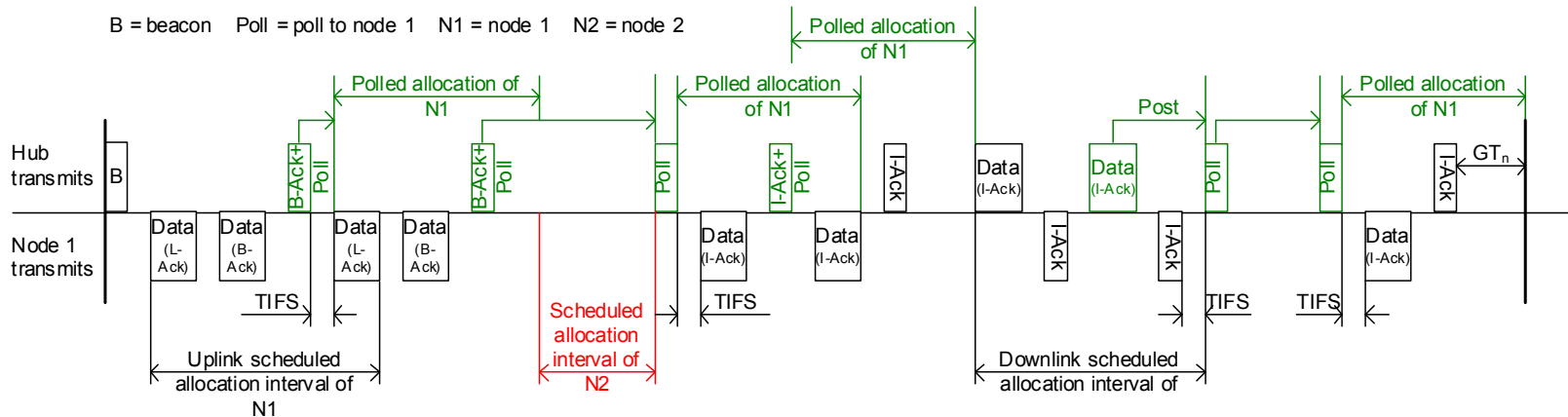

Example Polls and Polled Allocations

Improvised Access (3)

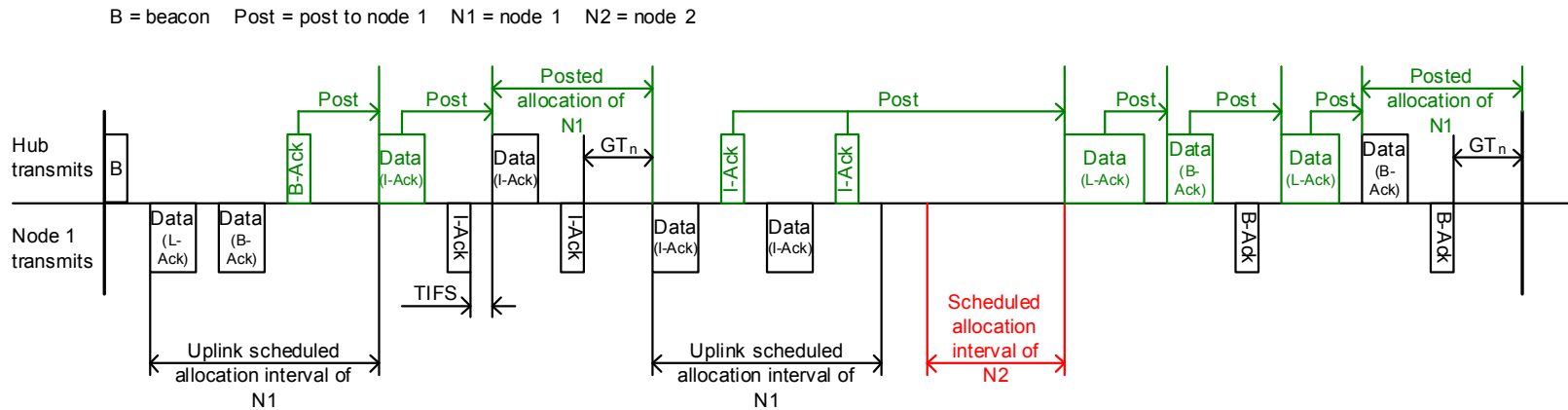

Example Posts and Posted Allocations

Improvised Access (4)

Frames and fields sent by a hub enabling polls and posts

	Short distance	Long distance
Poll	<p>Poll, I-Ack+Poll, or B-Ack+Poll frame, with More Data = 0, Sequence Number = A, Fragment Number = <i>Reserved</i> :</p> <p>A polled allocation starts TIFS after the end of the current frame, and ends at the end of allocation slot A located in the current beacon period.</p>	<p>Poll, I-Ack+Poll, or B-Ack+Poll frame, with More Data = 1, Sequence Number = A, Fragment Number = B :</p> <p>No polled allocation follows this frame, but another poll starts at the start of allocation slot A located in the current beacon period if $B = 0$ or in the next Bth beacon period if $B > 0$.</p>
Post	<p>Non-beacon management or data type frame, with More Data = 1 :</p> <p>A post starts TIFS after the end of the current frame transaction. A poll providing another poll but not a polled allocation may be considered a post.</p>	<p>I-Ack or B-Ack frame, with More Data = 1, Sequence Number = A, Fragment Number = B :</p> <p>A post starts at the start of allocation slot A located in the current beacon period if $B = 0$ or in the next Bth beacon period if $B > 0$.</p>

Random Access

Enables episodic medical applications like home and fitness monitoring, medical alerts and alarms

- Hub's beacon advertises two random access phases within the beacon period
 - First phase immediately after beacon (RAP1)
 - Second phase at half beacon interval (RAP2)
 - Width of random access phases specified by RAP1 and $RAP2 \geq 0$ slots
- Mandatory for hub
 - Hub has to listen only, does not need to perform CSMA/CA
 - RAP1 and RAP2 can be set to zero, effectively disabling Random Access
- Random access support is optional for node

Random Access (2)

- Random Access based on CSMA/CA
 - If enabled ($RAP > \text{zero}$), minimum value of $RAP1$ provided via Connection Assignment
 - $RAP1$ can be larger, but no smaller than L
 - $RAP2$ can be any size including zero
 - Hub can vary width of $RAP1$ and $RAP2$ across beacon periods

B = beacon BP = beacon period L = Minimum $B+RAP1$ Length

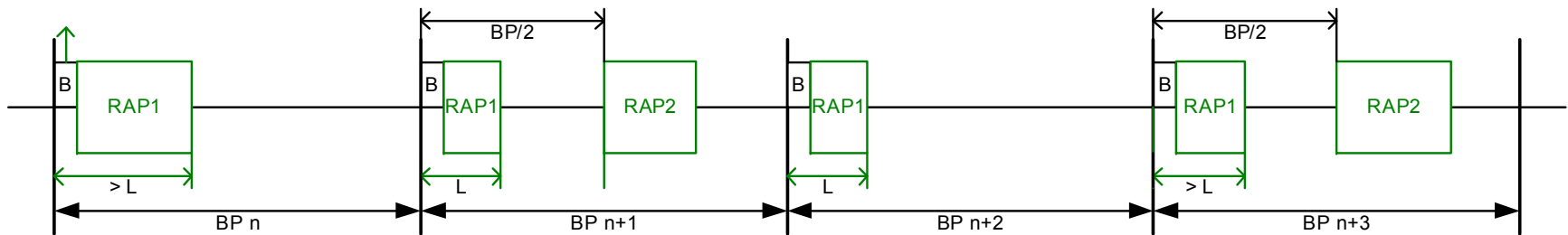

Random access phases (RAPs)

Random Access (3)

- A node sets a back-off counter to a random integer in $[1, CW]$, with $CW_{min} \leq CW \leq CW_{max}$, to obtain a contended allocation for one or more frame transactions.
- Alternative doubling of contention window with every other failure; redraw back-off on each failure

B = beacon A2 = scheduled allocation of node 2 RAPn = random access phase (RAP) n Slot = contention slot
 F1 = frame transaction initiated by node 1 in a contended allocation Tf = time required to complete F1 GT_n = nominal guard time

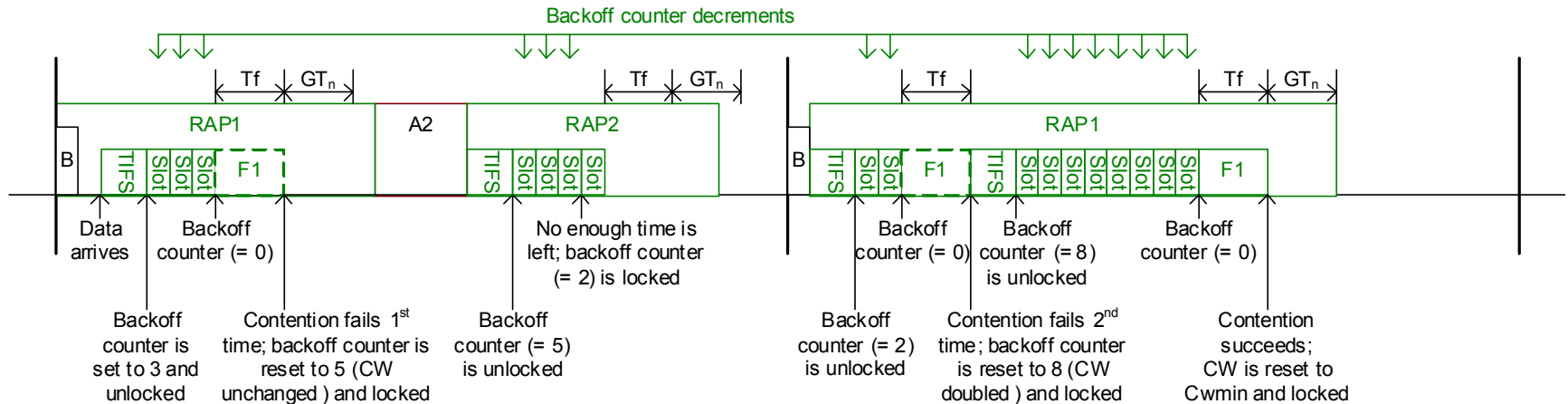

Random access by node 1 to obtain a contended allocation

Joining a Body Area Network

- Node to join a network
 - Node must scan to find a Hub’s beacon frame or Unconnected poll frame
 - Node can leverage Random Access or Improvised Access to join

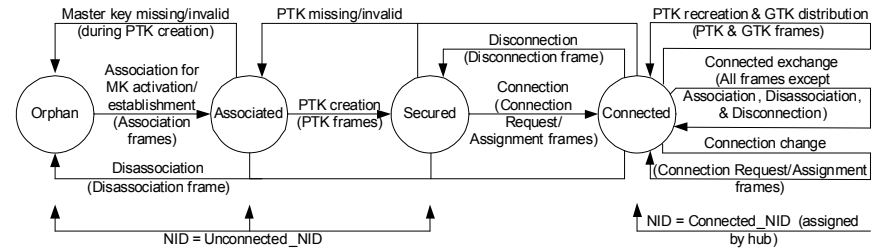

(a) Secured Communication

- Node joins via secure or unsecured access mechanisms
 - **Association:** identify node and hub to each other, establish or activate a master key
 - **Connection:** relationship between node and hub in the same subnet, substantiated by a Connected_NID assigned to the node by the hub, and by a power management profile and an access allocation contract negotiated between the node and the hub.

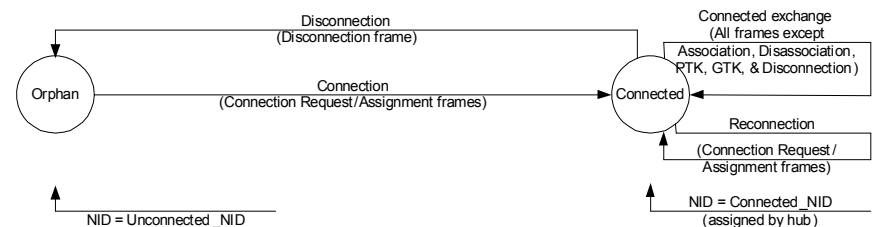

(b) Unsecured Communication

Access State Diagram

Joining a Body Area Network (2)

- Node to join a network – using Improvised Access
 - Hub provides unconnected poll allocations to Unconnected Broadcast NIDs
 - Node selects an Unconnected NID and sends its first frame to hub in the improvised poll allocation
 - If successful, hub assigns the node a new NID and new, unicast, improvised polls until Connection Request frame received
 - If no acknowledgement from hub, node retries in subsequent unconnected poll allocations with probability = $\min(1/4, 1-R/4)$, R = retry number

- Node to join a network – using Random Access
 - Node scans for hub's beacon frame
 - Node supports CSMA/CA and hub advertises RAP1 or $RAP2 > 0$
 - Node contends for access for its first frame to hub using an Unconnected NID
 - If successful, hub assigns the node a NID and new, unicast, improvised polls until Connection Request frame received

Joining a Body Area Network (3)

- Hub configuration
 - Determines slot availability for Association and Connection frames
 - Contributes to node scan time given channel hopping, beacons interval and use of Unconnected broadcast Polls
- Illustrative examples of frames exchanged to join a network
 - Case 1: 863 – 870 MHz band with 125 ksps symbol rate, 64.5 kbps PHY header information rate and 101.2 kbps data information rate
 - Case 2: 2360 – 2483.5 MHz band with 631.58 ksps symbol rate, 81.5 kbps PHY header information rate and 1022.6 kbps data information rate
 - Transfer time/Frame = $(8 \cdot \text{MAC Octets}/\text{Info Rate}) + (16 \text{ bits}/\text{Header Info Rate}) + (72 \text{ bits}/\text{Symbol Rate})$
 - Excludes time to perform key computations

Join Mode	Frames Required	MAC octets	Transfer Time Case 1	Transfer Time Case 2
Unsecured Connection	Connection Request* + I-ACK	48 + 9	10.73 msec	2.07 msec
	Connection Assignment* + I-ACK	40 + 9		
Secured Association & Connection	3 (Master Key Association + I-ACK)	3 (103 + 9)	62.67 msec	9.86 msec
	3 (PTK Creation + I-ACK)	3 (47 + 9)		
	Connection Request* + I-ACK	56 + 9		
	Connection Assignment* + I-ACK	48 + 9		

* Assumes 1 uplink and 1 downlink scheduled allocation for node

Reliability and Quality of Service

Reliable communications is essential for streaming and episodic medical data exchange given bounded data loss and latency requirements

- Acknowledgement policies support application reliability and latency
 - Immediate Acknowledgement (I-Ack) of preceding frame
 - Block Acknowledgement (B-Ack) of multiple, preceding frames allows for selective retransmission when burst of frames is sent
 - Either Ack message may include Poll allocation grant for the node
- Urgent alarm access (<1 sec) possible via two access methods
 - Improvised access permits conveyance of data outside of scheduled allocations to satisfy latency constraints
 - Node may send data and alarms
 - Hub may send configuration or response to a node
 - Random access with Quality of Service prioritization

Acknowledgment Policy

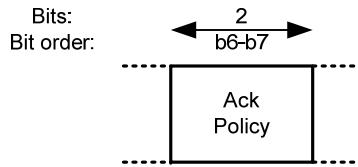

Included in Frame Control field of MAC header

Table — Acknowledgment (Ack) Policy field encoding

Field value b6 b7	Acknowledgment requirement
00	No acknowledgment (N-Ack)
10	Immediate acknowledgment (I-Ack)
11	Block acknowledgment later (L-Ack)
01	Block acknowledgment (B-Ack)

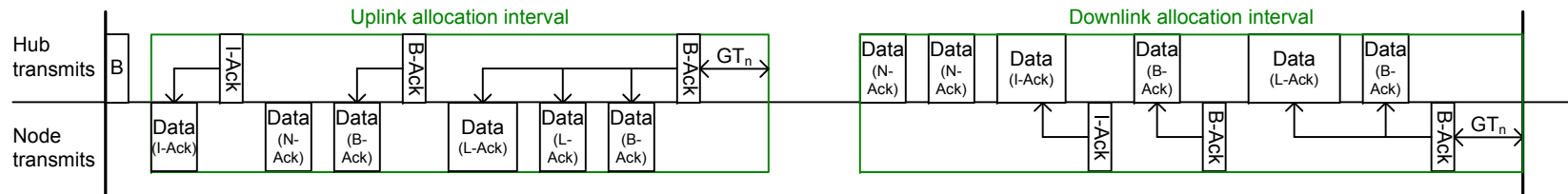

Transmissions in uplink and downlink allocation intervals

Random Access – Prioritization

CWmin and CWmax values

Priority	User Priority	Traffic designation	CWmin	CWmax
	0	t.b.d.	16	64
	1	t.b.d.	16	32
	2	t.b.d.	8	32
	3	t.b.d.	8	16
	4	t.b.d.	4	16
	5	t.b.d.	4	8
	6	t.b.d.	2	8
	Highest	7	Emergency message	1

Coexistence and Interference Mitigation

Medical use cases involve many collocated patients, each with their own BAN, and other radio services. Medical BANs require effective coexistence and interference mitigation.

- Coexistence among uncoordinated BANs
 - Collocated BANs do not synchronize amongst each other or via an infrastructure
 - Channel hopping and beacon shifting are mandatory for hub and node
- Channel Hopping of each BAN enables frequency diversity
 - Random frequency hopping, uniformly across available channels
 - Minimum frequency separation based on channel coherence bandwidth
- Beacon Shifting of each BAN in time domain enables temporal diversity
 - Dithering of beacon message transmission among 4 quarters of beacon period
 - Cyclical shift of activity within the beacon period

Coexistence and Interference Mitigation (2)

- Channel Hopping of each BAN enables frequency diversity
 - Hub generates channel hop sequence using linear feedback shift register (LFSR)
 - Least significant 16 bits of hub MAC address used to initialize LFSR
 - Beacon messages contain LFSR status and indication of imminent change
 - LFSR mapped to channel ensuring equal probability selection and minimum frequency separation
 - Hub dwells on current channel for fixed number of beacon periods
 - Connection Assignment contains dwell length and phase
 - Can be disabled for single frequency channel operation

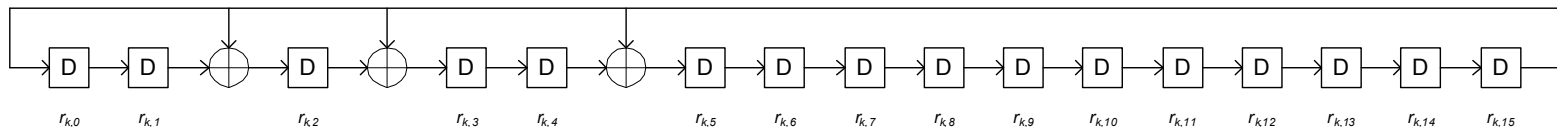

16-bit Galois LFSR for channel hopping sequence generation

Coexistence and Interference Mitigation (3)

- Beacon Shifting of each BAN in time domain
 - Hub selects a PN sequence $PN_m(n)$ to shift its beacon transmission time across beacon periods
 - A hub may choose $PN_0(n) = 0$ to transmit its beacon period start
 - Beacon message contains shifting sequence index and phase for the next period
 - Use of quarter beacon period fixed offsets simplifies implementation

B = beacon BP = beacon period
 BTTO = beacon transmission time offset
 BPST = beacon period start time

$PN_0(n) = 0, 0, 0, 0, \dots$; $PN_1(n) = 0, 1, 0, 1, \dots$; $PN_2(n) = 0, 2, 0, 2, \dots$;
 $PN_3(n) = 0, 1, 2, 3, \dots$; $PN_4(n) = 0, 1, 3, 2, \dots$; $PN_5(n) = 0, 2, 1, 3, \dots$;
 $PN_6(n) = 0, 2, 3, 1, \dots$; $PN_7(n) = 0, 3, 1, 2, \dots$; $PN_8(n) = 0, 3, 2, 1, \dots$;

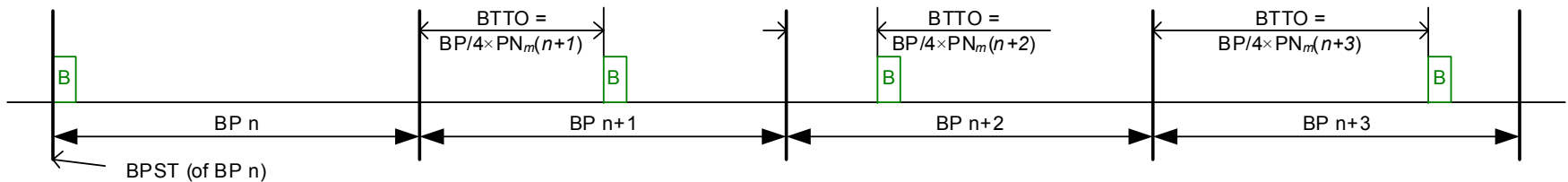

Beacon transmission with shifting sequence $PN_5(n) = 0, 2, 1, 3$

Coexistence and Interference Mitigation (4)

B_n = beacon transmitted by subnet of node n BP = beacon period
 A_n = 1-periodic allocation interval of node n T_n = interval start of A_n relative to beacon transmission time $T_n = T_{n-1} + T_{n-2}$

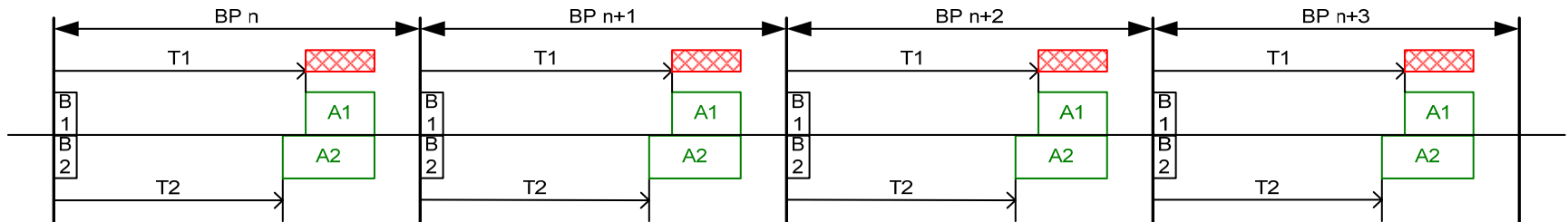

(a) Subnet of node 1: $PN_0(n) = 0, 0, 0, 0, \dots$; subnet of node 2: $PN_0(n) = 0, 0, 0, 0, \dots$

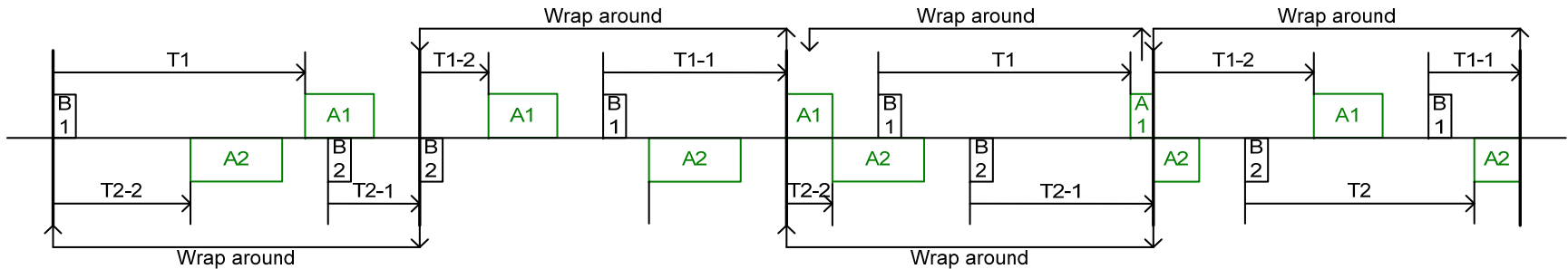

(b) Subnet of node 1: $PN_5(n) = 0, 2, 1, 3, \dots$; subnet of node 2: $PN_5(n-1) = 3, 0, 2, 1, \dots$

Beacon shifting to mitigate interference between BANs

Coexistence and Interference Mitigation (5)

Support for 10 BANs in 6 by 6 by 6 meter volume

- Proposed PHY affords at least 10 channels in each frequency band

Frequency Band (MHz)	Relationship between f_c and n_c
2400 – 2483.5	$f_c = 2402.00 + 1.00 \times n_c$ (MHz), $n_c = 0, \dots, 78$
2360 – 2400	$f_c = 2362.00 + 1.00 \times n_c$ (MHz), $n_c = 0, \dots, 37$
402 – 405	$f_c = 402.15 + 0.30 \times n_c$ (MHz), $n_c = 0, \dots, 9$
902 – 928	$f_c = 903.50 + 0.50 \times n_c$ (MHz), $n_c = 0, \dots, 47$
950 – 956	$f_c = 951.10 + 0.40 \times n_c$ (MHz), $n_c = 0, \dots, 11$
863 – 870	$f_c = 865.60 + 0.20 \times g(n_c)$ (MHz), $n_c = 0, \dots, 14$

$$g(n_c) = \begin{cases} n_c & 0 \leq n_c \leq 9 \\ n_c + 3 & 10 \leq n_c \leq 11 \\ n_c + 4 & 12 \leq n_c \leq 13 \\ n_c + 7 & n_c = 14 \end{cases}$$

- Channel hopping distributes probability of collision across channels
- Beacon shifting distributes probability of temporal collisions across a BAN's nodes
- Acknowledgements and improvised access provide for retransmission due to collisions as well as channel impairments
- Maximum BAN deployment density supported by dedicated frequency spectrum with sufficient bandwidth for channelization and retransmissions when needed (*proposed 2360-2400 MHz band for USA*)

Enabling MedRadio / MICS

Proposal provides tools to enable MedRadio applications

- Star topology suitable for implant to programmer permitted communications
 - Channelization plan based on 300 kHz bandwidth
- Frequency monitoring per FCC 95.628
 - Utilize MedWiN's proposed PHY energy detection and clear channel assessment
 - Disable channel hopping for single channel operation
- Simple, exemplary scenarios leveraging proposed access methods
 - Monitoring of MedRadio device within 402-405 MHz
 - Hub performs frequency monitoring (PHY ED, CCA), selects primary channel, disables channel hopping and defines an appropriate beacon period and slots
 - Hub transmits beacon message and Unconnected Polls for unconnected NIDs.
 - Node joins BAN, exchanges data and disconnects, ending the MedRadio communication session
 - Event alert from MedRadio device
 - FCC 95.1209(b) permits implants to transmit given medical implant event absent programmer.
 - Node joins hub as previous example, ends MedRadio communication session then sleeps
 - Hub monitors the previous channel for a future event, leveraging random access phase to avoid inefficient messages over the air

Power Management

Medical applications require power efficiency for battery operated devices

- Hibernation—macroscopic power management
 - Across beacon periods
 - Synchronization interval (SI_n) determined by system parameters and beacon's allocation slot length
 - Minimum allocation slot length (1msec), $SI_n = 1.5$ seconds
 - Maximum allocation slot length (256 msec), $SI_n = 639$ seconds
 - Node negotiates its wakeup interval with a hub through Connection Request
 - Independent of whether scheduled allocation is desired by node
- Sleep—microscopic power management
 - Within beacon period
 - A node may trade power for access by supporting polls and posts
 - Hub and nodes may sleep outside their scheduled, posted, and polled allocations, all of which have their time known to the nodes in advance

Power Management (2)

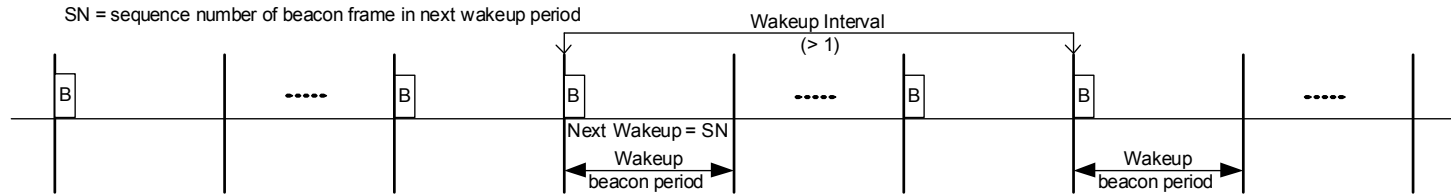

Example: Hibernation

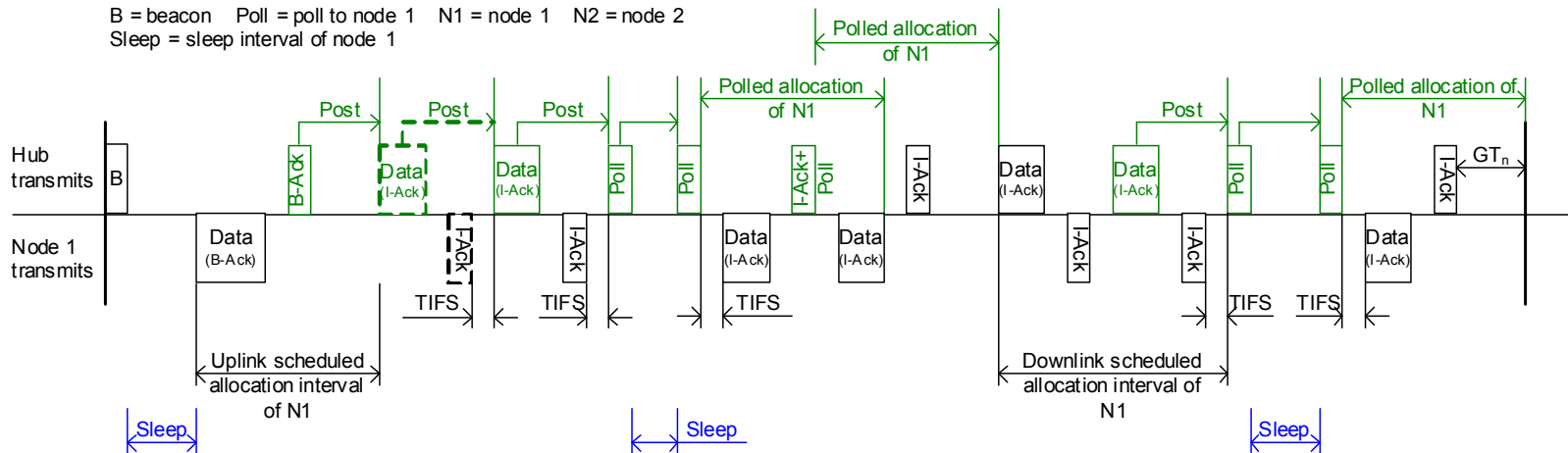

Example: Sleep for a node engaged in scheduled, post and poll allocations

Complexity

- Solution size would support digital band-aids, medical devices, etc.
 - Solution will be built using a standard CMOS technology
 - Die size estimates
 - Assumption: Hub supporting 16 nodes
 - Memory implemented as registers
- MAC clock
 - Accuracy of 20 ppm, Resolution of 10 usec
 - Two crystal option allows lower power Hibernation
- Power consumption estimates (minimum implementation)
 - Assumptions: Analog = 1 V, Digital = 0.7 V and 1 V

Device	Gate Count (kgates)
Hub minimum	80
Hub maximum	160
Node minimum	40
Node maximum	120

Device	@ 125 kbps	@ 1 Mbps	Standby	Hibernate (radio XTAL)	Hibernate (32 kHz watch XTAL)
Node	35 uW	280 uW	50 uW	50 uW	< 5 uW
Hub	70 uW	320 uW	50 uW	50 uW	< 5 uW

Enabling Low Power Operation

Illustrative example: Continuous monitoring of patient parameter, moderate data rate sensor node

- Assumed BAN configuration:
 - Beacon period = 80 msec with 40 allocation slots, each of 2 msec width
 - Beacon uses one allocation slot, Node uses one slot for scheduled uplink (1-periodic)
 - Operation at 1 Mbps within 2360-2483.5 MHz band affords 25,000 bps (raw)
 - Node receives for 2 msec, transmits for 2 msec sleeps 76 msec each beacon period
- Average power estimated as:

















$$\begin{aligned}
 P_{\text{Avg Node}} &= (T_{\text{sleep}}/T_{\text{beacon period}}) * (P_{\text{MAC Standby}} + P_{\text{PHY Standby}}) + (T_{\text{transmit}}/T_{\text{beacon period}}) * (P_{\text{MAC Active}} + P_{\text{PHY Tx}}) + (T_{\text{receive}}/T_{\text{beacon period}}) * (P_{\text{MAC Active}} + P_{\text{PHY Rcv}}) \\
 &= (76 \text{ msec} / 80 \text{ msec}) * (50 \text{ uW} + 50 \text{ uW}) + (2 \text{ msec} / 80 \text{ msec}) * (280 \text{ uW} + 2.9 \text{ mW}) + (2 \text{ msec} / 80 \text{ msec}) * (280 \text{ uW} + 3.1 \text{ mW}) \\
 &= (0.95) * (100 \text{ uW}) + (0.025) * (3.18 \text{ mW}) + (0.025) * (3.38 \text{ mW}) \\
 P_{\text{Avg Node}} &= 259 \text{ uW}
 \end{aligned}$$

- Compatible with lithium, zinc air batteries and possibly thin film power sources
 - Estimated > 300 hours operation at 1V with CR2016 lithium coin cell (3V, 80 mAh)
 - Estimated > 170 hours operation at 1V with Power Paper STD-2 battery (1.5 V, 30 mAh), [<http://www.powerpaper.com/index.php?categoryId=33408>]

Refer to PHY power consumption values from doc. IEEE 802.15-09-0328-00-00006.

MedWiN MAC Proposal Enables Medical and Consumer Applications per TG6 PAR

Illustrative examples – not a comprehensive list

Application Area - Use Case	PHY Frequency Bands and Data Rates	Scheduled Access Mechanism	Improvised Access Mechanism	Random Access Mechanism
Medical Applications – Continuous Patient Monitoring <i>physiological waveforms, vital signs, location, body motion and posture, etc.</i>				
Medical Application – Episodic Home Monitoring <i>weight scale, blood pressure, fall and impact, environment and context sensing, etc.</i>				
Consumer Application – Entertainment & Gaming <i>Streaming audio, visual with controller response input</i>				
Consumer Application – Social Interaction & Networking <i>Friend finder, business card exchange, etc.</i>				

Key: Enabling applicability  HIGH  MEDIUM  LOW

MedWiN MAC Proposal Summary

- Star topology – suitable to medical applications
- Time partitioning – simple but adjustable time slot structure
- Beacon – network management and interference mitigation
- Channel migration – frequency diversity & interference mitigation
- Access methods – flexible, scalable reservation & contention
 - Scheduled access (1-periodic & multi-periodic allocations)
 - Improvised access (polls & posts)
 - Random access (CSMA/CA contention) with priorities
- Acknowledgment policy – versatile but simple
- Power management – for both within and across beacon periods
- MAC frame structure – simple, effective header and body
- Frame types & subtypes – orthogonal, effective

Details are provided in the accompanying normative text doc. IEEE 802.15-09-0327-00-00006.

Comparison Criteria

Criteria	Proposed Capability
1. Regulatory	Compliant with TG6 regulatory document in multiple frequency bands
2. Raw PHY data rate	100 kbps to 1 Mbps supported between node and hub
3. Transmission distance	PER and link budget shown to support 10% PER for 255 octet PSDU at 3 meters within all operating frequency bands proposed.
4. Packet error rate	
5. Link budget	
6. Power emission level	-10 dBm / -16 dBm maximum EIRP
7. Interference and coexistence	MAC: Channel hopping, Beacon shifting, Acknowledgements, Poll/Post for additional retransmission if necessary. PHY: Channelization ≥ 10 channels, same channel bandwidth for all modulations at each frequency band, low sidelobes of selected modulation
8. Security	MAC provides 3 levels of security (none, authentication, authentication + encryption) based on AES-128. Association protocols provided for master key setup.
9. Reliability	Acknowledged traffic, guard time and node synchronization to beacon provided. Unique identifications used to distinguish between collocated BANs. Link margin sufficient given TG6 channel models variations.
10. Quality of Service	MAC: Time to join a network ~ 63 msec for message exchange. Fast (< 1 sec) channel access available via prioritized CSMA/CA random access as well as scheduled or improvised access mechanisms.
11. Scalability	PHY: Scalable data rate from common symbol rates. MAC: Multiple nodes supported via m-periodic scheduled, improvised and random access methods. Prioritized QoS and beacon configuration.
12. MAC transparency	MAC transparent across multiple frequency bands proposed
13. Power Efficiency	MAC: Sleep and Hibernate modes. PHY: ≤ 3.1 mW (active), 50 μ W (standby), 250/125 nW (deep sleep)
14. Topology	Star topology, broadcast beacon supported. Maximum number of nodes supported via multiple access mechanisms.
15. Bonus Point	Merged proposal focused on satisfying needs of medical BAN applications as defined by TG6 PAR.

Bonus Material

Beacon Transmission

Hub transmits beacon message each beacon period

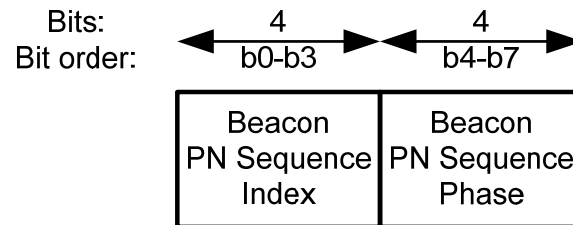
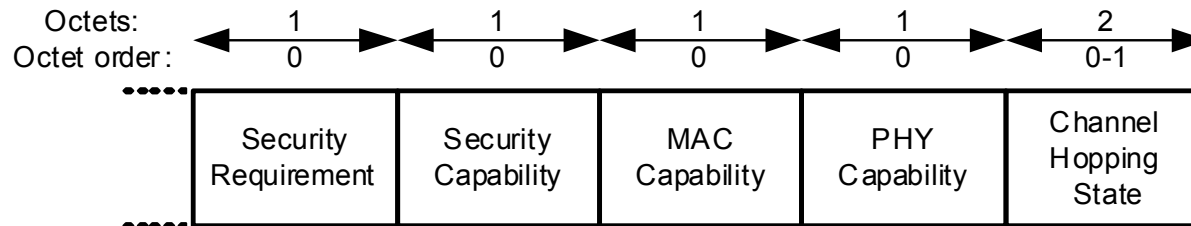
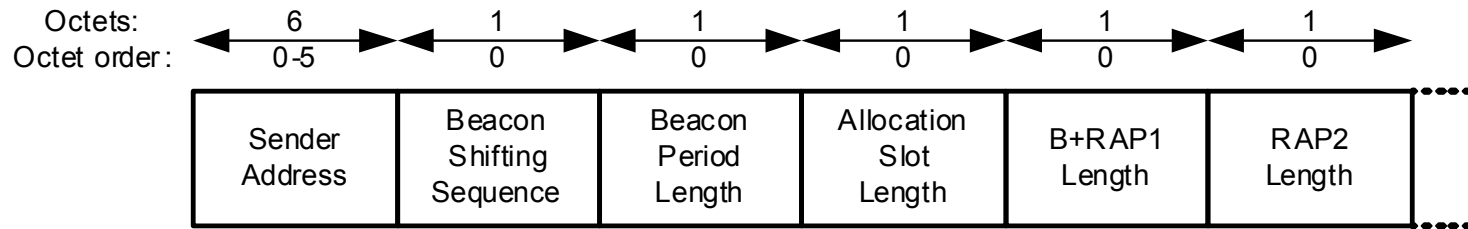

Beacon PN Sequence format

Clock Synchronization & Guard Time Provisioning

- All nodes synchronize to their hub through the beacons or the first frames in their scheduled allocation intervals received from the hub.
- Guard times are set aside at the start and/or end of each allocation interval.
- Synchronization interval (SIn) determined by system parameters and beacon's allocation slot length
 - Minimum allocation slot length (1msec), SIn = 1.5 seconds
 - Maximum allocation slot length (256 msec), SIn = 639 seconds
 - See MAC sublayer parameters
 - $mGT_Nominal = \text{Allocation Slot Length} / 10$
 - $mClockAccuracy = 20 \text{ ppm}$
 - $mClockResolution = 10 \text{ usec}$
 - $mSyncResolution = 10 \text{ usec}$

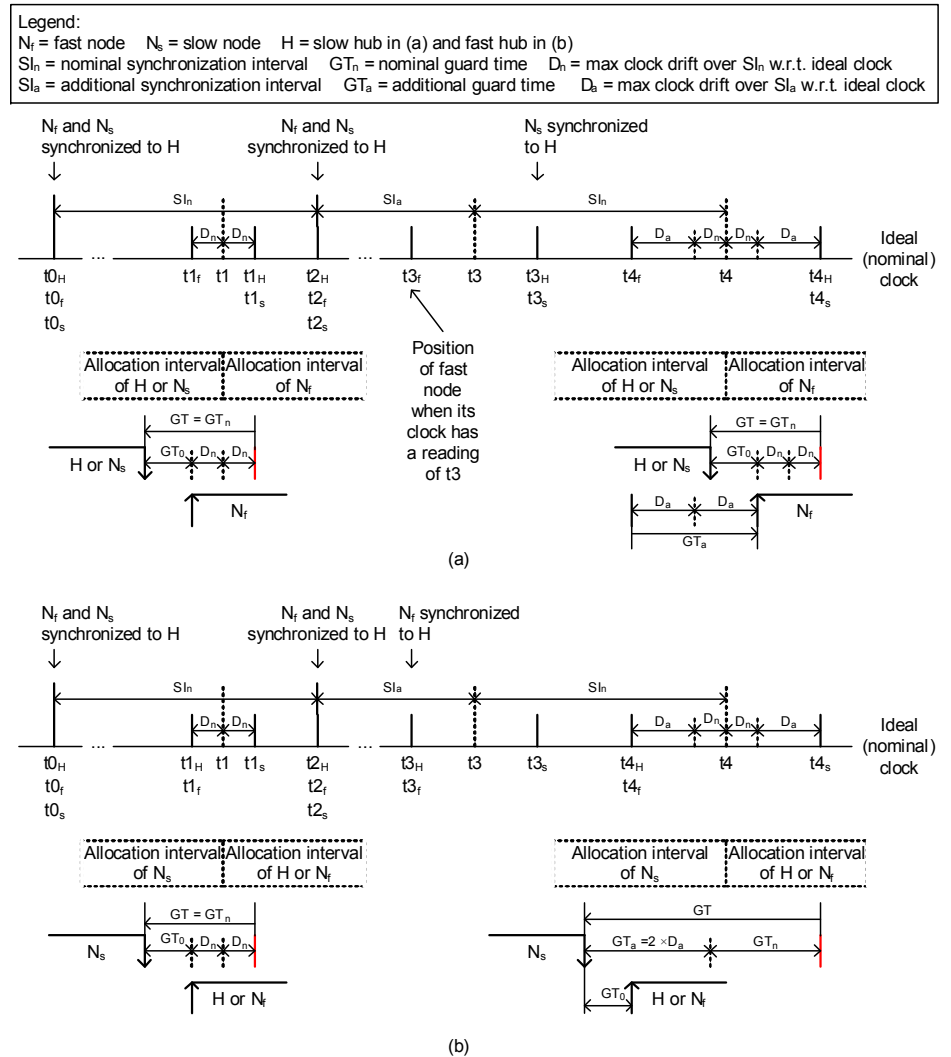

MAC Frame Format

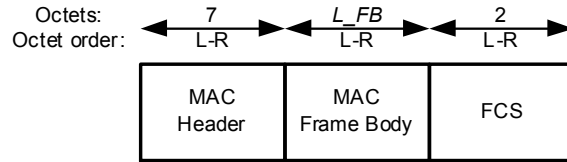

MAC frame format

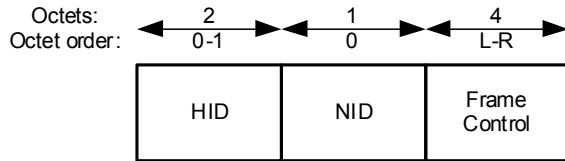

MAC header format

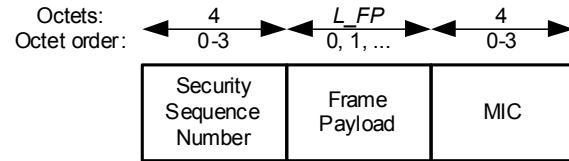

MAC frame body format

NID selection

NID value in hex	NID notation	NID usage
x00	Unconnected_Broadcast_NID	For broadcast to unconnected nodes
x01-0F	Unconnected_NID	For unicast to unconnected nodes
x10-EF	Connected_NID	For unicast to/from connected nodes
xF0-FE	Multicast_NID	For multicast to connected nodes
xFF	Broadcast_NID	For broadcast to all nodes

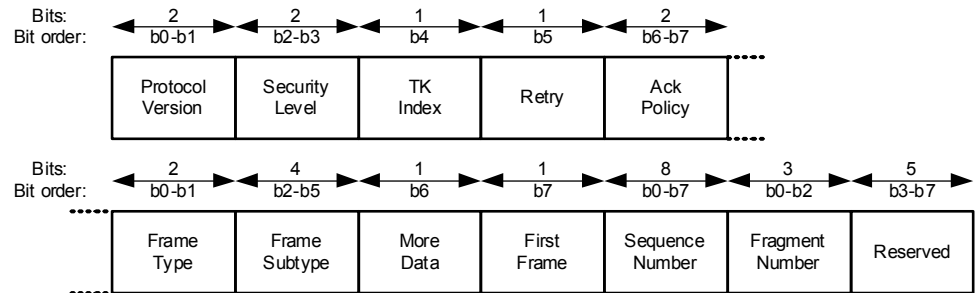

Frame control format

Frame Types and Subtypes

Frame Type value b0 b1	Frame Type name	Frame Subtype value b2 b3 b4 b5	Frame Subtype name
00	Management	0000	Beacon
00	Management	1000	Reserved
00	Management	0100	Association
00	Management	1100	Disassociation
00	Management	0010	PTK
00	Management	1010	GTK
00	Management	0110-1110	Reserved
00	Management	0001	Connection Request
00	Management	1001	Connection Assignment
00	Management	0101	Disconnection
00	Management	1101-1111	Reserved
10	Control	0000	I-Ack
10	Control	1000	B-Ack
10	Control	0100	I-Ack+Poll
10	Control	1100	B-Ack+Poll
10	Control	0010	Poll
10	Control	1010-1111	Reserved
01	Data	0000-1111	User defined data subtype
11	Reserved	0000-1111	Reserved