

¹IEEE P802.15
Wireless Personal Area Networks

| | | |
|----------------|---|-------------------|
| Project | IEEE P802.15 Working Group for Wireless Personal Area Networks (WPANs) | |
| Title | ETRI + Samsung Physical layer proposal | |
| Date Submitted | May 2, 2009 | |
| Source | Kiran Bynam(1), Noh-Gyoung Kang(1), Chihong Cho(1), Seung-Hoon Park(1), Sridhar Rajagopal(1), Eun Tae Won(1), Giriraj Goyal(1), Arun Naniyat(1), Mi-Kyung Oh(2), Hyung Soo Lee(2), Chul-Hyo Lee(2), Jae-Young Kim(2), Jae-Ho Hwang(3), Jae-Myung Kim(3) | etwon@samsung.com |
| | [(1) Samsung Electronics, (2) ETRI, (3) Inha Univ.] | |
| Re: | IEEE 802.15 TG6 Body Area Networks (BAN). | |
| Abstract | ETRI + Samsung PHY proposal Presentation to TG6 group | |
| Purpose | This document is intended to explain the overview and details of the ETRI + Samsung PHY proposal | |
| Notice | This document has been prepared to assist the IEEE P802.15. It is offered as a basis for discussion and is not binding on the contributing individual(s) or organization(s). The material in this document is subject to change in form and content after further study. The contributor(s) reserve(s) the right to add, amend or withdraw material contained herein. | |
| Release | The contributor acknowledges and accepts that this contribution becomes the property of IEEE and may be made publicly available by P802.15. | |

Draft for 802.15.6 PHY

(Samsung Electronics + ETRI)

Contents

| | | |
|-----|--|----|
| 1. | Introduction..... | 4 |
| 2. | Technical Requirements for IEEE 802.15.6 | 4 |
| 3. | Overview of the proposal..... | 4 |
| 4. | General block Diagram | 5 |
| 5. | G-PPM Modulation..... | 5 |
| 6. | Pulse Shapes..... | 13 |
| 7. | Data Rates | 15 |
| 8. | Co-existence..... | 16 |
| 9. | Frame Format..... | 22 |
| 10. | PER Results and Link Budget | 22 |
| 11. | Power Consumption | 26 |
| 12. | Self Evaluation | 26 |
| 13. | Summary | 26 |
| 14. | References | 27 |

1. Introduction

The scope of this document is the proposal for physical Layer for on-body communications as response to the Call for Proposals issued by the IEEE 802.15.6. This document will address the modulation schemes, preambles required for the 802.15.6 physical layer. It also addresses how the proposal meets different technical requirements documented by TG6. Finally, it summarizes the proposal capabilities in meeting the technical requirements and the different metrics set forward by TG6 as the comparison criterion.

2. Technical Requirements for IEEE 802.15.6

The requirements that are set forward by the IEEE 802.15.6 are

- Scalability of data rates from 10 kbps to 10 Mbps
- Shall support a range of 3 m at lowest mandatory rate
- 10 piconet co-existence at the lowest mandatory data rate
- Low Power & complexity
- Regulatory Compliance

The comparison criterion relevant to PHY layer is

- Power consumption estimates
- Range for all the data rates
- Co-existence with other networks like ECMA 368

The performance of the proposal with respect to the requirements and comparison criteria is summarized at the end

3. Overview of the proposal

This proposal is designed to satisfy the technical requirements of the BAN and also to optimize the Power consumption. The

Features of this proposal are as follows

- PPM modulation Scheme
- Non-coherent receiver
- Different Pulse shapes including Chaotic, Gaussian monocycle, Raised Cosine
- Ultra Wide band spectrum from 7.25 GHz to 8.5 GHz with two frequency bands
- Low Power due to duty cycling

4. General block Diagram

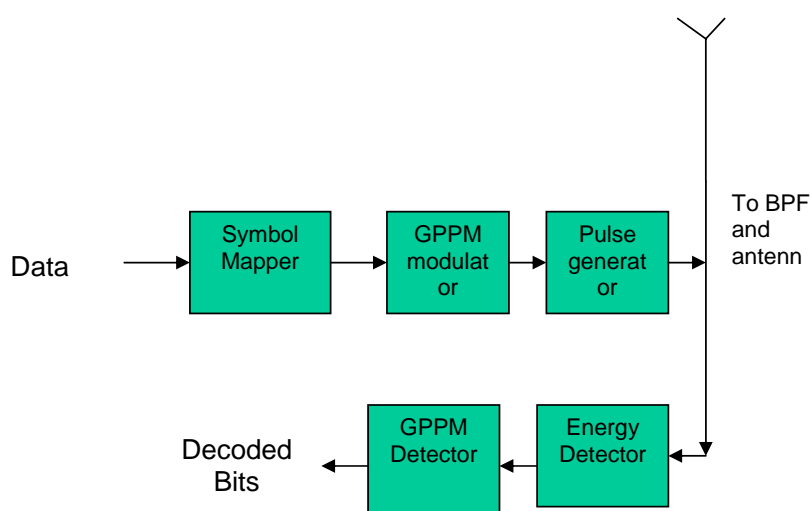

Figure.4. 1 : Block Diagram

5. G-PPM Modulation

G-PPM is a block coded pulse position modulation scheme. The block of k bits are used to select one of the 2^k length chip sequence optimally selected sequences out of the (2^{2^k}) possible sequences. This chip sequence is modulated with the pulse shapes. At the receiver, the energy levels of each chip is decoded as '1's and '0's and the hamming distance between all the possible codes are found out. The symbols with k bits with the maximum energy are detected as '1's and others as zero. The symbol with the minimum hamming distance is selected as the transmitted codeword.

In this proposal, we used as 6th order ($k = 6$) G-PPM modulation for simulation. The sequences used for the PPM modulation are given below. This modulation is applied to all the data rates specified in the data rates section.

Symbol structure: Each symbol period (T_{sym}) is divided into 2 parts of duration $T_{ppmChip} = T_{sym}/2$. One for bit '0' and another for bit '1'. Each $T_{ppmChip}$ period is divided into 2 parts. First part is for the burst (T_{burst}). Second part is Guard interval

(TGaurd). The 8 Gaussian monocycles of 16 nsec width or the chaotic pulse of 16nsec width is placed in the Tburst position.

Exception of the modulation scheme for 10.8 Mbps: The data is divided into 8 symbols and each symbol is used to select a 12-bit chip sequence out of 256 pre-defined sequences

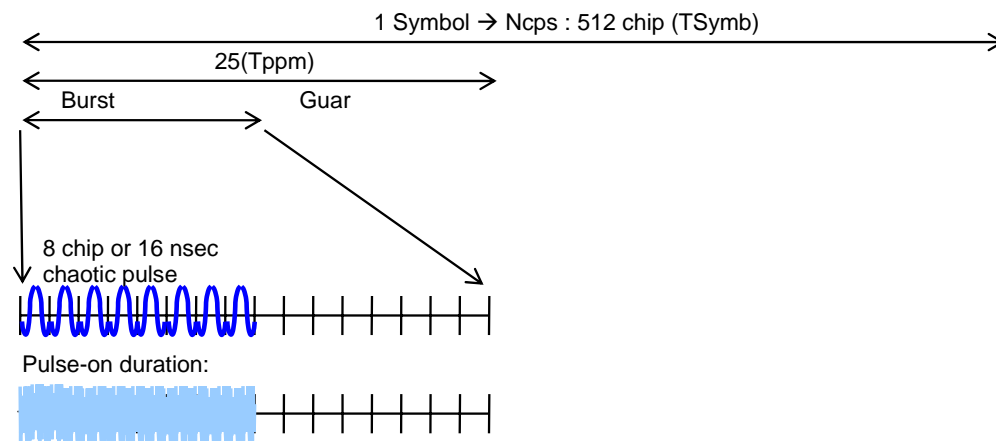

Figure 5.1: symbol structure for 1 Mbps data rate

Chip sequences for 10k, 100k, 1Mbps data rates.

```
0 0 0 0 0 0 1 1 1 1 1 1
0 0 0 0 1 1 0 1 1 0 1 1
0 0 0 1 1 1 0 0 0 1 1 1
0 0 0 0 1 1 1 0 1 1 0 1
0 0 0 1 1 1 1 1 1 0 0 0
0 0 0 0 1 1 1 1 0 1 1 0
0 1 1 0 0 1 1 1 0 1 0 0
0 0 1 0 0 1 0 1 0 1 1 1
0 1 1 0 0 1 0 0 1 0 1 1
0 0 0 1 0 1 1 0 1 0 1 1
0 0 0 1 0 1 0 1 1 1 0 1
0 0 0 1 0 1 0 1 1 1 0 1
1 1 0 1 0 0 0 1 1 0 0 1
0 0 1 1 0 0 0 1 1 0 1 1
1 0 1 0 1 0 0 1 0 0 1 1
0 0 0 1 1 0 1 1 0 0 1 1
0 0 0 1 1 0 0 1 1 1 1 0
0 1 1 1 1 0 0 0 1 1 0 0
0 0 1 0 1 0 0 0 1 1 1 1
0 0 1 0 0 1 1 1 0 0 1
0 0 1 0 0 1 1 1 1 0 0 1
0 0 1 0 1 0 1 1 1 0 1 0
1 0 1 1 0 0 1 0 0 1 0 1
0 0 1 1 0 0 1 1 0 1 1 0
0 0 1 0 1 0 1 1 1 1 0 0
0 0 1 1 1 1 0 0 1 0 1 0
0 0 1 0 1 1 1 1 0 0 1 1
0 0 1 1 1 1 0 1 0 1 0 0 1
0 0 1 1 1 1 1 0 1 0 0 0 1
0 0 1 1 1 1 1 1 0 0 1 0 0
0 1 0 1 1 1 1 1 0 1 0 0 0
0 1 0 0 0 1 1 1 0 1 1 0 0
0 1 0 0 0 0 1 0 1 1 1 1 0
0 1 0 0 0 1 1 1 1 1 1 1
0 1 0 0 0 0 1 1 1 1 0 0
0 1 0 0 0 1 0 0 1 1 1 1 0
0 1 0 0 1 0 0 1 0 1 1 0 0
0 1 0 0 1 1 0 0 1 0 0 0 0
0 1 0 0 1 0 0 1 1 0 1 0 0
0 1 0 0 1 1 0 1 1 0 1 0 0
0 1 0 0 1 0 1 1 0 1 1 0 0
1 0 0 0 0 1 1 1 0 0 1 1
1 0 0 0 0 1 0 0 0 1 1 1 1
1 0 0 0 0 1 1 1 1 1 0 0
1 0 0 0 1 0 0 0 1 0 1 1 1
1 0 0 0 1 0 0 1 0 1 1 1 0
1 0 0 0 1 1 1 1 0 1 0 1 0
1 0 0 1 0 1 1 0 1 1 0 1 0
1 0 0 1 1 0 0 0 0 1 0 1 1
```

Code set for 10 Mbps data rate:

```

0 0 0 0 0 0 1 1 1 1 1 1
0 0 0 0 0 1 0 1 1 1 1 1
0 0 0 0 1 1 0 1 1 0 1 1
0 0 0 0 0 1 1 1 1 0 1 1
0 0 0 1 0 1 1 0 1 0 1 1
0 0 0 0 0 1 1 0 1 1 1 1
0 0 0 0 1 1 1 0 1 1 0 1
0 0 0 0 0 1 1 1 1 1 0 1
0 0 0 1 0 1 0 1 1 1 0 1
0 0 0 0 1 1 0 1 1 1 0 1
0 0 1 0 1 1 0 1 1 1 0 0
0 0 0 0 1 1 0 1 1 1 1 0
0 0 0 0 1 1 1 1 0 1 1 0
0 0 0 0 0 1 1 1 0 1 1 1
0 0 1 0 0 1 0 1 0 1 1 1
0 0 0 0 1 1 0 1 0 1 1 1
0 0 0 1 1 1 1 0 0 0 1 1 1
0 0 0 0 1 1 0 0 0 1 1 1 1
0 0 1 0 1 0 0 0 1 1 1 1 1
0 0 0 0 1 0 0 1 1 1 1 1 1
0 0 0 0 1 1 1 0 0 0 1 1 1
0 0 0 1 1 1 1 0 0 0 1 1 1
0 0 0 0 1 1 0 0 1 1 1 1 1
0 0 1 0 1 0 1 1 0 0 1 1 1
0 0 0 0 1 0 1 1 1 1 0 1 1
0 0 0 1 1 0 0 1 1 1 0 0 1
0 0 0 0 1 1 1 1 1 1 0 0 0
0 0 0 0 1 1 1 1 1 1 0 0 1
0 0 1 0 0 1 1 1 1 1 0 0 1
0 0 0 1 0 1 1 1 1 1 0 0 1
0 0 0 1 0 0 1 1 1 1 0 1 1
0 0 1 1 0 0 0 1 1 1 0 1 1
0 1 0 1 0 0 0 0 1 1 1 1 1
0 0 0 1 0 0 1 0 1 1 1 1 1
1 0 0 1 0 0 1 0 1 1 1 0
0 0 0 1 0 0 1 1 1 1 1 0
0 0 1 1 0 0 1 1 0 1 1 0
0 0 0 1 0 0 1 1 0 1 1 1
0 1 0 1 0 0 1 1 0 1 0 1

```

0 0 0 1 0 0 1 1 1 1 0 1
0 0 0 1 0 1 1 0 1 1 0 1
0 1 0 1 0 1 1 0 1 1 0 0
0 0 0 1 0 1 1 0 1 1 1 0
0 0 1 0 0 1 1 0 1 1 1 0
0 0 0 0 0 1 1 1 1 1 1 0
0 1 0 0 0 1 0 1 1 1 1 0
0 0 0 1 0 1 0 1 1 1 1 0
1 0 0 1 0 1 0 1 1 0 1 0
0 0 0 1 0 1 0 1 1 0 1 1
0 1 0 1 0 1 0 1 0 0 1 1
0 0 0 1 0 1 0 1 0 1 1 1
1 0 0 1 0 0 0 1 0 1 1 1
0 0 0 1 1 0 0 1 0 1 1 1
0 1 0 0 1 0 0 1 0 1 1 1
0 0 1 0 1 0 0 1 0 1 1 1
1 0 1 0 1 0 0 1 0 0 1 1
0 0 1 0 1 0 0 1 0 1 1 1
0 0 0 1 1 0 0 1 0 1 1 1
1 0 0 1 1 0 0 0 1 0 1 1
0 0 0 1 1 0 0 0 1 1 1 1
0 0 0 0 1 0 1 0 1 1 1 1
0 1 0 0 1 0 1 0 1 0 1 1
0 0 0 0 1 1 1 0 1 0 1 1
0 0 1 0 1 1 1 0 0 0 1 1
0 0 0 0 1 1 1 0 0 1 1 1
0 1 0 0 0 1 1 0 0 1 1 1
0 0 0 1 0 1 1 0 0 1 1 1
0 0 0 1 0 1 0 0 1 1 1 1
1 0 0 0 0 1 0 0 1 1 1 1
0 0 1 0 0 1 0 0 1 1 1 1
0 1 1 0 0 1 0 0 1 0 1 1
0 0 1 0 0 1 0 1 1 0 1 1
0 0 1 0 0 0 0 1 1 1 1 1
0 1 1 0 0 0 0 1 1 1 0 1
0 0 1 0 0 0 1 1 1 1 0 1
0 0 1 0 0 0 1 0 1 1 1 1
1 0 1 0 0 0 1 0 1 0 1 1
0 0 1 0 0 0 1 1 1 0 1 1
0 1 1 0 0 0 1 1 0 0 1 1
0 0 1 0 0 0 1 1 0 1 1 1
0 0 1 0 0 0 1 1 1 1 1 0
1 0 1 0 0 0 0 1 1 1 1 0
0 0 1 0 0 1 0 1 1 1 1 0
0 0 1 0 0 1 0 1 1 1 0 1
0 0 1 0 0 1 1 0 1 1 0 1
0 0 1 0 0 1 1 0 1 1 0 1

0 0 1 0 0 1 1 0 0 1 1 1
0 0 1 0 0 1 1 0 1 0 1 1
0 0 1 0 0 1 1 1 0 0 1 1
1 0 0 0 0 1 1 1 0 0 1 1
0 0 0 0 1 1 1 1 0 0 1 1
0 1 0 0 1 1 1 1 0 0 0 1
0 0 0 0 1 1 1 1 0 1 0 1
0 0 0 1 0 1 1 1 0 1 0 1
0 0 0 1 0 1 1 1 0 0 1 1
0 0 0 1 0 1 1 1 0 1 1 0
0 0 0 1 0 1 1 1 1 0 1 0
0 1 0 1 0 0 1 1 1 0 1 0
0 0 0 1 1 0 1 1 1 0 1 0
0 0 0 0 1 1 1 1 1 0 1 0
1 0 0 0 1 1 1 0 1 0 1 0
0 0 0 0 1 1 1 0 1 1 1 0
0 0 0 1 1 0 1 0 1 1 1 0
0 0 0 1 1 0 1 0 0 1 1 1
0 0 0 1 1 0 1 0 1 0 1 1
0 0 1 1 1 0 1 0 1 0 0 1
0 0 0 1 1 0 1 0 1 1 0 1
0 0 0 1 1 0 0 1 1 1 0 1
1 0 0 0 1 0 0 1 1 1 0 1
0 0 1 0 1 0 0 1 1 1 0 1
0 0 1 0 1 0 0 1 1 1 1 0
0 0 1 0 1 0 1 0 1 1 1 0
1 0 1 0 1 0 1 0 1 1 0 0
0 0 1 0 1 0 1 0 1 1 0 1
0 0 1 0 1 0 1 0 0 1 1 1
0 0 1 0 1 0 1 0 1 0 1 1
0 0 1 0 1 0 1 1 0 0 1 1
0 0 1 0 1 0 1 1 0 1 1 0
0 0 0 1 1 0 1 1 0 1 1 0
1 0 0 1 1 0 1 1 0 1 0 0
0 0 0 1 1 0 1 1 0 1 0 1
0 0 0 1 1 0 1 1 1 0 0 1
0 0 0 1 0 1 1 1 1 1 0 0
0 0 0 1 0 1 1 1 1 1 0 0
1 0 0 0 0 1 1 1 1 1 0 0
0 0 1 0 0 1 1 1 1 1 0 0
0 1 1 0 0 1 1 1 0 1 0 0
0 0 1 0 0 1 1 1 0 1 0 1
0 0 1 0 0 1 1 1 0 1 1 0
0 0 1 0 0 1 1 1 1 0 1 0
0 0 1 0 1 1 0 1 1 0 1 0
0 0 1 1 1 1 0 0 1 0 1 0

0 0 0 1 1 1 0 0 1 0 1 1
0 1 0 1 1 1 0 0 1 0 0 1
0 0 0 1 1 1 0 0 1 1 0 1
1 0 0 1 1 1 0 0 1 1 0 0
0 0 0 1 1 1 0 0 1 1 1 0
0 0 0 1 1 1 0 1 0 1 1 0
0 1 0 1 1 1 0 1 0 1 0 0
0 0 0 1 1 1 0 1 0 1 0 1
0 0 1 1 1 1 0 1 0 0 0 1
0 0 0 1 1 1 0 1 0 0 1 1
0 0 0 1 1 1 0 1 1 0 0 1
0 0 0 1 1 1 0 1 1 0 1 0
0 0 0 1 1 1 0 1 1 1 0 0
0 0 0 1 1 1 1 0 1 1 0 0
0 0 1 1 1 1 1 0 0 1 0 0
0 0 0 1 1 1 1 0 0 1 0 1
1 0 0 1 1 1 1 0 0 0 0 1
0 0 0 1 1 1 1 0 0 0 1 1
0 1 0 1 1 1 1 0 0 0 1 0
0 0 0 1 1 1 1 0 0 1 1 0
0 0 0 1 1 1 1 0 1 0 1 0
0 0 0 1 1 1 1 0 1 0 0 1
0 0 0 1 1 1 1 1 0 0 0 1
0 0 0 1 1 1 1 1 0 0 1 0
0 0 0 1 1 1 1 1 0 1 0 0
0 0 1 0 1 1 1 1 0 1 0 0
1 0 1 0 1 1 1 1 0 0 0 0
0 0 1 0 1 1 1 1 0 0 0 1
0 0 1 0 1 0 1 1 1 0 0 1
0 0 1 0 1 0 1 1 1 1 0 0
0 0 1 0 1 1 1 0 1 1 0 0
0 1 1 0 1 1 1 0 1 0 0 0
0 0 1 0 1 1 1 0 1 0 0 1
1 0 1 0 1 1 0 0 1 0 0 1
0 0 1 0 1 1 0 0 0 1 1 1
0 0 1 0 1 1 0 0 0 1 0 1
0 0 1 0 1 1 0 0 1 1 0 1
0 0 1 0 1 1 0 0 1 1 1 0
1 0 1 0 1 1 0 0 0 1 1 0
0 0 1 0 1 1 0 1 0 1 1 0
0 1 1 0 1 1 0 1 0 0 1 0
0 0 1 0 1 1 0 1 0 0 1 1
0 0 1 0 1 1 0 1 0 1 0 1
0 0 1 0 1 1 0 1 1 0 0 1
0 0 1 0 1 1 1 1 1 0 0 0
0 0 1 0 1 1 1 1 1 0 0 0

0 0 1 0 1 1 1 0 1 0 1 0
0 0 1 0 1 1 1 0 0 1 1 0
0 0 1 0 1 1 1 0 0 1 0 1
0 0 1 1 0 1 1 0 0 1 0 1
1 0 1 1 0 0 1 0 0 1 0 1
0 0 1 1 0 0 1 0 0 1 1 1
0 0 1 1 0 0 0 0 1 1 1 1
0 0 1 1 0 0 0 1 0 1 1 1
0 0 1 1 0 0 0 1 1 1 0 1
0 0 1 1 0 0 0 1 1 1 1 0
0 0 1 1 0 0 1 0 1 1 1 0
0 0 1 1 0 0 1 0 1 0 1 1
0 0 1 1 0 0 1 0 1 1 0 1
0 0 1 1 0 0 1 1 0 1 0 1
0 0 1 1 0 0 1 1 1 0 0 1
1 0 1 1 0 0 1 1 1 0 0 0
0 0 1 1 0 0 1 1 1 0 1 0
0 0 1 1 0 0 1 1 1 1 0 0
0 0 1 1 0 1 0 1 1 1 0 0
0 1 1 1 0 1 0 1 1 0 0 0
0 0 1 1 0 1 0 1 1 0 0 1
0 0 1 1 0 1 0 0 1 0 1 1
1 0 1 1 0 1 0 0 0 0 1 1
0 0 1 1 0 1 0 0 0 1 1 1
0 1 1 1 0 1 0 0 0 1 1 0
0 0 1 1 0 1 0 0 1 1 1 0
0 0 1 1 0 1 0 0 1 1 0 1
0 0 1 1 0 1 0 1 0 1 0 1
1 0 1 1 0 1 0 1 0 1 0 0
0 0 1 1 0 1 0 1 0 1 1 0
0 0 1 1 0 1 0 1 0 0 1 1
0 0 1 1 0 1 0 1 1 0 1 0
0 0 1 1 0 1 1 0 0 0 1 1
0 1 1 1 0 1 1 0 0 0 0 1
0 0 1 1 0 1 1 0 1 0 0 1
0 0 1 1 0 1 1 0 1 1 0 0
0 0 1 1 0 1 1 0 0 1 1 0
0 0 1 0 1 1 1 1 0 0 1 0
0 1 1 1 1 0 1 1 0 0 0 0
0 1 1 1 1 0 0 0 1 1 0 0
0 0 1 1 1 0 0 0 1 1 0 1
0 0 1 1 1 0 0 0 0 1 1 1
0 1 1 1 1 0 0 0 0 0 1 1

```

0 0 1 1 1 0 0 0 1 0 1 1
0 0 1 1 1 0 0 0 1 1 1 0
0 0 1 1 1 0 0 1 0 1 1 0
0 0 1 1 1 0 0 1 0 0 1 1
0 0 1 1 1 0 0 1 0 1 0 1
0 0 1 1 1 0 0 1 1 0 0 1
0 0 1 1 1 0 0 1 1 0 1 0
1 0 1 1 1 0 1 0 0 0 1 0
1 1 0 0 1 0 1 0 0 1 1 0
1 1 0 0 0 0 1 0 1 1 0 1
1 1 0 1 0 0 0 1 1 0 0 1
1 1 0 0 0 1 0 1 0 1 0 1
1 1 0 0 1 1 0 0 0 0 1 1
1 1 0 0 1 0 0 1 1 0 1 0
1 1 0 1 1 0 1 0 1 0 0 0
1 1 0 1 0 0 1 0 0 0 1 1
1 1 0 1 0 1 1 1 0 0 0 0
1 1 1 0 0 1 1 0 0 0 1 0
1 1 1 0 0 0 0 0 0 1 1 1
1 1 0 1 1 0 0 0 0 1 0 1
1 1 1 0 1 0 0 1 0 1 0 0
1 1 1 0 0 1 0 0 1 1 0 0
1 1 1 1 0 0 0 0 1 0 1 0
1 1 1 1 1 1 0 0 0 0 0 0
1 1 1 0 1 0 1 0 0 0 0 1
0 0 1 1 0 1 1 1 0 0 0 1
0 0 1 1 0 1 1 1 0 1 0 0
0 0 1 1 0 1 1 1 1 0 0 0

```

6. Pulse Shapes

Pulse shape can be anything that satisfies the UWB regulations. Some of the pulse shapes that we find suitable for the Gaussian Monocycle, Chaos signal and the raised cosine pulses. This section currently talks about the chaos pulses and their suitability to the UWB. Chaos pulses are near constant envelope signals that are produced by mixing 4 different triangular/saw-tooth waveforms. The sum of these triangular or saw-tooth waveforms will be the input to the voltage controlled oscillator. This is similar to frequency modulating a carrier signal with the summation of the triangular signals. The center frequency of the oscillator is directly proportional to the DC offset of the VCO.

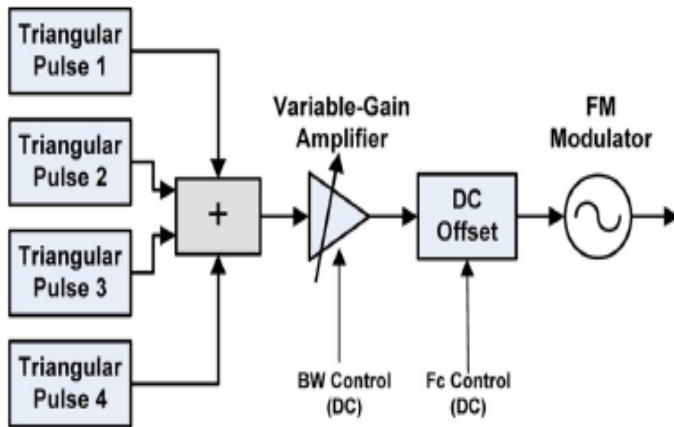

Figure 6.1. Chaos Generator using triangular waveform

The width of the triangular pulses and the peak to peak amplitudes are chosen to achieve the 500 MHz bandwidth. The period of the 4 triangular pulses are chose as 2, 3, 5 and 7 nsec respectively. This summation will result in a spectrum shape with 10 dB bandwidth of 500 MHz. The spectrum of the chaos signal thus generated is given below.

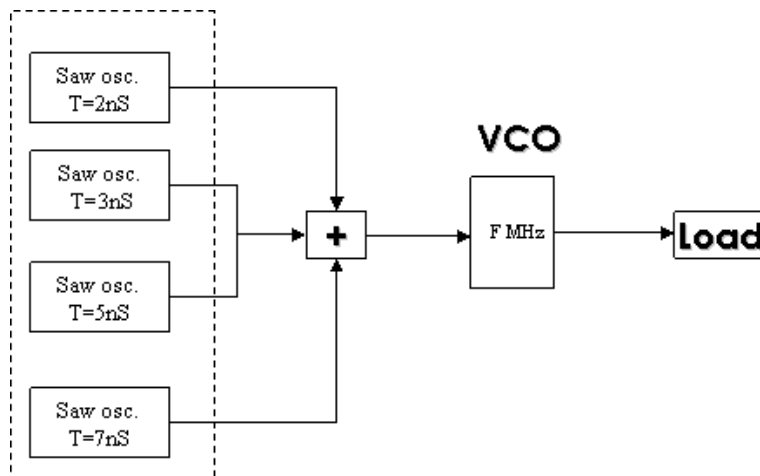

Figure 6.2: Chaos generator using saw tooth pulses.

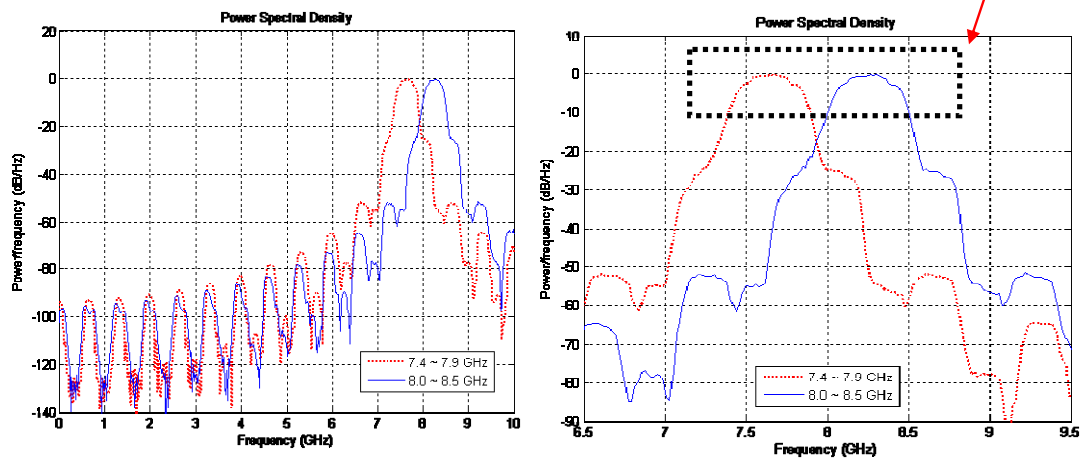

Figure 6.3.: Spectrum of the Chaos Pulses

7. Data Rates

Data rates proposed in this proposal are listed below. Please note that the chips proposed in this table are Gaussian monocycle pulses of 2.0324 nsec. This signal can be replaced with the chaos signal of same duration. The length of the chaos pulse in the burst is equal to the number of the pulses per burst * 2.0324 nsec.

| Mod-Type | Chip rate (Fc) | # of chips per symbol (Ncps) | # of burst positions per symbol (Nburst) | # of chips per burst (Ncpb) | # of chips for pulse-on duration (Ncpo) | Symbol Rate (MHz) | Bit Rate (Mbps) |
|----------|----------------|------------------------------|--|-----------------------------|---|-------------------|-----------------|
| 00 | 500MHz | 32768 | 32 | 1024 | 8 | 0.015 | 0.015 |
| 01 | 500MHz | 4096 | 32 | 128 | 8 | 0.120 | 0.120 |
| 10 | 500MHz | 512 | 32 | 16 | 8 | 0.976 | 0.976 |
| 11 | 500MHz | 64 | 32 | 2 | 2 | 7.8 | 10.4 |

8. Co-existence

The co-existence of the 10 BAN networks is one of the requirements for IEEE 802.15.6. The regulations on UWB spectrum are different in different regions of the world. Some countries like China, Europe etc will mandate the use of Detect and Avoid mechanisms to save the primary services from getting affected. But, such detect and avoid mechanisms are complex and could be very power consuming and, hence not suitable for the BAN. The spectrum that is allowed in different parts of the region without any such stringent regulations is 7.25 to 8.5 GHz.

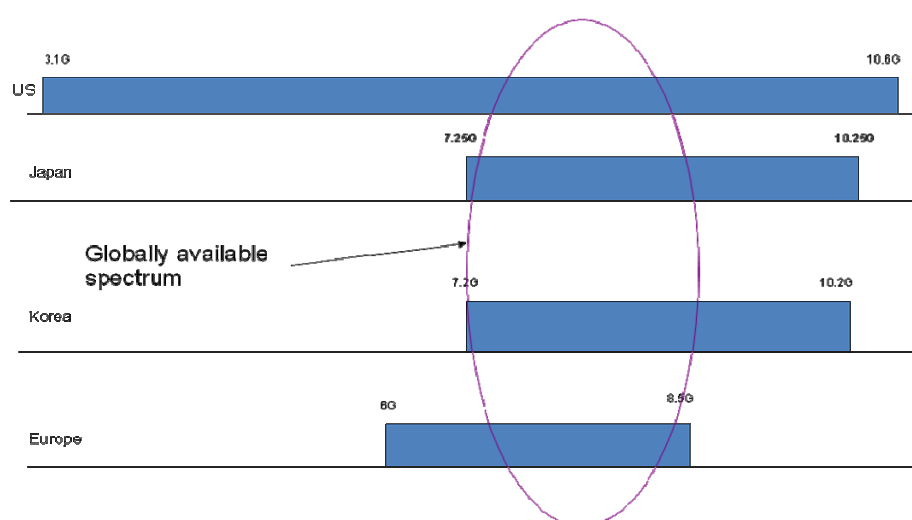

Figure 8.1 : DAA-free world-wide UWB spectrum allocation in different bands

Since, UWB also has a requirement of 500 MHz minimum bandwidth, effectively, 2 bands are possible in this region. We propose to use the duty cycling of the modulation scheme to assist in the co-existence of the multiple piconets. The lowest duty cycling factor used in the proposed UWB scheme is $1/32$. With this duty cycling and the TH codes in tandem will assist the co-existence of the 5 piconets in a single frequency band of 500 MHz. Since, the piconets are asynchronously overlapped in time in the same frequency band as shown in figure below, there is a need for synchronization in the presence of interference.

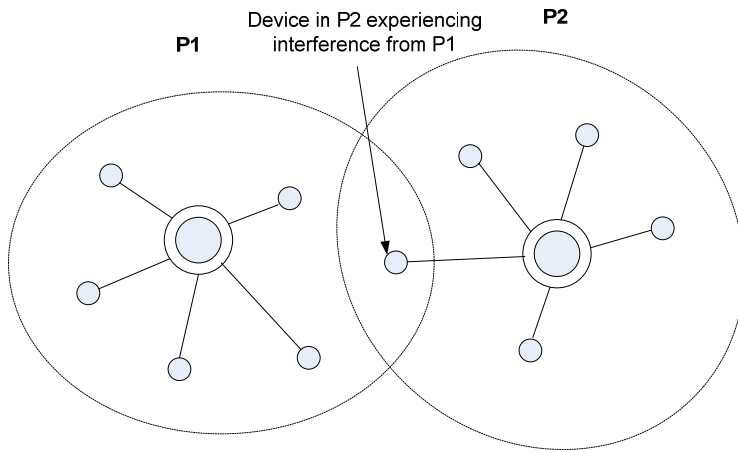

Figure 8.2: Piconet interference between piconets P1 and P2

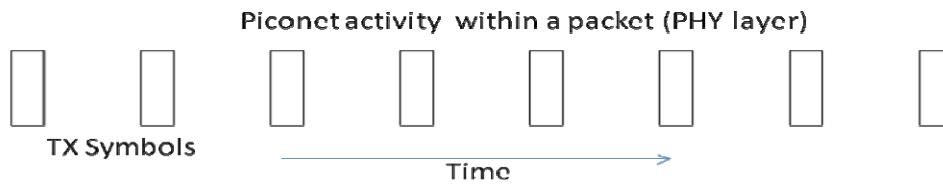

Figure8.3 activity within a packet in PHY mode with low duty cycle

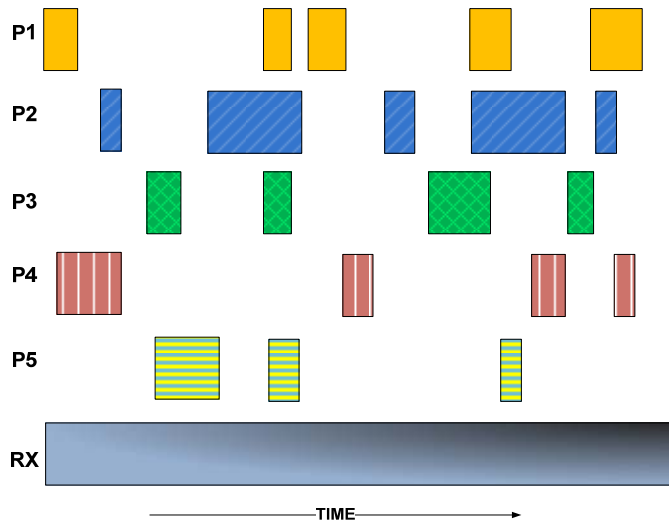

Figure 8.4: Piconet co-existence

It is also possible for the MAC to provide better support when piconets can communicate with each other. For example, in such cases, piconets could share time resources based on requests and also could synchronize to an offset in the low duty cycle case. An example is as shown below. We consider such cases in more detail in the Samsung MAC proposal.

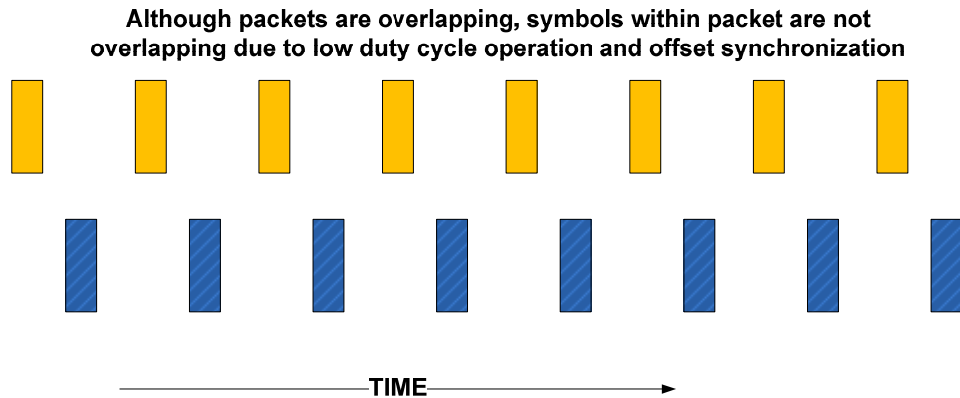

Figure 8.5: Offset piconet synchronization for co-existence with overlapping packets

Sequences:

The preamble sequences for these piconets operating together should have good cross correlation properties with each other. Another requirement for these preambles is to have good autocorrelation gain at zero lag to detect the data frame synchronization accurately. Eight preamble sequences of length 63 are designed to suit these requirements are shown below. The constraints used in the sequence design are as follows:

- Need to have at least 5 piconet codes
- Codes need to binary to support non-coherent reception for power savings in BAN
- Codes should not assume synchronization (for example, codes such as Walsh codes cannot be used)
- Code length should be as short as possible, not exceeding 64 bits or so for power savings
- Must have excellent auto and cross correlation properties within the signal set

```

1 1 1 1 1 1 0 1 0 1 0 1 1 0 0 1 1 1 0 1 1 1 0 1 1 0 1 1 0 1 1 0 1 1 0 1 0 0 1 0 0 1 0 0 0 0 1 1 0 0 0 0 1 0 0 0 0 0 1 0 0 0 0 0
0 0 0 1 1 0 0 0 1 0 0 1 0 0 1 0 0 0 1 0 0 1 0 0 0 1 1 0 0 0 1 1 0 0 0 1 1 1 0 0 0 1 1 0 1 0 0 1 1 0 1 0 1 1 0 0 0 1 0 0 1 0
1 0 0 1 1 1 1 0 1 1 1 1 0 0 0 1 0 0 1 1 1 0 0 0 0 1 1 0 1 1 0 1 1 1 0 1 1 1 0 0 0 1 1 0 0 0 1 0 0 0 1 0 0 1 0 0 1 0 0 1
0 1 0 0 0 1 0 0 0 0 1 0 1 0 1 1 1 0 1 1 1 1 0 0 1 0 0 1 0 0 0 1 0 0 1 0 1 1 1 0 0 1 0 1 0 1 0 0 1 0 0 1 1 1 1 1 0 0 1
1 0 1 0 0 0 0 1 1 1 1 0 0 0 0 0 1 1 0 0 0 0 0 0 0 1 1 0 0 0 1 1 1 0 0 0 1 1 1 0 0 0 1 1 0 1 1 0 0 0 0 1 1 1 1 0
1 0 1 0 0 1 1 0 0 0 1 0 0 0 0 0 0 1 0 0 0 1 0 0 0 1 0 0 1 0 0 0 0 0 0 0 0 0 0 0 0 0 0 0 0 0 0 0 0 0 0 0 0 0 0 0 1 1 1 0 1 1 1
0 1 1 0 1 0 1 0 0 1 1 1 0 1 1 1 1 1 0 0 0 1 1 1 0 1 1 1 0 0 0 0 0 0 0 0 0 0 0 0 0 0 0 0 0 0 1 1 0 1 0 0 1 1 1 0 1 0 1 1
0 0 1 1 0 1 1 0 1 1 0 0 1 1 1 0 1 0 0 1 0 1 0 1 1 1 1 0 0 1 0 0 1 0 0 1 1 1 1 1 1 1 1 1 1 0 1 1 0 0 0 1 1 0 0 0 1 0 1 1
    
```

Figure 8.6: 8 preamble sequences for piconet selection

With the help of these 8 sequences, co-existence of 16 piconets is possible within the 1 GHz frequency band. The auto correlation and cross correlation properties of these sequences are shown below.

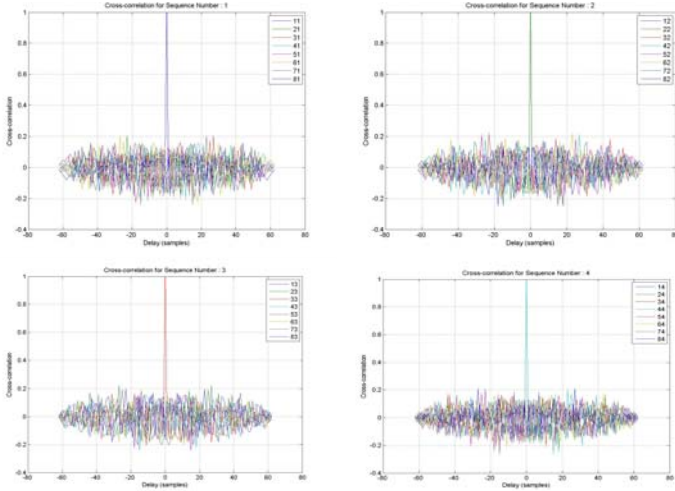

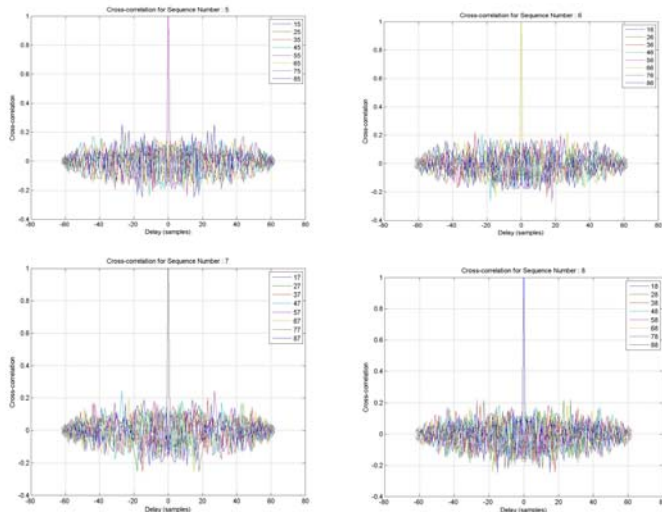

Figure 8.7 : Auto- and cross- correlation properties

Rationale for chip rate, Duty cycling:

The chip rate and duty cycle for this preamble depends on the lowest chip rate of the system. The current system works with the lowest chip rate of 10 kcps with the duty cycle of $1/32$. For higher data rates, the width of the chip is very small. Hence, it is required to detect the frame synchronization with a resolution of less than $1/2$ times the chip width. Hence the width of the chip in the preamble should be less than or equal to the width of the chip for highest data rate. The duty cycling of the preamble should be $1/32$, equal to that of the lowest data rate. The preamble performance will not be a limiting factor for the performance of the lowest data rate.

Results:

Uses of the preamble are two fold. First, detect the data frame synchronization with the desired preamble. Second use is the identification of the preambles in the frequency band and selection of appropriate preamble with lowest energy level at the receiver at the network setup time. The auto-correlation and cross-correlation of these preambles for these two scenarios are plotted.

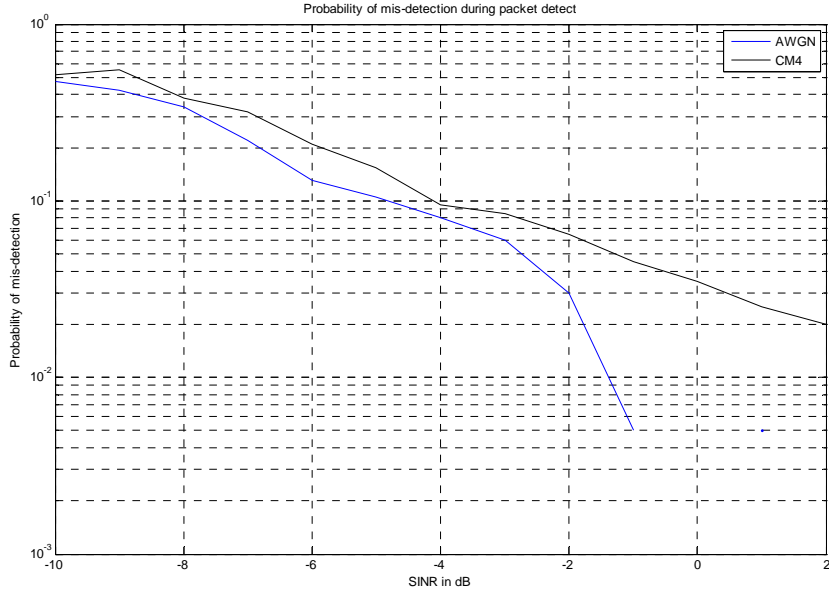

Figure 8.8. Mis-detection of the preamble for different SINR conditions

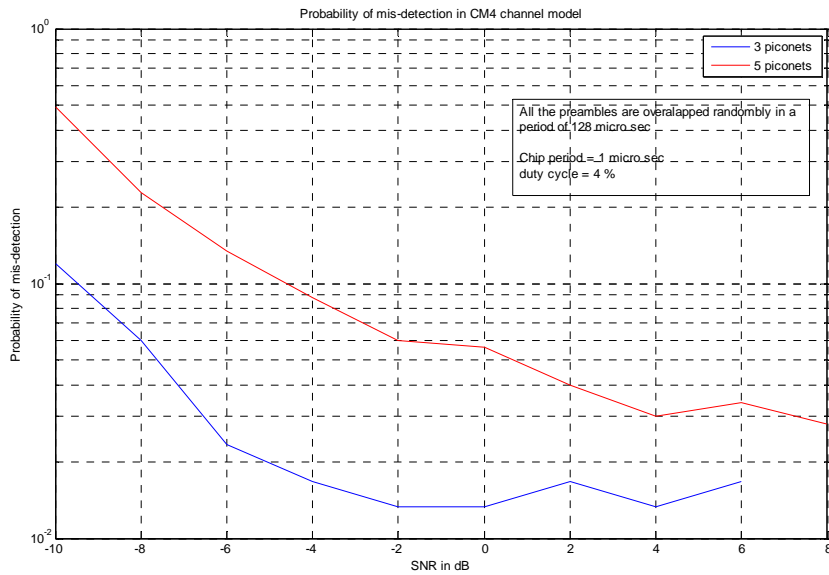
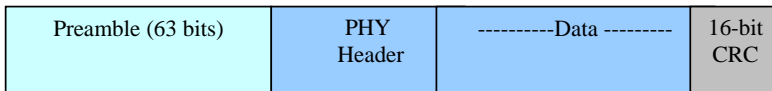

Figure 8.9. Mis-detection of the preamble for different SNR conditions at 0 dB SIR

9. Frame Format

The Frame format of the 802.15.6 consists of a 63 bit preamble, few bytes of PHY Header, Data, followed by a 16-bit CRC.



63 bit preamble will run at the duty cycle of the 1/32 with the chip period equal to that of the lowest data rate. The pulse shape can be Gaussian monocycle, raised cosine or chaotic, spanning 500 MHz bandwidth. PHY header comprises of information like the 4 bit Preamble Identifier to check the correct acquisition, 4-bits of information for Modulation and coding used for the data packet, 16 bit Length of the Payload, and 8 bit CRC (Header Check Sequence) to check the validity of the PHY header. The receiver will go on decoding the packet only after the PHY header validity is checked.

메모 [SR1]: Check!

10. PER Results and Link Budget

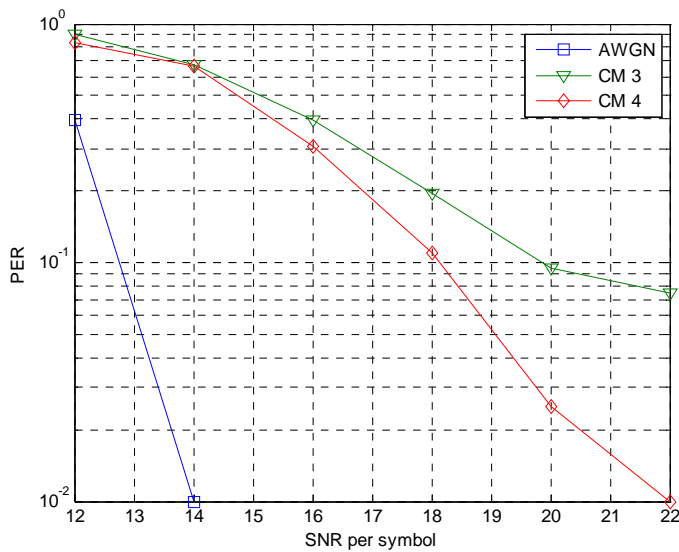

Figure 10.1: PER results for mod-type 3 modulation scheme

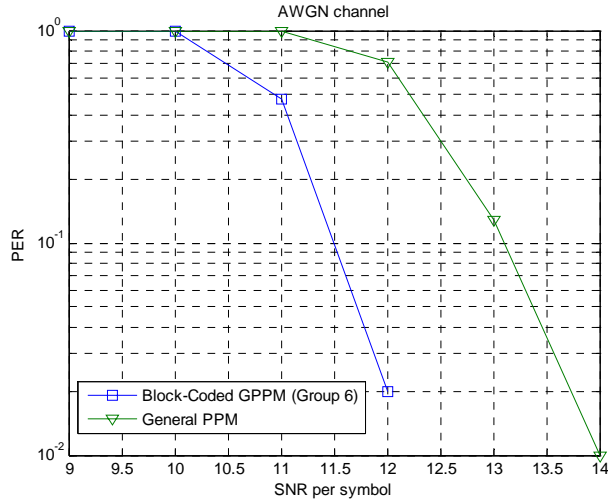

Figure 10.2: PER results for type 0,1,2 modulation scheme in AWGN channel

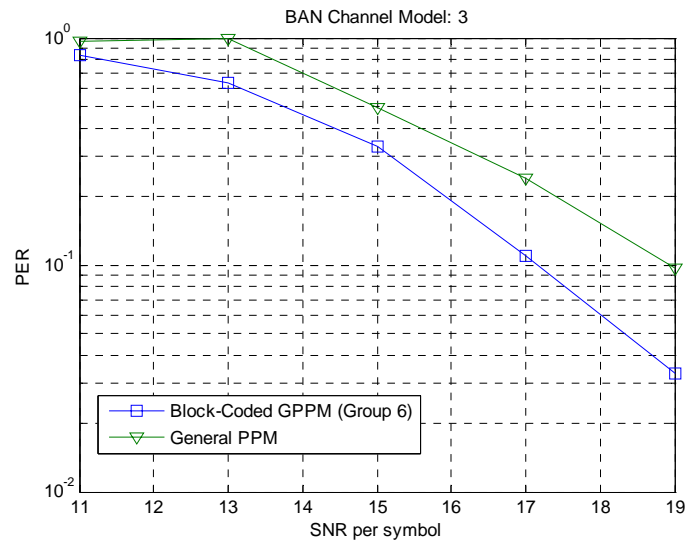

Figure 10.3: PER results for modulation type 0,1,2 modulation schemes for CM3.

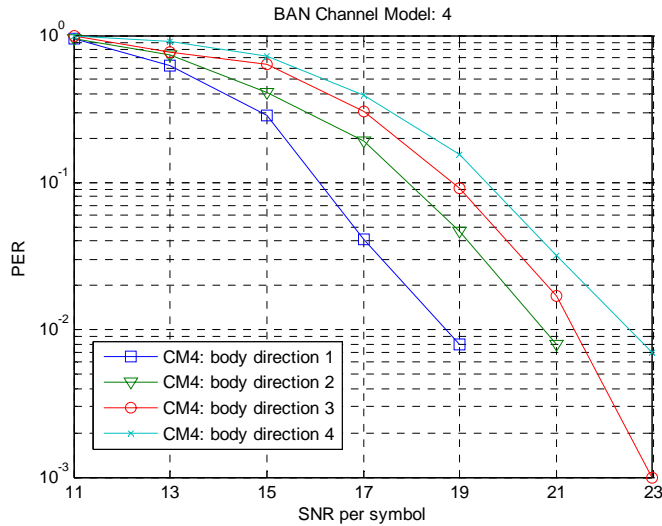

Figure 10.4: PER results for modulation type 0,1,2 modulation schemes for CM4.

Link Budget for 0,1,2 modulation schemes in AWGN channel

| Link Budget (AWGN) | | | | | |
|---|---------|--------|--------|--------|--------|
| Parameters | Unit | | | | |
| Symbol Rate [Rb] | MHz | 0.015 | 0.12 | 0.976 | 7.8 |
| Distance [d] | m | 5 | 5 | 5 | 5 |
| Bandwidth [BW] | MHz | 500 | 500 | 500 | 500 |
| Emission [E=dBm/MHz] | dBm/MHz | -59.4 | -50.4 | -41.3 | -41.3 |
| Average TX Power [Pt_avg=E+10log(BW)] | dBm | -32.4 | -23.4 | -14.3 | -14.3 |
| Pulse-on duration [Tp] | usec | 0.016 | 0.016 | 0.016 | 0.016 |
| Peak TX Power [Pt_peak = Pt_avg+10*log10(1/Rb*Tp)] | dBm | 3.8 | 3.8 | 3.8 | -5.3 |
| TX antenna gain [Gt] | dBi | 0.0 | 0.0 | 0.0 | 0.0 |
| Center frequency [fc] | GHz | 7.5 | 7.5 | 7.5 | 7.5 |
| Path loss d meter [L=20log(4pi*fc/c)+20log(d)] for AWGN and CM4 | dB | 63.9 | 63.9 | 63.9 | 63.9 |
| RX antenna gain [Gr] | dBi | 0.0 | 0.0 | 0.0 | 0.0 |
| RX power [Pr=Pt_avg+Gt+Gr-L] | dBm | -96.4 | -87.3 | -78.2 | -78.2 |
| Receiver AWGN noise floor | dBm | -132.2 | -123.2 | -114.1 | -105.1 |

We have limited the Tx Power to reduce the power Consumption. Actual Link margin for 10 kbps and 100 kbps can be higher by 18 and 9 dB respectively

| | | | | | |
|---|-----|--------|--------|--------|-------|
| [$N=-174+10\log(BW)$] | | | | | |
| RF noise figure [Nf] | dB | 6.0 | 6.0 | 6.0 | 6.0 |
| Average noise power [Pn=N+Nf] | dBm | -126.2 | -117.2 | -108.1 | -99.1 |
| Minimum SNR per symbol [S] | dB | 11.5 | 11.5 | 11.5 | 13.0 |
| Implementation loss [I] | dB | 3.0 | 3.0 | 3.0 | 3.0 |
| Link Margin [LM=Pr-Pn-S-I] | dB | 15.4 | 15.4 | 15.4 | 4.8 |
| Proposed Min. Rx Sensitivity Level [Pmin] | dBm | -111.7 | -102.7 | -93.6 | -83.1 |

| Link Budget (CM3 Pathloss) | | | | | |
|---|---------|--------|--------|--------|-------------|
| Parameters | Unit | | | | |
| Symbol Rate [Rb] | MHz | 0.015 | 0.12 | 0.976 | 7.8 |
| Distance [d] | m | 3 | 3 | 3 | 3 |
| Bandwidth [BW] | MHz | 500 | 500 | 500 | 500 |
| Emission [E=dBm/MHz] | dBm/MHz | -59.4 | -50.4 | -41.3 | -41.3 |
| Average TX Power [Pt_avg=E+10log(BW)] | dBm | -32.4 | -23.4 | -14.3 | -14.3 |
| Pulse-on duration [Tp] | usec | 0.016 | 0.016 | 0.016 | 0.016 |
| Peak TX Power [Pt_peak = Pt_avg+10*log10(1/Rb*Tp)] | dBm | 3.8 | 3.8 | 3.8 | -5.3 |
| TX antenna gain [Gt] | dBi | 0.0 | 0.0 | 0.0 | 0.0 |
| Path loss d meter [L=19.2*log10(d*1000)+3.38] for CM3 | dB | 70.1 | 70.1 | 70.1 | 64.1(@1.5m) |
| RX antenna gain [Gr] | dBi | 0.0 | 0.0 | 0.0 | 0.0 |
| RX power [Pr=Pt_avg+Gt+Gr-L] | dBm | -102.6 | -93.6 | -84.5 | -78.5 |
| Receiver AWGN noise floor [N=-174+10log(BW)] | dBm | -132.2 | -123.2 | -114.1 | -105.1 |
| RF noise figure [Nf] | dB | 6.0 | 6.0 | 6.0 | 6.0 |
| Average noise power [Pn=N+Nf] | dBm | -126.2 | -117.2 | -108.1 | -99.1 |
| Minimum SNR per symbol [S] | dB | 11.5 | 11.5 | 11.5 | 13.0 |
| Implementation loss [I] | dB | 3.0 | 3.0 | 3.0 | 3.0 |
| Link Margin [LM=Pr-Pn-S-I] | dB | 9.2 | 9.2 | 9.2 | 4.6 |
| Proposed Min. Rx Sensitivity Level [Pmin] | dBm | -111.7 | -102.7 | -93.6 | -83.1 |

11. Power Consumption

| Parameter | Value | Note | |
|----------------|-------------------------|-----------|------------------|
| Bit rate | 1 Mbps | | |
| Bandwidth | 500 MHz | | |
| Rx Sensitivity | -93.6 dBm | @ PER 10% | |
| Tx | Chaotic generator | 9 mW | |
| | Power amp | 18 mW | |
| | modulator | 1.8 mW | |
| Rx | Low Noise Amp | 7 mW | |
| | Energy detector | 4 mW | 50mV sensitivity |
| | Variable Gain amplifier | 8 mW | |
| | | | |

12. Self Evaluation

| Parameter | Addressed | Comments |
|-----------------------------|-----------|--------------------------|
| Range | Yes | 300 m |
| Power consumption | Yes | Below 25 mW for 1 Mbps |
| Co-existence of 10 piconets | Yes | 16 piconets can co-exist |
| Scalability | Yes | 10 kbps to 8 Mbps |
| PER of 10 % | Yes | |
| Link Budget | Yes | |
| Regulatory | Yes | 7.25 to 8.5 GHz |

13. Summary

The proposal contains the details of the G-PPM modulation scheme and the co-existence in the UWB spectrum. We have shown how this proposal will meet different criteria required for the body area networks by IEEE 802.15.6 Task group.

This proposal excels in achieving the range of 3m required for the operation of body area networks and has considerable scalability of data rates from few tens of kbps to 10 Mbps. It also demonstrates how we can achieve the co-existence of 10 different networks.

14. References

- **TG6 Technical Requirements Document**, <https://mentor.ieee.org/802.15/dcn/08/15-08-0644-09-0006-tg6-technical-requirements-document.doc>, IEEE, 2008
- **802.15-08-0780-05-0006-Channel model document of TG6**
- **TG6 Channel model document**, <https://mentor.ieee.org/802.15/file/08/15-08-0780-09-0006-tg6-channel-model.pdf>, IEEE, 2008
- **Amal Ekbal, Jun Shi, Zhanfeng Jia, Jason Ellis, Channel model considerations for IEEE 802.15.6**, <https://mentor.ieee.org/802.15/dcn/08/15-08-0792-00-0006-channel-model-updates-for-802-15-6.ppt>, IEEE 2008
- **“15-09-0141-01-0006-preliminary-wban-proposal-using-ir-uwband-etri.pdf”**
Cheolhyo Lee¹ et al.
- **“15-09-0171-04-0006-samsung-preliminary-phy-proposal.ppt”**, Kiran Bynam et al
- **Sang-Min Han, Mi-Hyun Son, Yong-Hwan Kim, and Seong-Soo Lee, “Low-Rate Chaotic UWB Transceiver System Based on IEEE 802.15.4a”**, 36th European Microwave Conference, pp.1837-1840, Sep. 2006
- **K. Lee, S. Kyeong, J. Kim, Y. Kim and H. Park, “The Chaotic On-off Keying with Guard Interval for Ultra-Wideband Communication”**, IEEE VTS Asia Pacific Wireless Communications Symposium, Daejeon, Korea, August 2006
- **Sang-Min Han, O. Popov and A.S. Dmitriev, “Flexible Chaotic UWB Communication System With Adjustable Channel Bandwidth in CMOS Technology”**, IEEE Transactions on Microwave Theory and Techniques, Vol. 56, Issue 10, pp.2229-2236, Oct. 2008