

Project: IEEE P802.15 Working Group for Wireless Personal Area Networks (WPANs)

Submission Title: [ETRI & Samsung PHY proposal to 802.15.6]

Date Submitted: [4 May, 2009]

Source: [Kiran Bynam(1), Noh-Gyoung Kang(1), Chihong Cho(1), Seung-Hoon Park(1), Sridhar Rajagopal(1), Eun Tae Won(1), Giriraj Goyal(1), Mi-Kyung Oh(2), Hyung Soo Lee(2), Cheol-Hyo Lee(2), Jae-Young Kim(2), Jae-Ho Hwang(3), Jae-Myung Kim(3)]

[(1) Samsung Electronics, (2) ETRI, (3) Inha Univ.]

Re: [Contribution to IEEE 802.15.6 Meeting, May 2009]

Abstract: [PHY proposal for 802.15.6 Requirements.]

Purpose: [To be considered in IEEE 802.15.6]

Notice: This document has been prepared to assist the IEEE P802.15. It is offered as a basis for discussion and is not binding on the contributing individual(s) or organization(s). The material in this document is subject to change in form and content after further study. The contributor(s) reserve(s) the right to add, amend or withdraw material contained herein.

Release: The contributor acknowledges and accepts that this contribution becomes the property of IEEE and may be made publicly available by P802.15.

ETRI & Samsung PHY proposal to 802.15.6

ETRI & Samsung Electronics
May, 2009

Contents

- TRD Requirements
- Proposal Scope
- Concept of Proposal
- Modulation (Block-Coded GPPM)
- PHY Scalability
- Pulse shapes
- PHY Frame Structure
- Link Budget
- Band Plan
- Co-existence
- Preamble Design
- Power Efficiency
- Conclusions
- Comparison Criteria
- References

Requirements

- 10 kbps to 10 Mbps
- Range of 3 m at lowest mandatory rate
- 10 piconet co-existence at the lowest mandatory data rate
- Low Power & complexity
- Regulatory Compliance

Proposal Scope

- On-body applications
- Data rate range of 10 kbps to 10 Mbps
- On-body to air (CM4)
- On-body to On-Body (CM3)
- UWB Higher band (7.25 to 8.5 GHz) to have the global regulatory compliance
- Low Power

Key Aspects of Proposal

- UWB non-coherent receiver
- No definition of specific pulse shape
- Short Kasami code based preamble
- Block-Coded Group PPM (BC-GPPM)

System Block Diagram

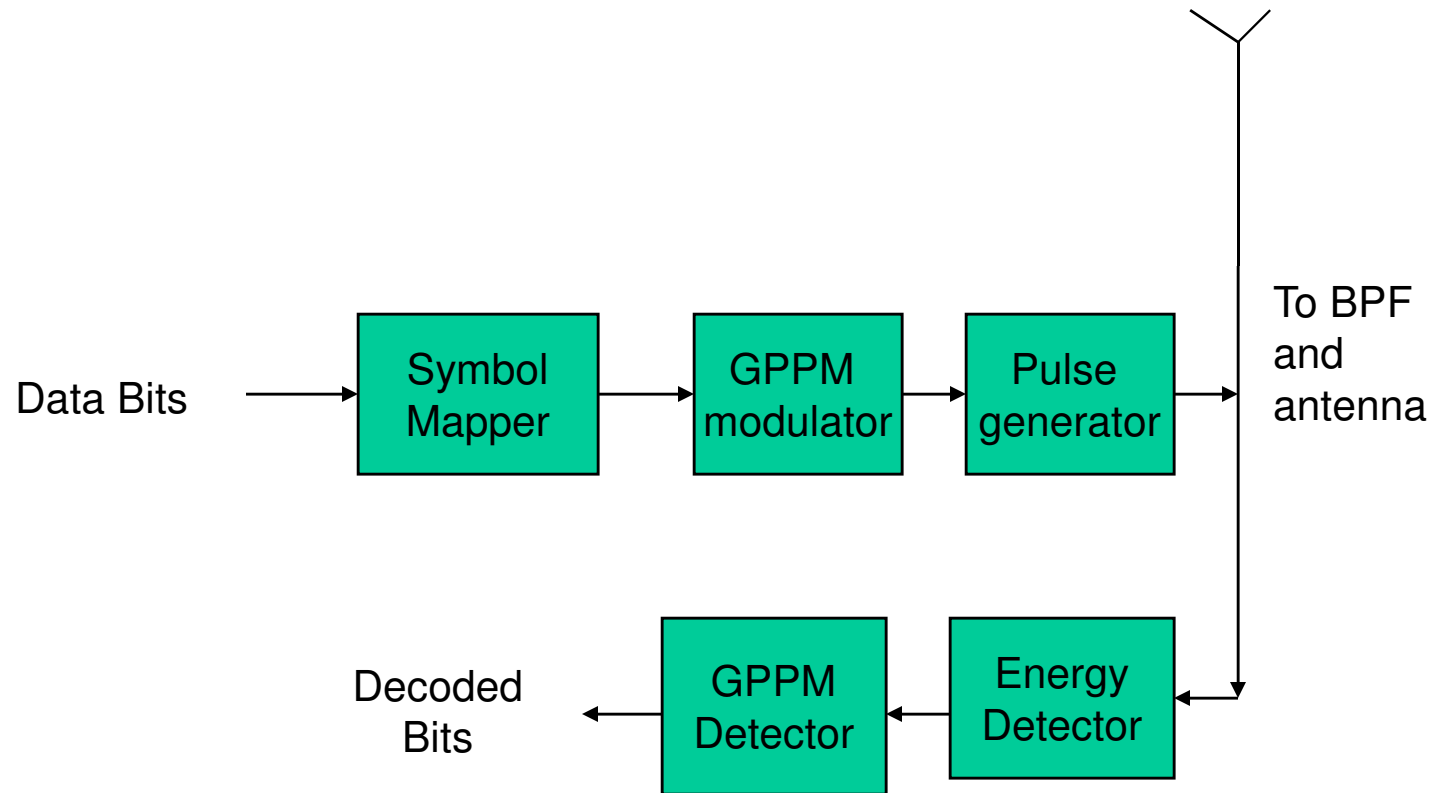

Concept of Group PPM (GPPM)

- Example: 3-symbol grouping
 - 3 time-slots out of 6 time-slots are occupied by pulse → total 20 cases !

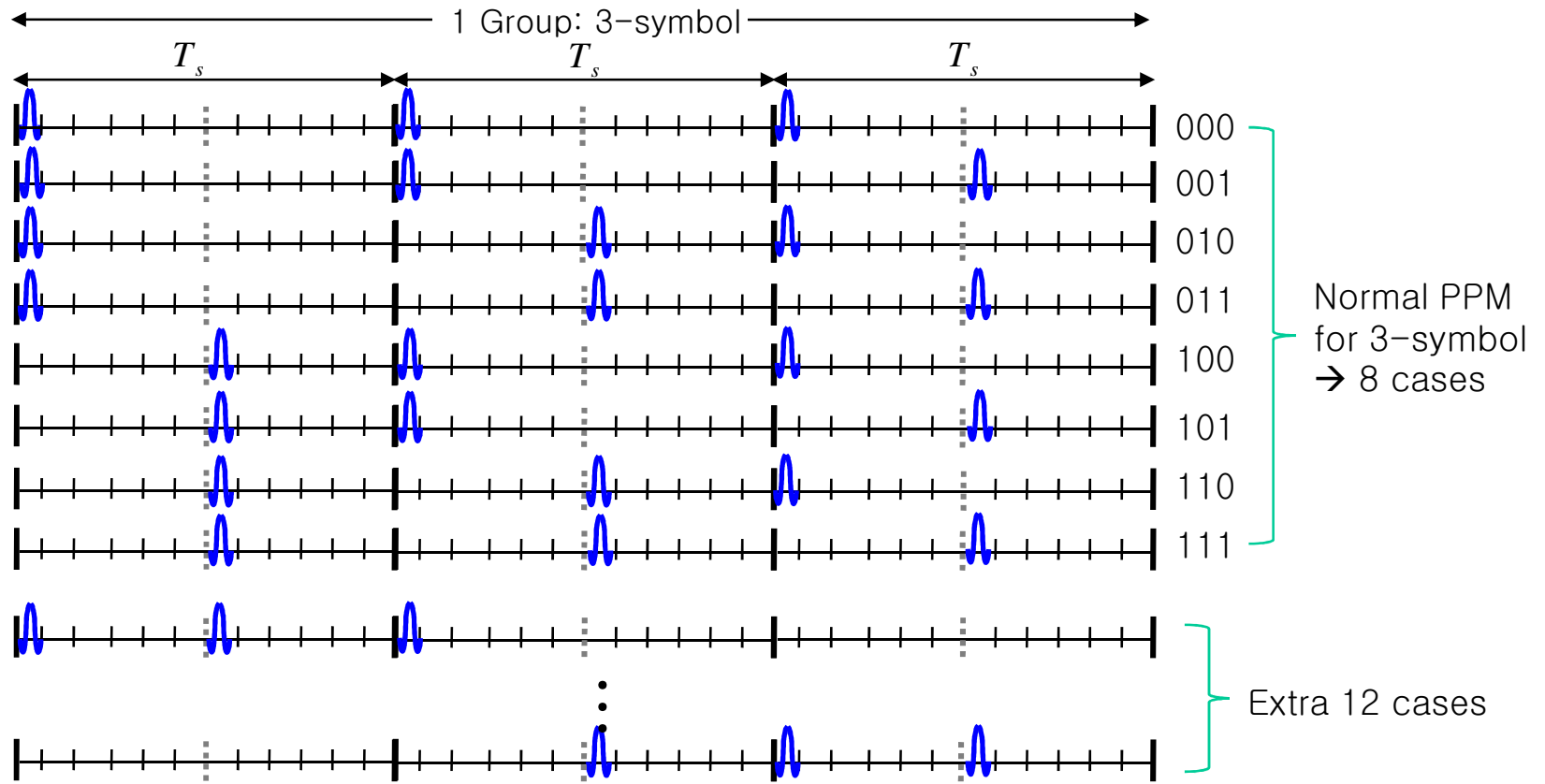

Block-Coded GPPM with group 3

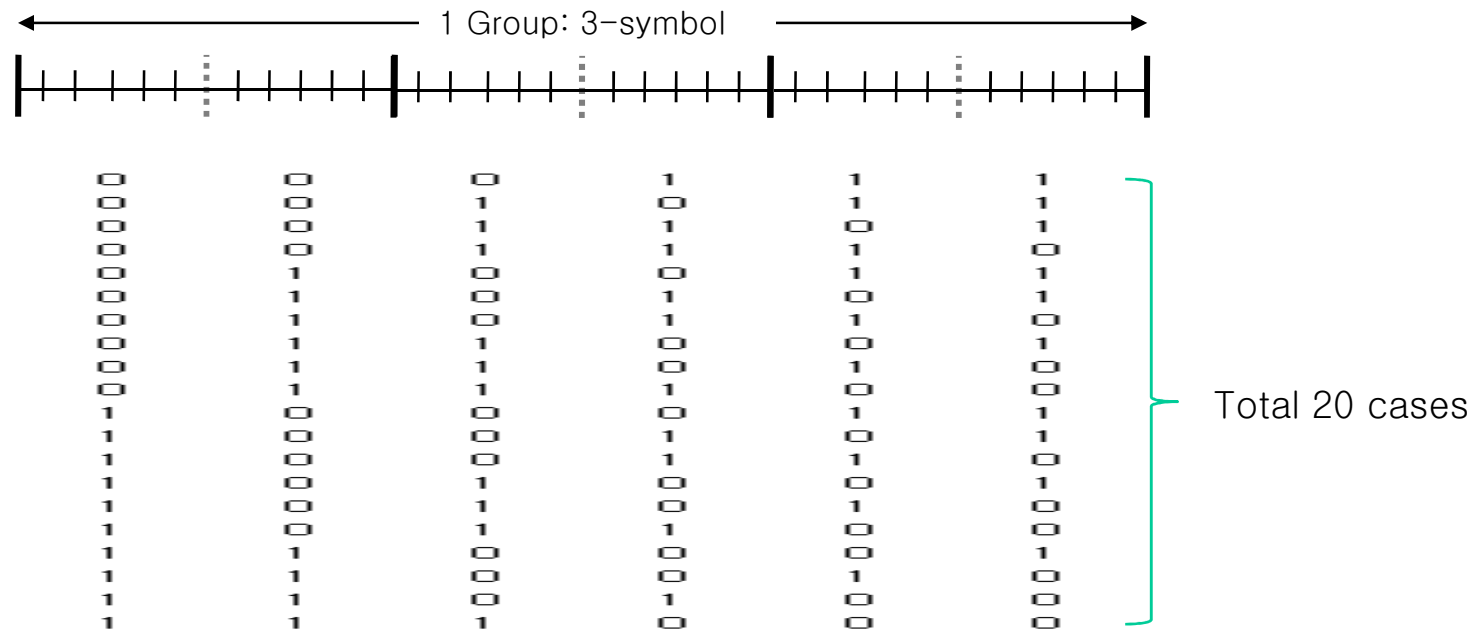

- Increased number of cases by 3-symbol grouping
 - Option 1: 16 cases for transmitting 4 bits during 3-symbol duration
 - Option 2: 8 cases with error correction capability for transmitting 3 bits during 3-symbol duration → Block-Coded GPPM (BC-GPPM)

Detection of BC-GPPM with group 3

- Simple detection algorithm for 3 BC-GPPM

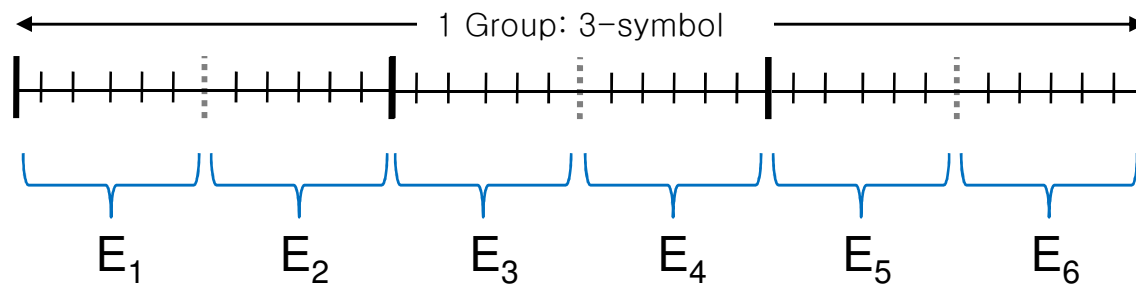

EX) Hard decision from energy detection signals $\{E_1, E_2, E_3, E_4, E_5, E_6\}$
 The largest 3 \rightarrow 1
 The others 3 \rightarrow 0



Code set (8 cases)					
0	0	0	1	1	1
0	0	1	0	1	1
0	1	1	0	0	1
0	0	1	1	0	1
0	0	1	1	1	0
1	0	1	0	1	0
1	1	0	1	0	0
0	1	0	0	1	1



Bit de-mapping		
0	0	0
0	0	1
0	1	1
0	1	0
1	1	0
1	1	1
1	0	1
1	0	0

Block-Coded GPPM with group 6

- Why 6 BC-GPPM?
 - PER performance: 1Mbps@AWGN

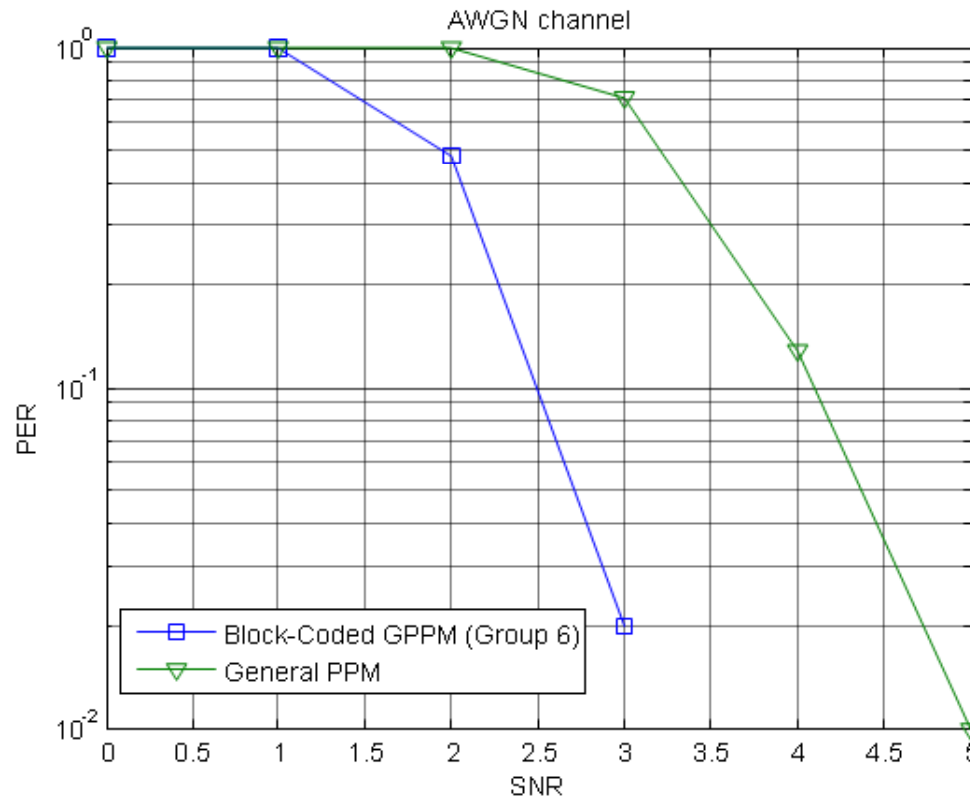

Ex: Block code set(64) for 6 BC-GPPM

```
0 0 0 0 0 0 1 1 1 1 1 1
0 0 0 0 1 1 0 1 1 0 1 1
0 0 0 1 1 1 0 0 0 1 1 1
0 0 0 0 1 1 1 0 1 1 0 1
0 0 0 1 1 1 1 1 1 0 0 0
0 0 0 0 1 1 1 1 0 1 1 0
0 1 1 0 0 1 1 1 0 1 0 0
0 0 1 0 0 1 0 1 0 1 1 1
0 1 1 0 0 1 0 0 1 0 1 1
0 0 0 1 0 1 1 0 1 0 1 1
0 0 0 1 0 1 0 1 1 1 0 1
1 1 0 1 0 0 0 1 1 0 0 1
0 0 1 1 0 0 0 1 1 0 1 1
1 0 1 0 1 0 0 1 0 0 1 1
0 0 0 1 1 0 1 1 0 0 1 1
0 0 0 1 1 0 0 1 1 1 1 0
0 1 1 1 1 0 0 0 1 1 0 0
0 0 1 0 1 0 0 0 1 1 1 1
0 0 1 0 0 1 1 0 1 1 1 0
0 0 1 0 0 1 1 1 1 0 0 1
0 0 1 0 1 0 1 1 0 1 0 1
1 0 1 1 0 0 1 0 0 1 0 1
0 0 1 1 0 0 1 1 0 1 1 0
0 0 1 0 1 0 1 1 1 0 1 0
0 0 1 0 1 1 0 1 1 1 0 0
0 0 1 1 1 1 0 0 1 0 1 0
0 0 1 0 1 1 1 0 0 0 1 1
0 0 1 1 1 0 1 0 1 0 0 1
0 0 1 1 1 1 0 1 0 0 0 1
0 0 1 1 1 1 1 0 0 1 0 0
0 1 0 1 0 1 1 0 1 1 0 0
0 1 0 0 0 1 0 1 1 1 0
```

32

```
0 1 0 0 0 1 1 0 0 1 1 1
1 1 0 0 1 0 1 0 0 1 1 0
0 1 0 0 1 0 0 1 0 1 1 1
0 1 0 0 1 0 1 0 1 0 1 1
0 1 0 0 1 0 1 1 1 1 0 0
0 1 0 0 1 1 1 1 0 0 0 1
0 1 0 1 0 0 1 1 0 1 0 1
0 1 0 1 0 0 0 0 0 1 1 1
0 1 0 1 0 0 1 1 1 1 0 1
0 1 0 1 0 1 0 1 0 1 0 1
0 1 0 1 1 1 1 0 0 1 0 0
0 1 0 1 1 1 1 0 1 0 1 0
0 1 1 0 1 1 0 1 0 0 1 0
0 1 1 0 0 0 1 1 0 0 1 1
0 1 1 0 0 0 0 0 1 1 0 1
0 1 1 0 1 1 0 0 0 1 0 1
0 1 1 0 1 1 1 0 1 0 0 0
0 1 1 1 0 1 0 0 0 0 1 0
0 1 1 1 0 1 1 0 0 0 0 1
0 1 1 1 1 0 1 1 0 0 0 1
0 1 1 1 1 0 0 0 0 0 1 1
0 1 1 1 1 0 1 1 0 0 0 0
1 0 0 0 0 1 1 1 0 0 1 1
1 0 0 0 0 1 0 0 1 1 1 1
1 0 0 0 0 1 1 1 1 1 0 0
1 0 0 0 1 0 0 1 1 1 0 1
1 0 0 1 0 0 0 1 0 1 1 1
1 0 0 1 0 0 0 1 0 1 1 0
1 0 0 1 1 0 1 0 1 1 0 0
1 0 0 1 1 0 0 0 1 0 1 1
```

32

Block-Coded GPPM

- Advantages of BC-GPPM
 - Error correction capability without lowering the data rate.
 - Elimination of the FEC (e.g. RS code) which results in low-complexity transceiver architecture.

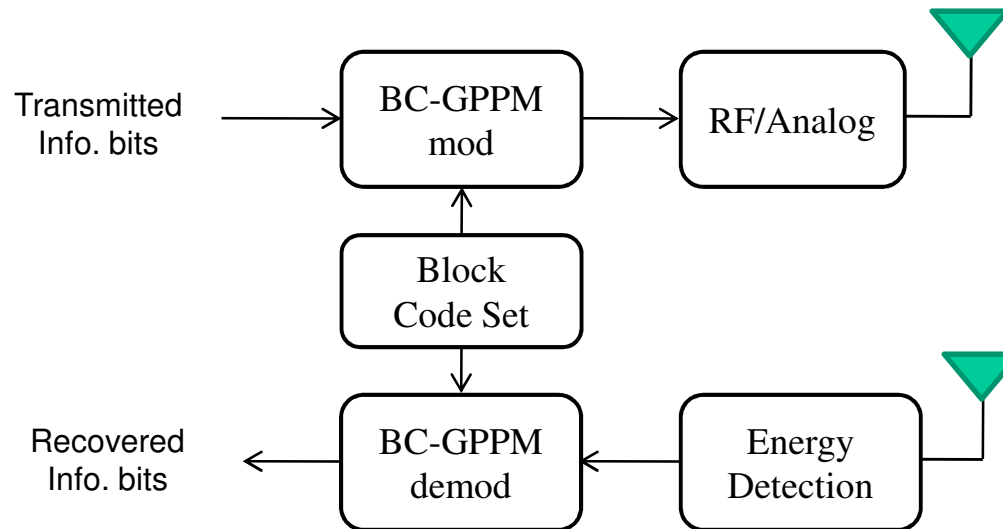

Data Scalability

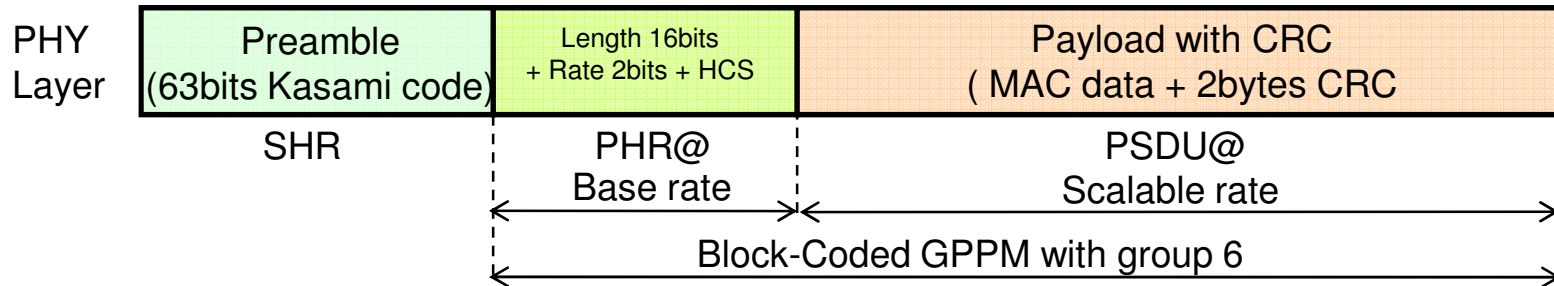

Mod-Type	Chip rate (Fc)	# of chips per symbol (Ncps)	# of burst positions per symbol (Nburst)	# of chips per burst (Ncpb)	# of chips for pulse-on duration (Ncpo)	Symbol Rate (MHz)	Bit Rate (Mbps)
00	500MHz	32768	32	1024	8	0.015	0.015
01	500MHz	4096	32	128	8	0.120	0.120
10	500MHz	512	32	16	8	0.976	0.976
11	500MHz	64	32	2	8	7.8	10.4

Data Scalability

- Symbol Structure Example: Mod-Type 2 (1Mbps)

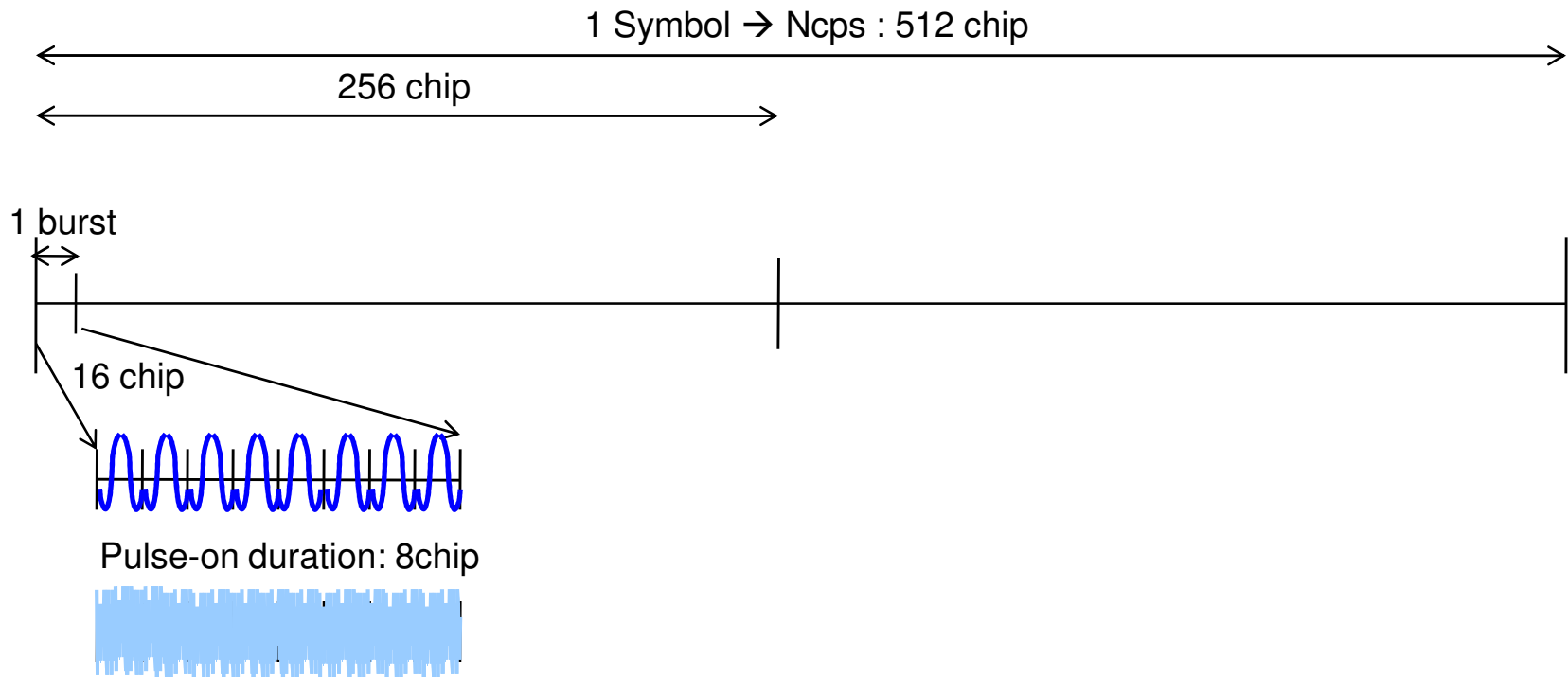

Scalable Data Rate

- Mod-Type 0~2
 - The number of chips for pulse-on duration is 8 and the energy per bit keeps unchanged for scalable data rate.
 - Therefore, link budgets are all same for Mod-Type 0~2.
 - Since block-coded GPPM with group 6 can transmit 6-bit during 6 symbol duration, the symbol rate and bit rate are same.
- Mod-Type 3
 - In order to meet 10Mbps data rate, block-coded GPPM with group 6 is designed to transmit 8-bit during 6 symbol duration which gives 10.4Mbps bit rate@7.8MHz symbol rate.
 - Among total 924 cases, 256 cases are used for 8-bit transmission and the others are used for block coding capability.

6 BC-GPPM for Mod-Type 0~2

- PER performance for 6 BC-GPPM
 - 0.976Mbps @ AWGN

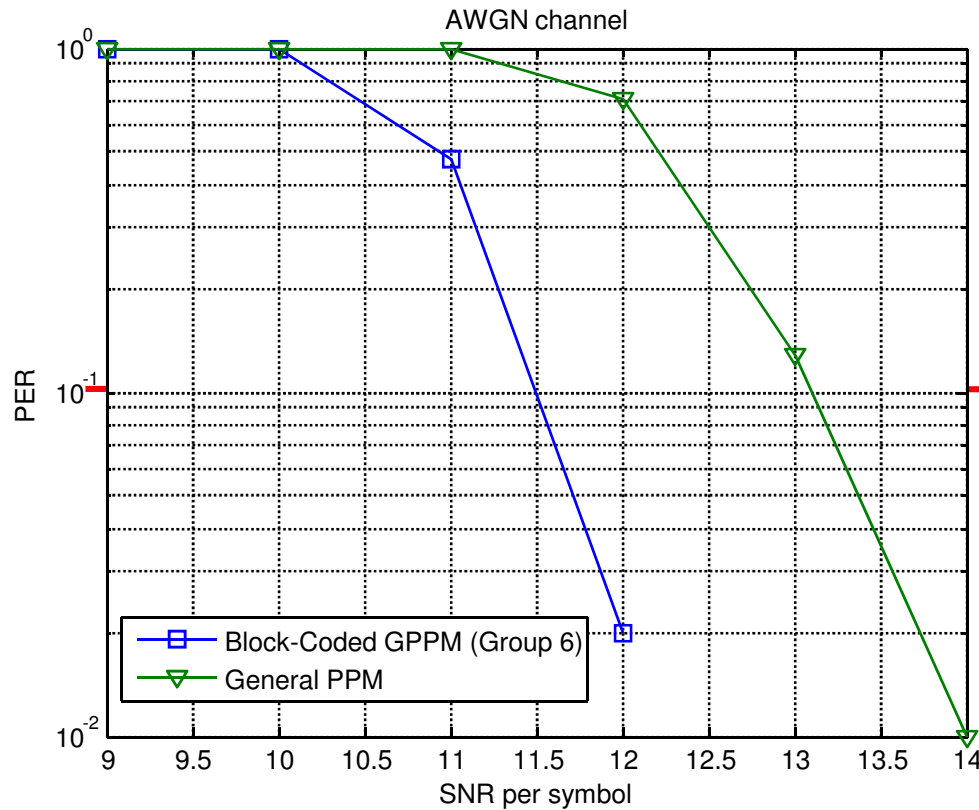

Minimum SNR at PER 10%

→ $SNR_{min} = 11.5$ dB for AWGN

6 BC-GPPM for Mod-Type 0~2

- PER performance for 6 BC-GPPM
 - 0.976Mbps @ CM3

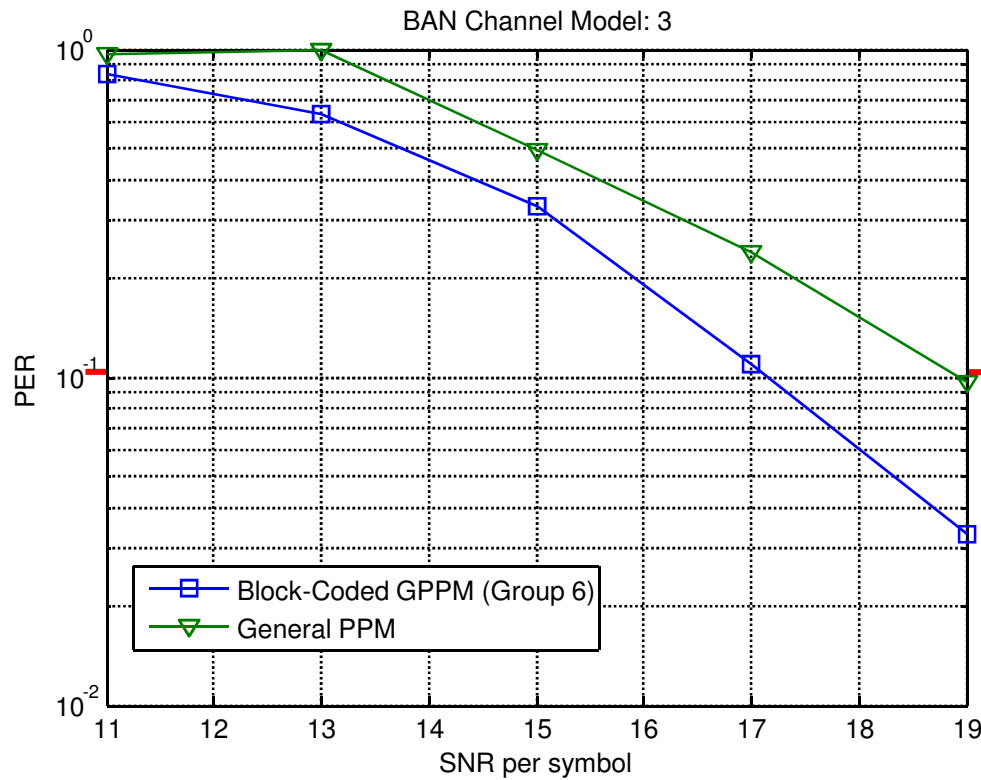

Minimum SNR at PER 10%

→ $SNR_{min} = 17$ dB for CM3

6 BC-GPPM for Mod-Type 0~2

- PER performance for 6 BC-GPPM
 - 0.976Mbps @ CM4(body direction 1,2,3,4)

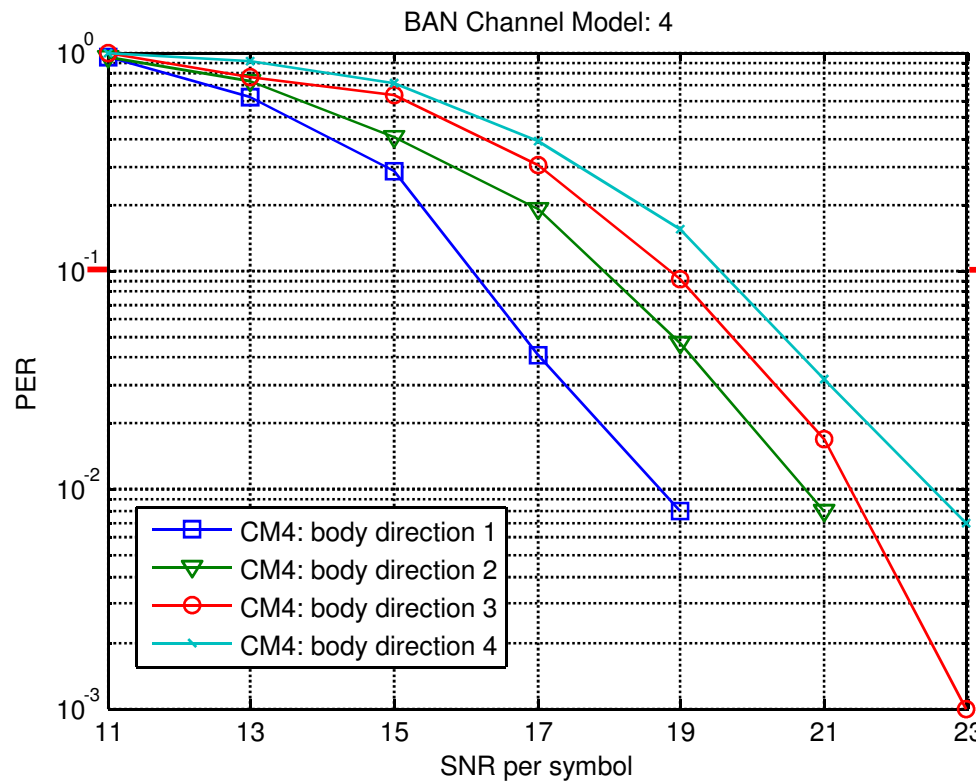

Minimum SNR at PER 10%

→ SNR_{min} = 20 dB for CM4

6 BC-GPPM for Mod-Type 3

- PER performance for 6 BC-GPPM
 - 10Mbps@ AWGN,CM3,CM4
 - LOS condition under CM3 and CM4 with body direction 1

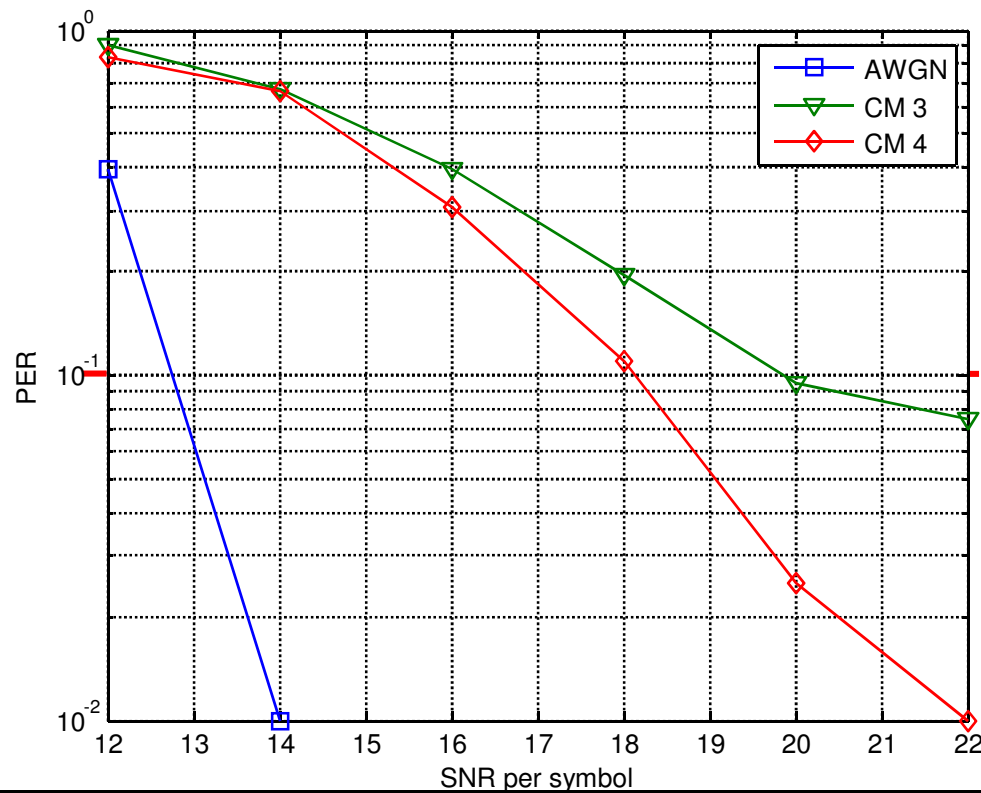

Minimum SNR at PER 10%

- SNR_{min} = 13 dB for AWGN
- SNR_{min} = 20 dB for CM3
- SNR_{min} = 18 dB for CM4

Chaotic Pulse Generator

- Block Diagram

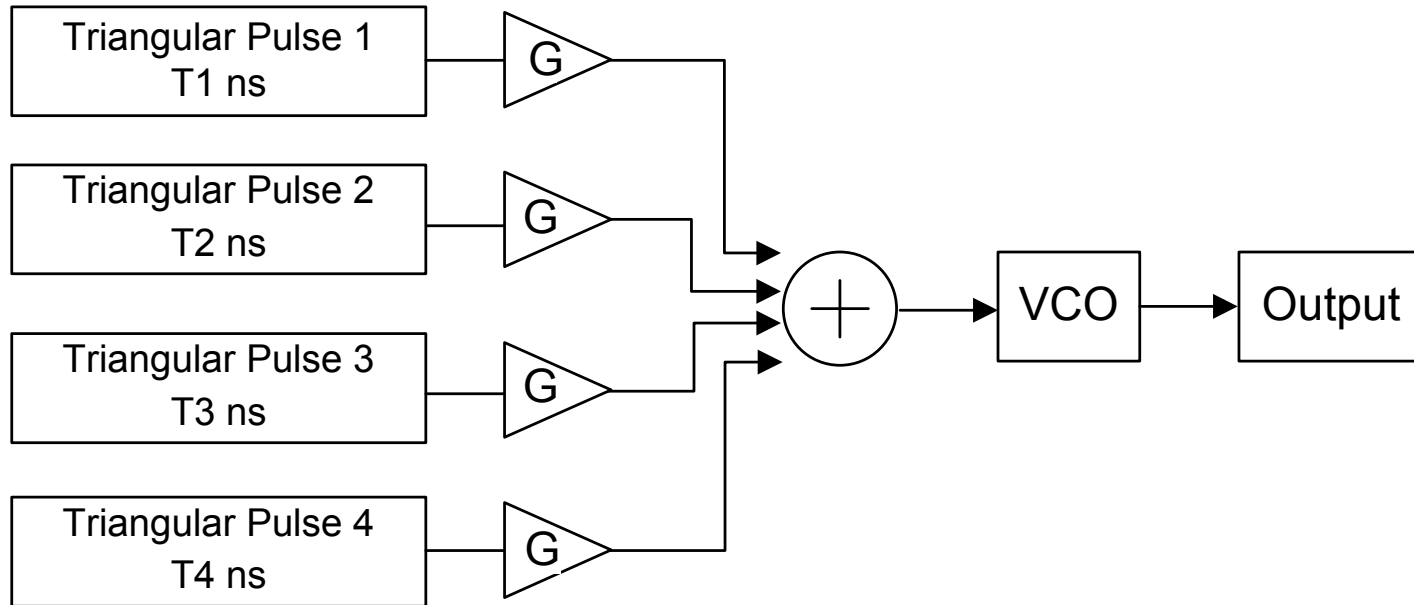

- Add four independent triangular pulses and use as VCO input.
- Saw-tooth pulses are possible as well as triangular pulses.

Using Triangular Waves

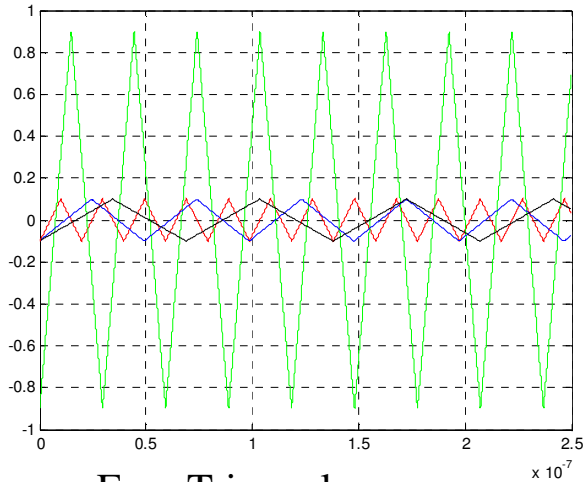

Four Triangular waves

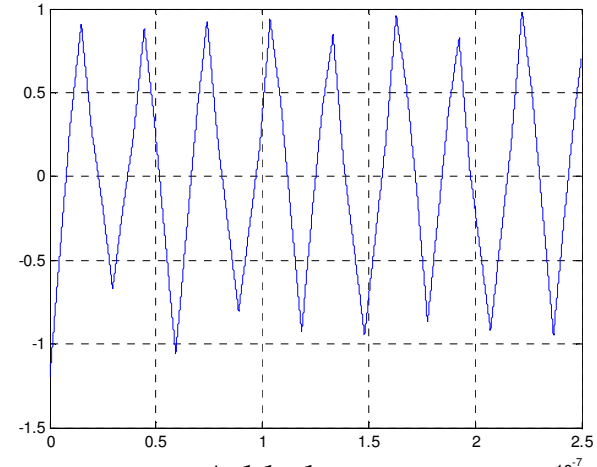

Added wave

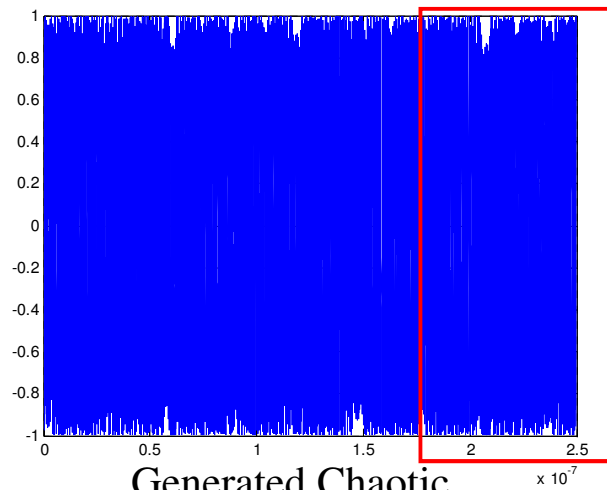

Generated Chaotic
Signal

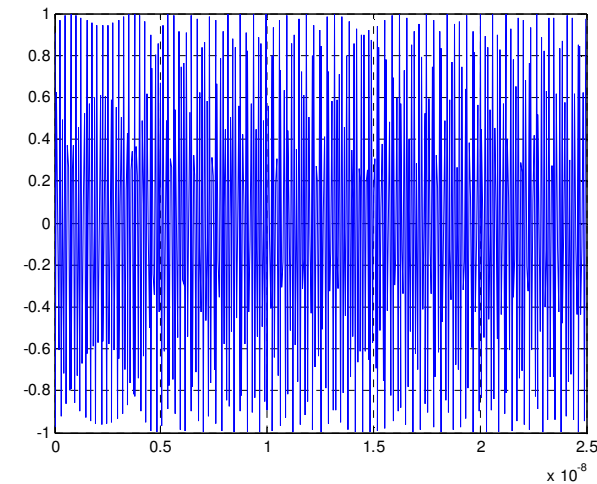

Generated Chaotic
Signal (Zoom)

Power Spectrums

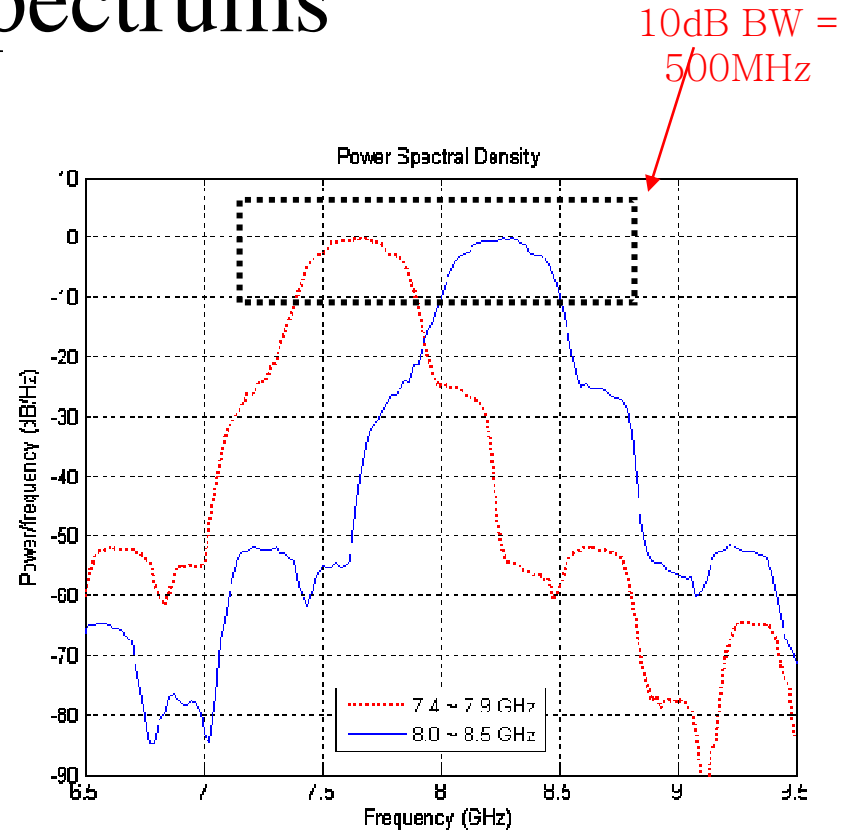
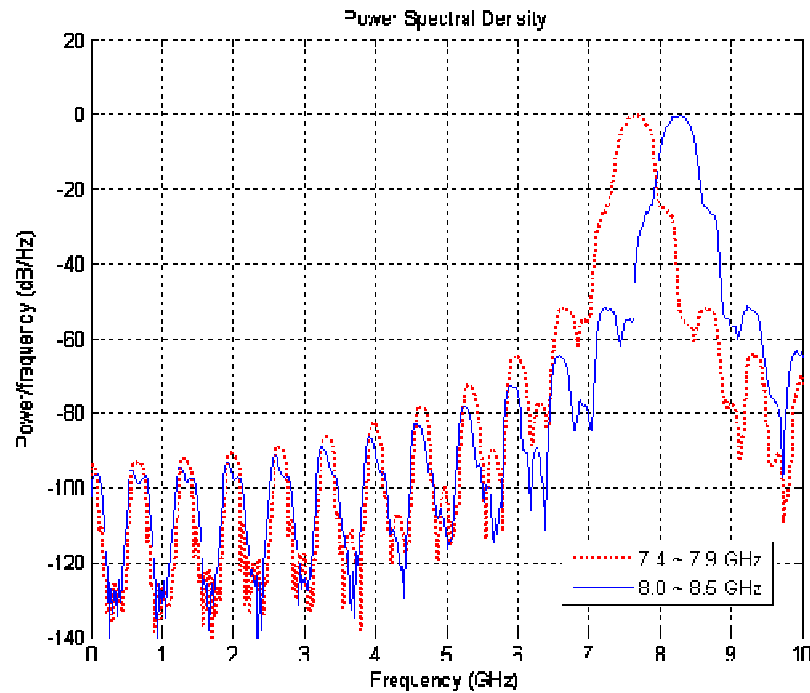

- Center frequency is linearly proportional to DC offset of VCO
 - DC offset = 0.315 : 7.4 – 7.9 GHz
 - DC offset = 0.49 : 8.0 – 8.5 GHz

Example: Impulse Generation

- Block Diagram

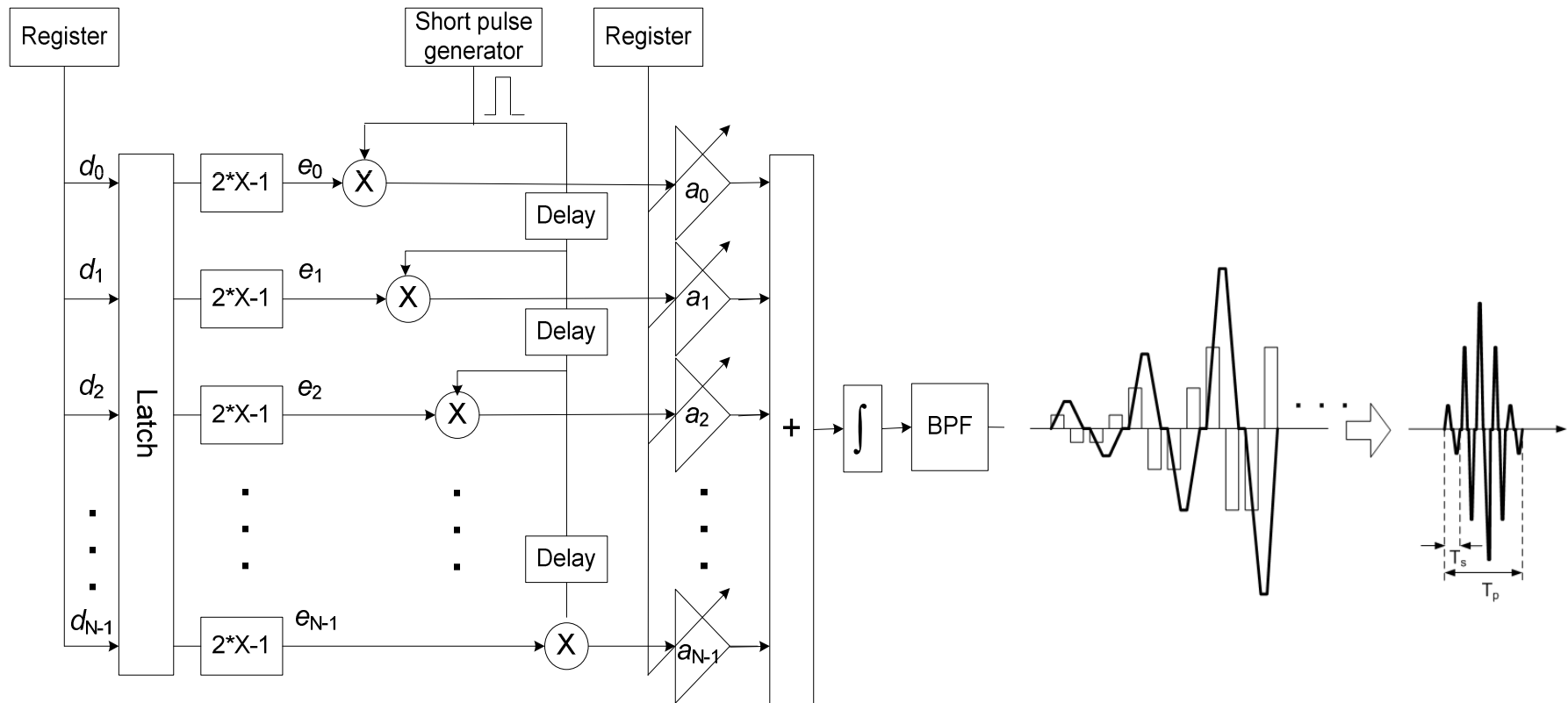

Example: Impulse Generation

- Impulse for CH2 and its spectrum

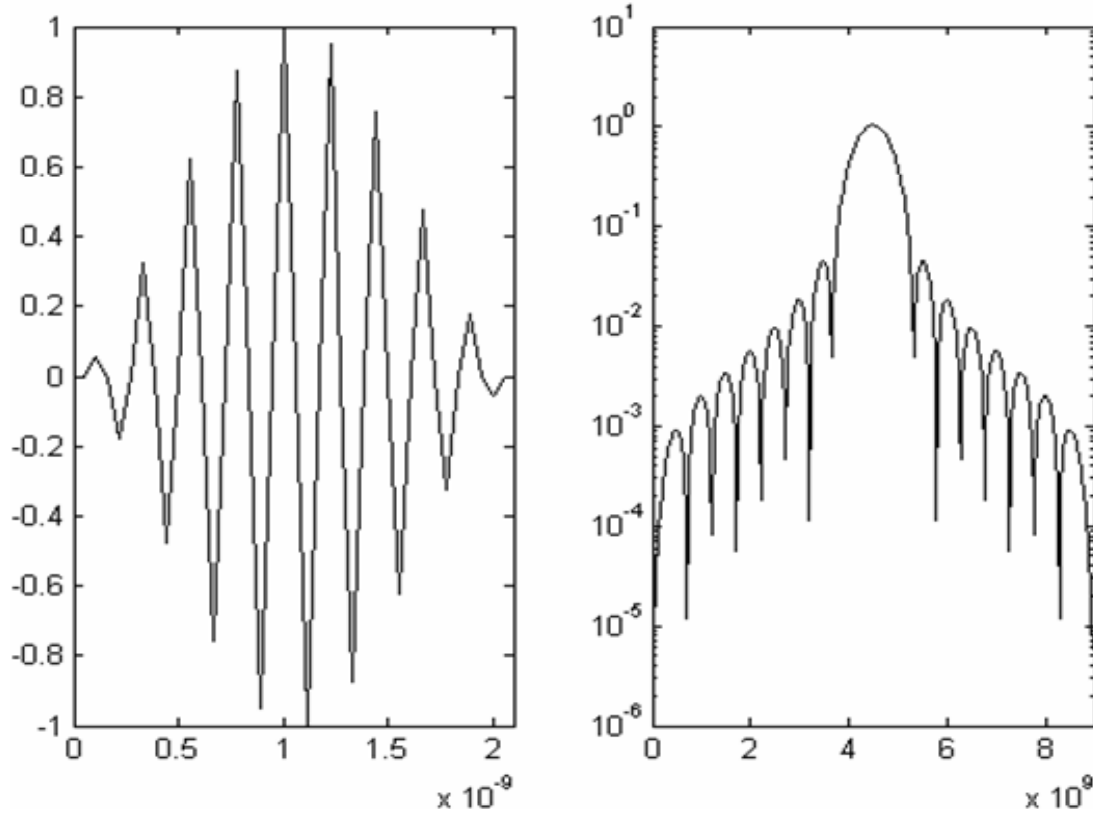

Link Budget (AWGN)

We have limited the Tx Power to reduce the power Consumption. Actual Link margin for 10 kbps and 100 kbps can be higher by 18 and 9 dB respectively

Link Budget (AWGN)					
Parameters	Unit				
Symbol Rate [Rb]	MHz	0.015	0.12	0.976	7.8
Distance [d]	m	5	5	5	5
Bandwidth [BW]	MHz	500	500	500	500
Emission [E=dBm/MHz]	dBm/MHz	-59.4	-50.4	-41.3	-41.3
Average TX Power [Pt_avg=E+10log(BW)]	dBm	-32.4	-23.4	-14.3	-14.3
Pulse-on duration [Tp]	usec	0.016	0.016	0.016	0.016
Peak TX Power [Pt_peak = Pt_avg+10*log10(1/Rb*Tp)]	dBm	3.8	3.8	3.8	-5.3
TX antenna gain [Gt]	dBi	0.0	0.0	0.0	0.0
Center frequency [fc]	GHz	7.5	7.5	7.5	7.5
Path loss d meter [L=20log(4pi*fc/c)+20log(d)] for AWGN and CM4	dB	63.9	63.9	63.9	63.9
RX antenna gain [Gr]	dBi	0.0	0.0	0.0	0.0
RX power [Pr=Pt_avg+Gt+Gr-L]	dBm	-96.4	-87.3	-78.2	-78.2
Receiver AWGN noise floor [N=-174+10log(BW)]	dBm	-132.2	-123.2	-114.1	-105.1
RF noise figure [Nf]	dB	6.0	6.0	6.0	6.0
Average noise power [Pn=N+Nf]	dBm	-126.2	-117.2	-108.1	-99.1
Minimum SNR per symbol [S]	dB	11.5	11.5	11.5	13.0
Implementation loss [I]	dB	3.0	3.0	3.0	3.0
Link Margin [LM=Pr-Pn-S-I]	dB	15.4	15.4	15.4	4.8
Proposed Min. Rx Sensitivity Level [Pmin]	dBm	-111.7	-102.7	-93.6	-83.1

Link Budget (CM3 Path)

We have limited the Tx Power to reduce the power Consumption. Actual Link margin for 10 kbps and 100 kbps can be higher by 18 and 9 dB respectively

Link Budget (CM3 Pathloss)					
Parameters	Unit				
Symbol Rate [Rb]	MHz	0.015	0.12	0.976	7.8
Distance [d]	m	3	3	3	3
Bandwidth [BW]	MHz	500	500	500	500
Emission [E=dBm/MHz]	dBm/MHz	-59.4	-50.4	-41.3	-41.3
Average TX Power [Pt_avg=E+10log(BW)]	dBm	-32.4	-23.4	-14.3	-14.3
Pulse-on duration [Tp]	usec	0.016	0.016	0.016	0.016
Peak TX Power [Pt_peak = Pt_avg+10*log10(1/Rb*Tp)]	dBm	3.8	3.8	3.8	-5.3
TX antenna gain [Gt]	dBi	0.0	0.0	0.0	0.0
Path loss d meter [L=19.2*log10(d*1000)+3.38] for CM3 (section 8.2.7.A of channel model document)	dB	70.1	70.1	70.1	64.1(@1.5m)
RX antenna gain [Gr]	dBi	0.0	0.0	0.0	0.0
RX power [Pr=Pt_avg+Gt+Gr-L]	dBm	-102.6	-93.6	-84.5	-78.5
Receiver AWGN noise floor [N=-174+10log(BW)]	dBm	-132.2	-123.2	-114.1	-105.1
RF noise figure [Nf]	dB	6.0	6.0	6.0	6.0
Average noise power [Pn=N+Nf]	dBm	-126.2	-117.2	-108.1	-99.1
Minimum SNR per symbol [S]	dB	11.5	11.5	11.5	13.0
Implementation loss [I]	dB	3.0	3.0	3.0	3.0
Link Margin [LM=Pr-Pn-S-I]	dB	9.2	9.2	9.2	4.6
Proposed Min. Rx Sensitivity Level [Pmin]	dBm	-111.7	-102.7	-93.6	-83.1

Regulation: Band Plan

- Low band and high band plan

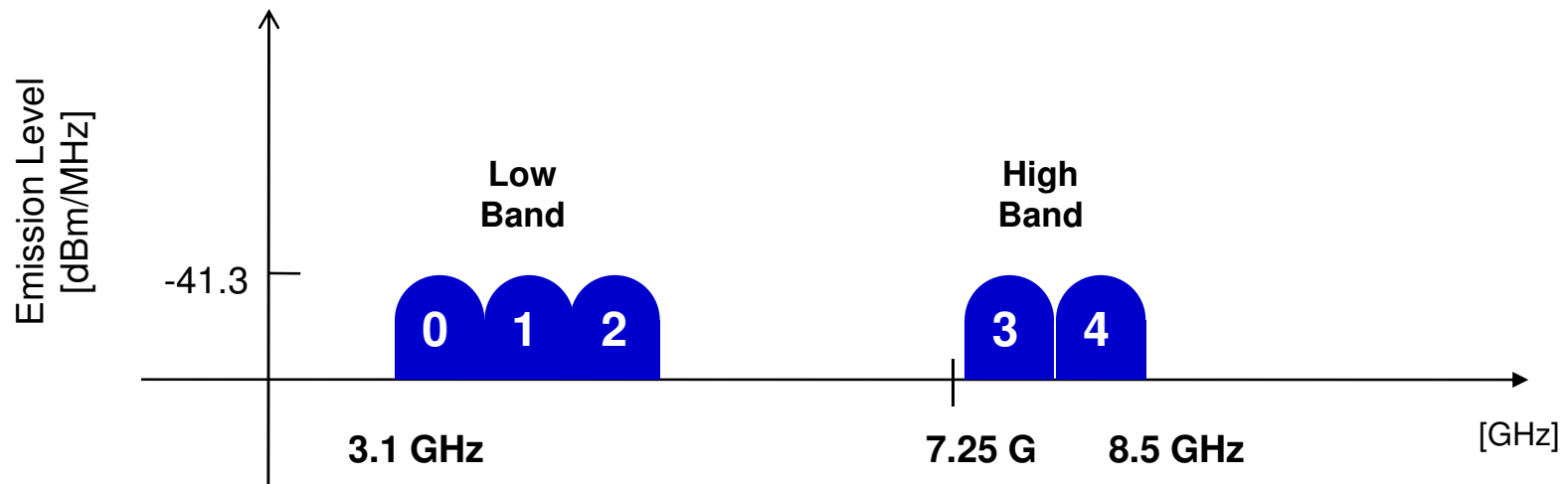

Band Plan without DAA

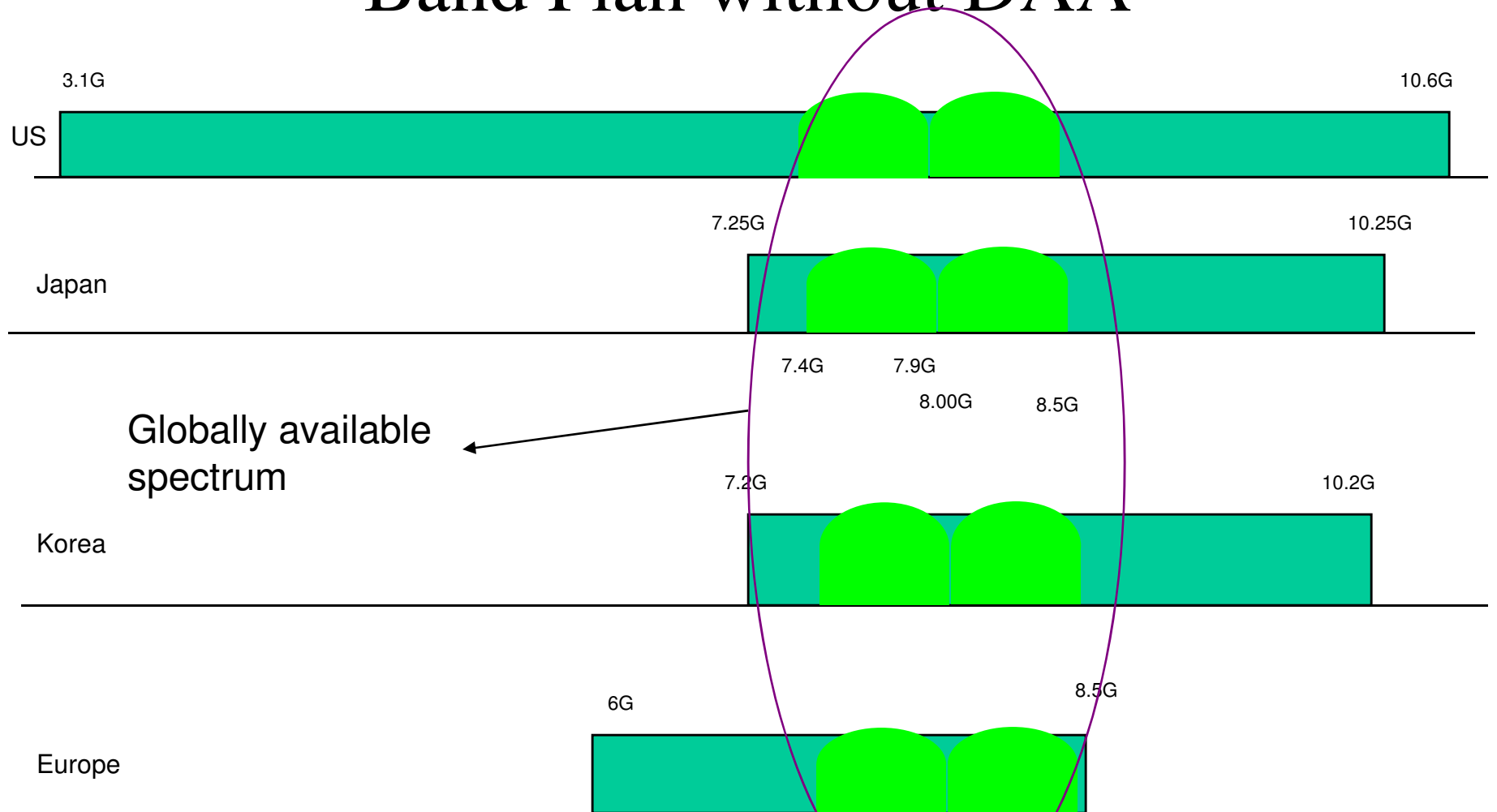

5 SOP interfering environment

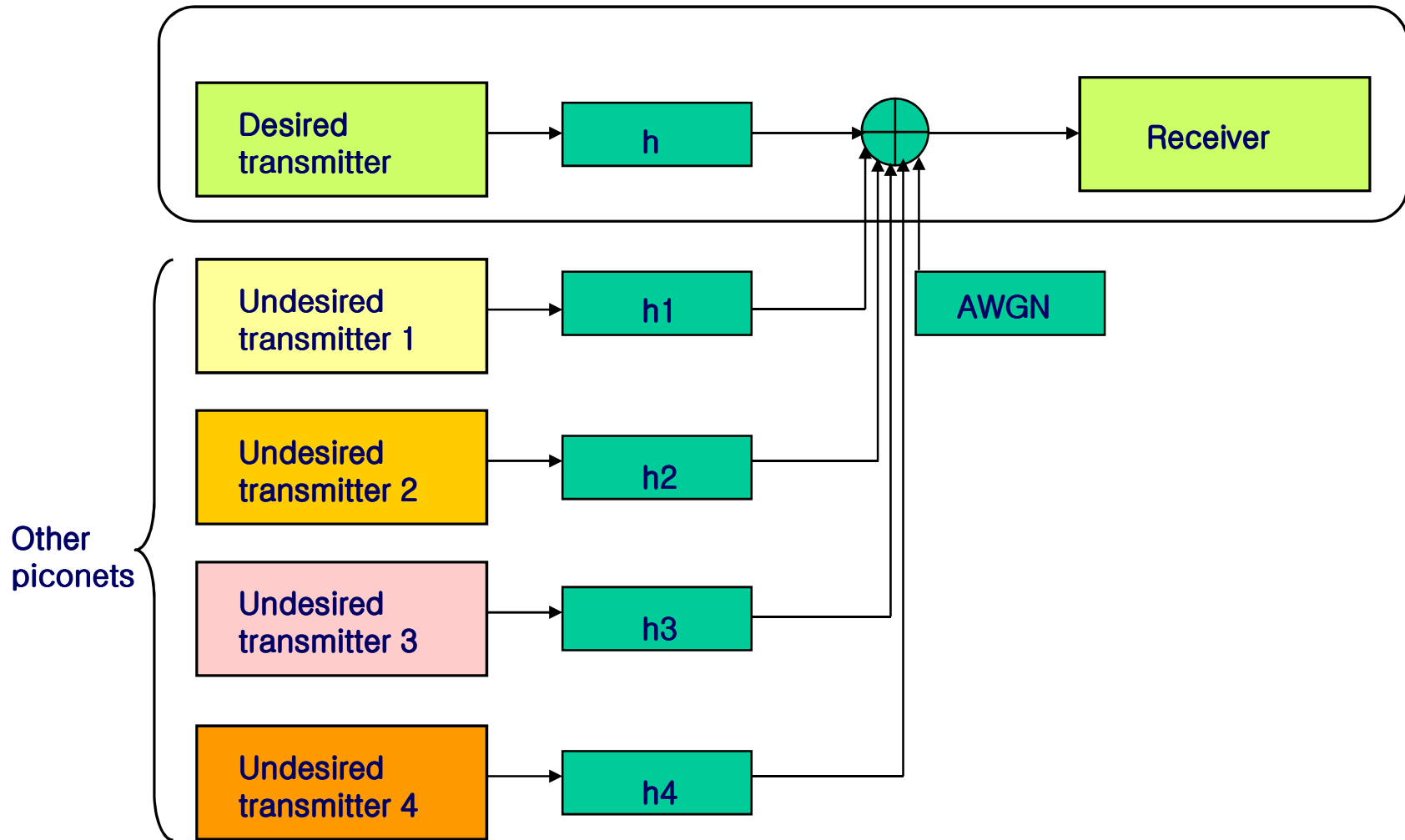

SOP Performance

- PER performance
 - 1Mbps@ AWGN,CM3,CM4(body direction 1)

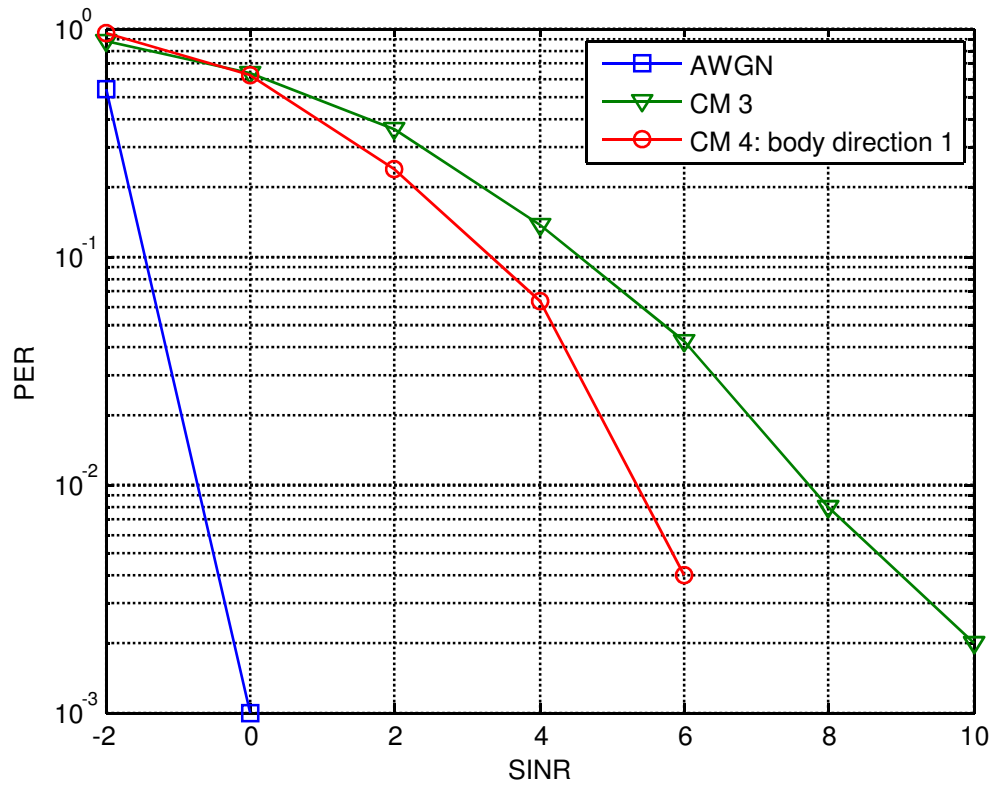

Preamble Design

- 8 sequences found for up to 8 piconets using Kasami codes
- Length 63 Kasami short sequences
- On/Off Keying with Kasami codes

```

S1=1 1 1 1 1 1 0 1 0 1 0 1 1 0 0 1 1 0 1 1 1 0 1 1 0 1 0 0 1 0 0 1 1 1 0 0 0 1 0 1 1 1 1 0 0 1 0 1 0 0 0 1 1 0 0 0 0
1 0 0 0 0 0
S2=0 0 0 1 1 0 0 0 1 0 0 1 0 0 1 0 0 0 1 0 1 1 0 0 0 1 1 0 0 1 1 1 1 0 0 1 1 0 0 1 0 1 0 1 1 1 0 0 0 1 1 0 1 0 1 0 1
0 1 0 0 1 0
S3=1 0 0 0 1 1 1 1 1 0 1 1 1 1 0 0 0 1 1 1 0 0 0 0 1 1 0 1 1 1 1 0 1 1 1 0 1 0 1 1 1 0 1 1 1 0 0 1 1 0 1 0 0 0 0 1 0
0 1 1 0 0 1
S4=0 1 0 0 0 1 0 0 0 0 1 0 1 0 1 1 0 1 0 1 1 1 1 0 1 0 0 0 0 0 1 0 0 1 0 1 0 0 1 0 1 1 0 0 1 0 1 1 0 1 0 0 0 1 0 0 1
1 1 1 1 0 0
S5=1 0 1 0 0 0 0 1 1 1 1 0 0 0 0 0 1 1 0 0 1 0 0 1 1 0 1 0 1 1 0 0 0 0 0 0 1 1 1 0 0 1 1 1 0 0 1 0 0 0 1 1 0 1 1 0 0
0 0 1 1 1 0
S6=1 1 0 1 0 0 1 1 0 0 0 0 0 1 0 1 0 0 0 0 0 0 1 0 0 0 1 1 1 0 1 1 0 0 1 0 0 0 0 0 0 1 0 1 1 1 0 1 0 0 0 1 1 1 1 0
1 1 0 1 1 1
S7=0 1 1 0 1 0 1 0 0 1 1 1 0 1 1 1 1 1 1 0 0 1 1 1 1 1 1 1 0 0 0 0 1 0 1 1 0 1 1 1 0 0 0 0 0 0 0 0 1 1 0 1 0 0 1 1 1
1 0 1 0 1 1
S8=0 0 1 1 0 1 1 0 1 1 0 0 1 1 1 0 1 0 0 1 0 1 0 1 0 0 0 1 0 1 0 1 0 1 1 1 1 1 0 0 1 0 0 1 0 1 1 1 1 1 1 1 1 1 0 1 1
0 0 0 1 0 1

```

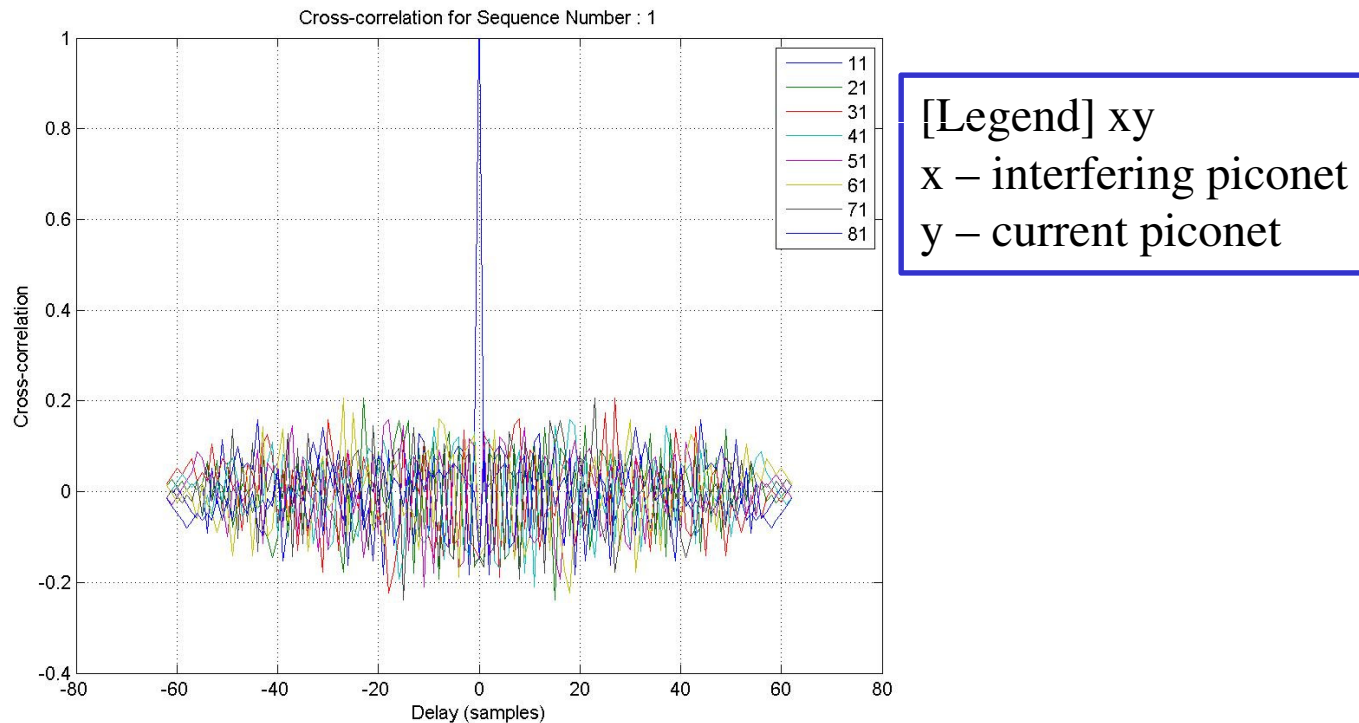

Preamble Design

- Autocorrelation and crosscorrelation characteristics

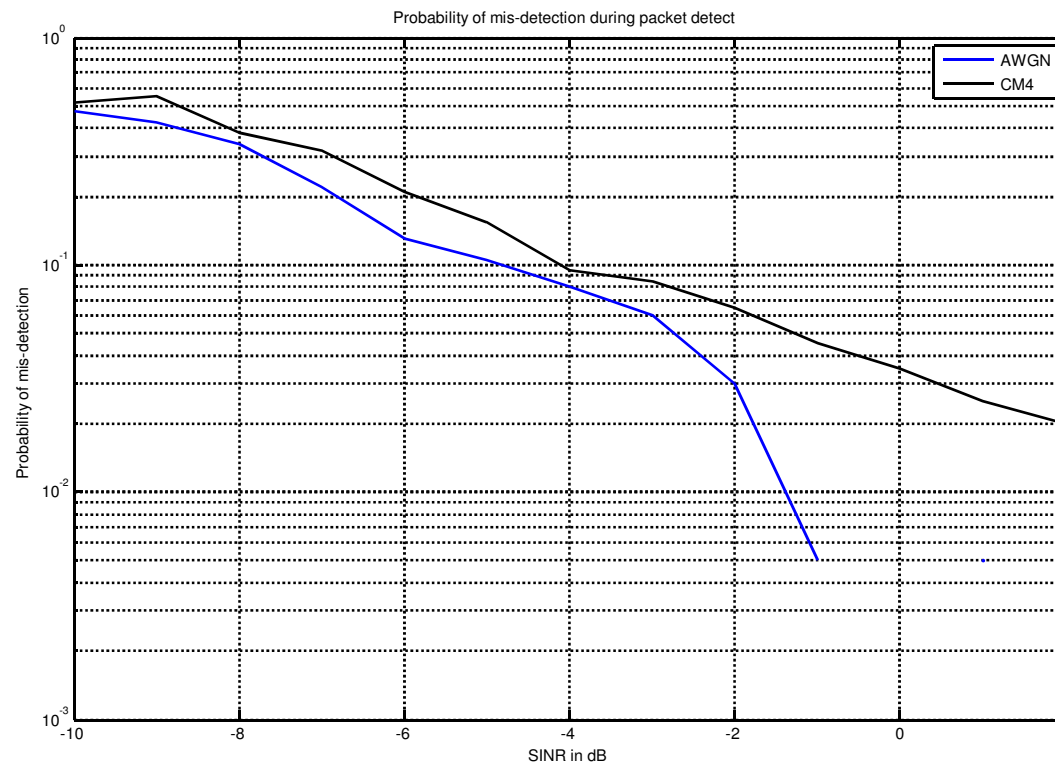

Preamble Performance

- Mis-detection of the preamble for different SINR conditions



Preamble Performance

- Mis-detection of the preamble for different SNR conditions at 0 dB SIR

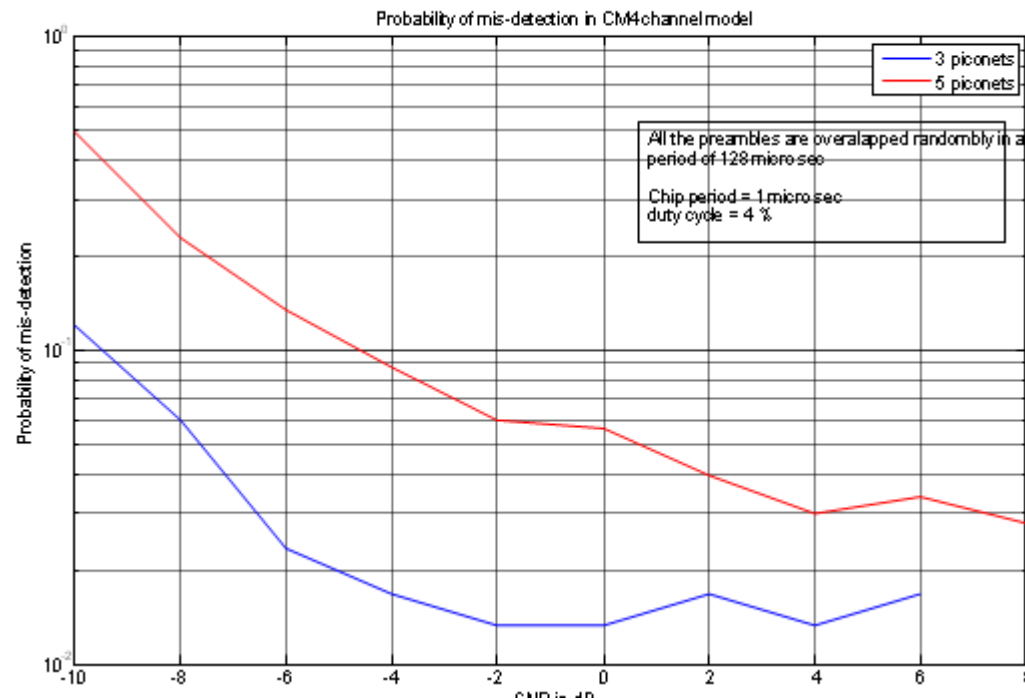

Power Efficiency

- Non-coherent receiver
- Simple pulse design
- Modulation without FEC
- Short Kasami code based preamble

Interference to UWB

Worst Case,
Always
considered in-
band
interference

	Unit	WiMAX	802.11a	ECMA 368	Cordless
Frequency	MHz	3500	5775	7875	5800
Bandwidth	MHz	500	500	500	500
Reference Bandwidth (@UWB)	MHz	10	20	500	6
Tx antenna gain	dBi	-2.0	-2.0	-2.0	-2.0
output power	dBm	17.0	30.0	-14.3	20.0
Average emission PSD	dBm/MHz	-13.7	-0.7	-45.0	-10.7
Rx thermal noise floor	dBm/MHz	-114.0	-114.0	-114.0	-114.0
Rx noise figure	dB	10.0	10.0	10.0	10.0
Rx antenna gain	dBi	-2.0	-2.0	-2.0	-2.0
Operating margin	dB	3.0	3.0	3.0	3.0
Effective operating noise floor	dB	-103.0	-103.0	-103.0	-103.0
Pathloss required	dB	89.3	102.3	58.0	92.3
Minimum distance	m	34.2	66.5	1.8	30.8

Interference from UWB

Worst Case, Always considered in-band interference

	Unit	WiMAX	802.11a	ECMA 368	Cordless
Frequency	MHz	3500	5775	7875	5800
Bandwidth	MHz	10	20	500	6
Reference Bandwidth (@UWB)	MHz	1	1	1	1
output power	dBm/MHz	-41.3	-41.3	-41.3	-41.3
antenna gain	dBi	-2.0	-2.0	-2.0	-2.0
in-band effective output power	dBm	-35.0	-32.0	-18.0	-37.2
Rx thermal noise density	dBm/Hz	-174.0	-174.0	-174.0	-174.0
Rx noise figure	dB	6.0	8.0	6.0	6.0
Rx antenna gain	dBi	-4.0	-4.0	-2.0	-2.0
Noise floor	dBm	-98.0	-93.0	-81.0	-100.0
Allowed interference level	dB	-104.0	-99.0	-87.0	-106.0
Allowed interference level in ref. bandwidth	dBm/MHz	-114.0	-112.0	-114.0	-113.8
Line loss	dB	2.0	2.0	2.0	2.0
Pathloss required	dB	63.0	61.0	65.0	64.8
Minimum distance	m	4.5	2.8	3.1	3.7

Conclusions

- Independent pulse shape architecture
- Data rates scalable from 10 kbps to 10 Mbps
- Low power and low complexity non-coherent transceiver
- Modulation without the use of FEC
- Co-existence of 10 networks possible at 1Mbps

Comparison Criteria

Parameter	Addressed	Comments
Range	Yes	300 m
Power consumption	Yes	Below 25 mW for 1 Mbps
Co-existence of 10 piconets	Yes	16 piconets can co-exist
Scalability	Yes	10 kbps to 8 Mbps
PER of 10 %	Yes	
Link Budget	Yes	
Regulatory	Yes	7.25 to 8.5 GHz

References

- **TG6 Technical Requirements Document**, <https://mentor.ieee.org/802.15/dcn/08/15-08-0644-09-0006-tg6-technical-requirements-document.doc>, IEEE, 2008
- **802.15-08-0780-05-0006-Channel model document of TG6**
- **TG6 Channel model document**, <https://mentor.ieee.org/802.15/file/08/15-08-0780-09-0006-tg6-channel-model.pdf>, IEEE, 2008
- **Amal Ekbal, Jun Shi, Zhanfeng Jia, Jason Ellis, Channel model considerations for IEEE 802.15.6**, <https://mentor.ieee.org/802.15/dcn/08/15-08-0792-00-0006-channel-model-updates-for-802-15-6.ppt>, IEEE 2008
- **“15-09-0141-01-0006-preliminary-wban-proposal-using-ir-uwband-etri.pdf”** Cheolhyo Lee et al.
- **“15-09-0171-04-0006-samsung-preliminary-phy-proposal.ppt”**, Kiran Bynam et al
- Sang-Min Han, Mi-Hyun Son, Yong-Hwan Kim, and Seong-Soo Lee, **“Low-Rate Chaotic UWB Transceiver System Based on IEEE 802.15.4a”**, 36th European Microwave Conference, pp.1837-1840, Sep. 2006
- K. Lee, S. Kyeong, J. Kim, Y. Kim and H. Park, **“The Chaotic On-off Keying with Guard Interval for Ultra-Wideband Communication”**, IEEE VTS Asia Pacific Wireless Communications Symposium, Daejeon, Korea, August 2006
- Sang-Min Han, O. Popov and A.S. Dmitriev, **“Flexible Chaotic UWB Communication System With Adjustable Channel Bandwidth in CMOS Technology”**, IEEE Transactions on Microwave Theory and Techniques, Vol. 56, Issue 10, pp.2229-2236, Oct. 2008