

Project: IEEE P802.15 Working Group for Wireless Personal Area Networks (WPANs)

Submission Title: [Samsung EFC PHY & MAC proposal]

Date Submitted: [4 May, 2009]

Source: [Dr. Jahng Sun Park, Dr. Seong-Jun Song, HyunKuk Choi, Dr. SangYun Hwang, SeokYong Lee, Sung-Min Kim, Chul-Jin Kim, Dr. Noh-Gyoung Kang, Dr. Eun Tae Won]

Re: [Response to IEEE 802.15.6 Call for Proposals]

Abstract: [PHY & MAC proposal for 802.15.6 Requirements.]

Purpose: [To be considered in IEEE 802.15.6]

Notice: This document has been prepared to assist the IEEE P802.15. It is offered as a basis for discussion and is not binding on the contributing individual(s) or organization(s). The material in this document is subject to change in form and content after further study. The contributor(s) reserve(s) the right to add, amend or withdraw material contained herein.

Release: The contributor acknowledges and accepts that this contribution becomes the property of IEEE and may be made publicly available by P802.15.

Contents

- Proposal Scope
- What is EFC?
- PHY
- MAC

Proposal Scope

- Non-Medical applications on the same person
- Data exchange for control, personal health care, entertainment, etc.
 - Periodical data, random bursts, etc.
- Everyday operation environment: home, office, outdoors, etc.
- Up to 8 devices in a piconet: 1 Master and up to 7 slaves
- On-body to On-body (CM3)
 - Devices should be on the body surface or near a person as long as the person can reach and make contact
 - One of the two devices can be up to a few centimeters off the body
- Data rate ranges up to several Mbps
- Low power consumption

Human Body Communication

- Based on Electric-Field Communication (EFC)
 - Data transmitted by inducing electric-field and capacitive coupling on dielectric material
 - Human body has about 300~500 times better permittivity than air
 - No Antenna, less complex
 - Extremely low power consumption

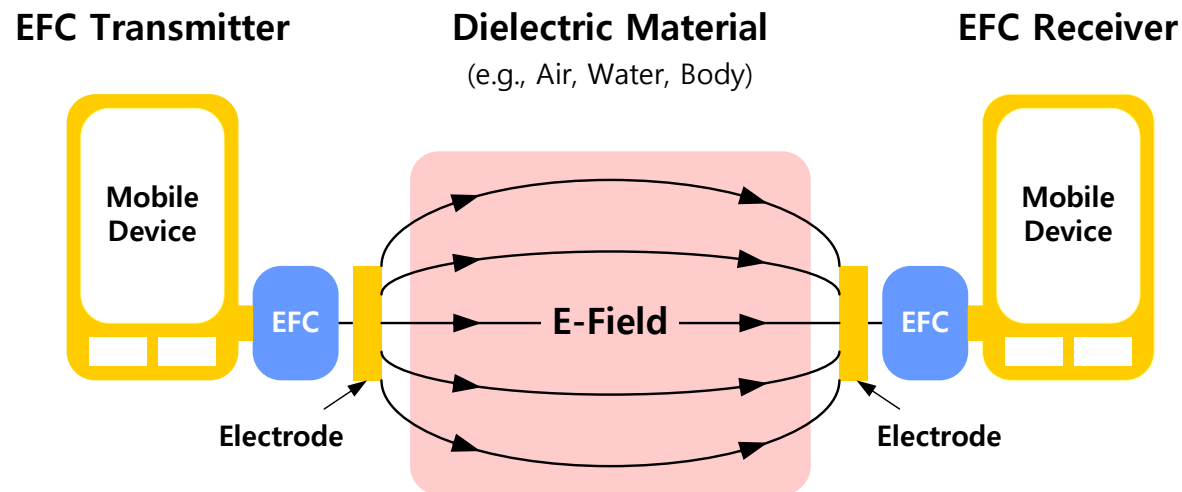

EFC PHY

System Block Diagram

- Modulation
 - Orthogonal modulation using frequency shaping code
- Scalable Data rate
 - Up to several Mbps
- Frequency bands
 - 10 ~ 50 MHz

TRANSMITTER

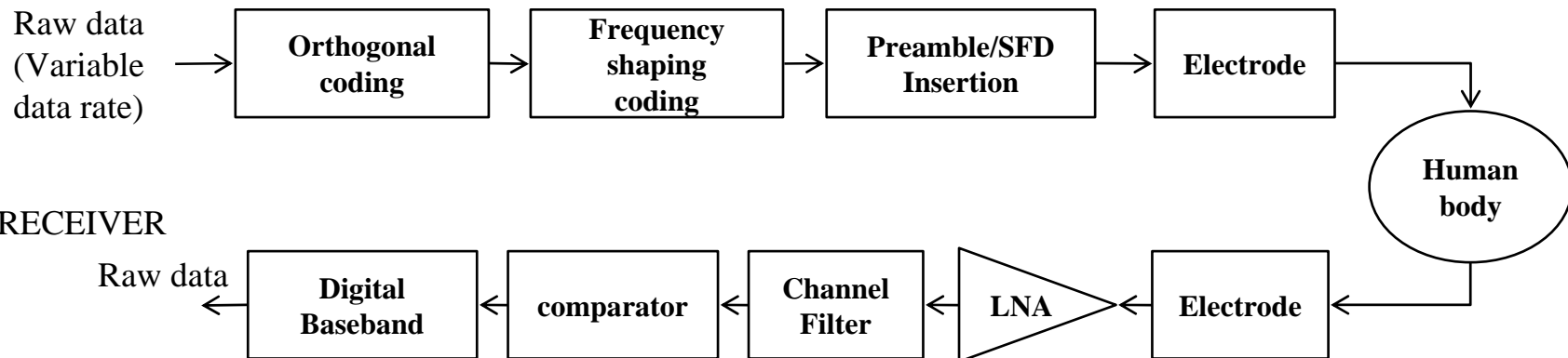

Packet structure

- Consist of preamble(PR), SFD (Start Frame Delimiter), and payload
- In a payload, PHY header, MAC header, Mac payload, and FCS(Frame Check Sequence) are included
- Payload size : < 1 K octets



Signal generation (1/2)

- Preamble
 - Consist of four repeated sequences
 - Use 128-bit gold code for each sequence
- SFD (Start Frame Delimiter)
 - 128-bit gold code
 - Include additional information about data rate by controlling the timing offset of SFD code

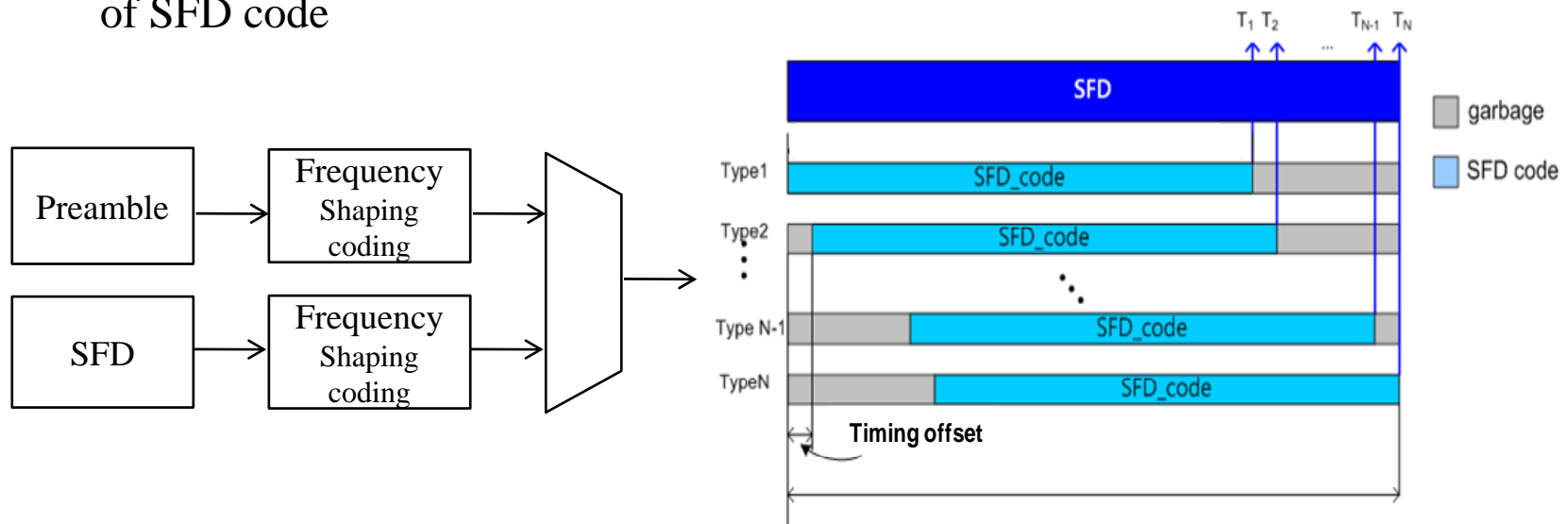

Signal Generation (2/2)

- Payload
 - Modulation scheme : orthogonal coding + frequency shaping coding
 - Signal bandwidth depends on data rate (C), symbol conversion rate ($1/N$), and the length of orthogonal code (2^L)
 - Center frequencies are determined by frequency shaping coding operation

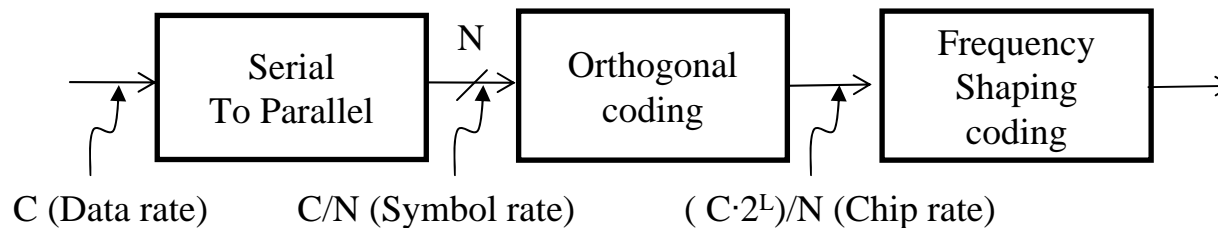

Receiver Structure

- Use of a single electrode instead of 50Ω antenna
- No need for the blocks related to RF carrier signals such as mixer or PLL
- Continuous wave processing in the analog front-end
- 1-bit energy detection in the digital baseband

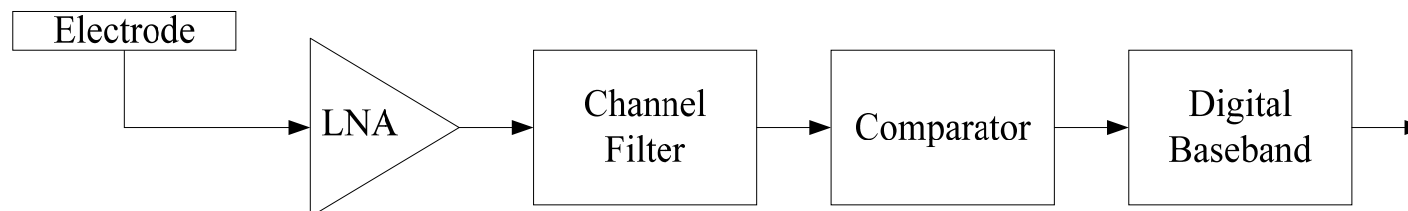

Simulated AWGN Performance

- AWGN channel
- Simulated in MATLAB in case of two samples per chip
- Symbol sync. & frame sync. operations are considered
- 1-K octets payload

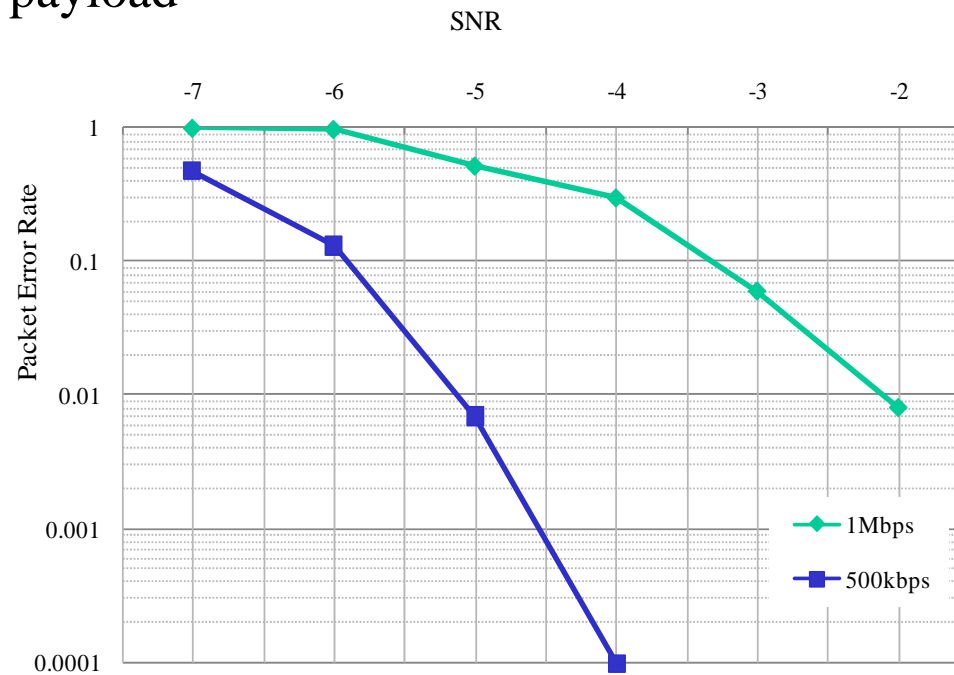

Link Budget

Parameter	Symbol	Value	Unit
Data Rate	R	1	Mb/s
Average Tx Power ⁽¹⁾	P_{TX}	7	dBm
Path Loss	P_L	101	dB
Average Rx Power ($P_{RX}=P_{TX}-P_L$)	P_{RX}	-94	dBm
Rx Noise Figure	NF	3	dB
Average Noise Power per bit ($P_N=-174+10\log_{10}(R)+NF$)	P_N	-111	dBm
Minimum required E_b/N_o for BER= 10^{-6}	$E_b/N_o _{req}$	4	dB
Implementation Loss	I_L	3	dB
Link Margin ($LM=P_{RX}-P_N-E_b/N_o _{req}-I_L$)	LM	10	dB
Minimum Rx Sensitivity Level ($S_{RX}=P_{RX}-LM$)	S_{RX}	-104	dBm

(1) Voltage-mode transmission @ 50Ω load

Low Power Architecture

- Transmitter
 - Implemented with only digital circuits and share one electrode with receiver
- Receiver
 - No need for the blocks related to RF carrier signals such as mixer or PLL
 - Use a comparator instead of multi-bit ADCs
- MAC protocol
 - Slotted frame structure (allow variable power management schemes)

EFC MAC

EFC-Frame Structure (1/2)

- Slotted frame structure for multiple-node BAN
 - Time slotted method for up to 7 slave nodes (and 1 master node) per BAN
 - Downlink/Uplink slots based on TDD method
- Broadcast frame (every EFC-frame)
 - Contains information about each EFC-frame
 - # of Frame, Inactive Period, Frame Index, Slave Node ID, DL/UL ratio
 - Slots for join request

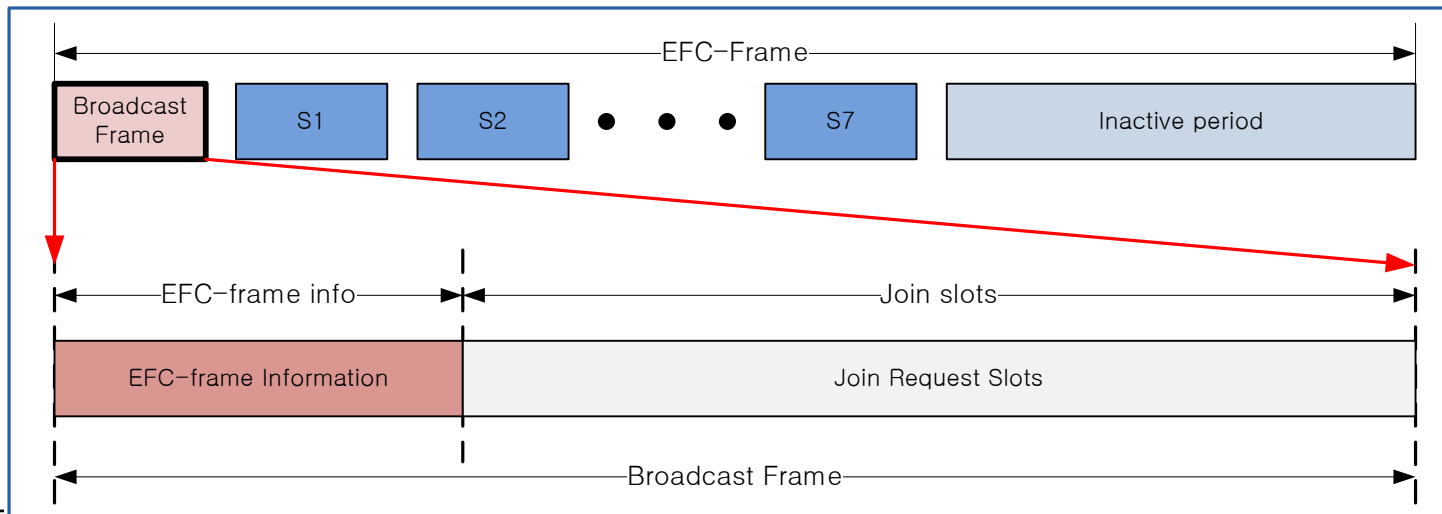

EFC-Frame Structure (2/2)

- Frame's Downlink/Uplink ratio (10:0, 9:1, 8:2, ... , 0:10) and slot structure

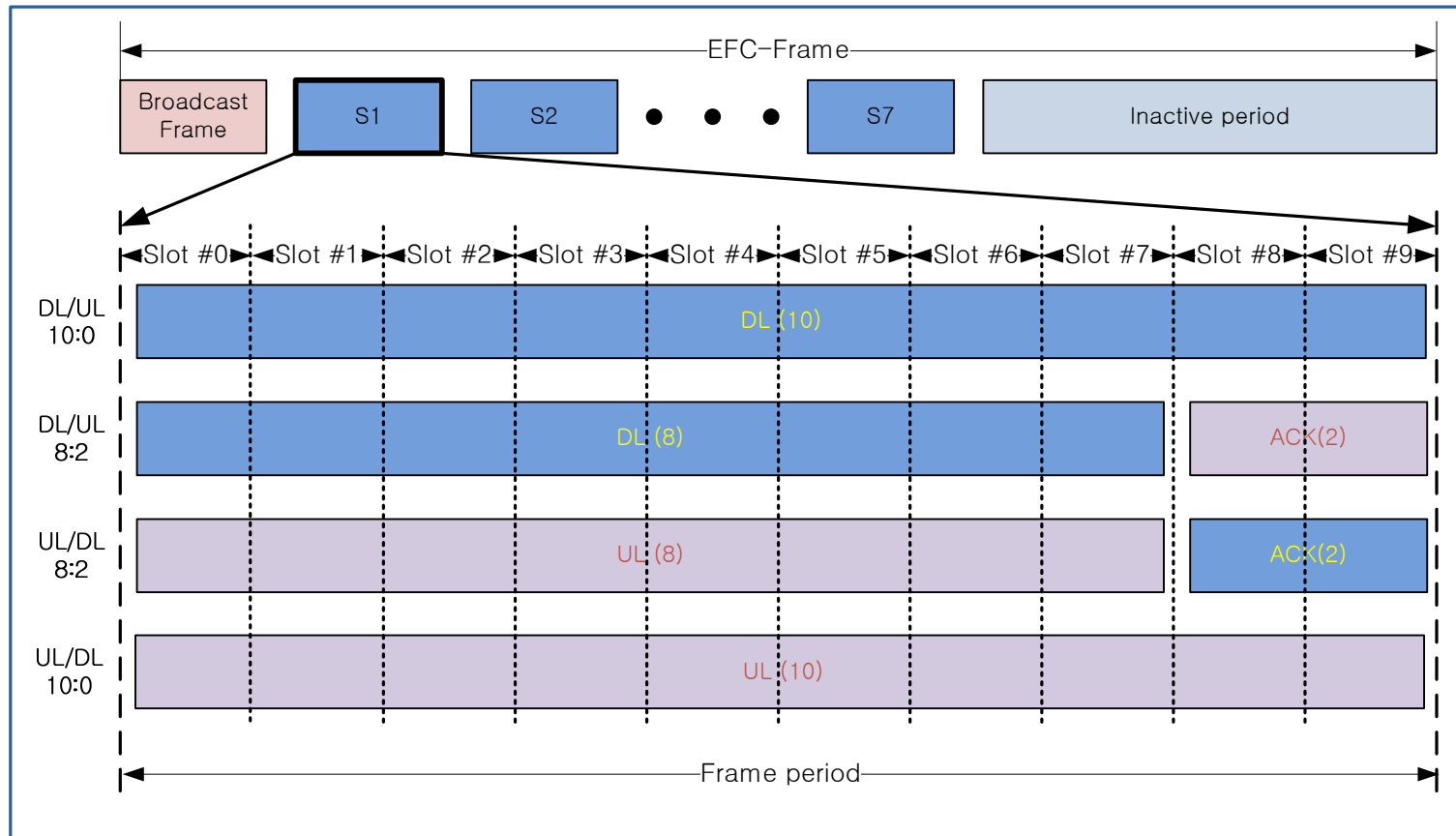

PHY Header

- Frame ID: Indicates that this is the n -th frame of this EFC-frame
- Sync: Used to synchronize slot boundary at Rx side
- D: '1' → Dedicated Mode
- PSDU Length: Indicates the length of PSDU (up to 4KB)
- CRC8: CRC information of the PHY header

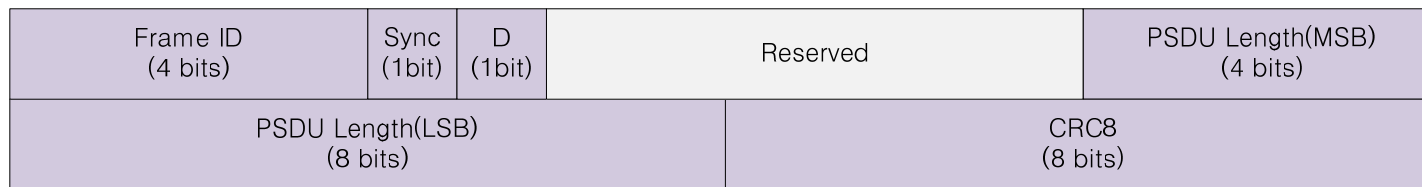

MAC Header (1/2)

Frame Type (3 bits)	BID (5 bits)	ACK (1bit)	DL/UL Ratio (5 bits)	AM (2 bits)
Frame Sequence Number (8 bits)		SEC (2 bits)	Reserved	
SID (4 bits or 64 bits)		SID (4 bits or 64 bits)		
SID (4 bits or 64 bits)		SID (4 bits or 64 bits)		
SID (4 bits or 64 bits)		SID (4 bits or 64 bits)		
SID (4 bits or 64 bits)		SID (4 bits or 64 bits)		
RID (4 bits or 64 bits)		RID (4 bits or 64 bits)		
RID (4 bits or 64 bits)		RID (4 bits or 64 bits)		
RID (4 bits or 64 bits)		RID (4 bits or 64 bits)		
RID (4 bits or 64 bits)		RID (4 bits or 64 bits)		
MSDU Length(MSB) (8 bits)		MSDU Length(LSB) (8 bits)		

MAC Header (2/2)

- Frame Type: MAC frame type
- BID: BAN Identification number
- ACK: '1' → ACK required Tx Frame
- DL/UL Ratio: Current frame's Downlink/Uplink ratio
- SEC: Applied Security Mode
- Frame Sequence Number : Distinguished each frame
- AM: Address mode
- SID: Source address (4-bit NWK or 64-bit Extended)
- RID: Receiver address (4-bit NWK or 64-bit Extended)
 - If 4-bit NWK address is used [SID|RID] forms 1byte
- MSDU Length: Payload length

Frame Type	
000	Broadcast
001	ACK
010	Data
011	Control
100	Join Request
101 ~ 111	Reserved

Address Mode	
00	Tx_NWK/ Rx_NWK
01	Tx_NWK / Rx_EXT
10	Tx_EXT / Rx_NWK
11	Tx_EXT / Rx_EXT

Example Scenarios (1/4)

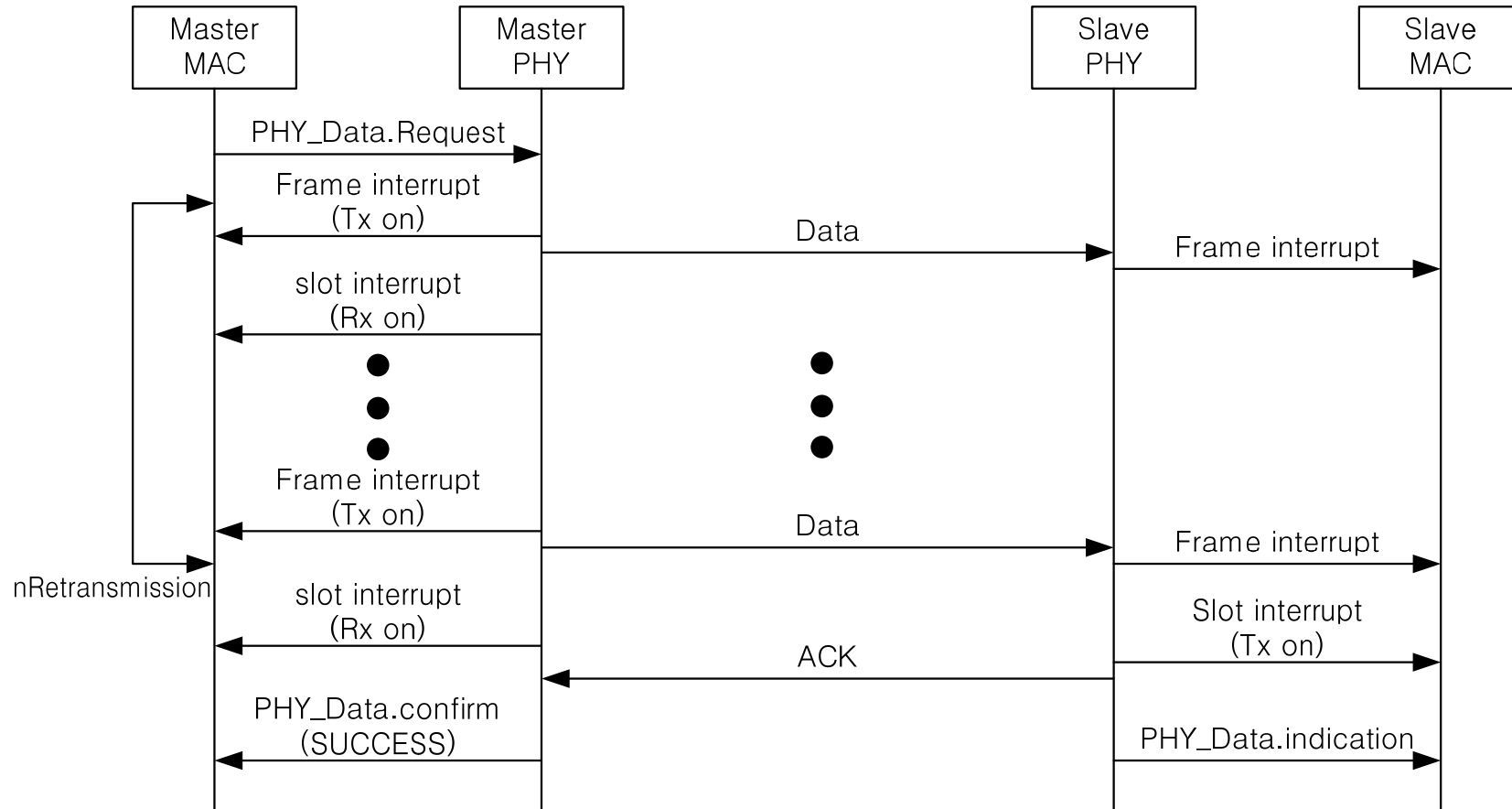

Data Transmission with acknowledgement (downlink)

Example Scenarios (2/4)

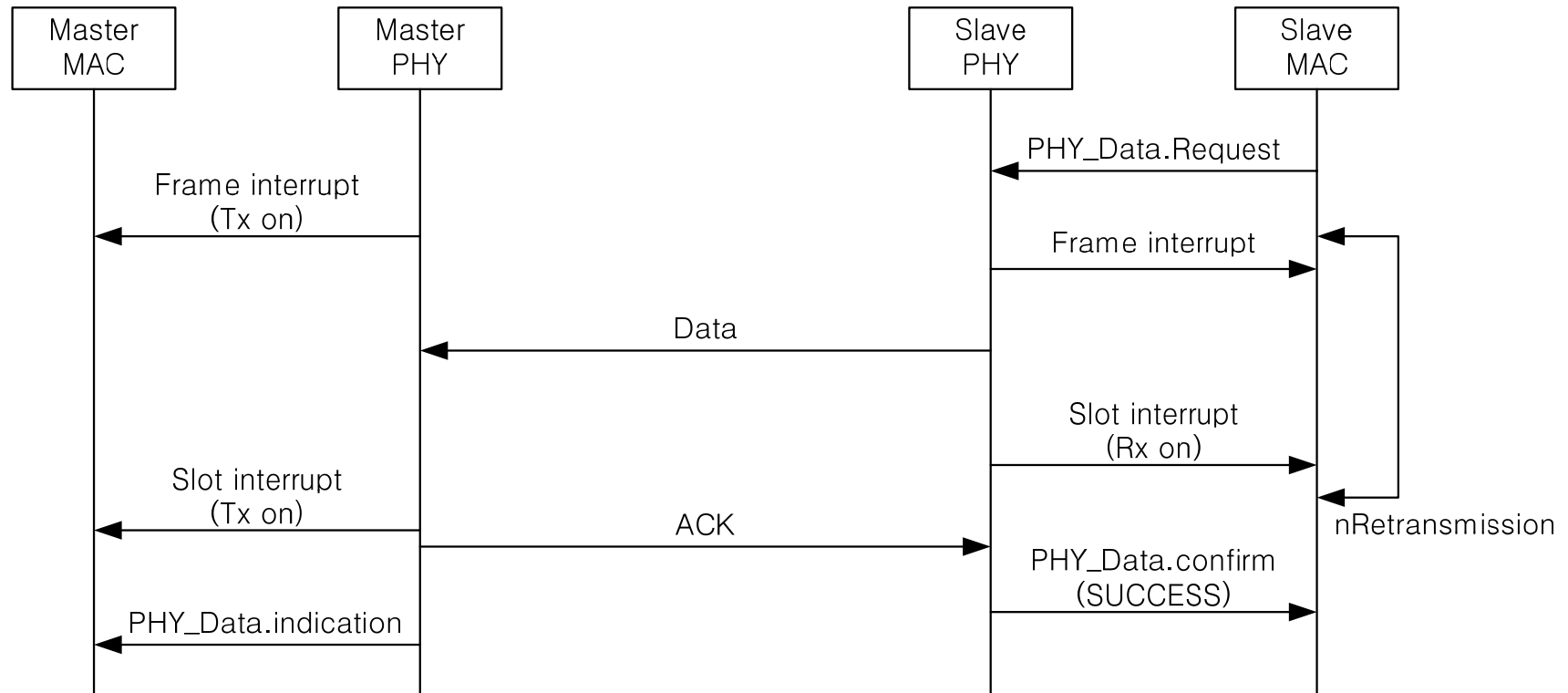

Data Transmission with acknowledgement (uplink)

Example Scenarios (3/4)

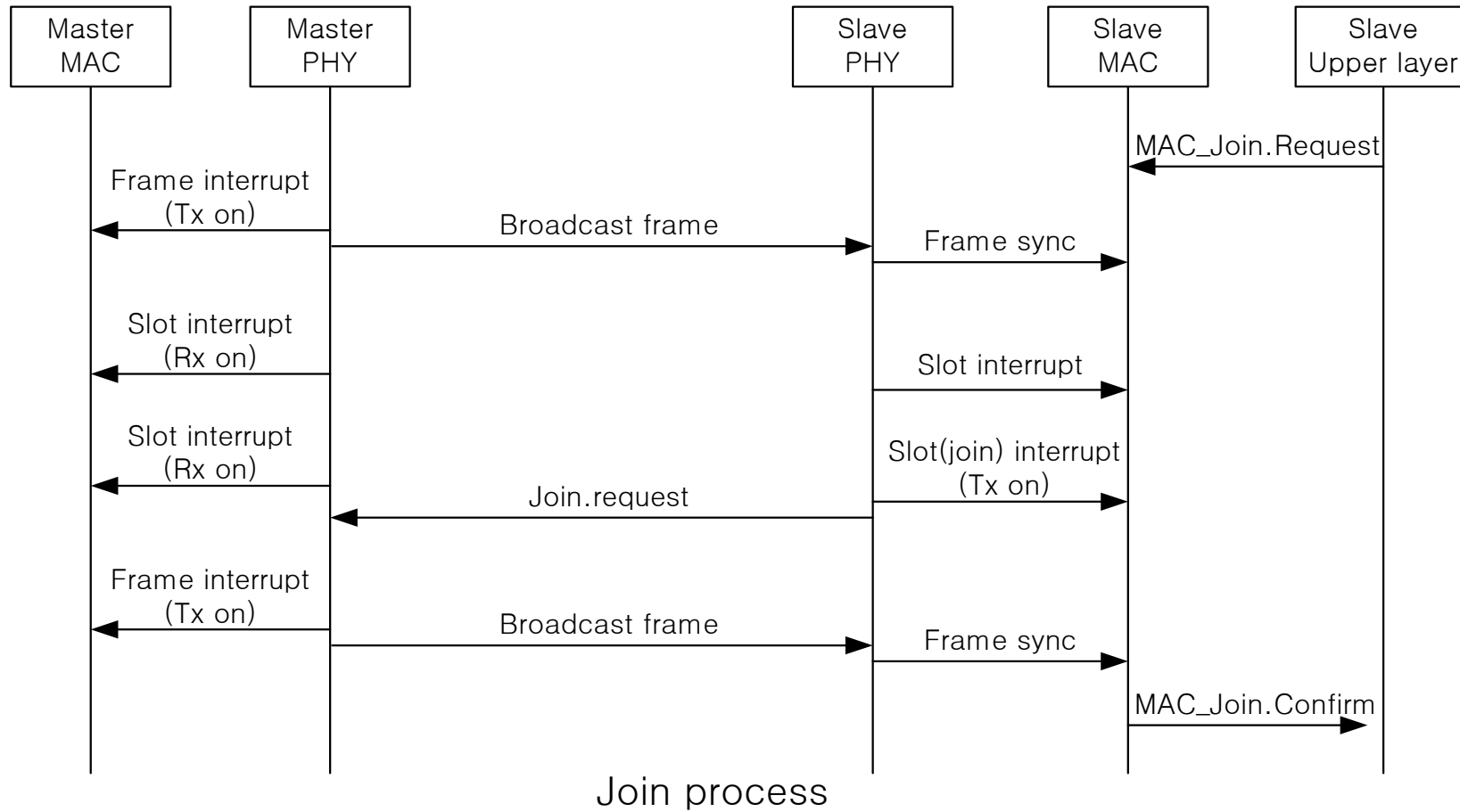

Example Scenarios (4/4)

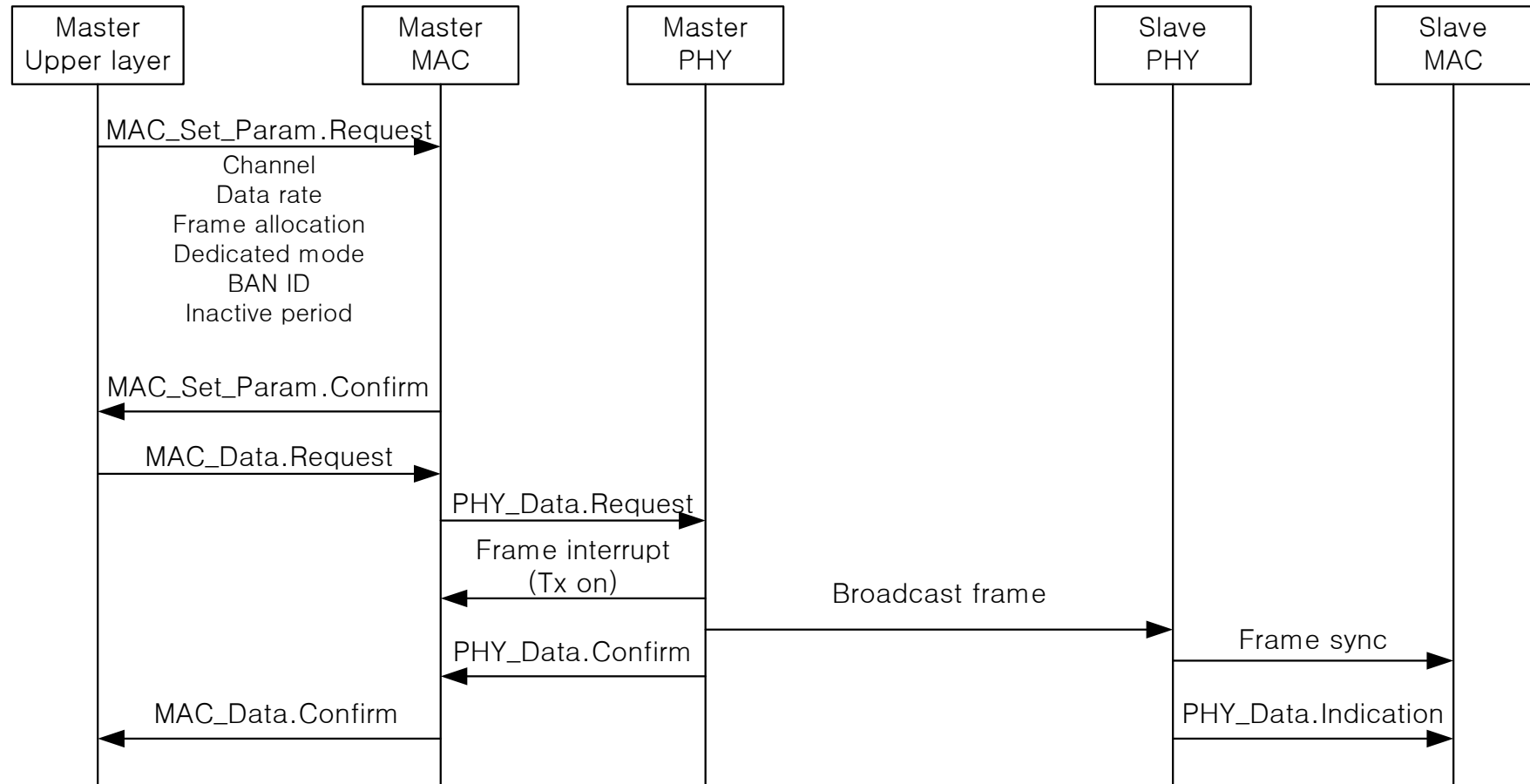

BAN Start Process

MAC-Layer Security Mode

- Security Mode 1: Unprotected (no security)
 - No encryption or authentication is used

- Security Mode 2: Authentication Only
 - No encryption is used

- Security Mode 3: Encryption Only
 - No authentication; AES-128 encryption only

- Security Mode 4: Encryption & Authentication