

## **Project: IEEE P802.15 Working Group for Wireless Personal Area Networks (WPANs)**

**Submission Title:** [Partial PHY/MAC Proposal for IEEE802.15.6]

**Date Submitted:** [4 May, 2009]

**Source:** [Hind Munzer-Chebbo **and** Saied Abedi],[Ichirou Ida **and** Kaoru Yokoo]

Company: [Fujitsu Laboratories of Europe Limited **and** Fujitsu Laboratories of Europe Limited]

Address: [Hayes Park Central, Hayes End Road, Hayes, Middlesex, UB4 8FE, U.K] **and** [Fujitsu Laboratories Limited, YRP R&D Center, 5-5, Hikari-no-Oka, Yokosuka-Shi, Kanagawa 239-0847, Japan]

E-Mail: [Hind.Chebbo@uk.fujitsu.com **and** Saied.Abedi@uk.fujitsu.com]

[ida.ichirou @jp.fujitsu.com **and** yokoo@labs.fujitsu.com]

**Re:** [Proposal to IEEE802.15.6.]

**Abstract:** [Proposal for partial Physical (PHY) and Media Access Control (MAC) layers and for the management of emergency scenarios in IEEE802.15.6 Body Area Networks (BANs). The proposed solutions apply to both medical BANs (MBAN) and non-medical BANs.]

**Purpose:** [This proposal consists of a set of ideas to be included in the PHY and MAC layers of the IEEE802.15.6 specification. The partial PHY proposal consists of ideas for narrowband radio, while the partial MAC proposal consists of ideas for the management of both medical and non-medical emergency situations in BANs. The proposed MAC Frame Control format, with new information bits and octets, should be considered in the design of the MAC layer for IEEE802.15.6.] .]

**Notice:** This document has been prepared to assist the IEEE P802.15. It is offered as a basis for discussion and is not binding on the contributing individual(s) or organization(s). The material in this document is subject to change in form and content after further study. The contributor(s) reserve(s) the right to add, amend or withdraw material contained herein.

**Release:** The contributor acknowledges and accepts that this contribution becomes the property of IEEE and may be made publicly available by P802.15.

# Partial PHY/ MAC Proposal for IEEE802.15.6

Hind Munzer-Chebbo, Saied Abedi,  
Ichirou Ida **and** Kaoru Yokoo

Fujitsu

# Contents

- TG6 Requirements Targeted
- PHY elements for IEEE802.15.6
- MAC elements for IEEE802.15.6
  - Proposed MAC frame structure
    - MAC commands
    - Frame types
- Potential protocol
  - Congestion control
  - Stability Management
  - Handover procedure
  - On-demand data streaming scheduling
  - Emergency induced switching between different beacon and non-beacon modes
  - Adaptive duty cycling
- Summary

## TG6 Requirements Targeted

- Section 8 of the Technical Requirements, 15-08-0644-09-0006-tg6, mandates Emergency Management capabilities for the IEEE802.15.6 specification.
  - **Emergency Management**
    - MUST support alarm state notification across BAN in less than 1 second
    - MUST provide prioritisation mechanisms for emergency traffic and notification
  - **Power management**
    - Should provide a mechanism to lower the priority of or cancel power management in emergencies.
    - Power management (e.g. using duty cycling) should be provided whilst not impacting latency requirements.

# PHY elements for IEEE802.15.6

## PHY elements for IEEE802.15.6

- Motivation
- Proposal
  - Sleep and wake-up mode
    - Explanation of wake-up mode
    - PHY design for the mode
  - Signal probing mode
    - Mechanism of signal probing
    - PHY design for probing
- Conclusions

## Motivation

1. Battery life is crucial property for many BAN devices specially for implant devices.
  - Efficient “sleep” and “wake-up” scheme should be implemented.
    - *RFID tags operating by “Semi-passive mode” has very long battery life because of very low- power wait circuitry without oscillators.*
2. Shadowing caused by change of the posture (e.g. sitting, standing or lying) may damage communication seriously, and it can last for a long time.
  - Spontaneous probing of the channel from the receiving node while changing the antenna configuration might avoid it.

## Proposal

1. Sleep and Wake-up mode employing dual-PHY for Narrow band (**for Energy Saving**)
  - ASK(OOK) for Sleep/Wake-up mechanism
    - For ultra-low power sleep mode by circuitry without oscillator.
    - For very low rate communication (interrogation) under sleep-mode.
  - Gaussian filtered FSK (GFSK) for Normal communication
    - For normal mode in narrow band
    - Power effective non-linear power amplification
2. Channel probing mode to mitigate the shadowing effect (**for Stable communication**)
  - Series of channel probing packet transmission at each antenna configuration when a bad communication status is detected.



## PHY elements for IEEE802.15.6

- Motivation
- Proposal
  - Sleep and wake-up mode
    - Explanation of wake-up mode
    - PHY design for the mode
  - Signal probing mode
    - Mechanism of signal probing
    - PHY design for probing
- Conclusions

## Sleep and Wake-up mode

- Sleep state
  - All circuitry except Wake-up circuit is powered off
  - Wake-up circuit is waiting for wake-up packet, which is OOK based PHY, under ultra low power consumption
    - Optionally, wake-up circuit can be battery-free radio like RFID tag operated by energy generated from wake -up packet.
- Wake-up procedure
  - Wake-up circuit trig the Main circuit according to the “wake-up command” in the wake-up packet.

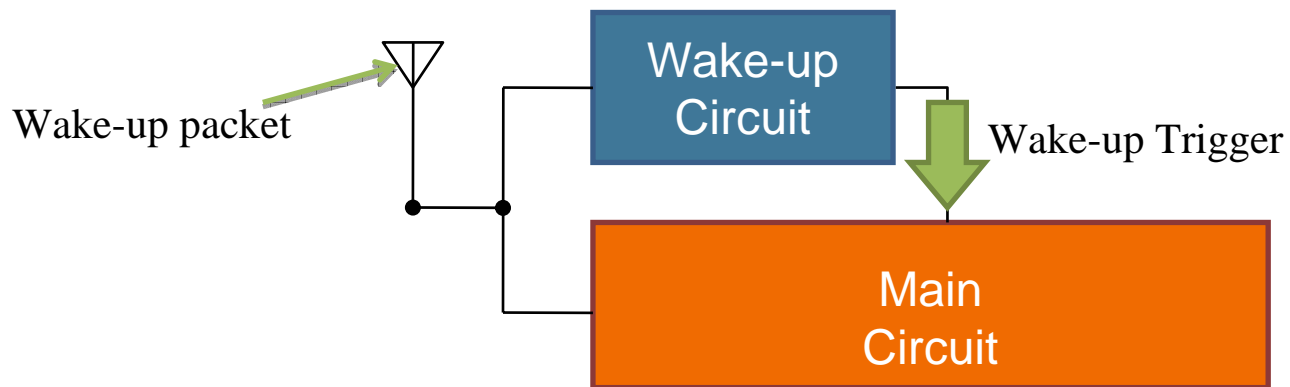

## Additional function for Sleep mode

- “Interrogation and response” procedure in sleep-mode for very short messages (e.g. identification, battery life or state of circuitry )
  - Wake-up circuit responds to interrogation at very low data rate. (10kbps )
  - Some commands are interpreted by wake-up circuit like RFID system
    - “Read <address>”: read an indicated address of internal memory and send back
      - E.g. Sensor log, battery level, history of sensing, and so on...
    - “Wake-up” : wake up main circuitry
    - Other command: other preferred commands

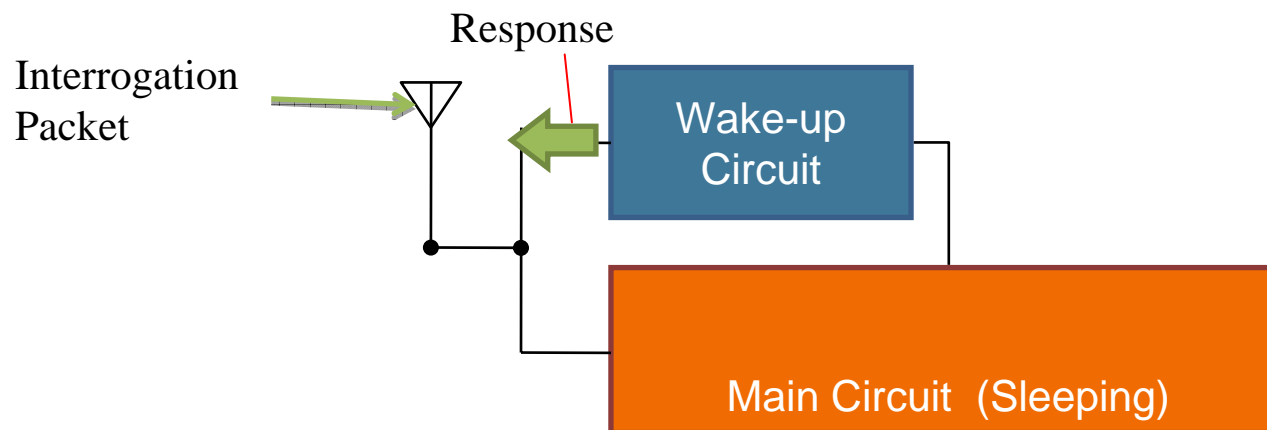

# Examples of the sequence

- Block diagram of Wake-up

- Wake-up PHY communication (dashed blue arrow)
- Normal PHY communication (solid red arrow)

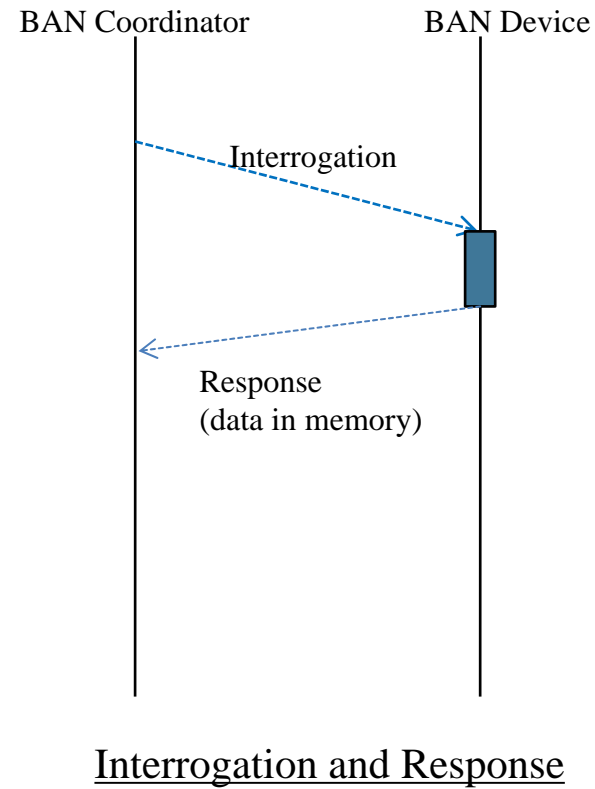
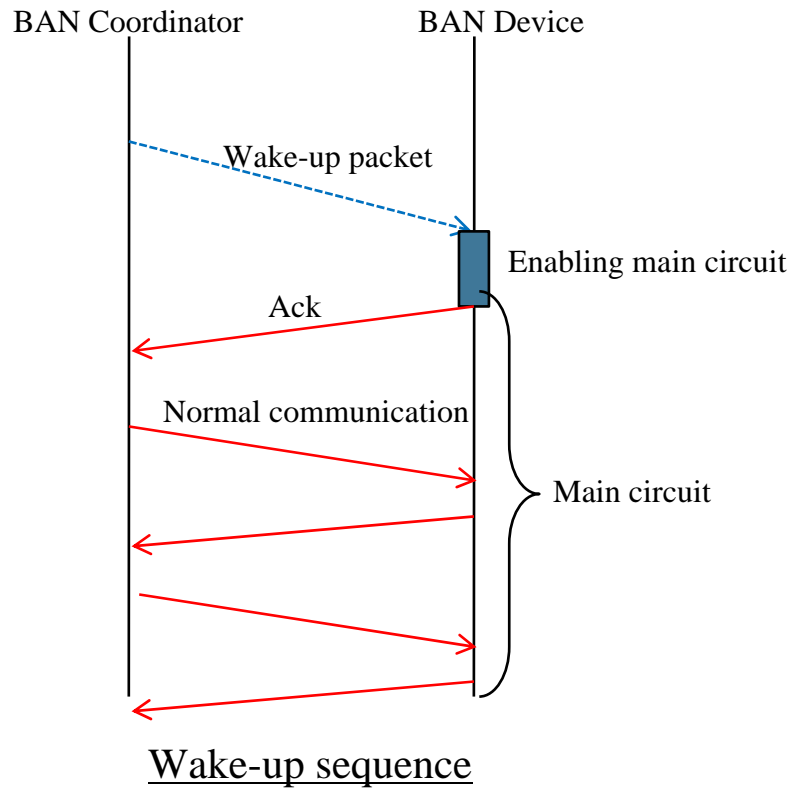

## OOK / FSK

- OOK for Sleep/Wake-up PHY
  - Easy to implement
  - Possible to implement without oscillators like RFID tags.
  - Modulated backscattering method is applicable
- GFSK for General PHY
  - Non-linear amplification can achieve effective transmission.
  - Non-coherent detection is possible

# Power Spectra

## OOK

Twice of symbol rate is enough as occupied bandwidth for RRC filtered OOK

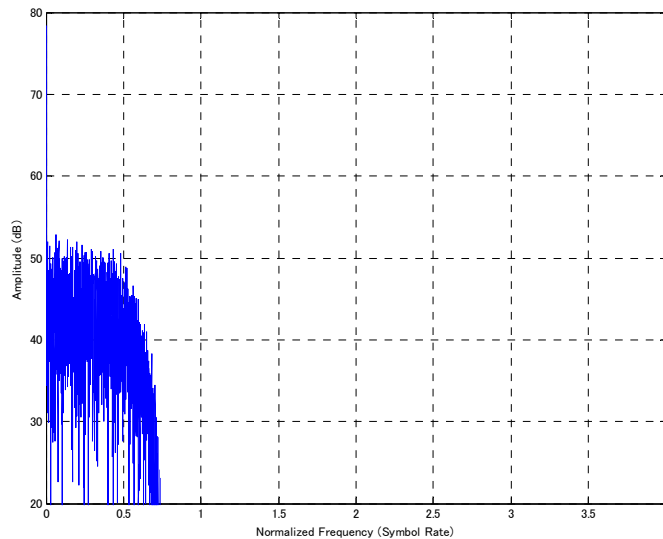

RRC filtered OOK ( $m=1, \alpha=0.5$ )

## FSK

4 times of symbol rate seems to be necessary as occupied bandwidth for both RRC and Gaussian filtered FSK

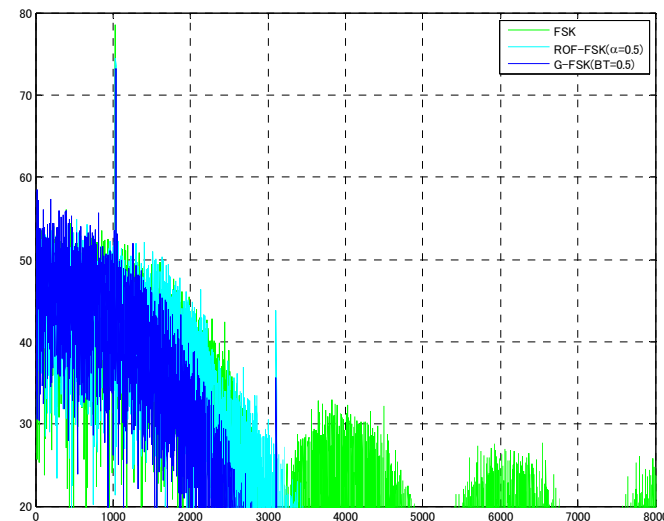

FSK ( $m=1$ )

## Data rate and modulation

- OOK
  - 10kbps for “wake-up” packets is Mandatory
  - Other rates are optional
- FSK
  - 640kbps is optional

Modulation	FEC	Data Rate	Occupied Bandwidth	Applicable Bands
FSK	None	40kbps 160kbps 320kbps 640kbps	40kHz 80kHz 1.28MHz 2.56MHz	MICS, WMTS,ISM,
OOK	None	10kbps(Mandatory) 20kbps 40kbps	20kHz 40kHz 80kHz	MICS, WMTS,ISM,

# BER/PER Performance

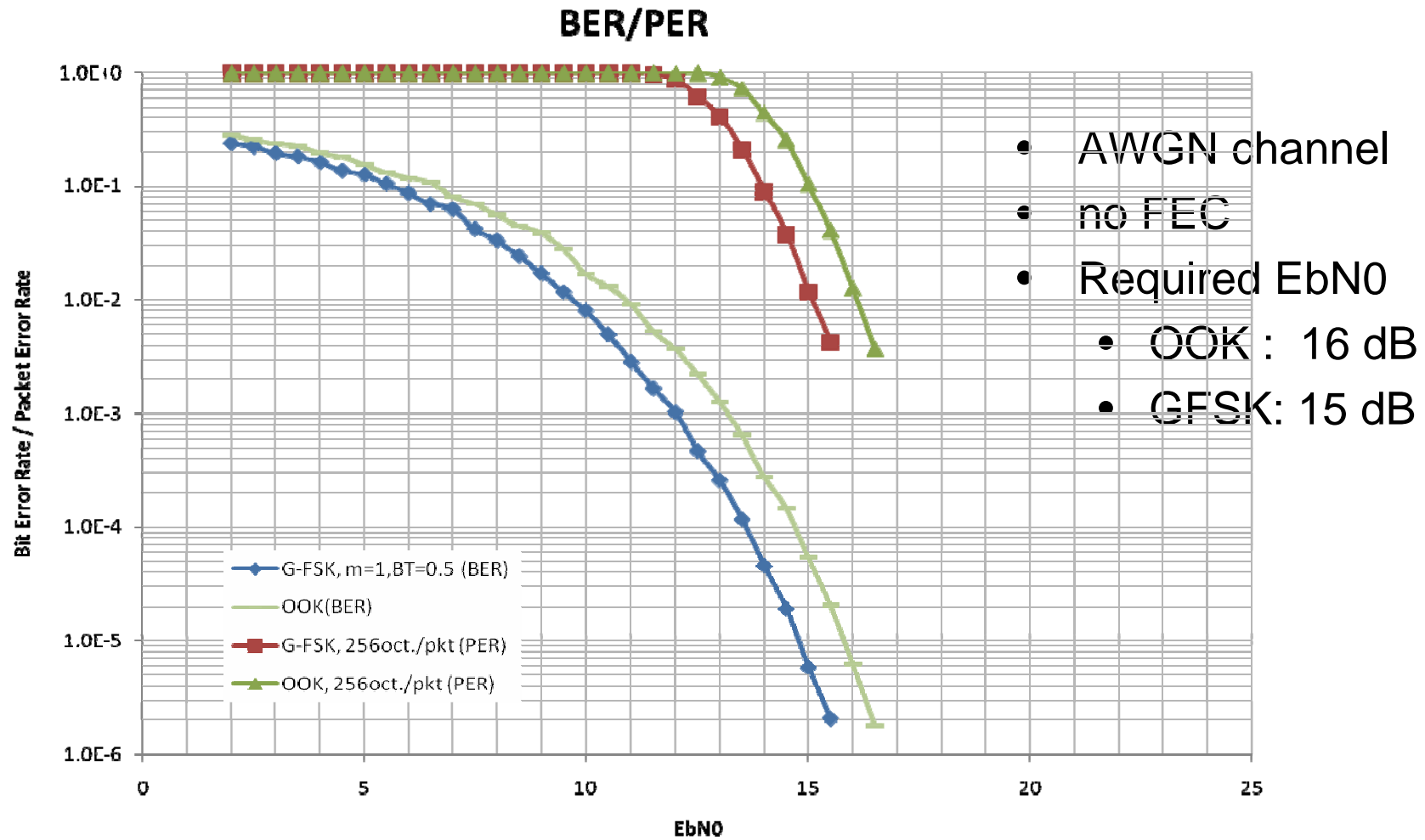



## Linkbudget

- The path loss in the budget is based on the channel model document(P802.15-'08/780r5)
- 90% path loss value in CDF of path loss which have log-normal distribution. (see P802.15-09/160r0)

## PHY elements for IEEE802.15.6

- Motivation
- Proposal
  - Sleep and wake-up mode
    - Explanation of wake-up mode
    - PHY design for the mode
  - Signal probing mode
    - Mechanism of signal probing
    - PHY design for probing
- Conclusions

## Channel Probing

- Measuring the channel status by sending  $N$  probe packets **from the receiving node**.
  - The quality of the channel is determined by the packet success rate  $R$  that is the ratio of the returned ACK from the sending node to the number of the initially sent probe packets  $N$ .
  - When  $R > R_{th}$  change the antenna configuration and measure channel condition using probing packets. Repeat the process for each antenna configuration until the packet success rate becomes  $R > R_{th}$  or select the antenna configuration with lowest  $R$ .

# Mechanism of Channel Probing

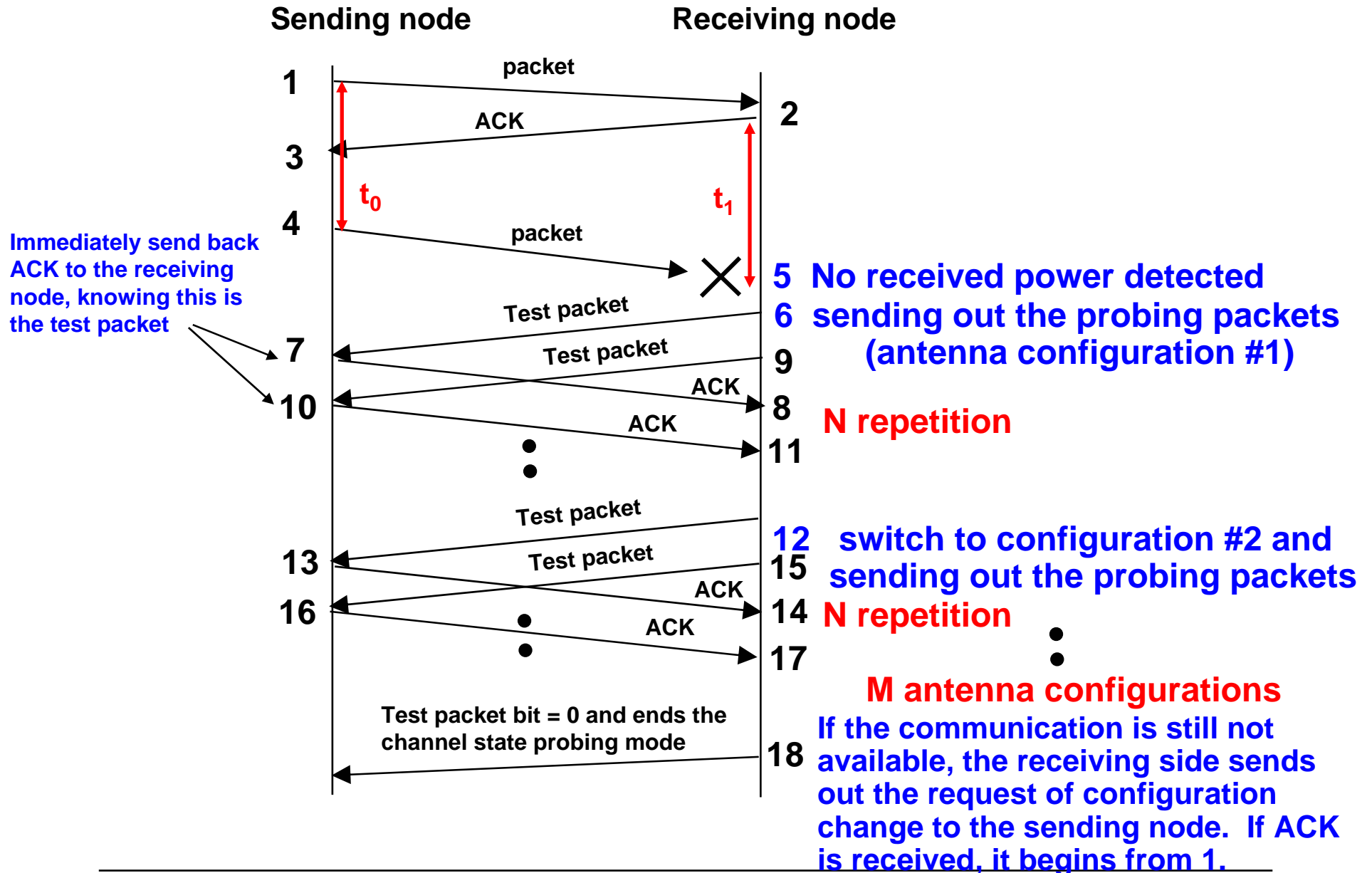

# Antenna configuration examples

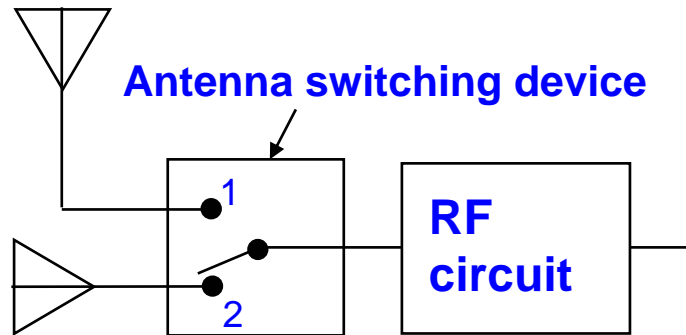

Config. No.	Switch port
1	1
2	2

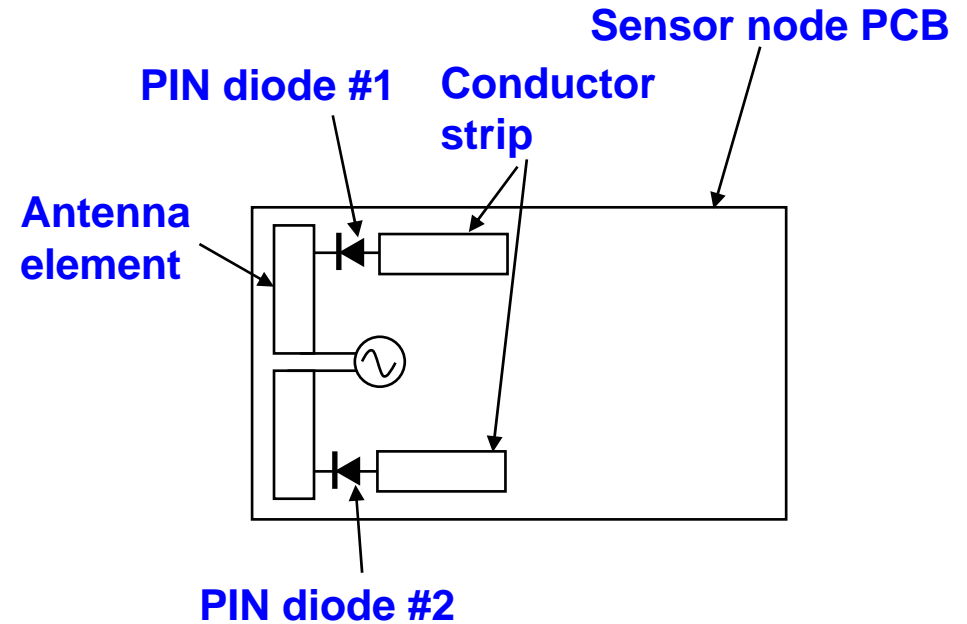

Config. No.	PIN diode #1	PIN diode #2
1	OFF	OFF
2	OFF	ON
3	ON	OFF
4	ON	ON

# PHY elements for IEEE802.15.6

## Conclusions

1. Sleep and Wake-up mode employing dual-PHY for Narrow band (for Energy Saving)
  - ✓ For very low rate communication (interrogation) under sleep-mode
2. Channel probing mode to mitigate the shadowing effect (for Stable communication)
  - ✓ Series of channel probing packet transmission at each antenna configuration when the communication is deteriorated by shadowing effect.

# MAC elements for IEEE802.15.6

## MAC elements for IEEE802.15.6

- Motivation
- IEEE802.15.4 frame format
- IEEE802.15.6 Proposal
- Potential Protocols for Exploitation of Proposed MAC frame



## Motivation

- To prolong battery life of wireless BAN devices / sensors without compromising latency and QoS of BAN applications (Medical and Non-Medical).
- To enable provisioning of medical applications using wireless BAN

# IEEE802.15.4 MAC Frame Structure



1 MAC Frame

Octets: 2	1	0/2	0/2/8	0/2	0/2/8	0/5/6/10/14	variable	2
Frame Control	Sequence Number	Destination PAN Identifier	Destination Address	Source PAN Identifier	Source Address	Auxiliary Security Header	Frame Payload	FCS
		Addressing fields						
MHR							MAC Payload	MFR

Frame Control

Bits: b0–b2	b3	b4	b5	b6	b7–b9	b10–b11	b12–b13	b14–b15
Frame Type	Security Enabled	Frame Pending	ACK Request	PAN ID Compression	Reserved	Dest. Addressing Mode	Frame Version	Source Addressing Mode

Frame Type

Frame Type Value b <sub>2</sub> b <sub>1</sub> b <sub>0</sub>	Description
000	Beacon
001	Data
010	ACK
011	MAC Command
100	Reserved
101	Reserved
110	Reserved
111	Reserved

## IEEE802.15.4 MAC Commands

- Carried in the MAC Payload part of the MAC Frame

Command Frame Identifier	Command Name	RFD		FFD	
		Tx	Rx	Tx	Rx
0x01	Association Request	X		X	X
0x02	Association Response		X	X	X
0x03	Disassociation Notification	X	X	X	X
0x04	Data Request	X		X	X
0x05	PAN ID Conflict Notification	X		X	X
0x06	Orphan Notification	X		X	X
0x07	Beacon Request			X	X
0x08	Coordinator Realignment		X	X	X
0x09	GTS Request			X	X
0x0a-0xff	Reserved				

RFD = Reduced Function Device

FFD = Full Function Device

# MAC Frame Structure Proposal for IEEE802.15.6

# Proposed Frame Structure for IEEE802.15.6

Based on IEEE802.15.4 with following New Elements:

- Device State Field → To support Emergency States & Battery State Signalling
- ACK Policy Field → To support fast Ack for Emergency Conditions
- Stream Index Field → For prioritisation

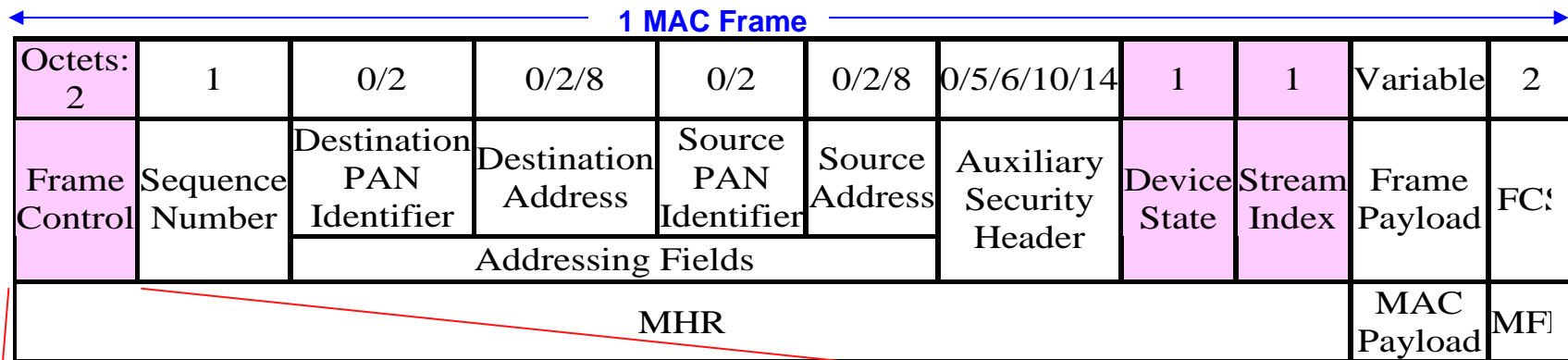

MAC Frame Control Field

Bits: b0–b2	b3	b4	b5–b6	b7	b8	b9	b10–b11	b12-b13	b14–b15
Frame Type	Security Enabled	Frame Pending	Ack. Policy	PAN ID Compression	Device State Flag	Reserved	Destination Addressing Mode	Frame Version	Source Addressing Mode

**Start with IEEE802.15.4 MAC Frame Structure**

**Add** in a *Device State* octet (see slide 7)

**Add** in a *Stream Index* octet (see slide 6)

**Specify additional flags for:** ACK Policy (see Slide 11), Device State (see Slide 7)

## IEEE802.15.6 MAC Command Frame Format

Octets: 2	1	0/2 + 0/2/8 + 0/2 + 0/2/8	0/5/6/10/14	1	1	1	Variable	2
Frame Control	Sequence Number	Addressing Fields	Auxiliary Security Header	Device State	Stream Index	MAC Command ID	MAC Command Payload	FCS
MHR						MAC Payload		MFR

- As in IEEE802.15.4, MAC commands are in the MAC Payload
- A MAC command is a **combination of a MAC command ID and a MAC command payload**, which adds context to the command

# Proposed MAC Commands for IEEE802.15.6

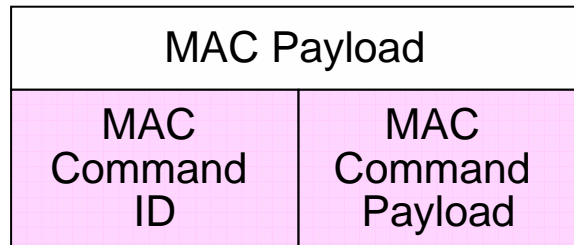

1 Byte

Variable Length

Command Frame Identifier	Command Name	RFD	
		Tx	Rx
0x01	Association Request	X	
0x02	Association Response		X
0x03	Disassociation Notification	X	X
0x04	Data Request	X	
0x05	PAN ID Conflict Notification	X	
0x06	Orphan Notification	X	
0x07	Beacon Request		
0x08	Coordinator Realignment		X
0x09	GTS Request		X
0x0a	Device State Request		X
0x0b	Emergency Notification	X	X
0x0c	Handover		X
0x0d	Stability Notification	X	X
0x0e	Test Packet	X	X
0x0f	Antenna Change Request	X	X
0x10	Stream Request	X	X
0x11	Stream Response	X	X
0x12-0xff	Reserved		

**Extended MAC Command Set for IEEE802.15.6**

⇒ Extended IEEE802.15.4 MAC Command Set

## Proposed MAC Commands for IEEE802.15.6

### Device State Request:

Octets: 2	1	0/2 + 0/2/8 + 0/2 + 0/2/8	0/5/6/10/14	1	1	1	2
Frame Control	Sequence Number	Addressing Fields	Auxiliary Security Header	Device State	Stream Index	Device State Request Command ID	FCS
MHR						MAC Payload	MFR

- Used to by a BAN coordinator to request device status from BAN devices
- In response to this request, a BAN device sends a data frame with the **device state flag** in the frame control set to 1 and the **device state octet set to the appropriate status**, both in the MAC header



## Proposed MAC Commands for IEEE802.15.6

### Emergency State Notification :

Octets: 2	1	0/2 + 0/2/8 + 0/2 + 0/2/8	0/5/6/10/14	1	1	1	1 bit	2
Frame Control	Sequence Number	Addressing Fields	Auxiliary Security Header	Device State	Stream Index	Emergency Notification Command ID	Emergency Bit	FCS
MHR						MAC Payload		MFR

- Used by BAN device or BAN coordinator to **raise an emergency** (Emergency Bit = 1) or to **lift a state of emergency** (Emergency Bit = 0)

## Proposed MAC Commands for IEEE802.15.6

### Handover Command :

Octets: 2	1	0/2 + 0/2/8 + 0/2 + 0/2/8	0/5/6/10/14	1	1	1	Variable	2
Frame Control	Sequence Number	Addressing Fields	Auxiliary Security Header	Device State	Stream Index	Handover Command ID	List of Alternative Coordinator ID(s)	FCS
MHR						MAC Payload		MFR

- Used by a BAN coordinator to request the BAN device to disassociate from the current coordinator and associate to another coordinator
- A list of potential coordinators is provided for the BAN device to associate to.

# Proposed MAC Commands for IEEE802.15.6

## Stability Notification Command:

Octets: 2	1	0/2 + 0/2/8 + 0/2 + 0/2/8	0/5/6/10/14	1	1	1	Variable	2
Frame Control	Sequence Number	Addressing Fields	Auxiliary Security Header	Device State	Stream Index	Stability notification ID	Reason for Instability	FCS
MHR						MAC Payload		MFR

- Optional payload
- From a device to a coordinator without a payload, then the device is notifying the coordinator that it is simply unstable.
- From a device to a coordinator with a payload that specifies the reason for its instability; or
- From a device with a payload that contains the ID of other unstable devices which are routing traffic through it.
- From a coordinator to a device with a payload, then the coordinator is notifying the device that the device is unstable, with a payload message to the device as to what action to take.

## Proposed MAC Commands for IEEE802.15.6

### Probe Test Packet Command:

Octets: 2	1	0/2 + 0/2/8 + 0/2 + 0/2/8	0/5/6/10/14	1	1	1	Variable	2
Frame Control	Sequence Number	Addressing Fields	Auxiliary Security Header	Device State	Stream Index	Test Packet command ID	Eg. Bit =1 Multiple antennas	FCS
MHR						MAC Payload		MFR

- This command initiates a probing process to test the quality of the channel between the two BAN devices.

# Proposed MAC Commands for IEEE802.15.6

## Antenna Change Request:

Octets: 2	1	0/2 + 0/2/8 + 0/2 + 0/2/8	0/5/6/10/14	1	1	1	2
Frame Control	Sequence Number	Addressing Fields	Auxiliary Security Header	Device State	Stream Index	Antenna change Request command ID	FCS
MHR						MAC Payload	MFR

- Used in the probing process to request a BAN device to change its radiation pattern configuration.

# Proposed MAC Commands for IEEE802.15.6

## Streaming Request:

Octets: 2	1	0/2 + 0/2/8 + 0/2 + 0/2/8	0/5/6/10/14	1	1	1	As specified by IEEE802.15.3 with variations (see below)	2
Frame Control	Sequence Number	Addressing Fields	Auxiliary Security Header	Device State	Stream Index	Stream Request Command ID	Stream Request Payload	FCS
MHR						MAC Payload		MFR

- As per IEEE802.15.3
- Used by a BAN device to [request a new stream or modify an existing stream](#)
- Stream Request command is equivalent to the Channel Time Request command of IEEE802.15.3 with the following modifications:
  - The *DSPS* octet in the Channel Time Request field [Section 7.5.6.1 of IEEE802.15.3 ] is eliminated; and
  - *Ctrl control* in the Channel Time Request field [Section 7.5.6.1 of IEEE802.15.3 ] is eliminated.

# Proposed MAC Commands for IEEE802.15.6

## Streaming Request Response:

Octets: 2	1	0/2 + 0/2/8 + 0/2 + 0/2/8	0/5/6/10/14	1	1	1	As specified by IEEE802.15.3 with variations (see below)	2
Frame Control	Sequence Number	Addressing Fields	Auxiliary Security Header	Device State	Stream Index	Stream Response Command ID	Stream Response Command Payload	FCS
MHR						MAC Payload		MFR

- Used by coordinator, in response to stream Request, to inform a BAN device about [allocation / disallocation of stream](#) for the requesting device
- Stream Response command is similar to the Channel Time Response command of IEEE802.15.3 with minor modifications.
  - The *reason code* in the Channel Time Response command payload is modified to eliminate the following reason code values:
    - *Success, device in save mode;*
    - *Priority unsupported;*
    - *Destination in power save mode;* and
    - *Unable to allocate as pseudo-static Channel Time Allocation.*

# Proposed MAC Frame Types for IEEE802.15.6

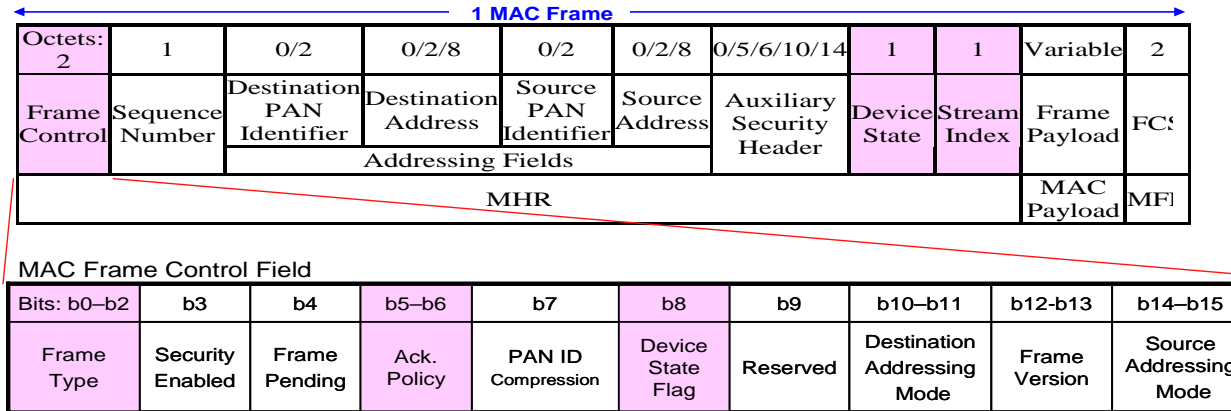

Frame type value b2 b1 b0	Description
000	Beacon
001	Data
010	Acknowledgement
011	MAC command
100	Immediate Acknowledgement
101	Delayed Acknowledgement
110-111	Reserved

- **Add** in two new frame types
  - *Immediate ACK (see next slide)*
  - *Delayed ACK (see next slide)*



# Proposed ACK Types for IEEE802.15.6

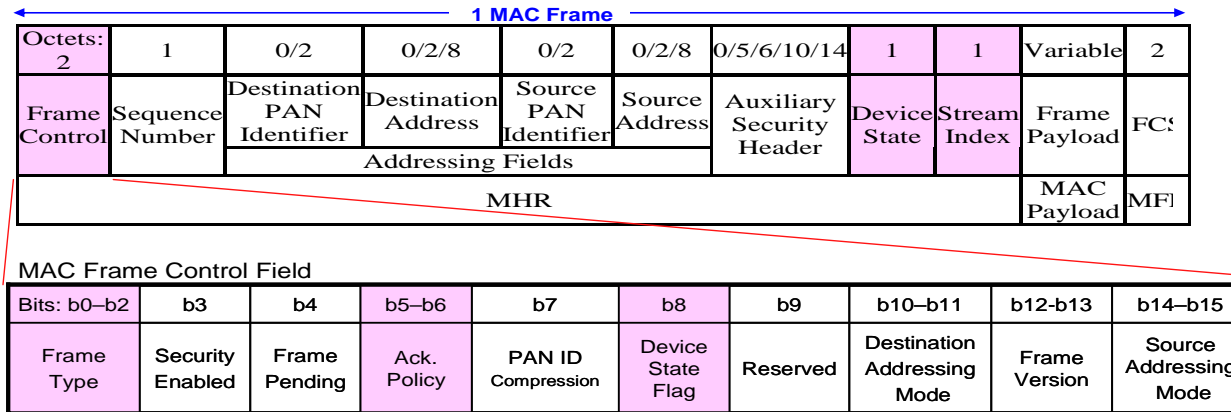

ACK Type b6 b5	Description
00	No ACK
01	ACK
10	Delayed ACK
11	Immediate ACK

- **ACK** – sent at the *earliest opportunity*, when one is requested
- **Immediate ACK** – sent *immediately* when one is requested in the MAC header of a MAC Command frame or a Data frame
- **Delayed ACK** – sent *after a number of transmitted frames*, acknowledging receipt of multiple frames in the Delayed ACK payload, following receipt of a '0' Frame Pending bit

# ACK Frames for IEEE802.15.6

## ACK / Immediate ACK

Octets: 2	1	0/2 + 0/2/8 + 0/2 + 0/2/8	0/5/6/10/14	1	1	2
Frame Control	Sequence Number	Addressing Fields	Auxiliary Security Header	Device State	Stream Index	FCS
MHR						MFR

## Delayed ACK

Octets: 2	1	0/2 + 0/2/8 + 0/2 + 0/2/8	0/5/6/10/14	1	1	Variable	2
Frame Control	Sequence Number	Addressing Fields	Auxiliary Security Header	Device State	Stream Index	Delayed ACK Payload	FCS
MHR						MAC Payload	MFR

## Device States for IEEE802.15.6

→ Used in generating response to “Device State Request” MAC Command

- Indicates **different urgency levels** of an emergency state and **different battery levels** for a device.
  - Urgency and Battery levels can be used independently
- Device state is only interpreted when the **device state flag** in the MAC Frame Control (b8 = 1) is set to one.
- Device state **may be published upon request** by a coordinator using a Device State Request command
- Device state **may be used for BAN management** by a coordinator and / or an application (e.g. for adaptive duty cycling, or for optimised channel access).

Bits: b0–b1	B2-b3	b4-b8
Urgency levels	Battery levels	Reserved

## Streaming Index for IEEE802.15.6

- **Stream index** is proposed as defined in IEEE802.15.3 to provide streaming capability
  - ECG, EEG are considered as medical streams
- **Prioritisation of streams** may be performed when preceded by an Emergency Notification command or if the Device State octet is set as specified in the MAC Frame Header.
- **Emergency streams** have **higher priority** than non-emergency streams
- **Medical streams** have **higher priority** than non-medical streams

## Potential Protocols for Exploitation of Proposed MAC frame

# Congestion Control

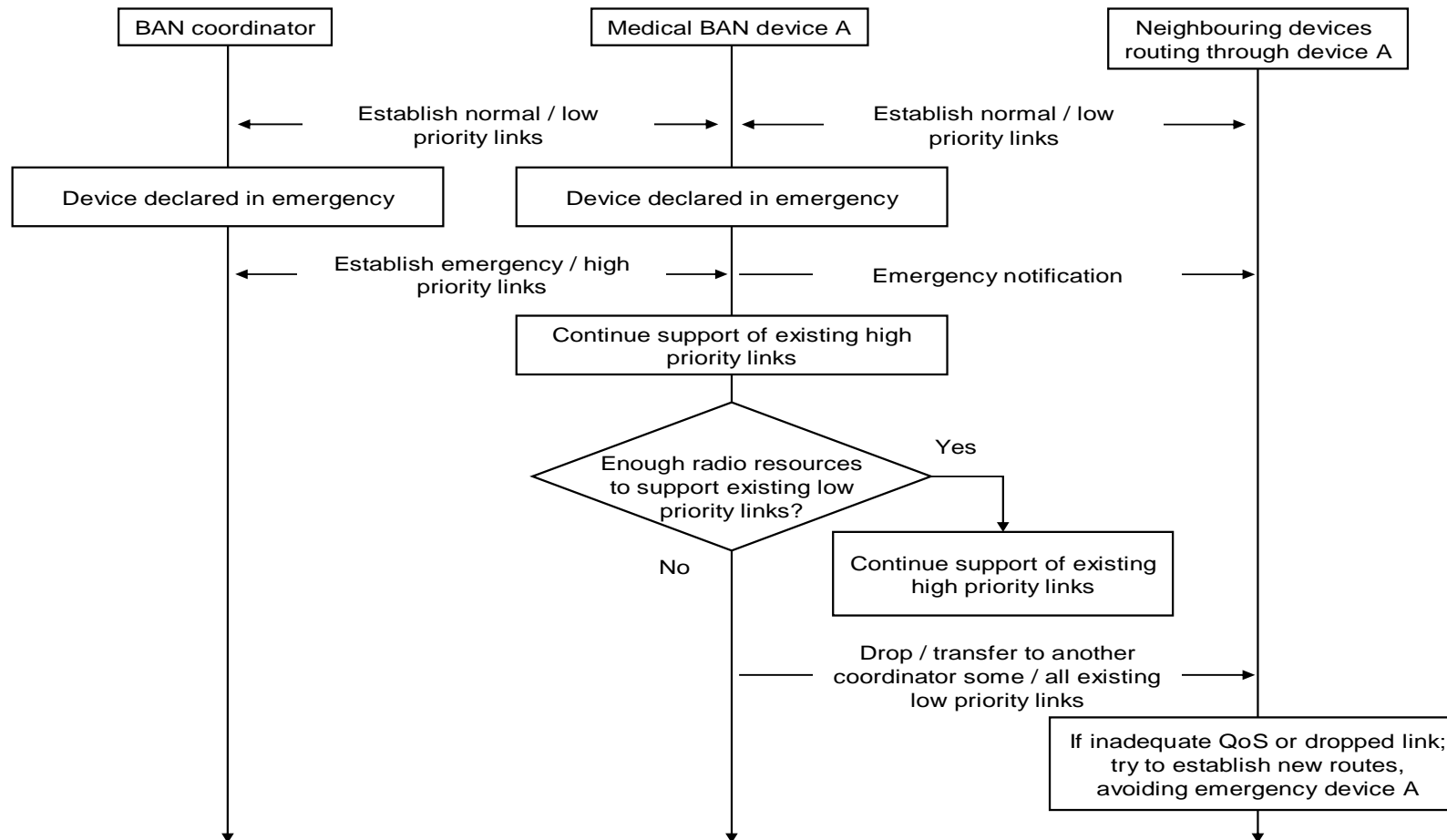

- Star / mesh topology
- Device A in state of emergency
  - Continues to route high-priority traffic;
  - May also support low-priority traffic if resources available.

# Congestion Control

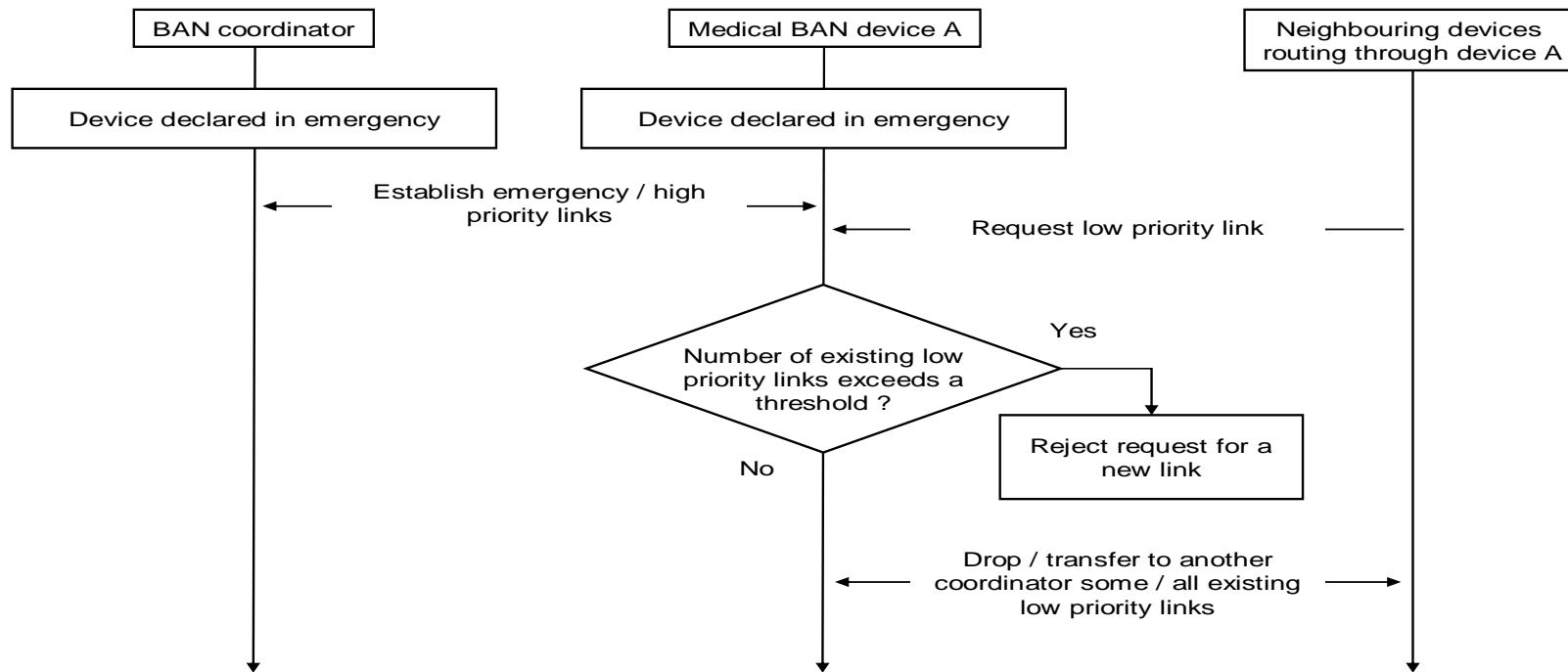

- Star / mesh topology
- For devices in state of emergency
- Device A is in a state of emergency
  - Stops routing high-priority traffic
  - May support low-priority traffic if resources available
- Congestion control make use of **emergency Notification Command** or **Device State** to detect a state of emergency

## Stability Management- Multi-Hop/Mesh Topology

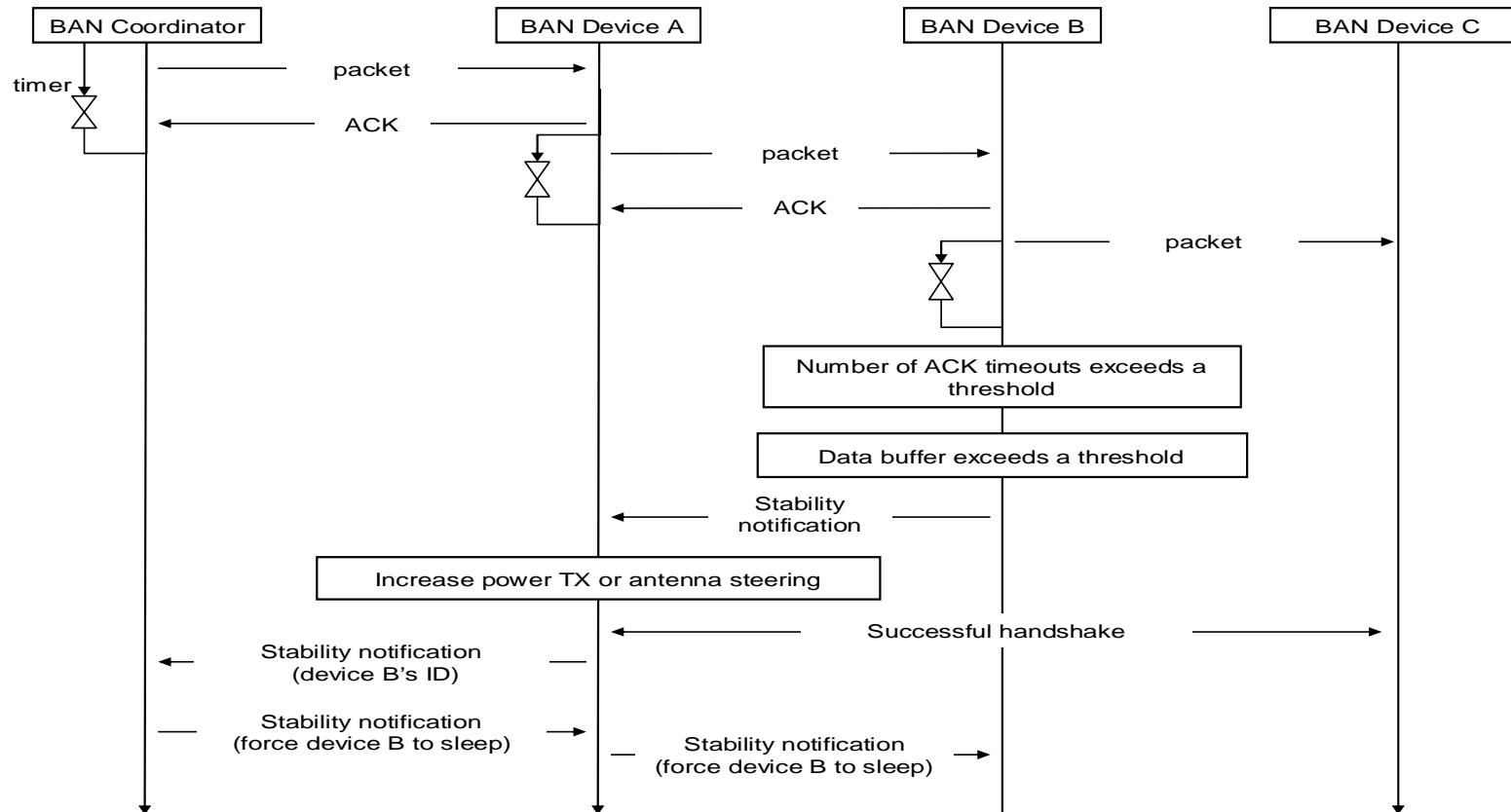

- Based on a number of missed ACKs.
- A device is considered to be unstable or a point of failure if a predefined number ACKs are missed.
- An ACK is considered missed after a predefined timeout period after sending a message that requires acknowledgement.
- **Stability Notification command** is used to notify BAN coordinator or other BAN devices



# Stability Management - Star Topology With Switching Antenna

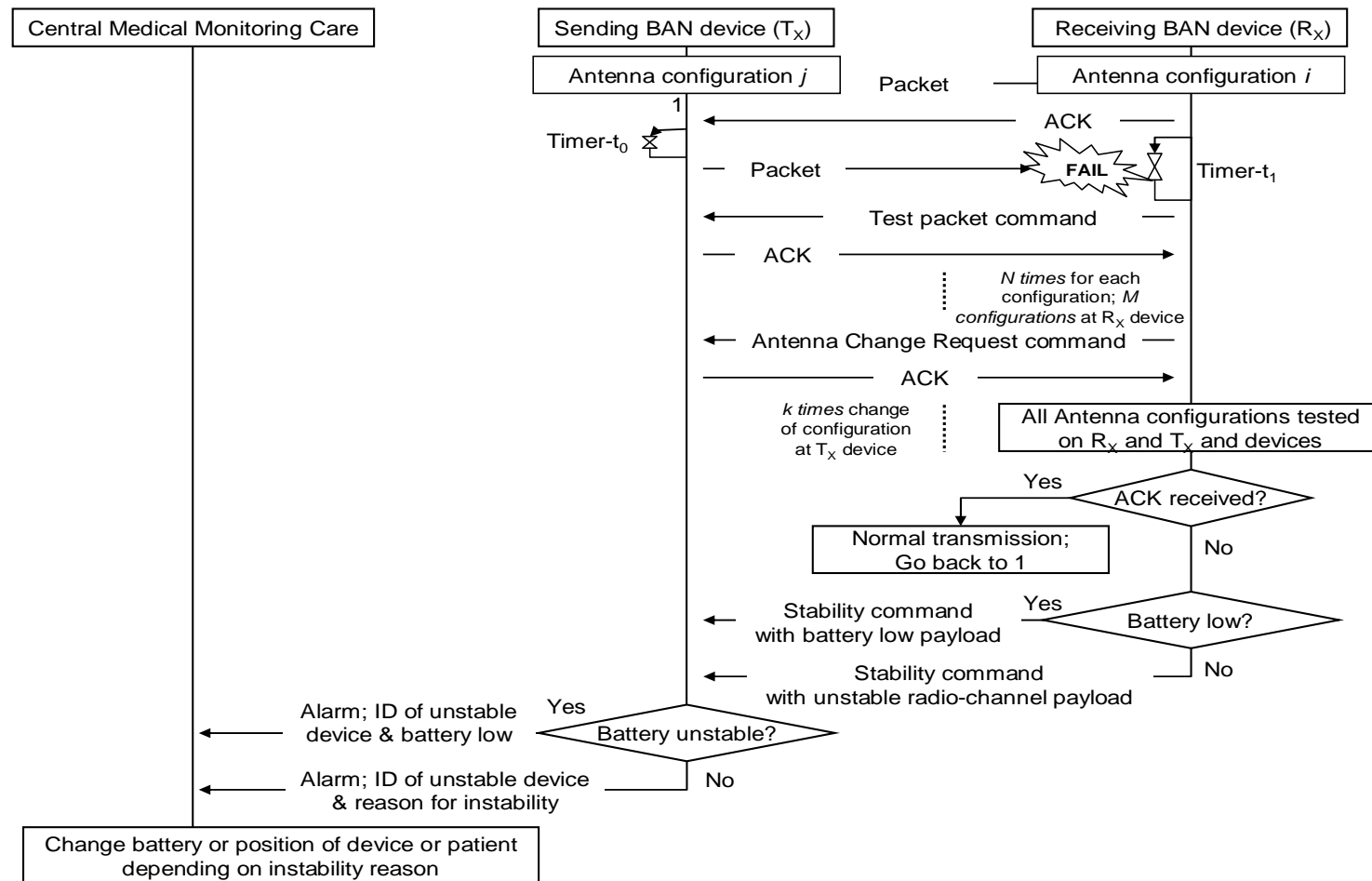

- Switching between different antennas or different radiation pattern to improve the quality of channel
- Initiated by BAN device in process of receiving data when it has not received the next data packet after a predefined timeout
- Two phases: Probing using *Test Packet command* and Antenna Change using *Antenna Change Request command*
- Assessment of stability or quality of link is based on *access rate of ACKs* corresponding to test packets

# Handover Procedure

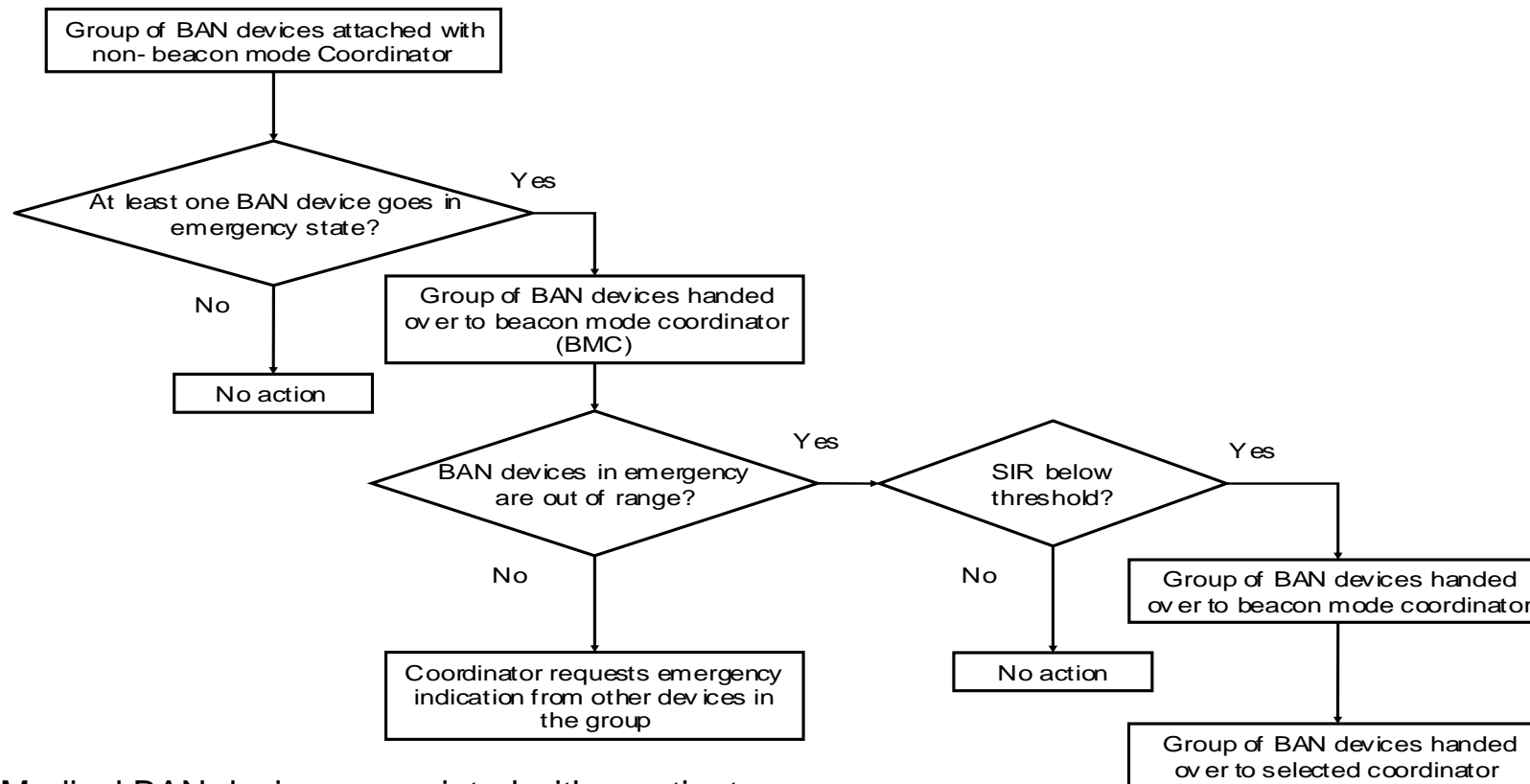

- Medical BAN devices associated with a patient
- Medical **BAN on move without exclusive coordinator** in a closed environment such as hospital
- **Multiple coordinators** operating in **various network modes, beacon and non-beacon**, for different situations and they assist the BAN devices to perform the **handover to the appropriate coordinator depending on several factors**:
  - *At least one device in a group goes into emergency;*
  - *Location of the group with at least one device in a state of emergency relative to the current coordinator;*
  - *Location of the group with at least one device in a state of emergency relative to the current coordinator and SIR*

# Handover Protocol

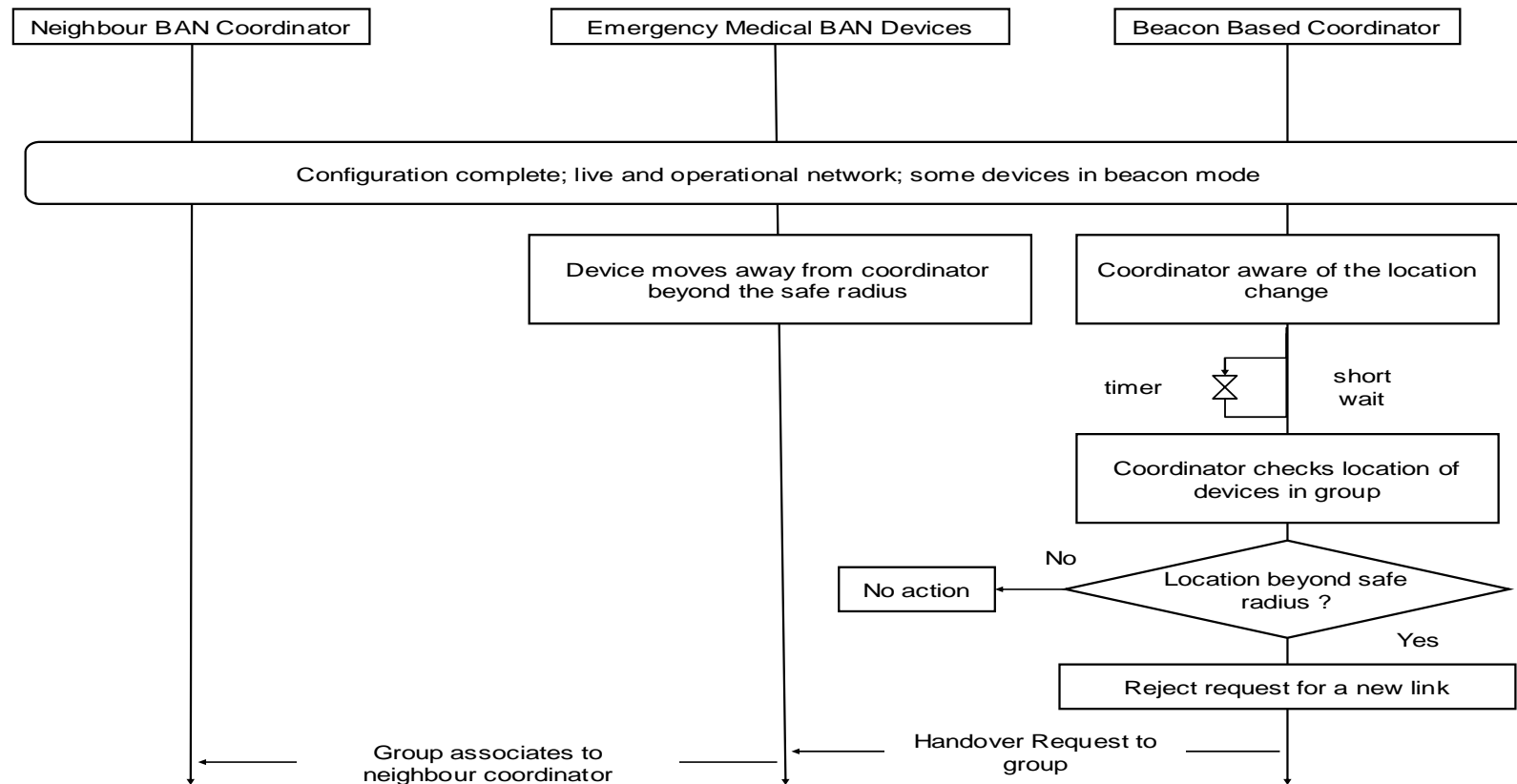

- Triggered when distance of the BAN device, in emergency, of BAN group associated with a patient goes beyond a predetermined radius for reliable communication
- **Handover MAC command** is used to trigger the process of disassociating from one coordinator and associating with another
  - Handover payload lists potential suitable target coordinators with which the device can associate with

## On Demand Data Stream Scheduling According To QoS

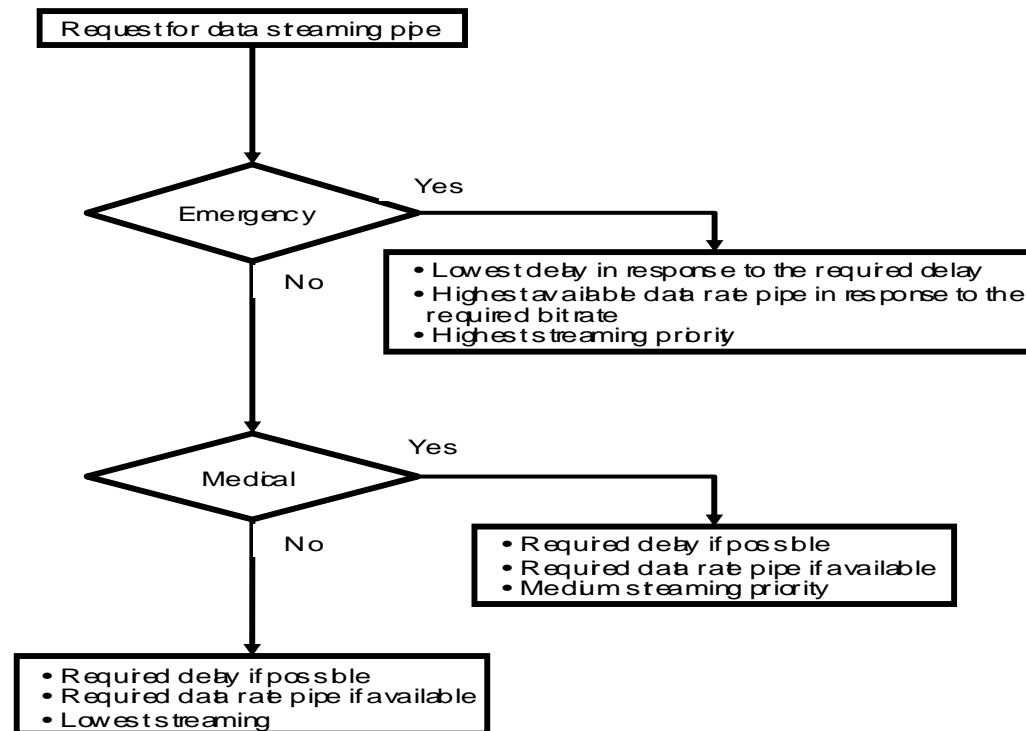

- Provision of different QoS through the combination of stream index and **Emergency Notification command or the Device State octet**
- Medical and non-medical *emergency streams* are given highest over other traffic
- *Medical streams* are given higher priority over non-medical streams

## On Demand Data Stream Scheduling According To QoS

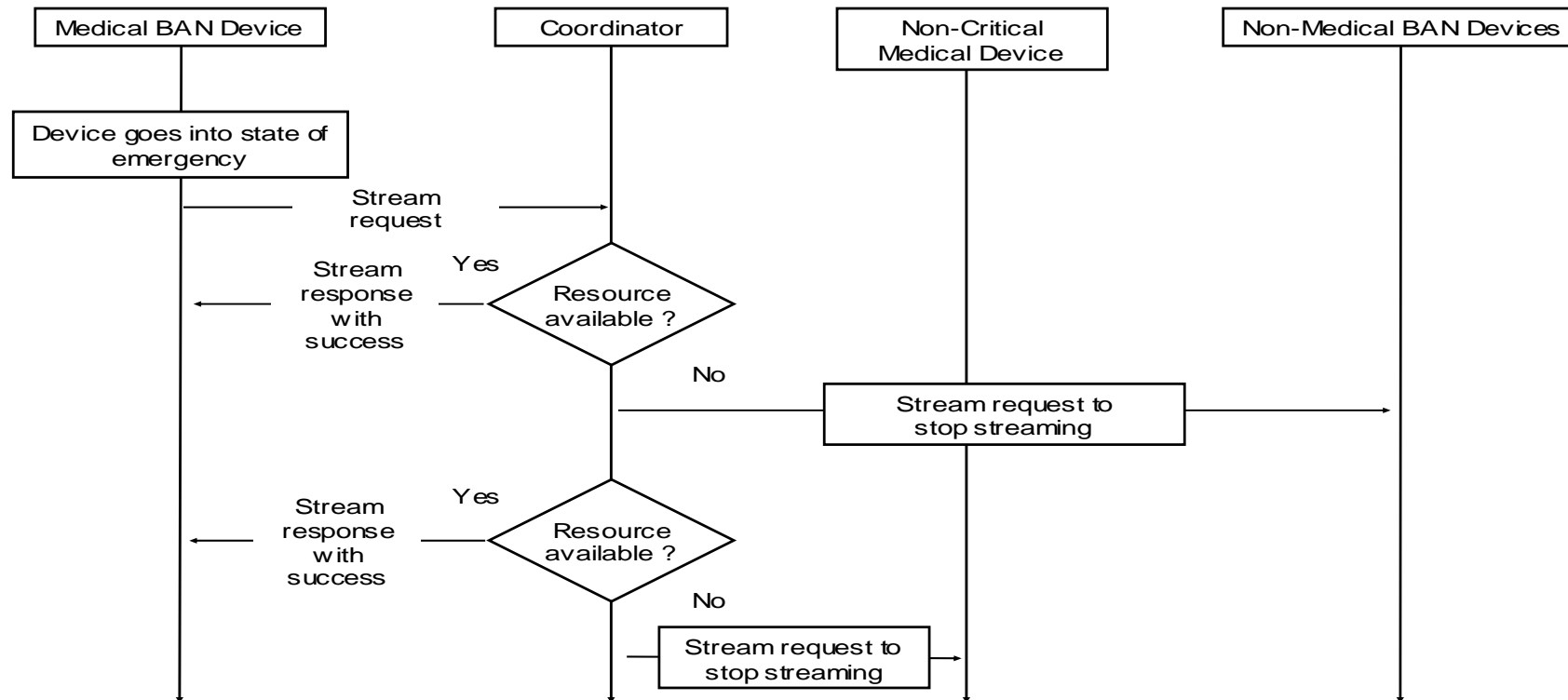

- Prioritisation mechanisms associated with stream scheduling are dynamic.
  - In response to the lifting of an emergency, the streaming of non-emergency and non-medical data may be resumed automatically by reallocation of streaming resources.
  - Allows for the slowing down, or temporarily stopping, of non-medical streaming when emergency data is present.

## Emergency Induced Switching Between Different Channel Access

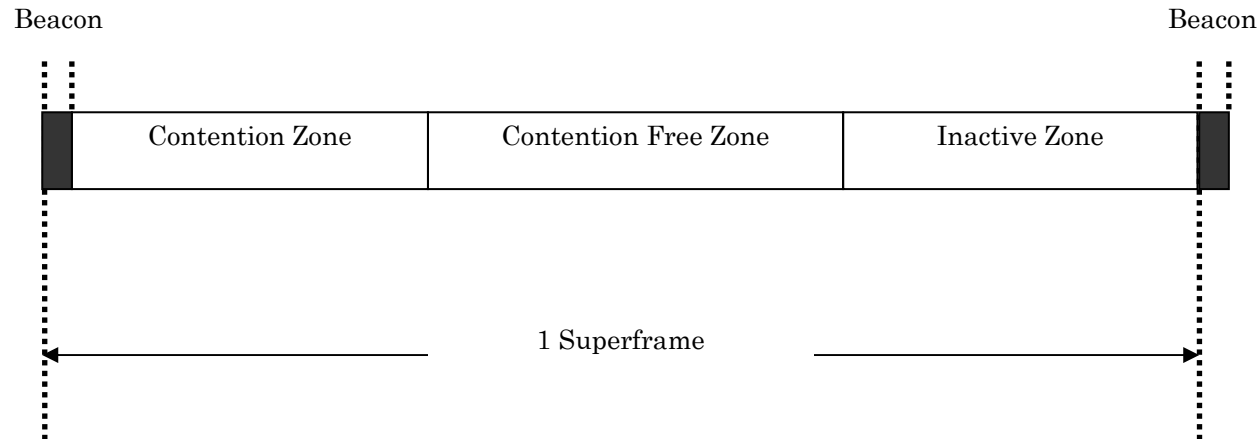

- BAN devices initially operate in non-beacon mode and with low duty cycles under normal conditions.
- As the urgency level of an emergency situation is raised as a result of an **abnormality** in the measurement or as a result of **low battery level**, thus switching into a more synchronised network modes of operation, such as the beacon mode.
- In the beacon mode, channel access follows a superframe structure which consists of three zones: 1) contention based zone, 2) contention free zone and 3) inactive zone.
- **Emergency Notification command or the Device State**, which includes urgency levels and battery levels, can be considered as potential criteria for switching between different network modes, such as non-beacon mode and beacon mode depending on the criticality of the BAN conditions.

## Adaptive duty cycling

- Adaptive duty cycling for adaptive channel access and for emergency management in the BAN through the exploitation of **device state**
- BAN device duty cycle may be adapted depending on the severity of the emergency as identified by the device or the coordinator.
- The two “urgent” bits in the device state octet, “u1 u2”, differentiate levels of emergency may be mapped to different duty cycles (see next slide)
- Adaptation of duty cycle may take into consideration battery levels in the device state (see next slide)

# Adaptive Duty cycling

Device State Urgent Bits: "u1 u2"	Example Emergency Level	Thresholds	Example Duty Cycling
00	Device in normal condition	measurement < Th1	<b>Low Wakeup: Longest sleep time, very low duty cycle</b>
01	Device in slightly abnormal condition	Th1 < measurement < Th2	<b>Medium Wakeup: Slight increase of duty cycle</b>
10	Device in abnormal condition	Th2 < measurement < Th3	<b>High Wakeup: Increase of duty cycle</b>
11	Device in emergency	Th3 < measurement	<b>Continuous Wakeup: Dramatic increase of duty cycle or continuous wake mode</b>

Battery		Example Duty Cycle			
Device State Battery bits: "b1 b2"	Battery Levels	Low Wakeup	Medium Wakeup	High Wakeup	Continuous Wakeup
00	L1=0%-25%	✓	✗	✗	✗
01	L2=25%-50%	✓	✓	✗	✗
10	L3=50%-75%	✓	✓	✓	✗
11	L4= 75%-100%	✓	✓	✓	✓



# Summary

1. PHY elements for IEEE802.15.6
  - ✓ Sleep and Wake-up mode employing dual-PHY for Narrow band (for Energy Saving)
    - ✓ [For very low rate communication \(interrogation\) under sleep-mode](#)
  - ✓ Channel probing mode to mitigate the shadowing effect (for Stable communication)
    - ✓ Series of channel probing packet transmission at each antenna configuration when the communication is deteriorated by shadowing effect
2. MAC elements for IEEE802.15.6
  - ✓ MAC Frame structure based IEEE802.15.4 and IEEE802.15.3 for data and commands
    - ✓ Emergency framework for BAN,
    - ✓ Streaming capability
    - ✓ Enabling provision of different QOS
    - ✓ Stability management
    - ✓ Congestion Management
  - ✓ Potential protocol exploiting MAC frame structure for
    - ✓ Congestion Management
    - ✓ stability Management
    - ✓ Handover Management
    - ✓ On-demand scheduling for channel access
    - ✓ Triggering criteria for switching between different network mode

END