

Project: IEEE P802.15 Working Group for Wireless Personal Area Networks (WPANs)

Submission Title: PSSK Proposal for High-data-rate In-body WBAN PHY (ETRI)

Date Submitted: March 10, 2009

Source: [Dong Kyoo Kim¹, Cheolhyo Lee¹, Hyung Soo Lee¹, Jung Yeol Oh¹, Jae Young Kim¹, Yangmoon Yoon², KiBum Kwon²]

Company: [ETRI¹, KORPA²]

Address: [ETRI¹, 138 Gajeong-ro, Yuseong-gu, Deajeon, 305-700, South Korea, KORP²A, 78 Garak-dong, Songpa-gu, Seoul, 138-803, South Korea]

Voice: [+82-42-860-5625¹, +82-2-2142-2483²], **FAX:** [+82-42-823-5218¹, +82-2-2142-2155²],

E-mail: [kdk3606@etri.re.kr¹, clee7@etri.re.kr¹, hsulee@etri.re.kr¹, juoh@etri.re.kr¹, jyk@etri.re.kr¹, ymyoon@korpa.or.kr², wrecker@korpa.or.kr²]

Re: This document is ETRI's response to the Call For Proposal from the IEEE P802.15 Task Group 6 on BAN.

Abstract: This document presents PSSK for High-data-rate In-body WBAN.

Notice: This document has been prepared to assist the IEEE P802.15. It is offered as a basis for discussion and is not binding on the contributing individual(s) or organization(s). The material in this document is subject to change in form and content after further study. The contributor(s) reserve(s) the right to add, amend or withdraw material contained herein.

Release: The contributor acknowledges and accepts that this contribution becomes the property of IEEE and may be made publicly available by P802.15.

Presentation Outline

- **Requirements**
- **Recommended Frequency Band**
- **Proposed PHY**
- **Reliability**
- **Link Budget**
- **Spectral Mask and Channelization**
- **Conclusion**

Applications of High-data-rate In-body WBAN

- Applications of Implantable BAN
 - Capsule Endoscope
 - Drug Delivery & Monitoring Capsule
 - Bionic & Telescopic Eye
 - Implant Hearing Aid
- Image resolution
 - Image quality at least 2.3Mbps
 - Enlarge the image for specific symptom
 - HD image : up to 20Mbps

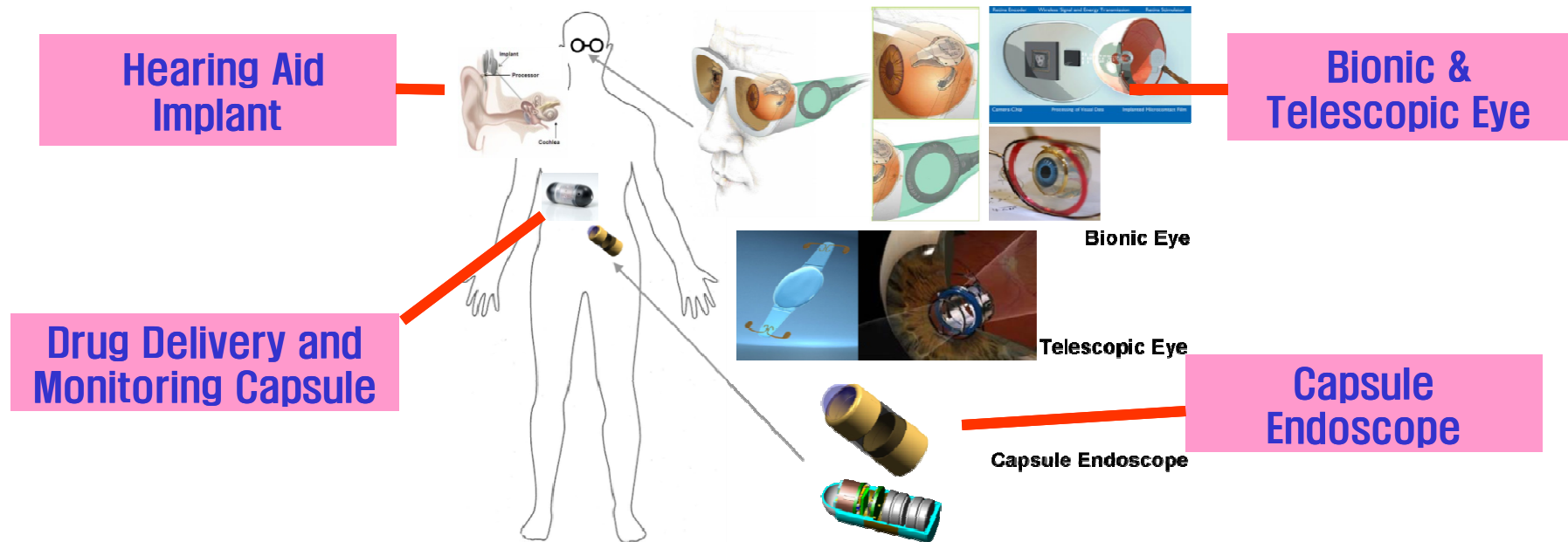

Requirements for High-data-rate In-body WBAN

Parameters	Requirement
Raw PHY data rate	10 Mbps, 20 Mbps
Transmission range	30 cm * / 3 m **
Reliability	BER < 10 ⁻⁶

* Due to the great signal strength attenuation by deeply-implanted devices in human body, transmission range is limited to several tens of centimeter.

** For non deeply-implanted devices such as bionic eye, transmission range is up to 3 meters.

Considerations of Frequency Band

- No dedicated frequency band for implant device
- Zarlink (IEEE 802.15-08-162-00)
 - Frequency band: 400-440MHz band
 - Regulation problem
 - Band usage for other countries: land mobile or walkie-talkie
- Frequency considerations for implant device
 - Sub-900MHz band: due to in-body attenuation
 - Required bandwidth: at least 40MHz for 10Mbps or 20Mbps

FCC Regulation

- FCC Part15.209 (Radiated emission limits)
 - Unlicensed general requirements

Frequency (MHz)	Electric field strength (uV/m)	Measuring distance (m)	EIRP (dBm)
30 ~ 88	100	3	-55.3
88 ~ 216	150	3	-51.7
216 ~ 960	200	3	-49.2
Above 960	500	3	-41.25

Korea Regulation

- Korea
 - Unlicensed general requirements

Frequency (MHz)	Electric field strength (uV/m)	Measuring distance (m)	EIRP (dBm)
~322MHz	500	3	-41.25
322MHz ~ 10 GHz	35	3	-64.35
10 GHz ~ 150 GHz	$3.5 \times f(\text{GHz})$ Max. 500	3	$-84.35 + 20\log(f)$

* Power regulation in Japan is the same as in Korea

Recommended Frequency Band

- Unlicensed low-power transmission
 - -49.2dbm(FCC)
 - -41.25dBm(Korea)
- Consideration of in-body transmission
 - Small antenna size
- Frequency band
 - 270~310MHz

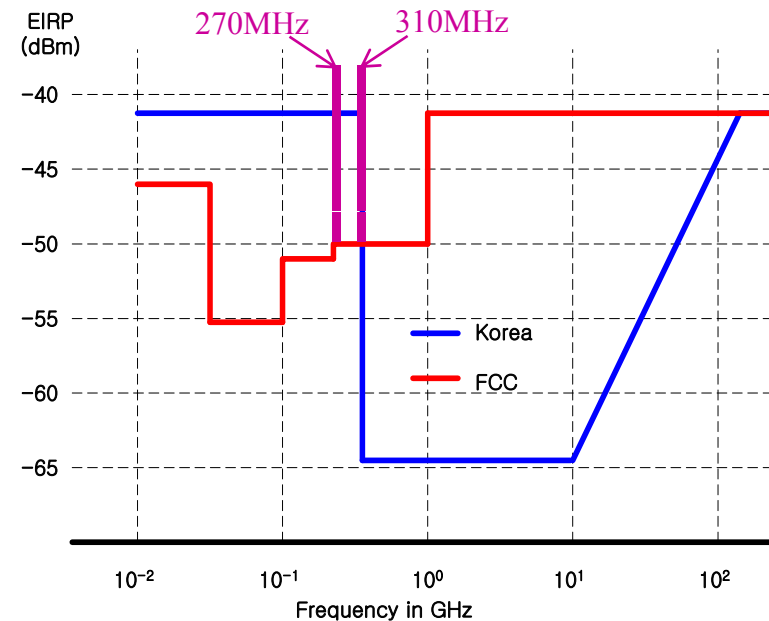

Trends of Wireless Implant Devices

- Implant wireless communication devices
 - Low-data-rate
 - Zarlink: 200/400/800kbps, FSK
 - High-data-rate
 - Capsule endoscope: Up to 3 Mbps, Several vendors and research institutes, FSK/OOK
- Modulation methods
 - FSK, PPM (Orthogonal modulations) are power efficient, but they have low bandwidth efficiency.
 - FSK, PPM are suitable for low-data-rate modulations.

	BPSK	QPSK	8PSK	16PSK	32PSK
Bandwidth efficiency	0.5	1	1.5	2	2.5
	2BPPM	4BPPM	8BPPM	16BPPM	32BPPM
Bandwidth efficiency	0.5	0.5	$3/8=0.375$	$1/4=0.25$	$5/32=0.15625$
	Orth-BFSK	Orth-4FSK	Orth-8FSK	Orth-16FSK	Orth-32FSK
Bandwidth efficiency	1	0.25	$1/6=0.167$	$1/10=0.1$	$1/18=0.056$

Proposed PHY for High-data-rate In-body Communication

- Design objective
 - Power efficient modulation
 - (Frequency) bandwidth efficient modulation
 - > Overcome the disadvantage of Phase Shift Keying
 - Pros : Bandwidth efficient
 - Cons : Less power efficient than orthogonal modulations
- Phase-Silence Shift Keying (PSSK)
 - Compromise between Power efficient modulation and bandwidth efficient modulation
 - PSSK achieves this by using orthogonal phase spaces.

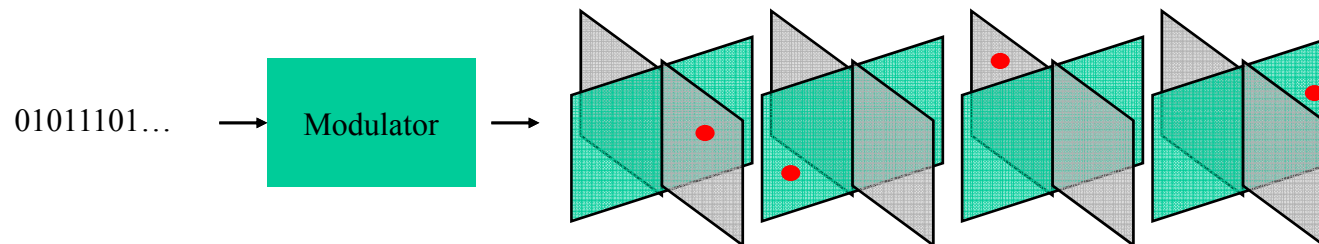

* More details are presented in Appendix.

Comparisons of Modulations : Spectrum

- Spectrum
 - Spectrum efficiency of FSK or PPM is unavailable to high-data-rate WBAN modulation.
 - PSK is the most bandwidth efficient modulation.
 - Bandwidth efficiency of PSSK is half of PSK.
- Signal-bandwidth comparison
 - $f_{\text{fsk,ppm}} : f_{\text{pssk}} : f_{\text{psk}} = (M+1)/2 : 2 : 1$

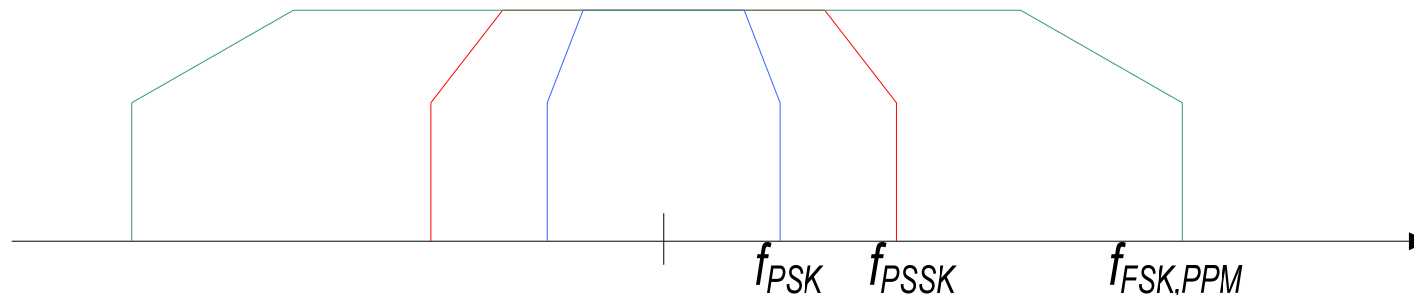

Comparisons of Modulations : Power

- Signal-power comparison

- PSSK is more power efficient by 5 to 6 dB than PSK.
- FSK is more power efficient by 6 dB than PSK for $M=8$
 - As M increases, FSK gets more power efficient than PSK

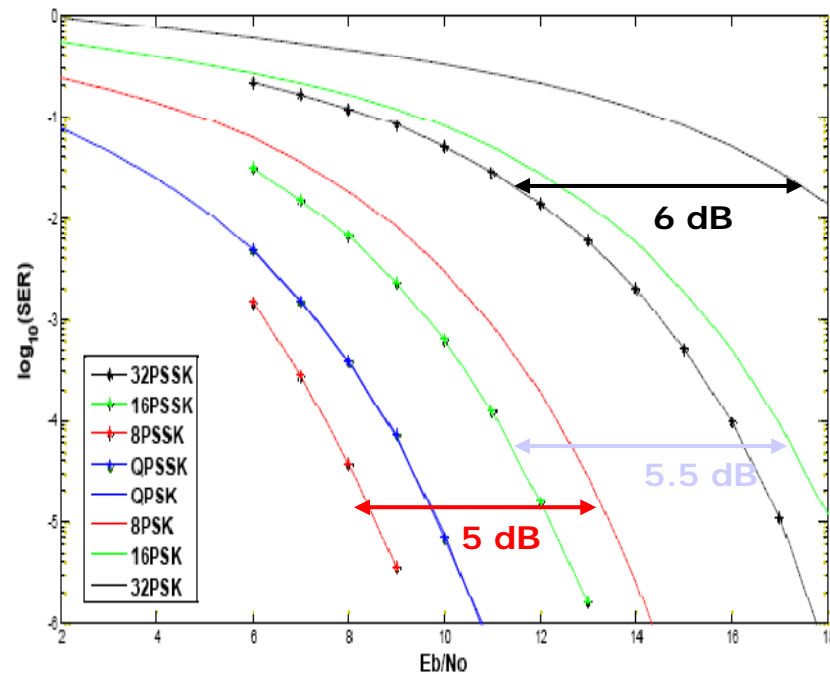

Raw PHY Data-rate

- PSSK Transmitter

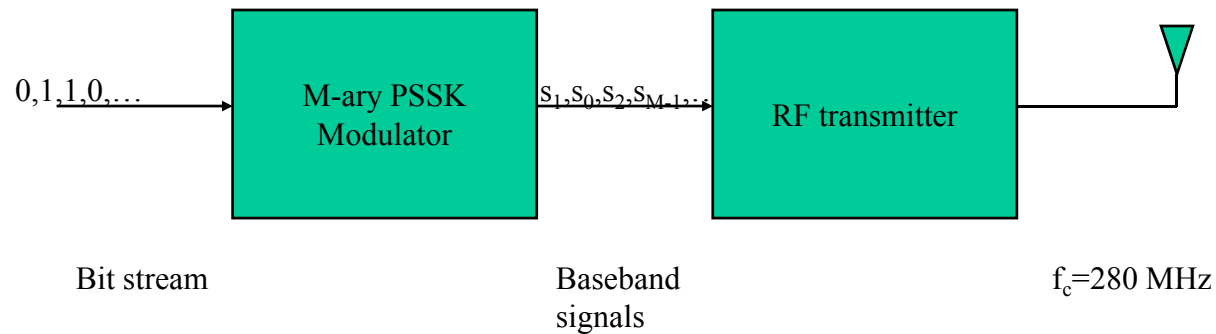

- Data rate: 10 Mbps or 20 Mbps

Mode of Data-rate and Spectrum

- 20 Mbps mode (8-ary PSSK)
 - 3 dB Bandwidth: 11.6 MHz / 5.8 MHz (without / with pulse-shaping)

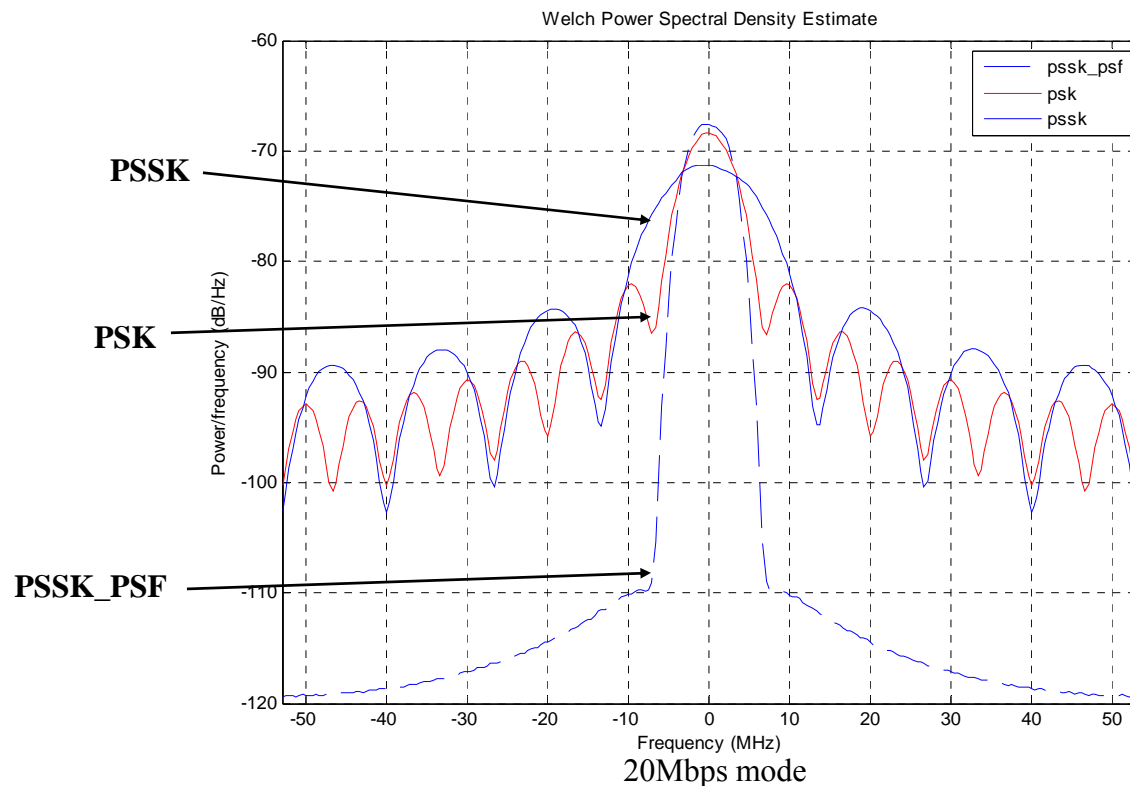

Mode of Data-rate and Spectrum

- 10 Mbps mode (8-ary PSSK)
 - 3 dB Bandwidth: 5.8 MHz / 2.9 MHz (without/with pulse-shaping)

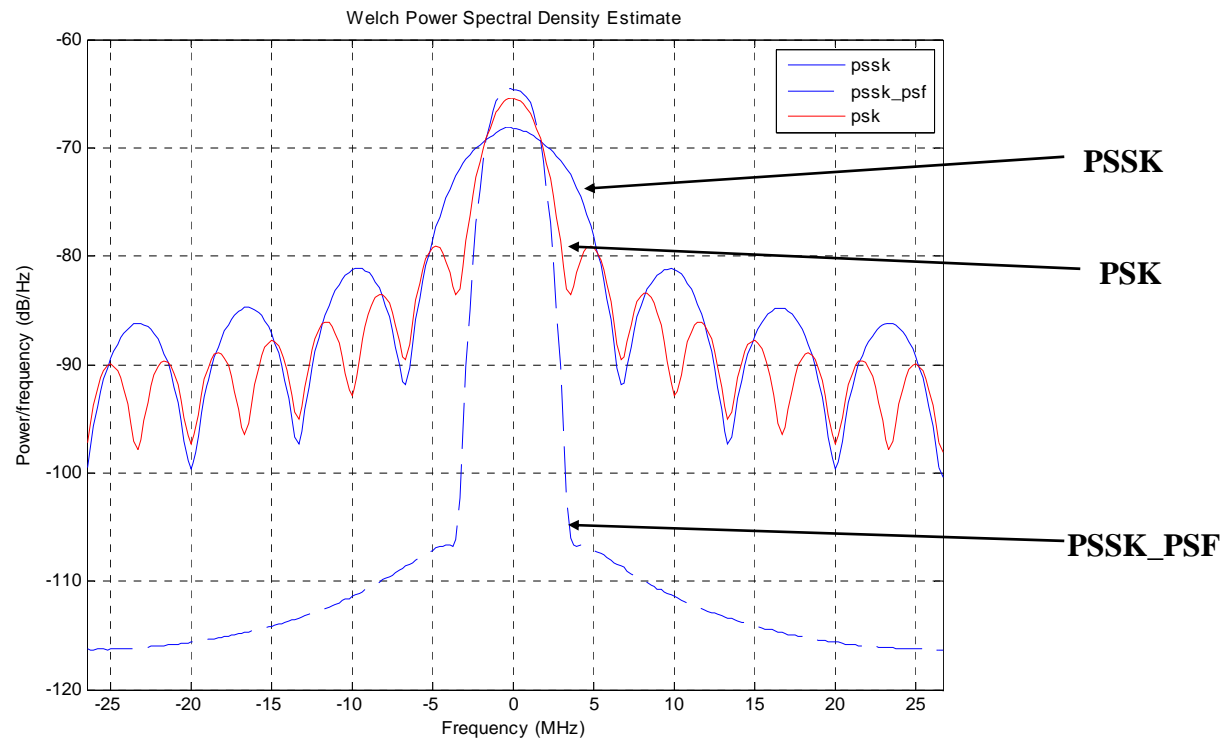

Reliability

- Bit error rate over AWGN channel
 - 8-ary PSSK has $\text{SER}=10^{-6}$ when $E_b/N_0=9\text{dB}$

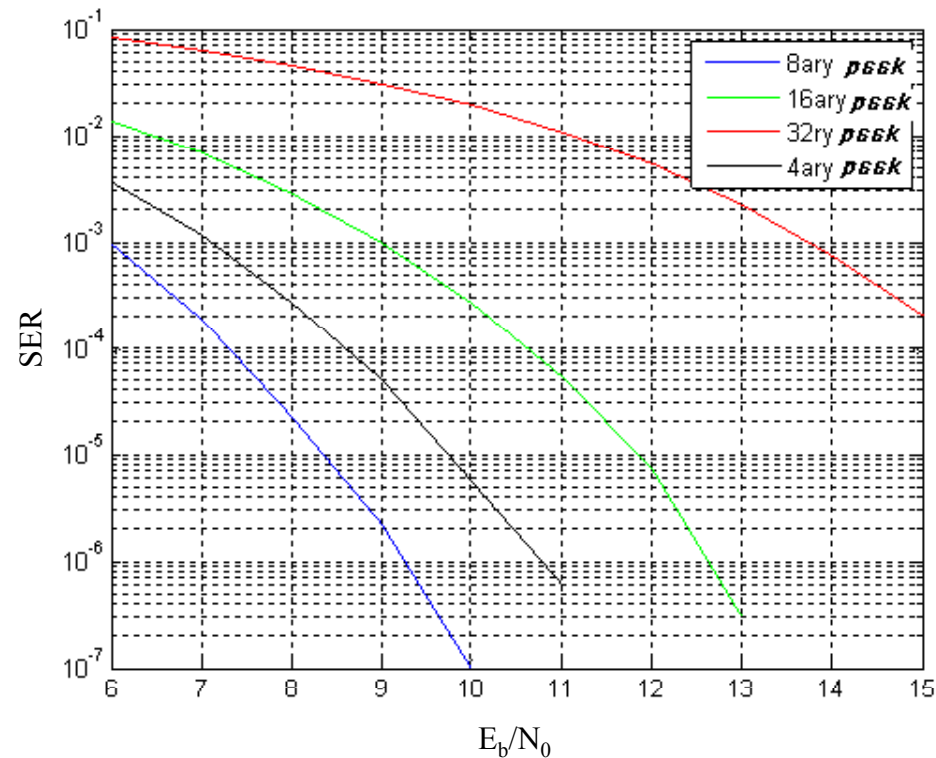

Link Budget

TX-to-RX Distance: 20 cm

- Transmitter in a body
- Receiver on the skin
- Multiple receiver antenna
 - Diversity gain
- Range of Tx power
 - -49~0dbm
 - According to the depth of implanted transmitter

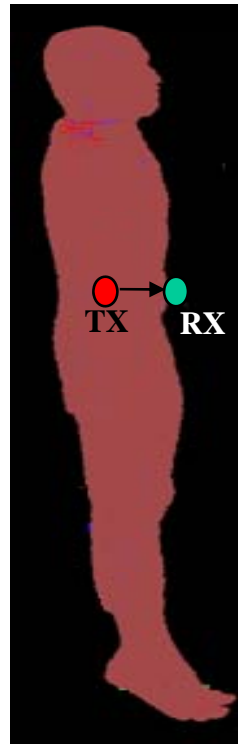

Parameters	Values (20Mbps)	Values (10Mbps)	Unit
Transmit Power	0	0	dBm
TX Antenna Gain	-10	-10	dBi
Body Attenuation	-65	-65	dB
RX Antenna Gain	0	0	dBi
Noise Figure	-5	-5	dB
Implementation Loss	-3	-3	dB
kTB noise	-106	-110	dB
SNR	23	27	
Link Margin	9	13	dB

Spectral Mask and Channelization

- Spectral mask

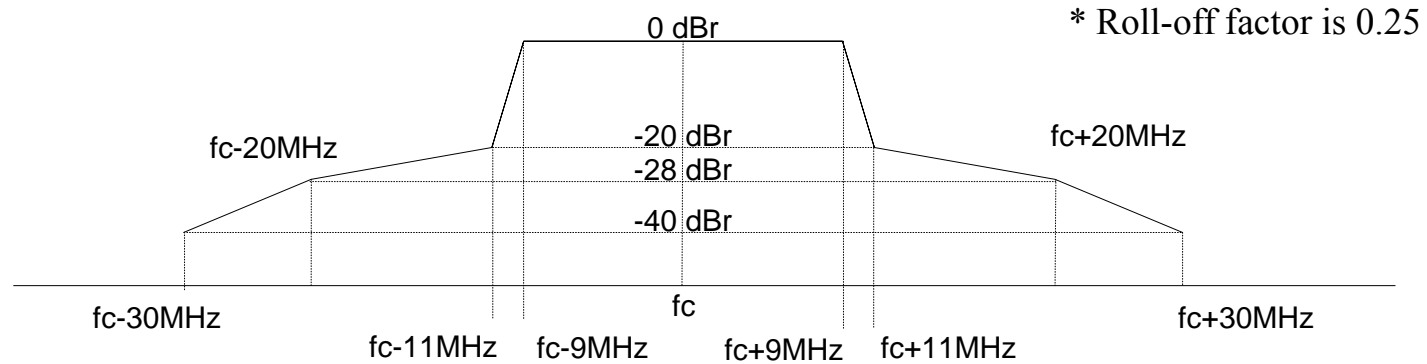

- Bandwidth per channel

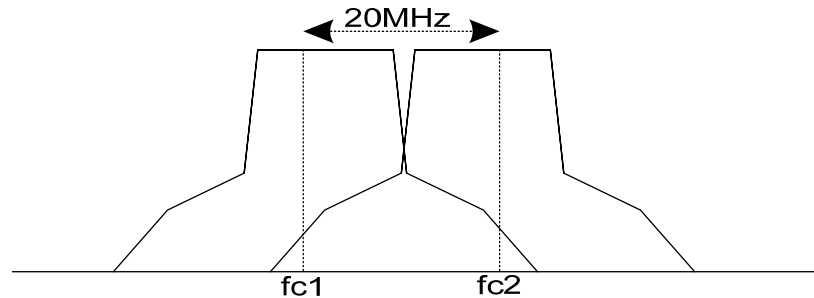

Conclusion

- PSSK was proposed for PHY for high-data-rate WBAN.
- PSSK summary
 - Data rate
 - 10 Mbps, 20 Mbps
 - Channel
 - 2 channels
 - Bandwidth (with pulse shaping)
 - 5.8 MHz (for 20MHz), 2.9MHz (for 10MHz)
 - Link margin
 - If transmit power is 0 dBm, link margin is 9 dB (for 20Mbps) and 13 dB (for 10Mbps.)
 - Due to the attenuation in body, transmission power may be -49~0dbm