

Project: IEEE P802.15 Working Group for Wireless Personal Area Networks (WPANs)

Submission Title: NICT Phy Solution: Part 1: Chirp Pulse Based IR-UWB Physical Layer

Date Submitted: 10 March, 2009

Source: Igor Dotlić and Ryuji Kohno, National Institute for Information and Communication Technology

Address: 3-4, Hikarino-oka, Yokosuka, 239-0847, Japan

Voice: +81-46-847-5066, FAX: +81-46-847-5431, E-Mail: dotlic@nict.go.jp, kohno@nict.go.jp

Abstract: Chirp Pulse Based UWB Physical Layer Proposal for Body Area Networks

Purpose: Response to “TG6 Call for Proposals” (IEEE P802.15-08-0811-02-0006)

Notice: This document has been prepared to assist the IEEE P802.15. It is offered as a basis for discussion and is not binding on the contributing individual(s) or organization(s). The material in this document is subject to change in form and content after further study. The contributor(s) reserve(s) the right to add, amend or withdraw material contained herein.

Release: The contributor acknowledges and accepts that this contribution becomes the property of IEEE and may be made publicly available by P802.15.

NICT Phy Solution: Part 1: Chirp Pulse Based IR-UWB Physical Layer

Igor Dotlić and Ryuji Kohno

National Institute of Information and
Communications Technology (NICT)

Outline

- Motivation
- System principles
- System performance
- Conclusions

Motivation

- IR-UWB is a (strong) candidate for wearable BAN.
- Low power non-coherent IR-UWB systems are sensitive to MAI, NBI and interference from other IR-UWB.
- Systems that are aspiring to be low power (differentially) coherent IR-UWB are still emerging and make significant compromise between system performance and power consumption.
- Is it possible to design a system that is coherent, performs close to the (much more complex) Rake receiver and is low complexity and low power?

SYSTEM PRINCIPLES

Why is linear chirp pulse signal like no other?

Mixing two linear chirp pulses:

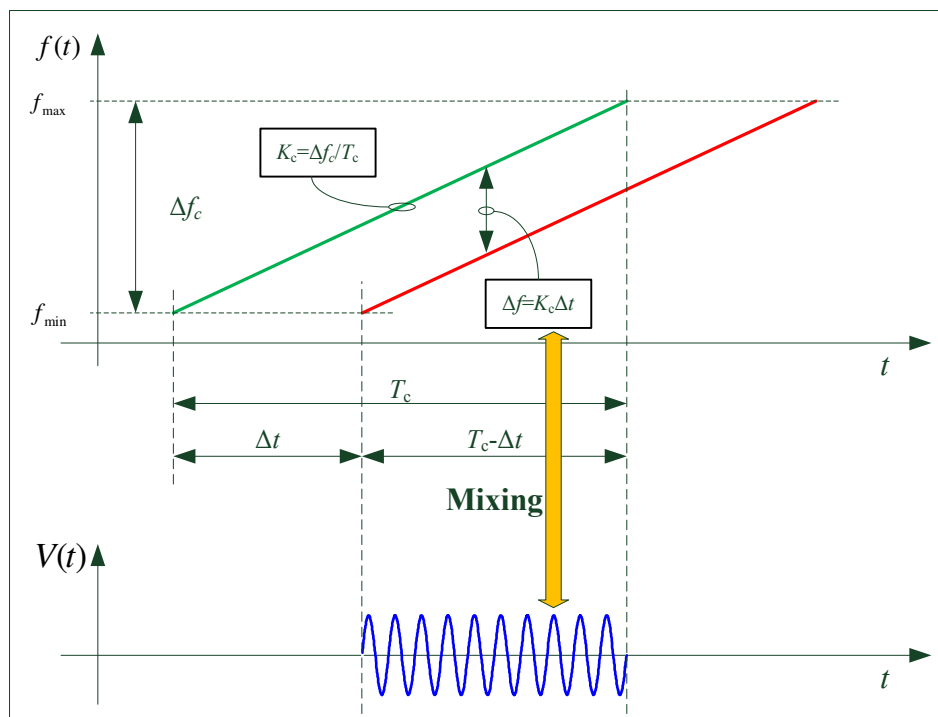

- **It de-spreads the chirp in frequency without de-spreading it in time.**
- Timing does not to be matched well in order to get low-pass signal that contains most of the energy.

Why is linear chirp pulse signal like no other? (cont.)

Effects on multipath:

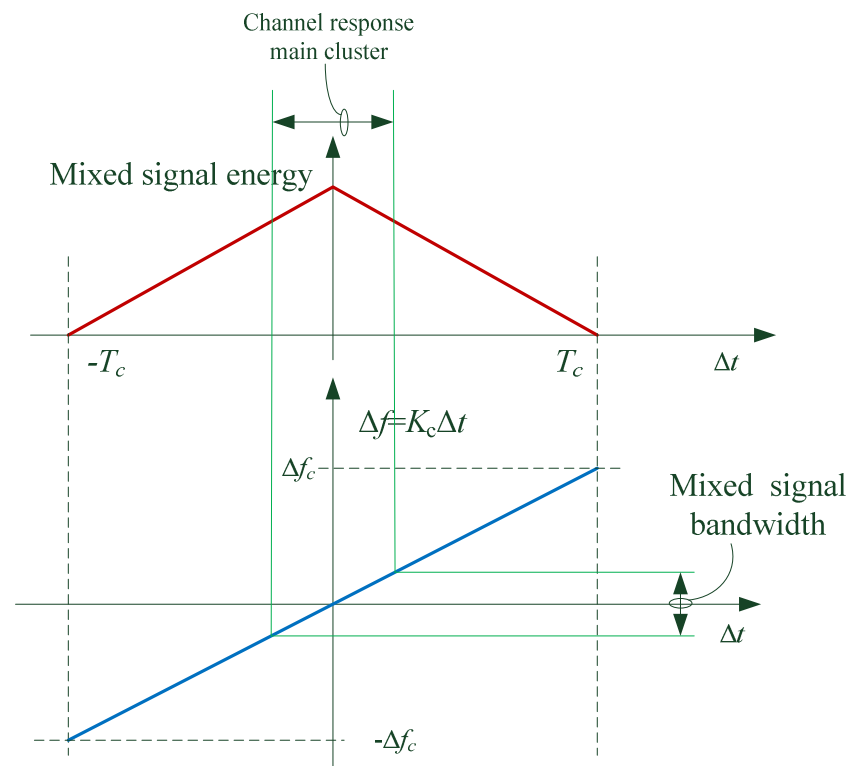
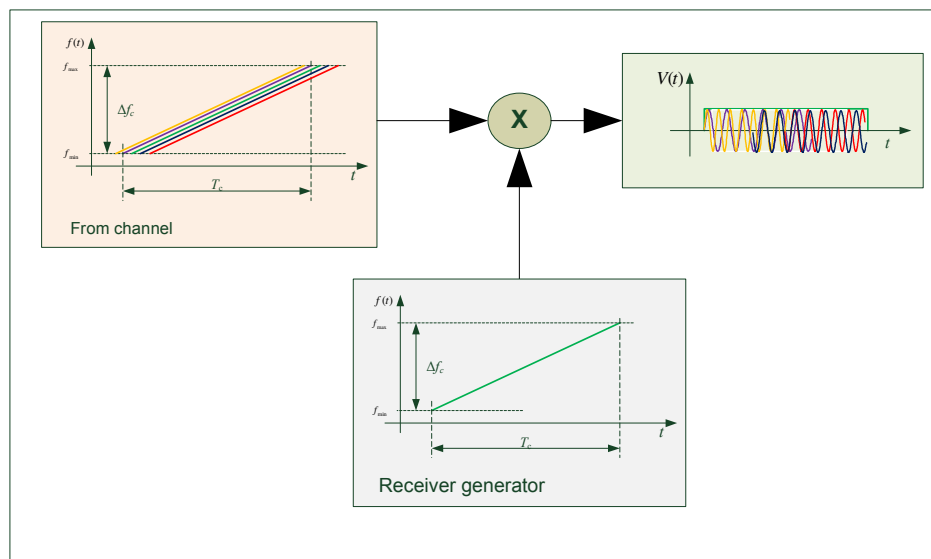

With proper choice of chirp parameters, for a given channel and optimum timing, energy of the multipath signal will be mostly preserved after mixing and concentrated in low frequencies where it can be conveniently sampled.

Chirp pulse generation non-idealities robustness rationale

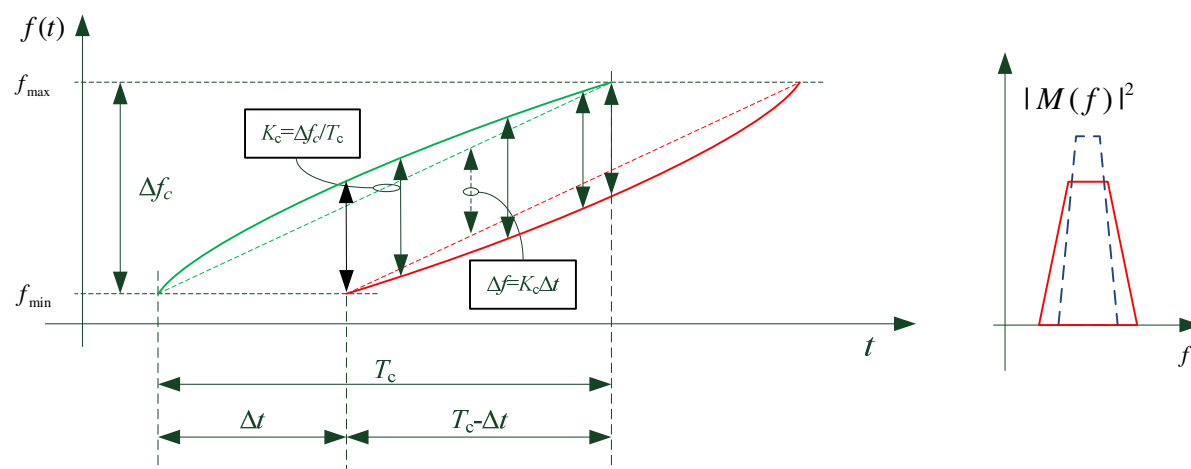

- Non-idealities in chirp generation:
 - Non-linearity and offset in chirp slope (K_c), carrier frequency offset, as well as phase and amplitude modulations encountered in the channel widen the spectra of tones after mixing.
 - There is no need to have very good match in carrier frequency in order to achieve phase coherence.

Timing resolution relaxation rationale

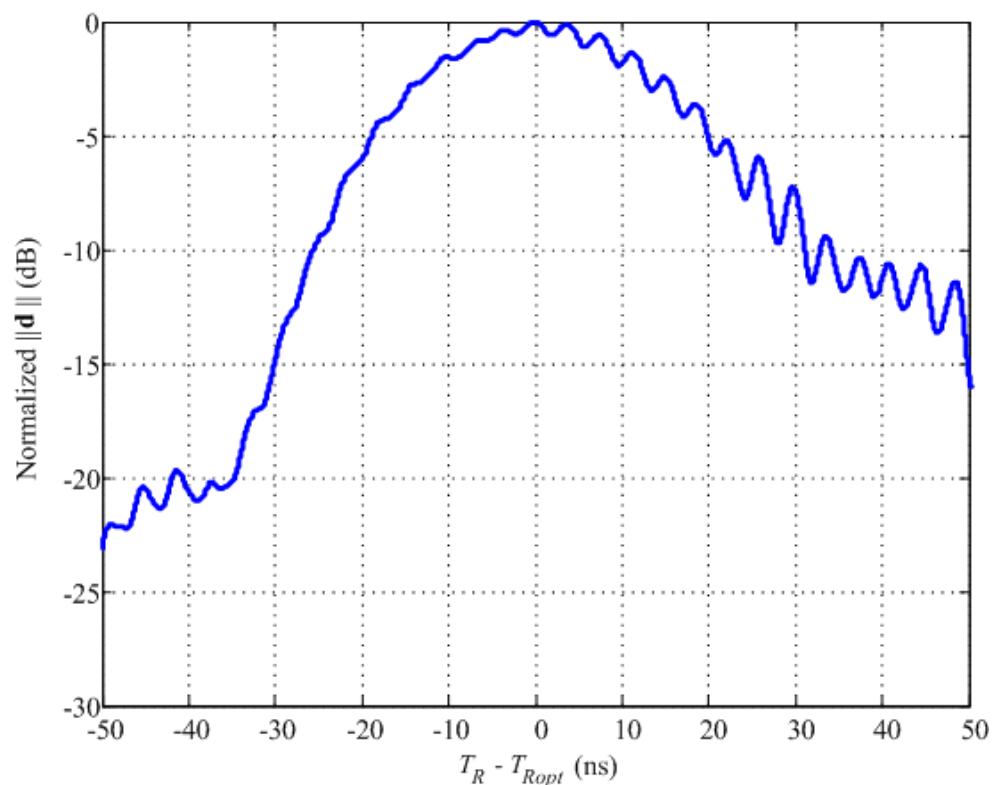

In the worst case scenario (single path), power in the digital portion of the system varies $\sim \Delta T_R / T_c$

In equivalent differentially coherent IR-UWB system with short pulses, power would vary $\sim \Delta f_c \Delta T_R$

Timing resolution necessary is relaxed TB product of the used chirp pulse times.

Duty cycling (power saving) rationale

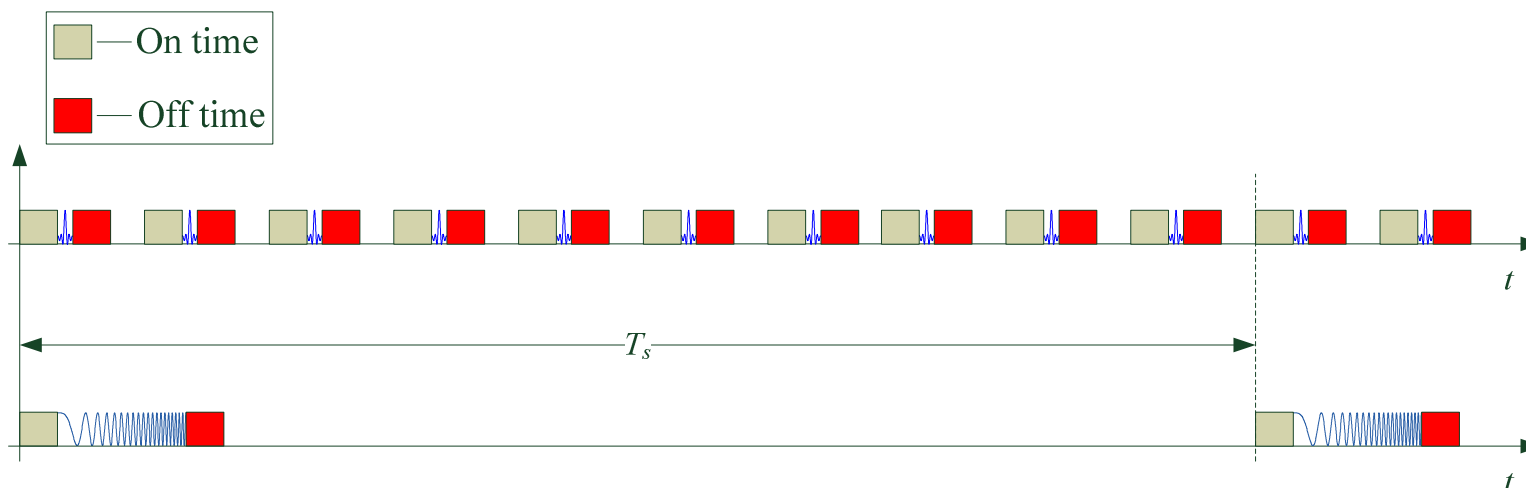

- Duty-cycling is facilitated, both in Tx and Rx, through emitting symbols that consist of single long packet of energy instead of series of isolated short pulses.
- Chirp pulse generator (founded both in Tx and Rx) is inherently duty cycled since it works in pulse regime.
- System is not peak-power limited but RMS power limited, which allows higher EIRP.

System block diagram

- Tx:

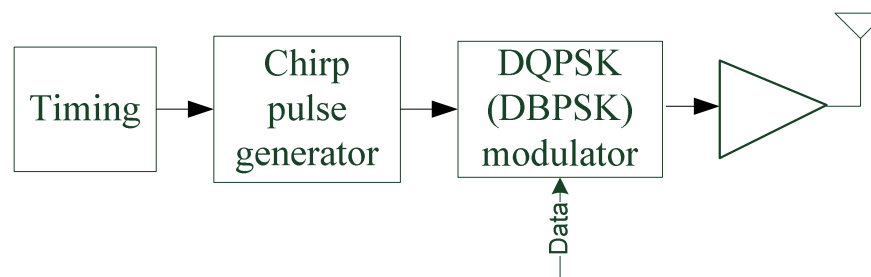

- Rx:

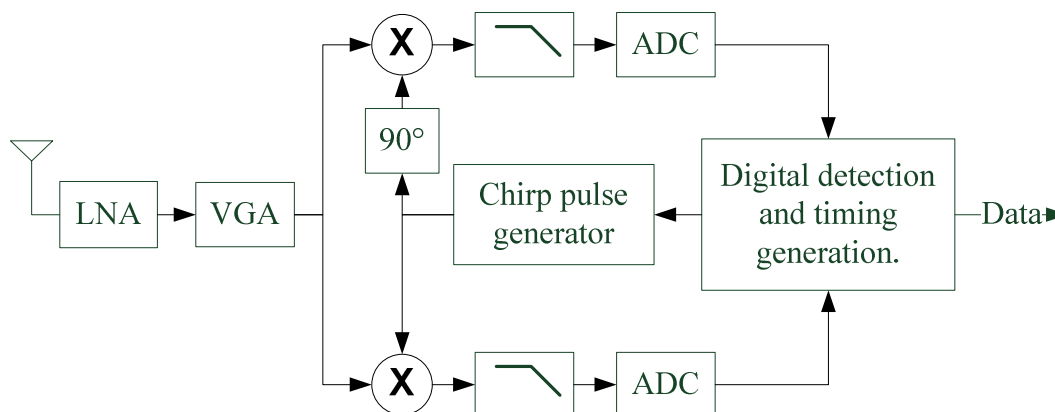

Notes on the system architecture

- System uses differentially phase modulated linear chirp pulses with relatively high TB product as symbols. Each pulse represents one symbol (there are no chips).
- Receiver is Quadrature Analog Correlating (QAC) receiver (in specific configuration) found in both non-coherent and coherent IR-UWB solutions.
- Chirp generator is basically VCO with relatively linear tuning curve that works in pulse regime with linear ramp excitation (This technique of generation of chirp pulses is based on mature UWB VCO technology).

Notes on the system (cont.)

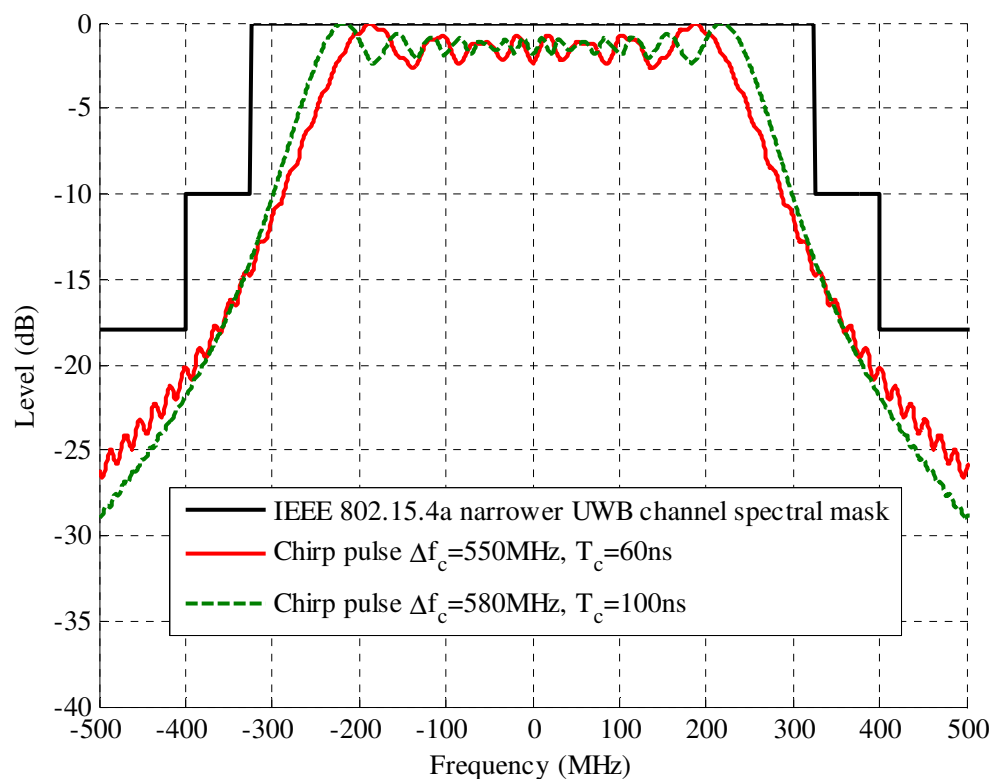

The system uses chirp sweep of 550 MHz in order to fit with high efficiency to narrower IEEE 802.15.4a spectrum mask of about 600 MHz.

Digital detection methods

- There are two symbol detection methods that are considered.
 - 1. Ordinary DPSK detection.** i.e. “Symbol-wise DPSK”.
 - 2. “Digitally Differential Phase Shift Keying (DDPSK)”** i.e. “Sample-wise DPSK”.
(Suboptimal, but does not require any channel vector estimation.)

SYSTEM PERFORMANCE

Quantifying introduced concepts

- System multipath performance regarding chirp pulse duration T_c and number of samples per pulse.
- Effects of the chirp pulse generation non-idealities to the system performance.
- System BER performance with regard to DPSK/DDPSK scheme and sampling resolution used.

System multipath performance IEEE 802.15.6 CM3

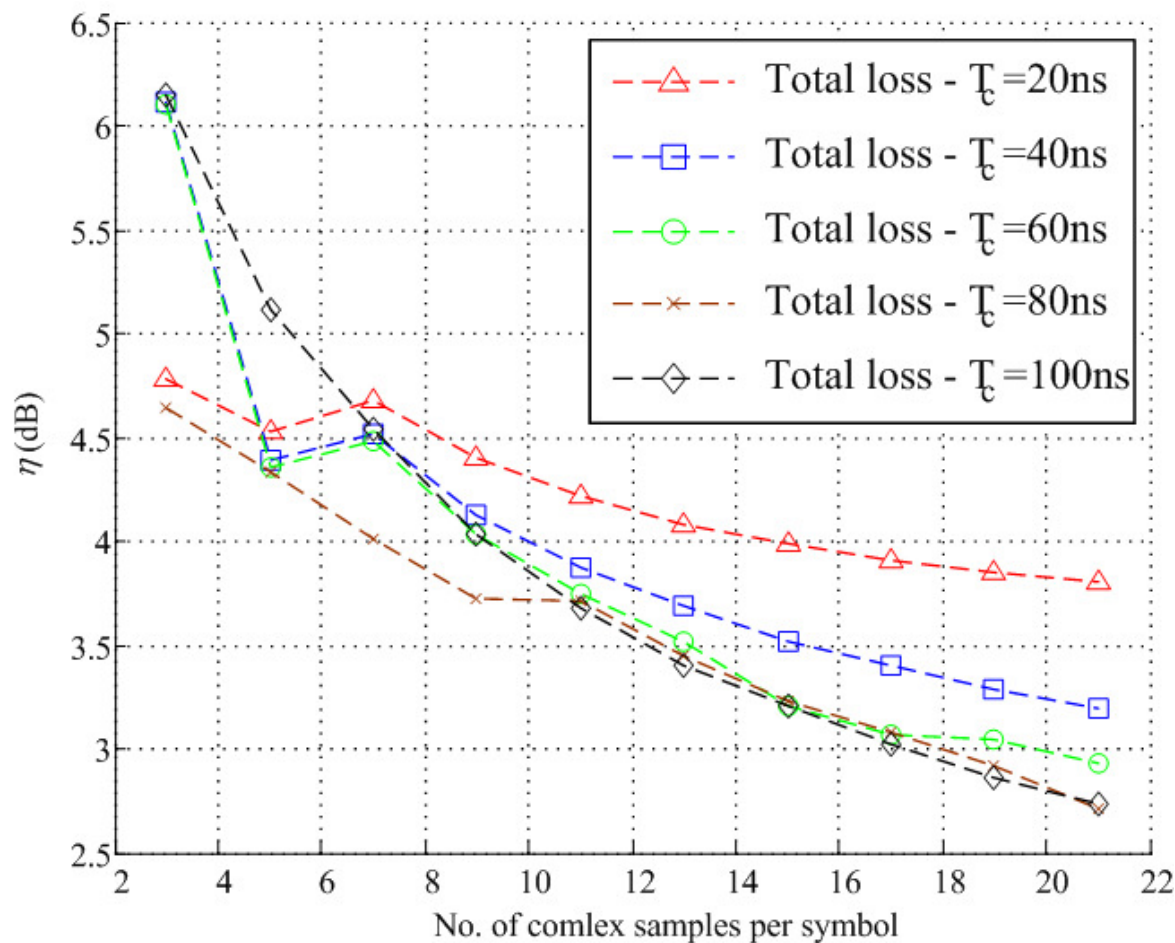

η represents loss of energy compared to ideal (i.e. “full Rake”) receiver that collects all multipath energy.

System multipath performance. (cont.)

IEEE 802.15.6 CM4

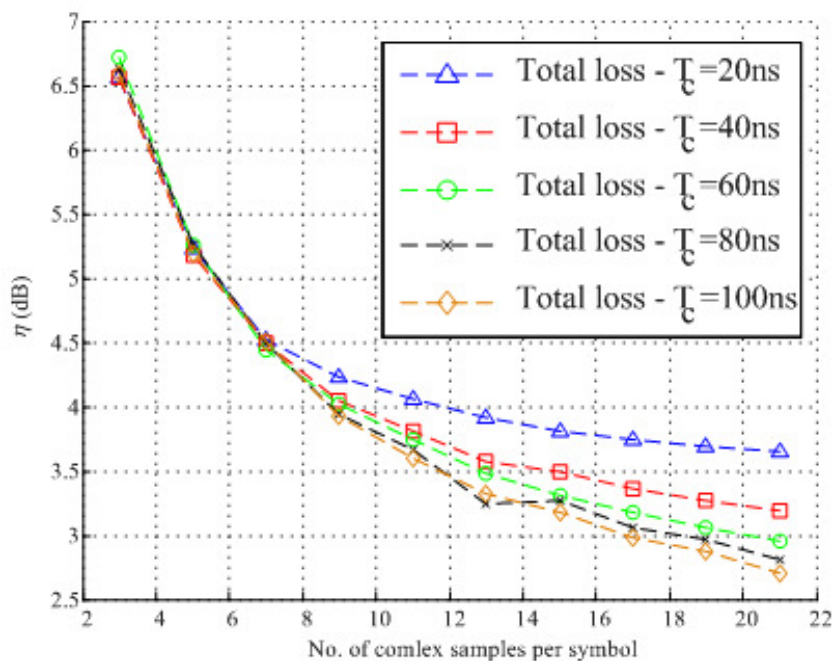

TG6 CM4-1

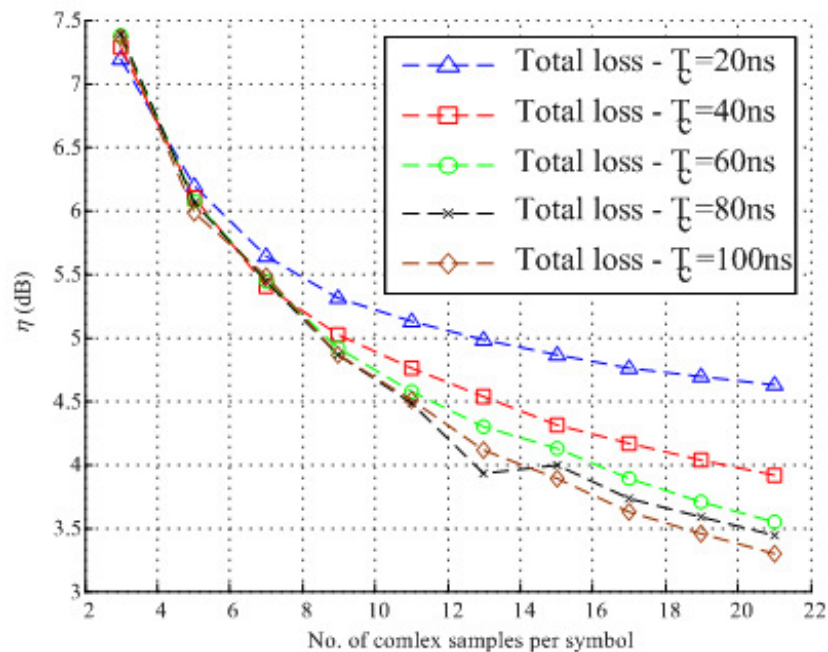

TG6 CM4-2

System multipath performance. (cont.)

IEEE 802.15.6 CM4 (cont.)

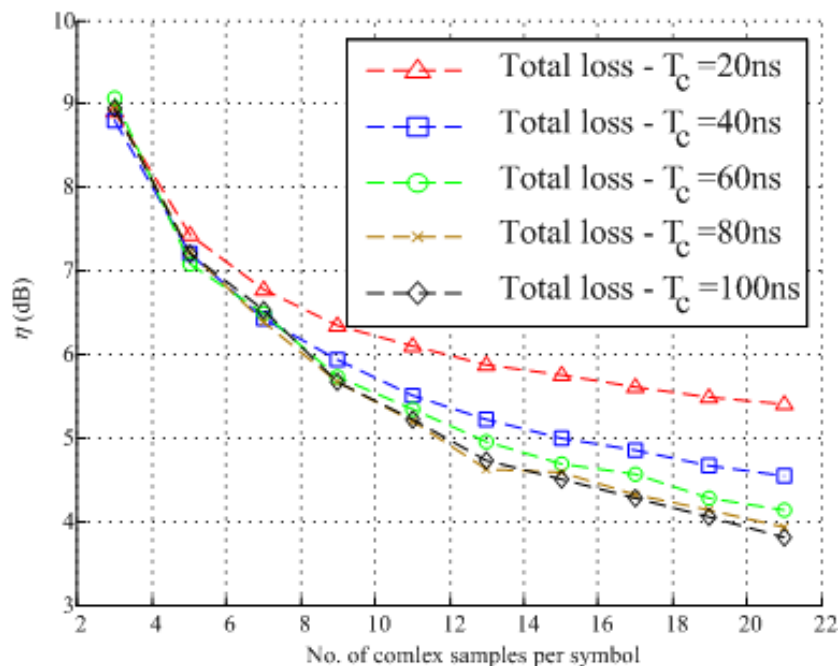

TG6 CM4-3

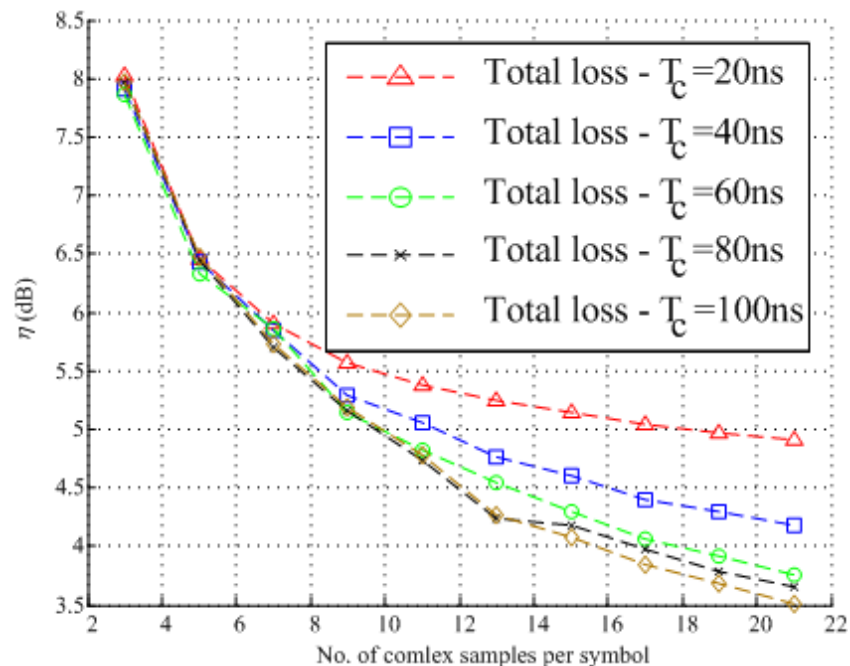

TG6 CM4-4

System multipath performance (cont.) IEEE 802.15.4a Channel Models

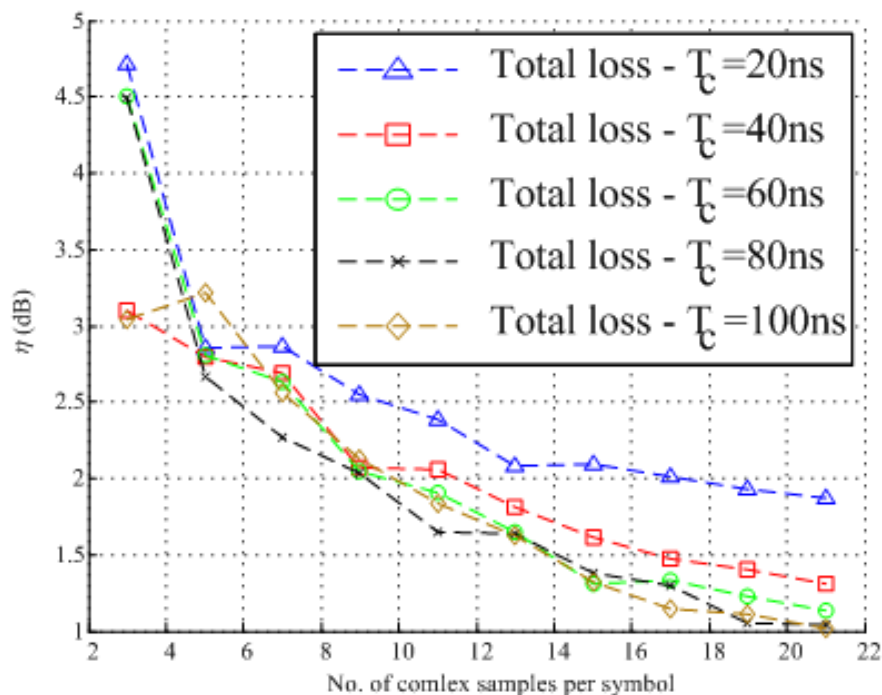

4a CM1

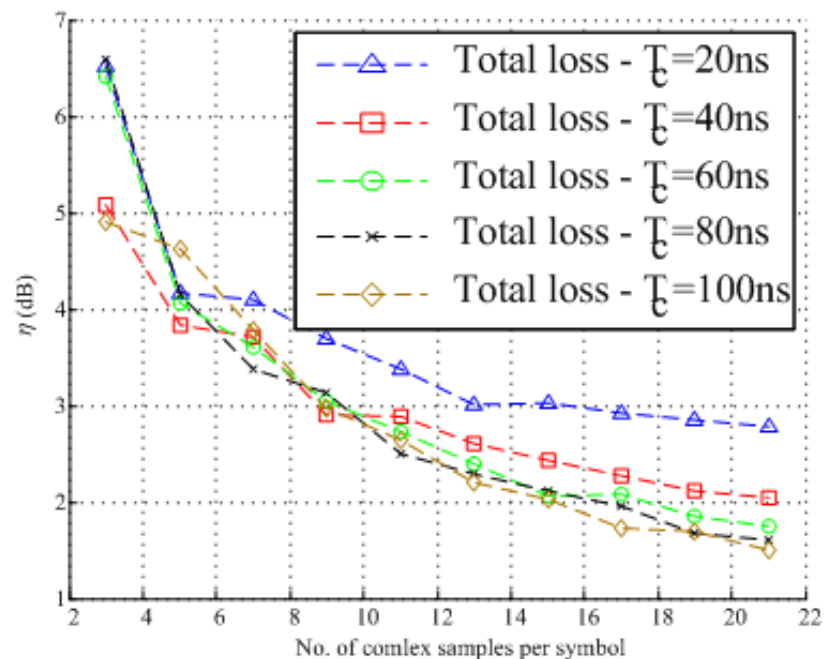

4a CM2

System multipath performance (cont.) IEEE 802.15.4a Channel Models (cont.)

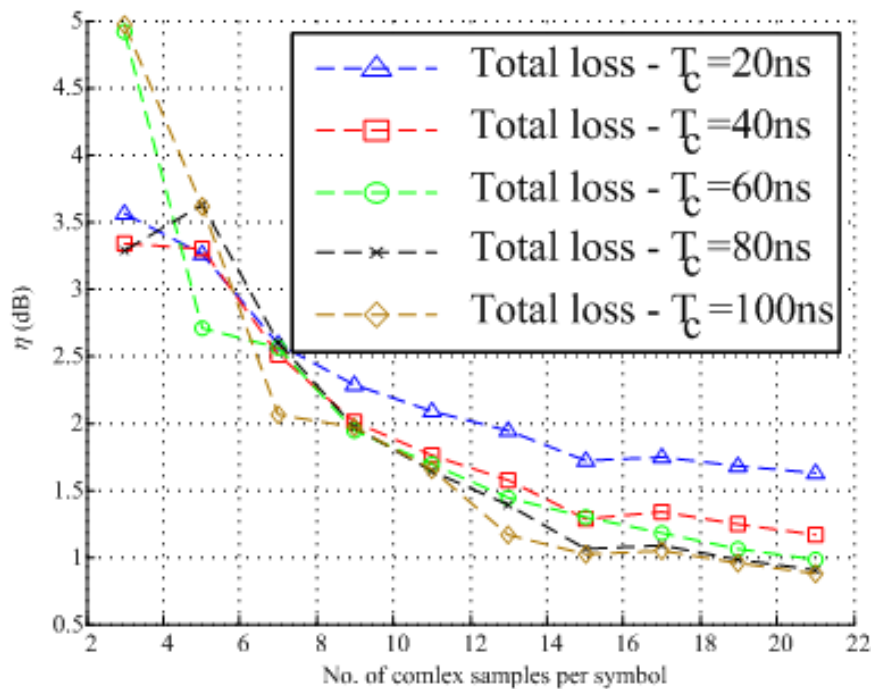

4a CM3

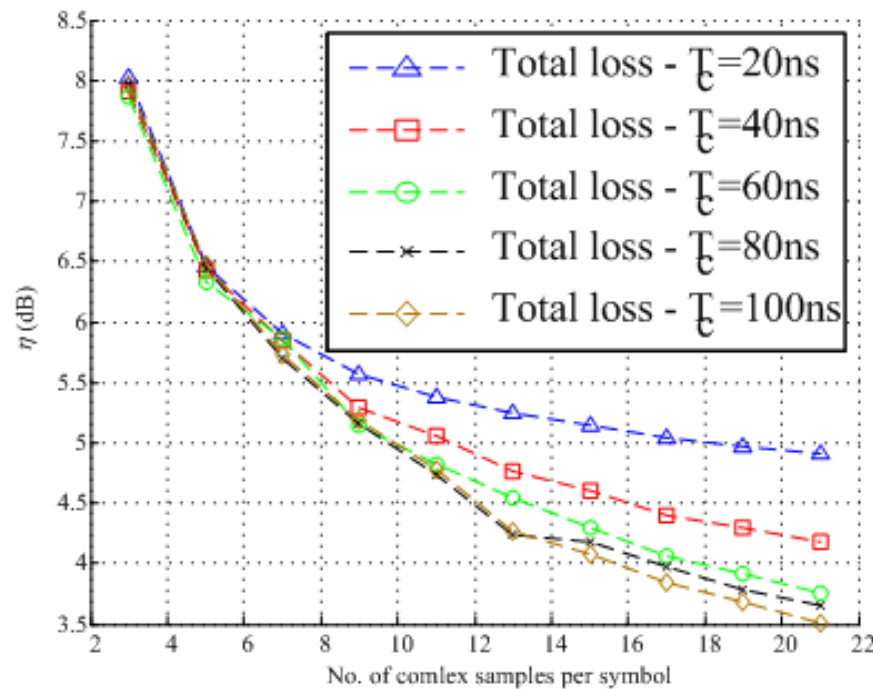

4a CM4

Notes on system multipath performance.

- Chirp duration higher than about 60ns does not significantly improve multipath performance.
- More than about 12 samples per pulse does not improve performance significantly.
- Regarding pulse duration both IEEE 802.15.4a 32ns time slot and its double – 64ns have their advantages.
- 32ns can allow lower duty cycle with some loss in multipath performance (about .5-1.5 dB depending on the channel model and number of samples used).

System robustness to chirp errors

Chirp slope (K_c) error

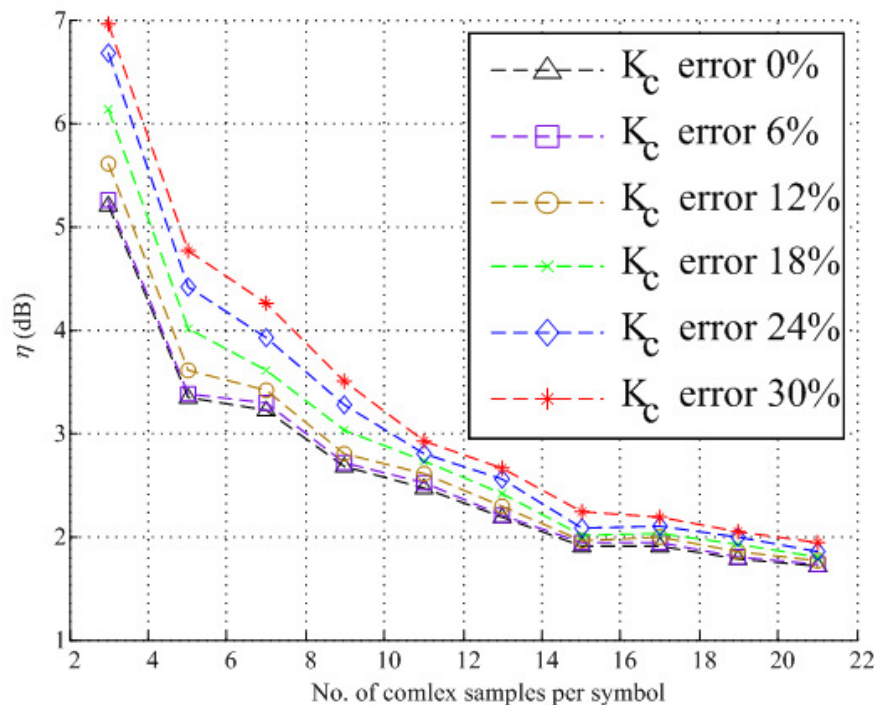

Carrier frequency error

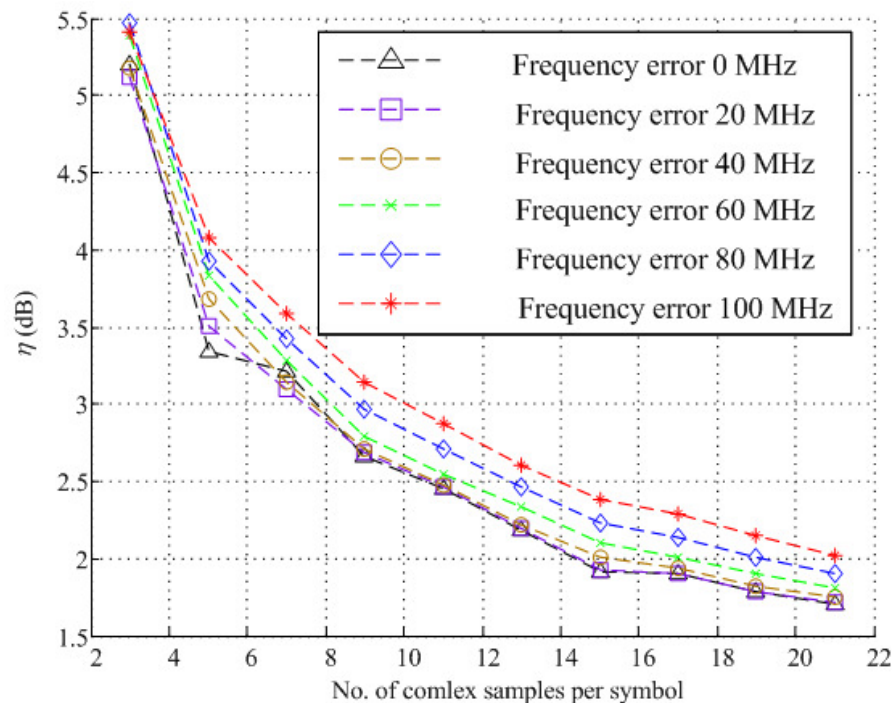

- Chirp slope error of 30% is acceptable
- Central frequency error of 100 MHz is still acceptable.

System robustness to chirp errors (cont.)

K_c non-linearity, same in TX and

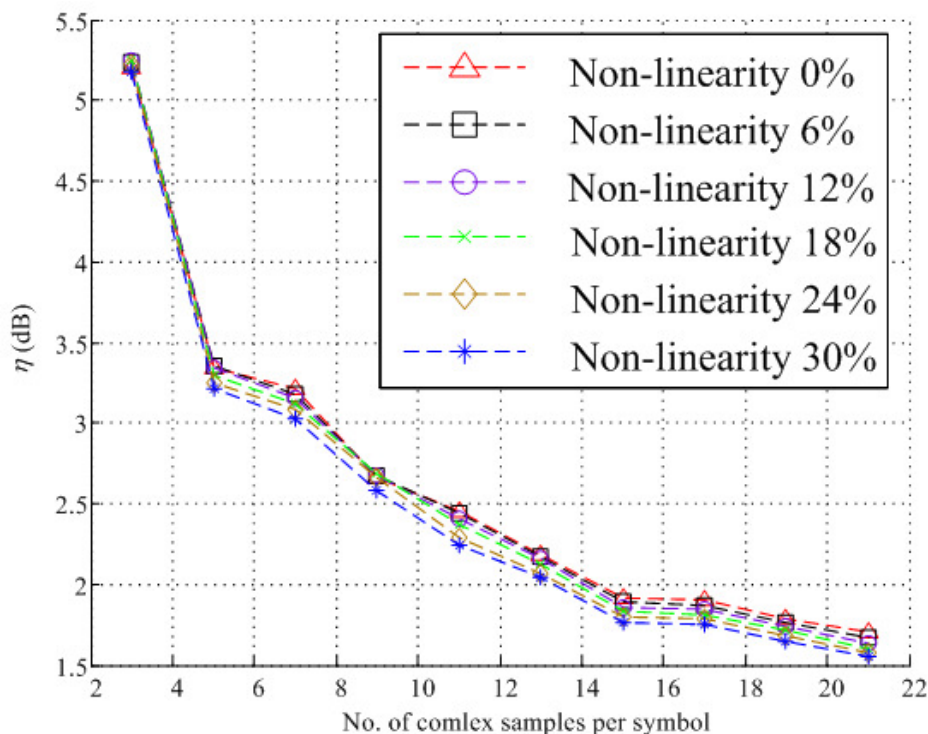

K_c non-linearity, different sign in TX and Rx

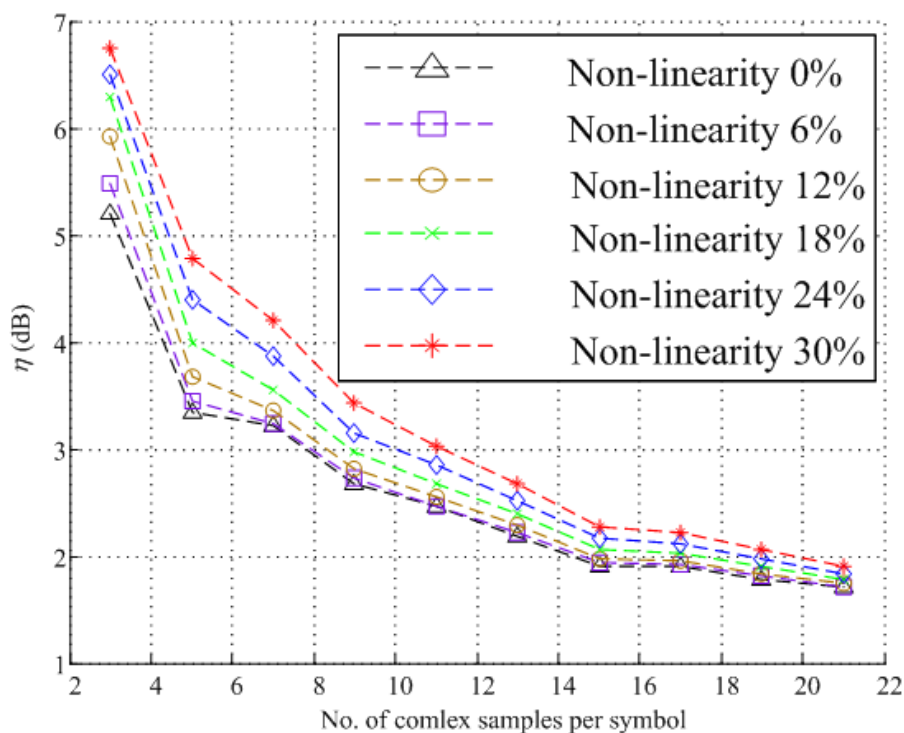

- Non linearity is modeled as 3rd order polynomial.
- 30% Non-linearity is acceptable.

Ordinary DBPSK detection versus DDBPSK with 10 samples per symbol

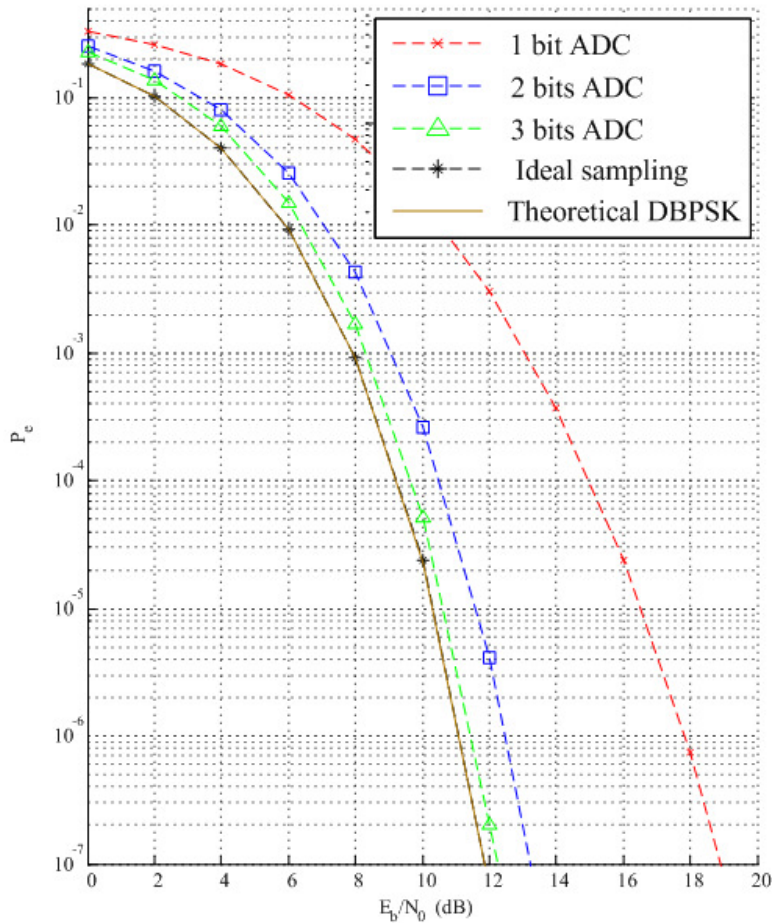

DBPSK

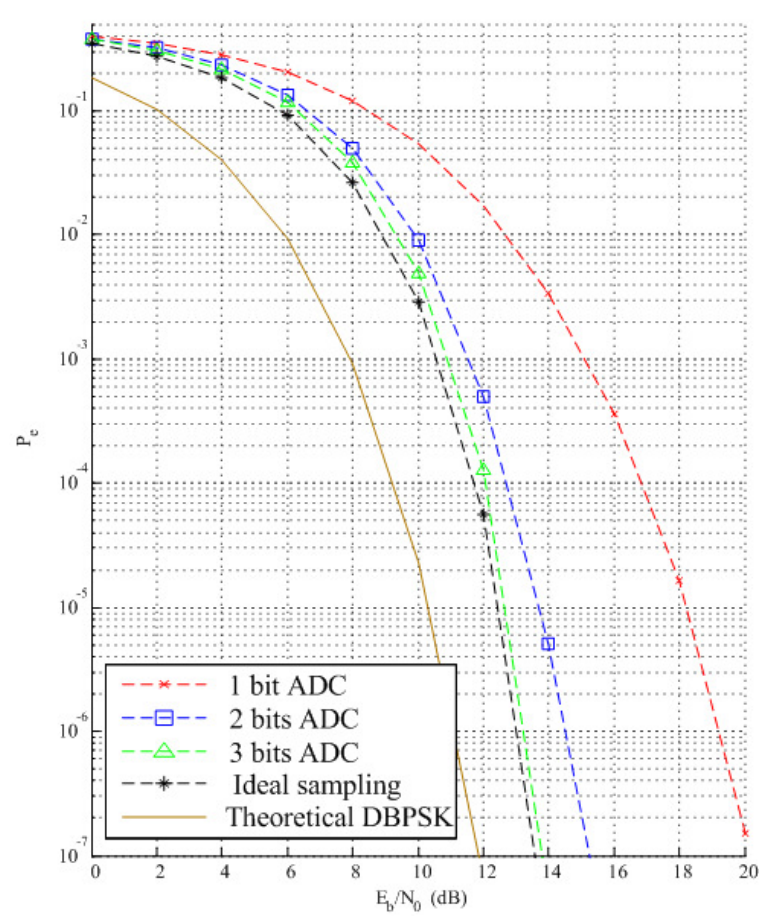

DDBPSK

Ordinary DQPSK detection versus DDQPSK with 10 samples per symbol

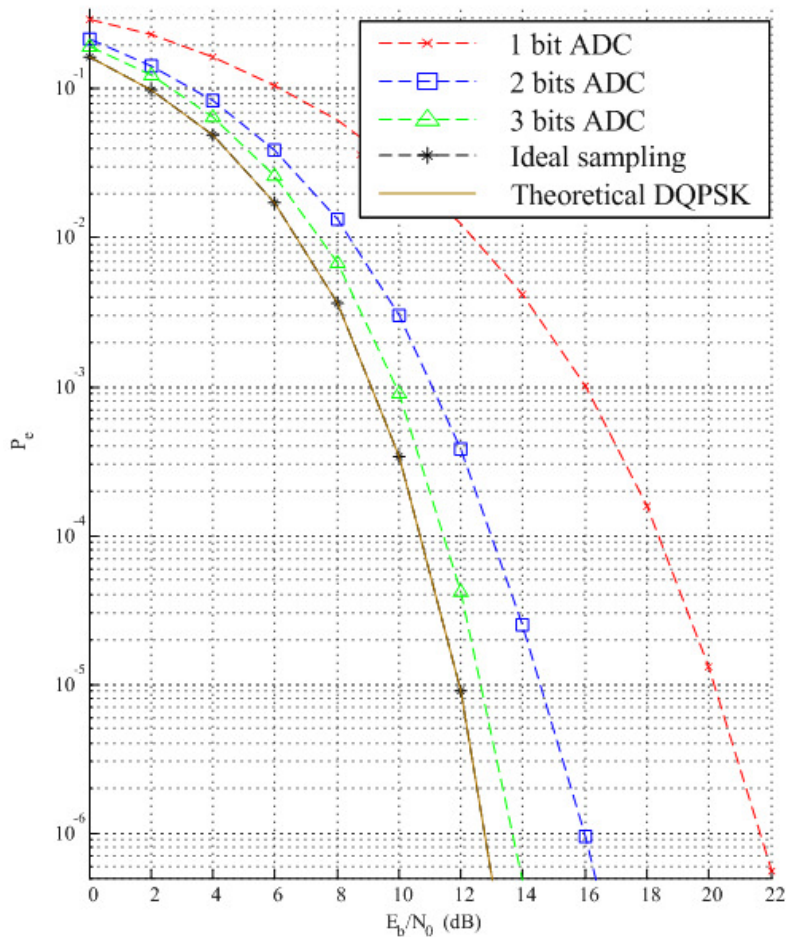

DQPSK

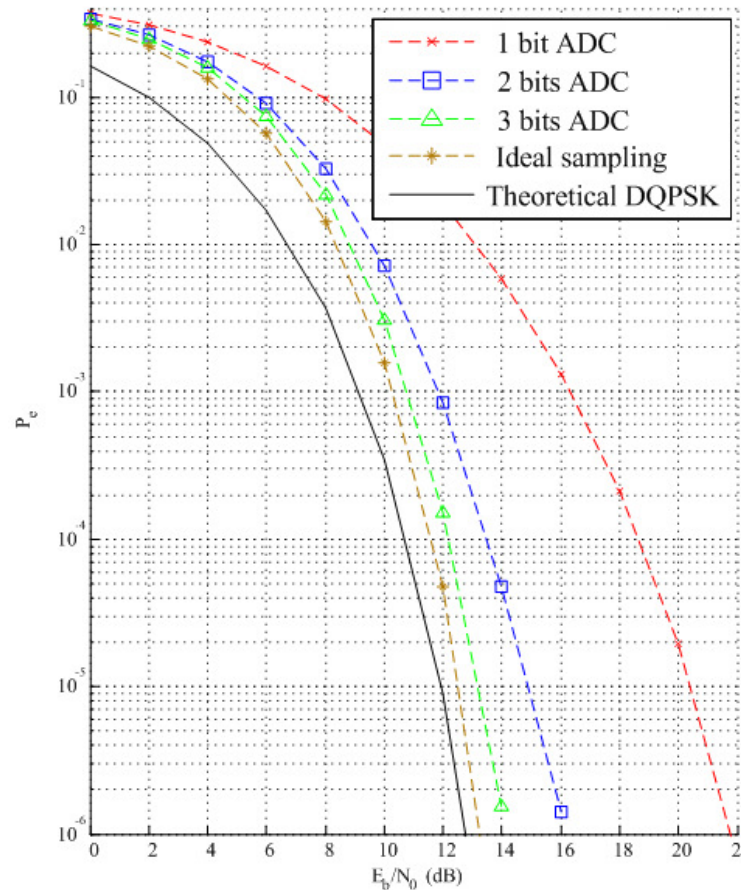

DDQPSK

NBI resistivity of the system regarding sampling resolution.

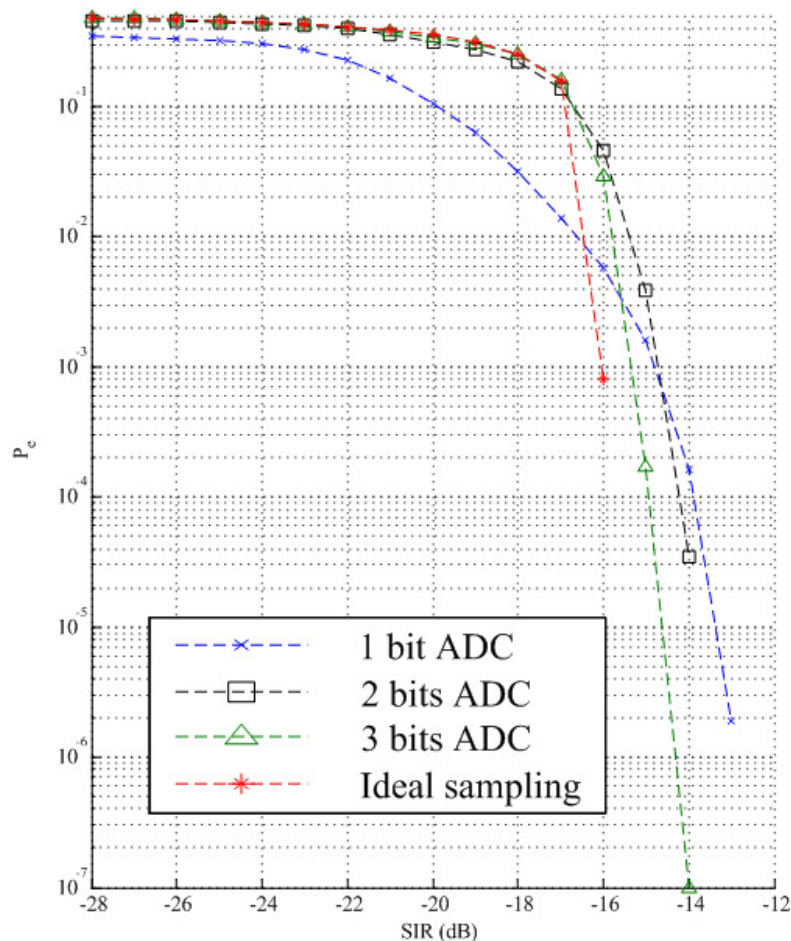

$E_b/N_0=30$ dB, 0.98 Msps (Processing gain 27 dB), DDBPSK

- The system fully utilizes processing gain in NBI resistance.
- The system does not have a problem of saturation of low-resolution ADCs with NBI, like some others do, **2 bits are more than enough here.**
 - Most of processing gain effect to NBI, both in TDMA and CDMA (spreading in frequency and low-pass filtering) is already achieved before ADC.

Comparison to differentially coherent short pulse IR-UWB system

Performance loss	Chirp pulse UWB	Benchmark short pulse IR-UWB
Multipath performance compared to full RAKE (dB)	-1 to -4	-6 to -12
Pulse shape distortion in the channel (dB)	Up to -.5	-3 to -6
Overall performance loss (dB)	-1.5 to -4.5	-9 to -18

- Benchmark short pulse IR-UWB system uses QAC with single sample per chip (pulse).
- It uses single (ideally strongest) multipath component.

Link budget

Factor	Symbol (unit)	Value
Tx power	P_Tx (dBm)	-14
Path Gain 1m (3m)	Pg (dB)	-63 (-58)
Tx antenna gain	G_Tx (dBi)	0
Rx antenna gain	G_Rx (dBi)	0
Multi-path gain	Mp (dB)	-2
Pulse shape degradation	L_pl (dB)	-0.3
Timing jitter	L_jitt (dB)	-0.1
Noise figure	Nf (dB)	7
Noise density	N0 (dBm)	-174
Effective power at detection 1m (3m)	P_det (dBm)	-79.4 (-74.4)
Bit rate	R_b (Mbps)	0.98
Eb/N0 1m (3m)	Eb/N0 (dB)	27.7 (32.7)
Eb/N0 for Pe=1e- 6	Eb/N0_req (dB)	14
Link margin	Lm (dB)	13.7 (18.7)

- For Pe calculation DDBPSK with 2 bit ADC and 10 samples per symbol is used.

- For the same sampling characteristics other modulation/detection methods have +/- 2 dB variation in the link margin.

CONCLUSIONS

Conclusions (cont.)

- Probable proposed system characteristics:
 - For 0.98 Mbps data rate system, we can propose system with T_c of 64 ns and 8 samples per pulse with 1 or 2 bits sampling resolution and DDBPSK.
 - Higher data rates may use T_c either of 32 ns or 64 ns with somewhat more sophisticated digital part of the receiver: e.g. 3 bits of resolution and 12 samples per pulse and DQPSK (There is still wide range of possibilities.)

Conclusions

- The system main advantages are:
 - Multipath performance that is about 1-3 dB lower than one of full Rake receiver.
 - Coherent operation with timing resolution requirement that is close to non-coherent short pulse IR-UWB (can be same as sampling period).
 - Low sampling resolution necessary (2 bits are enough).
 - Low sampling rate (about 10 times symbol rate.)
 - Inherent robustness to error in chirp generation.
- The system is full-blown coherent IR-UWB with:
 - high NBI resistance.
 - high MAI resistance (expected).
 - Other IR-UWB radios interference resistance (expected).
- The system, especially receiver can be easily reconfigured to be used in other IR-UWB schemes.