

Project: IEEE P802.15 Working Group for Wireless Personal Area Networks (WPANs)

Submission Title: [VLC MAC Considerations]

Date Submitted: [11 September, 2008]

Source: [Kang Tae-Gyu, Sang-Kyu Lim, Dae Ho Kim, Kwonhyung Lee, Tae-Wan Kim, Chung Myung-Ae, SungWon Sohn] Company [ETRI]

Address [138 Gajeongno, Yuseong-Gu, Daejeon, Korea]

Voice:[+82-42-860-5232], FAX: [+82-42-860-5611], E-Mail:[tgkang@etri.re.kr]

Re: []

Abstract: [This document presents VLC MAC Considerations]

Purpose: [To PAR/5C discussion on the protocol requirements for VLC PHY/MAC]

Notice: This document has been prepared to assist the IEEE P802.15. It is offered as a basis for discussion and is not binding on the contributing individual(s) or organization(s). The material in this document is subject to change in form and content after further study. The contributor(s) reserve(s) the right to add, amend or withdraw material contained herein.

Release: The contributor acknowledges and accepts that this contribution becomes the property of IEEE and may be made publicly available by P802.15.

VLC MAC considerations

Tae-Gyu Kang
tgkang@etri.re.kr
ETRI

Contents

- VLC Basic considerations
- VLC MAC Interfaces
- VLC MAC considerations

VLC Basic Considerations

- Co-operations with LED illumination
 - Modulation's side effects
- Light Color communication
 - Multi channels
- LED Compatibility
 - LED Interfaces with illumination
- Light Interference Robustness
 - Light interferences among many different lights

VLC Basic Principle

VLC Sending Part

VLC Receiving Part

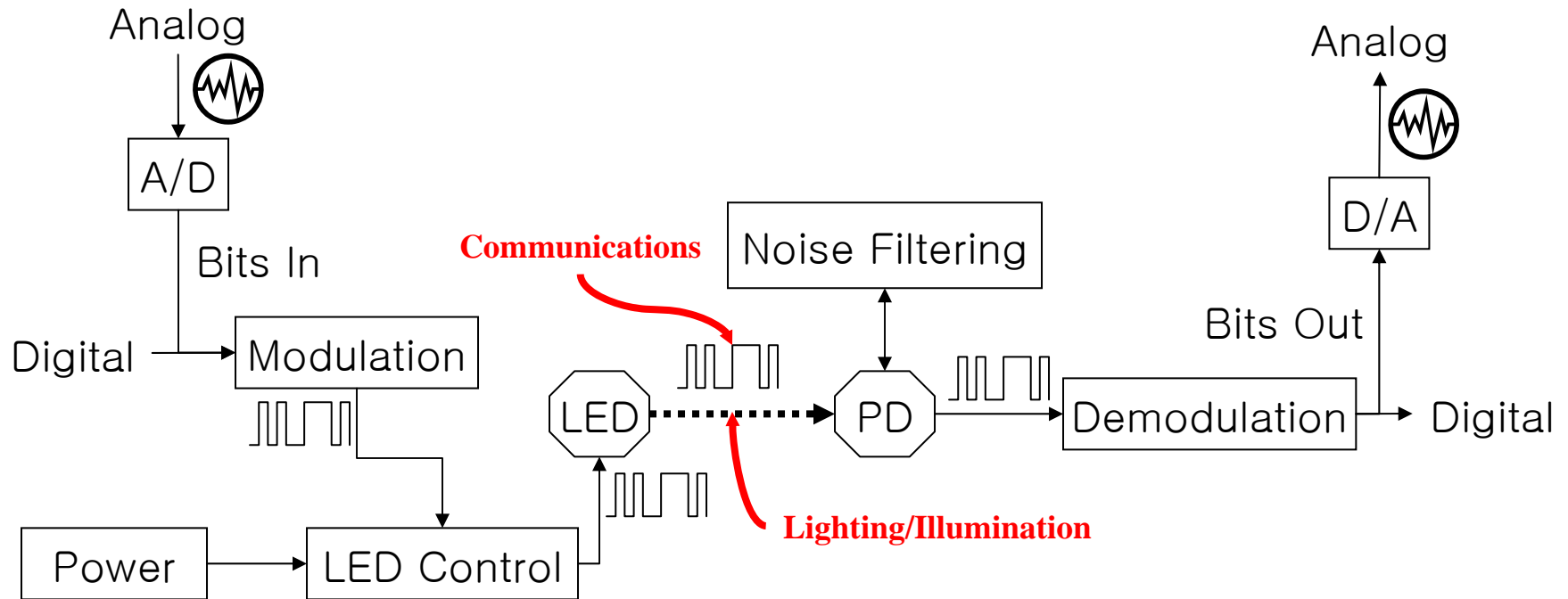

VLC Key Part considerations

- Sending Part
 - LED standard interface
 - Illumination/transmission performance
- Receiving Part
 - PD standard interface
 - Avoidance from any other light interference
- Common Part
 - VLC PHY
 - VLC MAC
 - VLC Architecture

VLC MAC Basic Functions

- MAC PDU format
- MAC header formats
- MAC Management messages
- Error recovery mechanism
- LED illumination management
- VLC Application support mechanism

MAC Requirements

- Distance/Area in terms of light reach/view
 - Long Range
 - Short Range
- Performance
 - Multiple channels
 - One-way/two-way
 - Symmetry/asymmetry speed
- Applications
 - Lighting communications
 - Infrastructure mode/Peer-to-peer mode
 - ITS, LBS, Machine-to-Machine, Sensor, and so on.

VLC MAC Protocol Stack Relations

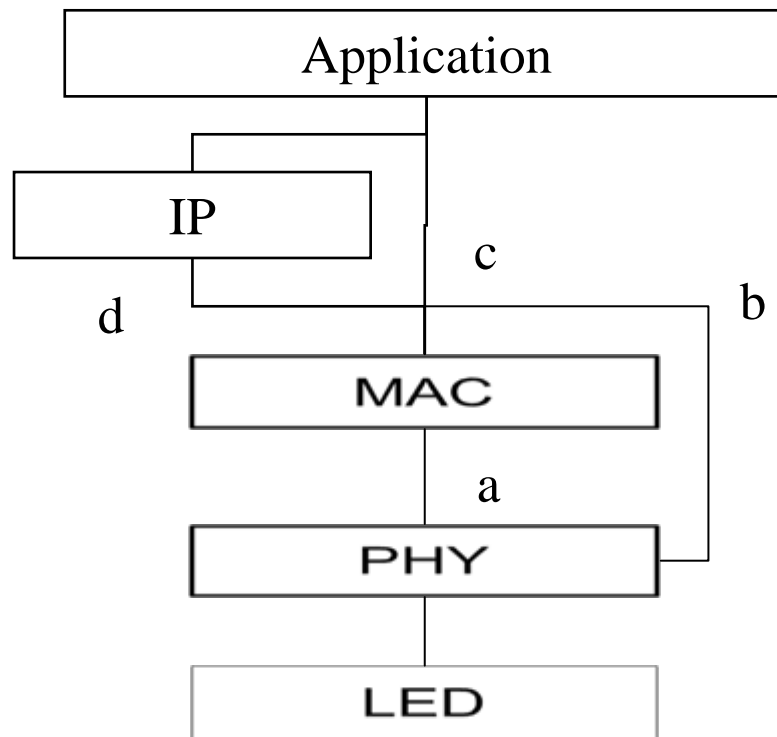

VLC MAC Interfaces

- Interface a
 - MAC-PHY
- Interface b
 - PHY-Application (without MAC)
- Interface c
 - MAC - Application
- Interface d
 - MAC - IP

Interface a

- MAC-PHY interface
 - Media Access Control to Physical Layer
- Functions
 - MAC Addressing mechanism
 - Channel access control mechanism
 - Error recovery
- Applications
 - Services with IP
 - Services without IP

Interface b

- PHY-Application (without MAC)
 - Physical layer to application layer
- Functions
 - straight forward data transfer to application layer
 - Application specific functions
- Applications
 - Simple data transfer without logical channel
 - Analog data transfer

Interface c

- MAC – Application
 - MAC to Application layer
- Functions
 - Handling logical channels
 - Media data transfer without routing
- Applications
 - Stand alone data communication service
 - Machine to Machine service

Interface d

- MAC – IP
 - MAC to IP
- Functions
 - Addressing for routing
 - Media data transfer format for routing
- Applications
 - data communication service with IP
 - End-to-end or client-server service through network

Dimming consideration

- Modulation : Dimming
 - Some modulations make a side effect to the illumination brightness due to off time
- Relationship considerations
 - Speed
 - BER
 - Illumination

Color Considerations

- Channels choice according to a color
 - R(Red)
 - G(Green)
 - B(Blue)
- Color Spectrum Standard
 - Boundary: From – to
- Color channel management

Light Interference Consideration

- Light noises
 - Sun light
 - Illumination from others
 - Reflection light
- Considerations
 - Noise Echo Cancellation
 - Avoid noise

Error Recovery Consideration

- Errors
 - Long distance
 - Fog/heavy rain
 - Obstacle Swing
- Considerations
 - Strong Error Recovery function
 - No Error Recovery function

Conclusions : VLC MAC features

- Color communication
 - Color channel handling service
 - SIMO, MISO, MIMO
 - Channel status as same as illumination status
- LED Compatibility
 - LED Interfaces with illumination
 - Dimming considerations
- Light Interference Robustness
 - Light interferences among many different lights
 - Error Recovery mechanism