

Project: IEEE P802.15 Working Group for Wireless Personal Area Networks (WPANs)

Submission Title: [The Protocol Requirements for VLC PHY/MAC]

Date Submitted: [17 July 2008]

Source: [Kang Tae-Gyu, Sang-Kyu Lim, Dae Ho Kim, Kwonhyung Lee, Tae-Wan Kim, Chung Myung-Ae] Company [ETRI]

Address [138 Gajeongno, Yuseong-Gu, Daejeon, Korea]

Voice:[+82-42-860-5232], FAX: [+82-42-860-5611], E-Mail:[tgkang@etri.re.kr]

Re: []

Abstract: [This document presents key requirements for the protocols of VLC PHY/MAC]

Purpose: [To PAR/5C discussion on the protocol requirements for VLC PHY/MAC]

Notice: This document has been prepared to assist the IEEE P802.15. It is offered as a basis for discussion and is not binding on the contributing individual(s) or organization(s). The material in this document is subject to change in form and content after further study. The contributor(s) reserve(s) the right to add, amend or withdraw material contained herein.

Release: The contributor acknowledges and accepts that this contribution becomes the property of IEEE and may be made publicly available by P802.15.

The Protocol Requirements for VLC PHY/MAC

Tae-Gyu Kang
tgkang@etri.re.kr
ETRI

VLC Basic Principle

VLC Sending Part

VLC Receiving Part

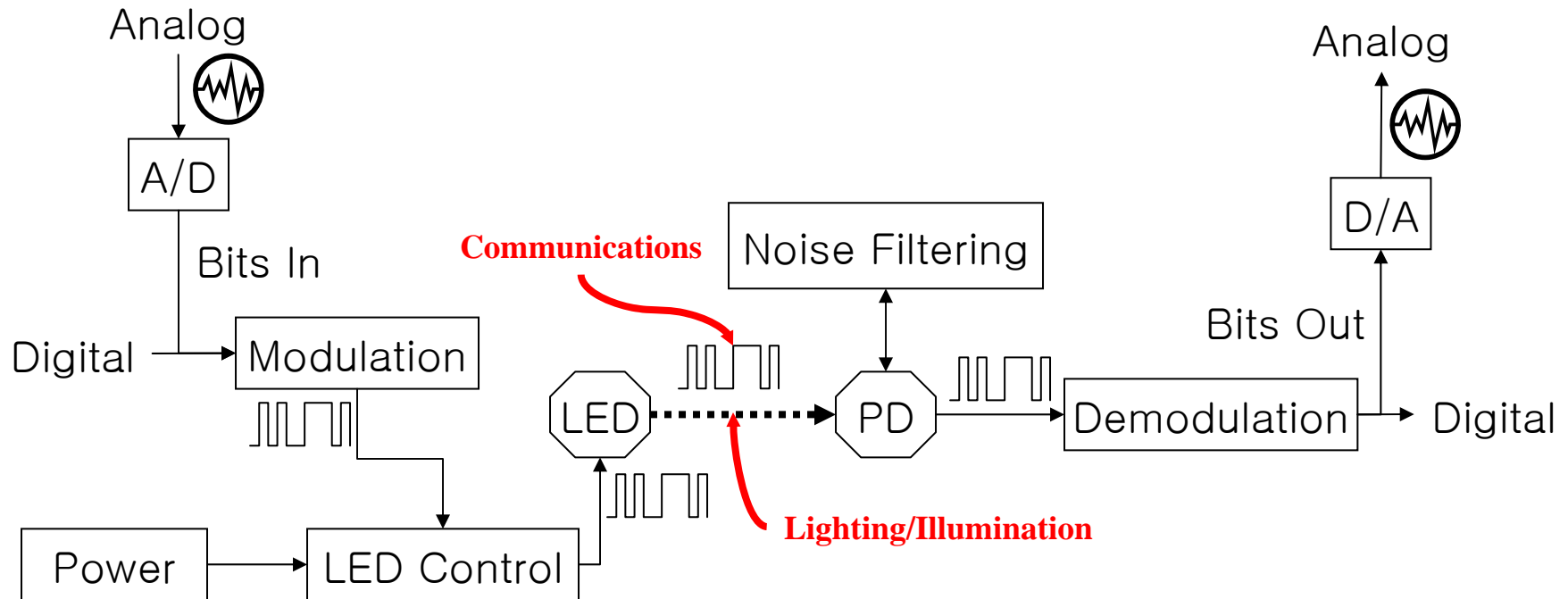

VLC Key Standard Parts

- Sending Part
 - LED standard interface
 - Illumination/transmission performance
- Receiving Part
 - PD standard interface
 - Avoidance from any other light interference
- Common Part
 - VLC PHY and MAC
 - VLC Architecture

Key Factors for VLC PHY/MAC

- Key different characteristics
 - Co-operations with LED illumination
 - Light Color communication
- VLC PHY/MAC
 - LED Compatibility
 - LED Interfaces with illumination
 - Light Interference Robustness
 - Light interferences among many different lights

Applicable Wavelengths: 380 - 780

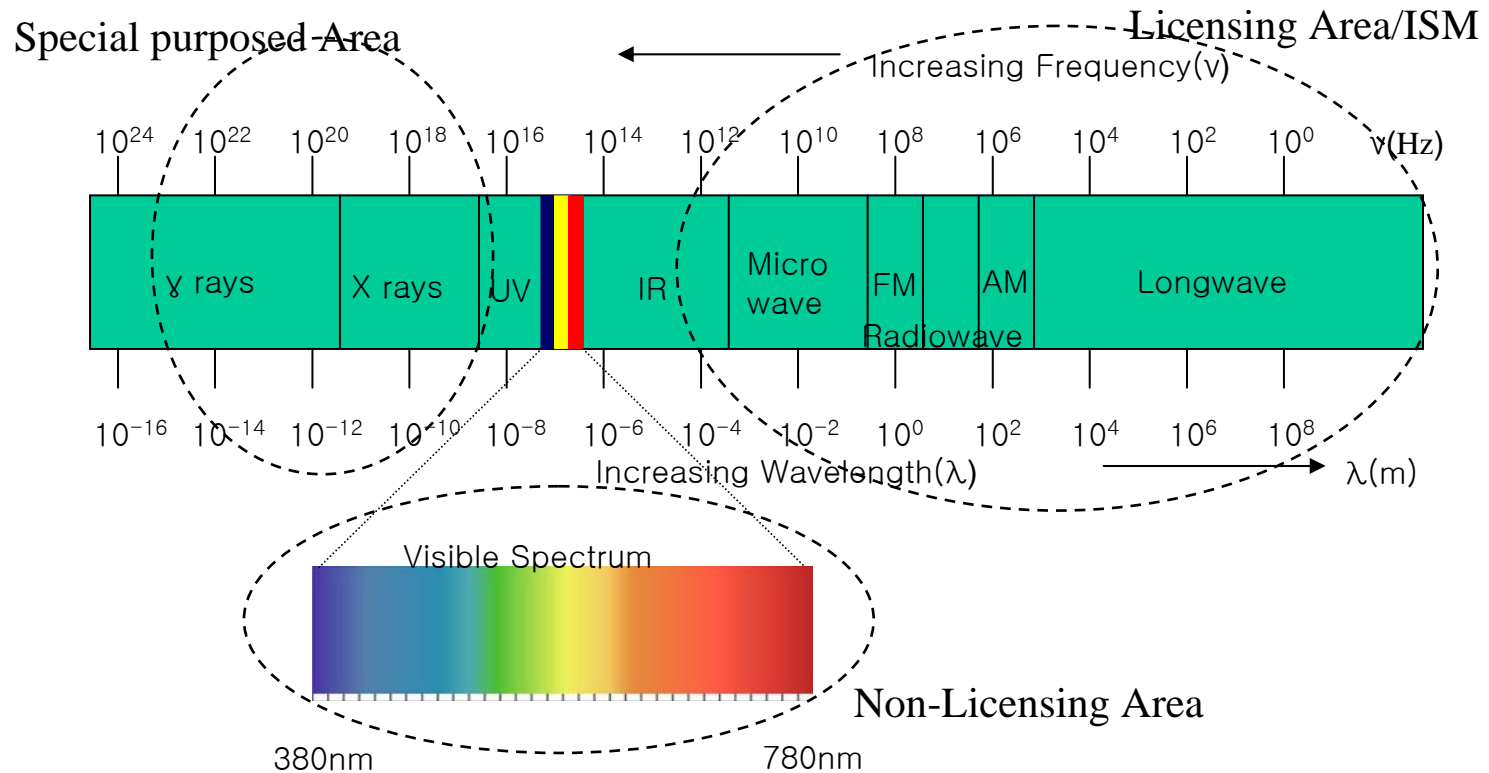

Visible Light Communications should be used visible light: The wavelength covers from 380 to 780.

Candidates for VLC MAC on VLC email

- 802.15.4a for long range (still on going)
- 802.15.3a for short range (aborted)
 - that it could be very difficult to cover all the VLC applications with one MAC, or it will become inefficient.
- New MAC for VLC
 - LED Lighting Communications

MAC Requirements for VLC applications

- Distance
 - Long Range Low speed
 - Short Range High speed
- Performance
 - Multiple channels
 - One-way/two-way
 - Symmetry/asymmetry speed
- Applications
 - Lighting communications
 - Infrastructure mode/Peer-to-peer mode
 - ITS, LBS, Machine-to-Machine, Sensor, and so on.

VLC Application Areas

- Inter Mobile handsets
 - Mobile handset, MP3, Notebook
- LED Display to handset
 - Handset, TV, Signboard
- Inter Vehicles
 - Taillight, Headlight, On-and-off light
- Lamp applications
 - Indoor illumination, Traffic signal, Route beacon

5 Requirements for VLC PHY/MAC

- Visible Light Wavelength
- Compatibility Lighting System
- Wide Applicable Area
- Technical Feasibility
- Different Application Service

Visible Light Wavelength

- Wavelength Scope
 - 380 – 780 nm
- Color communication
 - Different information depending on color
 - Choice, verify
- LOS (Line of Sight)
 - Safe communication due to no transparency

Compatibility Lighting System

- Share lighting system
 - Lighting and communication as same time
Concurrently
 - Sustainable lighting function
- Compatibility LED Interface
 - Same standard interface for lighting and communications

Wide Applicable Area

- Everywhere
 - Any place using LED lighting Infrastructure
- Any field
 - Car lamp, traffic signal, light house, signboard, and so on
- Different capabilities
 - Short, long, bright, dimming

Technical Feasibility

- Same lighting source
 - Both lighting and communication
- Digital control
 - Programmable the lighting
- Fast switching on/off
 - 10 – 200 nm switching

Different Application Service

- Digital communication
 - Sending and receiving
- LBS
 - Useful for Location Based Service
- Restricted Area Broadcasting
 - Providing information depending on area
- Advance Sensing
 - LOS sensing with digital information

Conclusion : VLC PAR/5C Considerations

- Object
 - Developing Visible Light Communication PHY/MAC
 - Wavelength 380 to 780nm
- Scope
 - VLC PHY
 - VLC MAC
- Functions
 - Lighting Communication with one lighting
 - Light Interference Robustness
 - Compatibility for LED/PD Interfaces
 - Features for different application services