

Project: IEEE P802.15 Working Group for Wireless Personal Area Networks (WPANs)

Submission Title: [Resolutions for the new comments received before May 9]

Date Submitted: [May 14, 2008]

Source: [Ryuhei Funada¹, M. Azizur Rahman¹, Fumihide Kojima¹, Chin-Sean Sum¹, Tuncer Baykas¹, Pyo Chang-Woo¹, Zhou Lan¹, junyi Wang¹, Hiroshi Harada¹, Masahiro Umehira¹, Shuzo Kato¹, Hirokazu Sawada²]

Company [¹National Institute of Information and Communications Technology (NICT), ²Tohoku Institute of Technology]

Address¹[3-4 Hikari-no-oka, Yokosuka-shi, Kanagawa 239-0847, Japan]

Voice¹:[+81-46-847-5074] , FAX¹: [+81-46-847-5440]

E-Mail¹:[funada@nict.go.jp, aziz@nict.go.jp, f-kojima@nict.go.jp, sum@nict.go.jp, tuncerbaykas@nict.go.jp, junyi.wang@nict.go.jp, cwpyo@nict.go.jp, lan@nict.go.jp, umehira@mx.ibakaki.ac.jp, harada@nict.go.jp, shu.kato@nict.go.jp]

Address²[35-1, Kasumi-cho, Yagiyama, Taihaku-ku, Sendai-shi, Miyagi 982-8577, Japan]

Voice²:[+81-22-305-3438], FAX²: [+81-22-305-3402], E-Mail²:[sawahiro@tohtech.ac.jp]

Re: [In response to]

Abstract: [Resolutions for the new comments received before May 9 are shown.]

Purpose: [To be considered in TG3C baseline document.]

Notice: This document has been prepared to assist the IEEE P802.15. It is offered as a basis for discussion and is not binding on the contributing individual(s) or organization(s). The material in this document is subject to change in form and content after further study. The contributor(s) reserve(s) the right to add, amend or withdraw material contained herein.

Release: The contributors acknowledge and accept that this contribution becomes the property of IEEE and may be made publicly available by P802.15.

Resolutions for the new comments received before May 9

NICT

14/05/2008

Summary

- Total number of the new comments received before May 9 is **26**.
- **This document presents only SC comment resolutions**
 - :16 out of 26 resolutions
- SC : **16**
 - :PHY:14, MAC: 1, beamforming:1**
- HSI OFDM: 10
- AV-OFDM:0

Comment 1 (beamforming)

- Provide an alternate means to feedback the beamforming response. In the current text, an index to a beamforming vector is communicated. The alternate method should allow to feedback explicitly the transmit beamforming vector. This provides significant improvement in multipath scenarios.
- Resolution: Will be resolved in Beamforming

Comment 2 (SC PHY, document modification)

- There are 4 possible PW lengths, how to signal this info in PHY header?
- HZ proposal: Use 2 bits to specify PW lengths.
- Resolution: The PW length ID field shall specify the type of PW length used in the current frame, as defined in the following table.

PW length ID	Length
00	0
01	16
10	32
11	64

Comment 3 (SC PHY, editorial)

- Here the spec mentions "with an option to substitute PW with CP", but CP is SC mode is not specified in DF3 at all, it was removed in DF3 .
- HZ proposal: remove this sentence
- Resolution: Accept the comment. This sentence shall be removed from the draft.

Comment 4 (SC PHY, document modification)

- The description on $\pi/2$ BPSK and $\pi/2$ QPSK is unclear, better to give math expressions. Also, is the rotation initiated from 1 or j ? Current text can have multiple interpretations.
- HZ proposal: Clarify
- Resolution: Same as comment #66 in 15-08-0322-01-3c (May 13th).

Comment 5 (SC PHY, document change)

- Figure 189, more description in terms of equations is required to equate $\pi/2$ BPSK modulator and GMSK modulator. For example initial phase of the chip level rotator. Also, the differential operation (xor) as currently specified is incorrect. If g_n is the input to the GMSK modulator then in the real field $g_n = d_n \times d_{(n-1)}$ which is inverse of xor. In general, complete specification through equations would help rule out ambiguity
- Resolution: Accept the comment partially. Equations shown in the next slide shall be added to equate $\pi/2$ BPSK modulator and GMSK modulator. Figure 189 shall be replaced as shown in the next slide.

Document modification and addition

To be added

the following equations shall be added for pi/2 BPSK in 12.2.2.1.1

$$c_n = \begin{cases} 1, & \text{if } d_n = 1 \\ -1, & \text{if } d_n = 0 \end{cases}$$

$$b_n = c_n e^{jn\frac{\pi}{2}}, n = 0, 1, 2, \dots$$

The following equations shall be added for precoded GMSK in 12.2.2.1.3

$$c_n = d_{n-1} \otimes d_n$$

$$b_n = b_{n-1} \cdot e^{-j \cdot c_n}, n = 0, 1, 2, \dots$$

$$d_0 = 1, b_0 = e^{-j}$$

To be modified

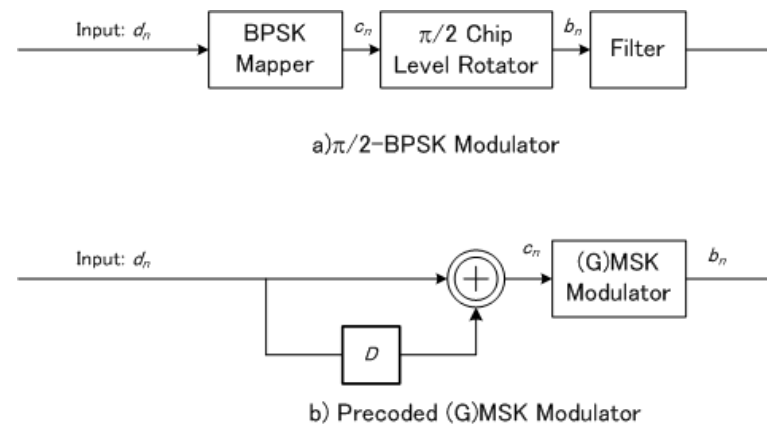

Figure 189

Comment 6 (SC PHY, no change)

- Would be useful in general to describe all the modulations precisely through equations. Current text has multiple interpretations.
- Resolution: Resolved as stated in 15-08-0322-01-3c and in Comment #5 regarding $\pi/2$ BPSK, $\pi/2$ QPSK, and GMSK. DAMI has already modified in 15-08-0311-00. The others are clearly stated.

Comment 7 (SC PHY, no change)

- What are the settings on D and W on generating the Golay codes specified in DF3?
- HZ proposal: Give D and W for all the Golays codes provided in the draft spec.
- Resolution: Reject the comment. Golay code sequences are already specified in the baseline document (p85, p86, p134, p135, and p136 (for SC)). D and W values are not required.

Comment 8 (SC PHY, document modification)

- In step b) of line 23, "format the frame header into bursts", is PW inserted in each burst in header? If yes, how to specify the PW length of the header. If No, clearly state that PW length=0 for header.
- HZ proposal: as in comment
- Resolution: The sentence: "With the exception of the base rate, the default pilot word length for the header shall be 64 chips for a burst length of 256 chips" in 12.2.1.2 (header rate dependent parameters) shall be replaced by the sentence:
"PW with length of 0 shall be used for CR, and PW with length of 64 shall be used in the other cases".

Comment 9 (SC PHY, editorial)

- In Fig 199, Burst builder is before mapper, while in Fig207 (Payload), Burst builder is after mapper.
- HZ proposal: unify, move burst build after mapper
- Resolution: Accept the comment. Fig 199 shall be changed to keep consistency with Fig 207.

Comment 10 (SC PHY, editorial)

- What does step c) mean? Preamble and PCES are not related to header
- HZ proposal: remove step c).
- Resolution: Accept the comment. The description of “step c)” shall be removed.

Comment 11 (SC PHY, document addition)

- For payload construction procedure, should PW and PCES also modulated using $\pi/2$ BPSK before their insertions?
- HZ proposal: add the text saying that PCES and PW are modulated using $\pi/2$ BPSK
- Resolution: Accept the comment. The following sentence shall be added in Section 12.2.5.5.1: **“PW is modulated with $\pi/2$ BPSK”**, and also, the following sentence shall be added in Section 12.2.5.5.2: **“PCES is modulated in the same manner of PW”**.

Comment 12 (SC PHY, Editorial)

- There is no definition on the length of subblock.
- HZ proposal: define the length of subblock
- Resolution: Accept the comment.
“subblock” shall be removed.

Comment 13 (SC PHY, document modification)

- Figures 187 and 212 should be drawn with the same convention.
- HZ proposal: Moving from left to right, first SYNC, then SFD, CES.
- Resolution: Accept the comment partially. Fig 187 shall be changed to keep consistency with Fig 212. The order of SYNC, SFD, CES shall be from right to left.

Comment 14 (SC PHY, document modification)

- Sec. 12.2.2.2.1 -- Generator polynomials are not narrow-sense. Does not make a difference to performance, but was this specifically intended?
- Resolution: Accept the comment. The following narrow-sense generator polynomial shall be added in 12.2.2.2.1.

$$g(x) = \prod_{k=0}^{15} (x + \alpha^k)$$

$$= x^{16} + \alpha^{120}x^{15} + \alpha^{104}x^{14} + \alpha^{107}x^{13} + \alpha^{109}x^{12} + \alpha^{102}x^{11} + \alpha^{161}x^{10} + \alpha^{76}x^9 \\ + \alpha^3x^8 + \alpha^{91}x^7 + \alpha^{191}x^6 + \alpha^{147}x^5 + \alpha^{169}x^4 + \alpha^{182}x^3 + \alpha^{194}x^2 + \alpha^{225}x^1 + \alpha^{120}$$

Comment 25 (SC MAC, technical)

- Currently we allow different subframes in the aggregated frame being modulated using different MCSs. That will unnecessarily increase the receiver implementation complexity, and in some cases may lead to catastrophic performance drop regarding error rate, due to the MCS switches over subframes.
- HZ proposal: We may need to reconsider the impact of MCS switching over aggregated subframes, on the receiver designs, and probably use the same MCS all through the aggregated packet (like AMPDU in 802.11n), and only signal the unified MCS by PHY header.
- Resolution: Reject the comment. Since our aggregation is integrated MSB and LSB subframes, switching the MCS over subframes is unavoidable. Currently there are no changes proposed on the aggregation scheme.

Comment 26 (SC PHY, Technical)

- This paragraph needs elaboration. How is SFD2 defined to indicate CES length. Is it reliable enough to only use SFD1 as delimiter, regarding frame timing reference detection?
- Resolution: Accept the comment partially. The following sentence shall be added in line 8 of sub-clause 12.2.3.2 as "If the value of SFD2 is 1, it means long CES. On the other hand, if the value is 0, it means short CES."

Regarding frame timing reference detection using only SFD1, the answer is YES. It is reliable. So far no problem has been observed by our simulation.

Thank you!