

Project: IEEE P802.15 Working Group for Wireless Personal Area Networks (WPANs)

Submission Title: [Introduction of Human Body Communication]

Date Submitted: [11 Jan, 2008]

Source: [Hyung-il Park, Sung Weon Kang]

Company [Electronics and Telecommunications Research Institute]

Address [161 Gajeong-dong, Yuseong-gu, Daejeon, 305-700, KOREA]

Voice:[+82-42-860-1316]

FAX: [+82-42-860-6860]

E-Mail:[hipark@etri.re.kr]

Re: []

Abstract: [This document presents BAN-related Communication method]

Purpose: [To propose Communication method for BAN]

Notice: This document has been prepared to assist the IEEE P802.15. It is offered as a basis for discussion and is not binding on the contributing individual(s) or organization(s). The material in this document is subject to change in form and content after further study. The contributor(s) reserve(s) the right to add, amend or withdraw material contained herein.

Release: The contributor acknowledges and accepts that this contribution becomes the property of IEEE and may be made publicly available by P802.15.

Introduction of Human Body Comm.

Hyung-il Park and SungWeon Kang

ETRI

Jan.2008

Purpose and Contents

- This document presents the comm. method for the BAN

- Contents
 - Introduction
 - Challenge
 - HBC System Review
 - Summary

What is HBC ?

Introduction

- BAN Comm. Tech. to transfer information through a human body

Wireline Comm.

- Heavy wiring
- Uncomfortable
- High S/N ratio
- High data rate

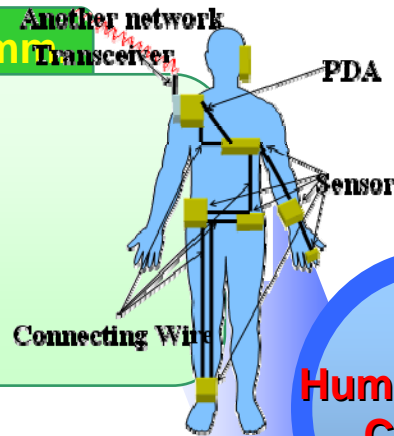

Wireless Comm.

- Heavy wireless equip.
- Uncomfortable
- Low efficient data transfer
- Errors in data transfer

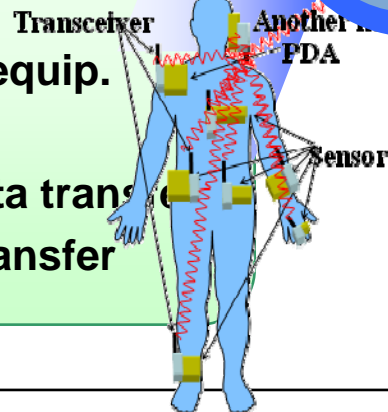

Human Body Comm.

- Less expensive
- No wiring
- Small size
- Small power consumption
- High data rates
- High signal to noise ratio

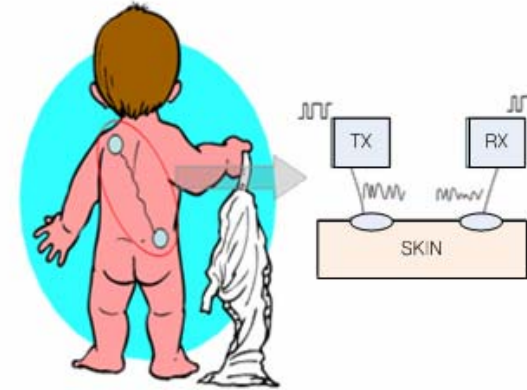

HBC Application

Introduction

- Build up Network among a lot of digital equipments
 - Loaded in Mobile phone, TV, MP3 Player, Digital Camera, Notebook, Printer, Smart Home Network, Endoscope, ...
 - Support Ubiquitous Service by intuitive touching



HBC Application

Introduction

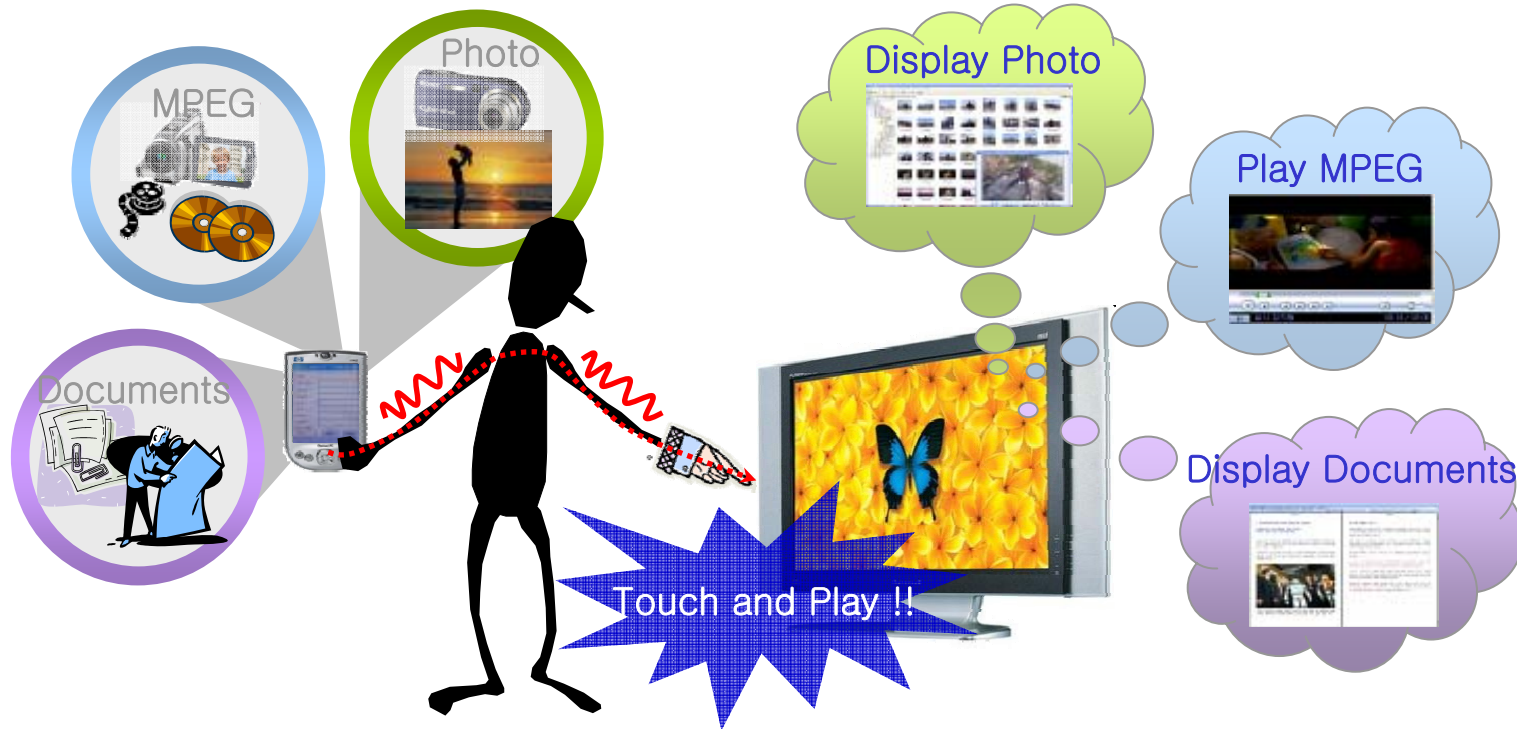

Why HBC ?

Introduction

- Competition Service
 - Bluetooth, ZigBee, UWB, NFC ...
 - Takes long times to setup a call
 - Power Consumption by using RF signaling
- Requirements...
 - Protocol:
 - Context Aware Service, Intuitive Service, Quick Development
 - Expandability, Coexistence with Other Technology
 - Ad hoc Sensor Monitoring
 - PHY
 - Low Power Consumption for Mobile Equipment
 - Support High Data Rate

Challenge

Human Body as a Channel?

- The First Try...
 - Source: Multimedia Transmitter
 - Connect IF Signal of Multimedia Transmitter to the Human Body
 - Play the received Movie at Notebook
 - Data Rate: 2Mbps
 - BER: 4.7×10^{-6} @ SNR = 16.7 dB

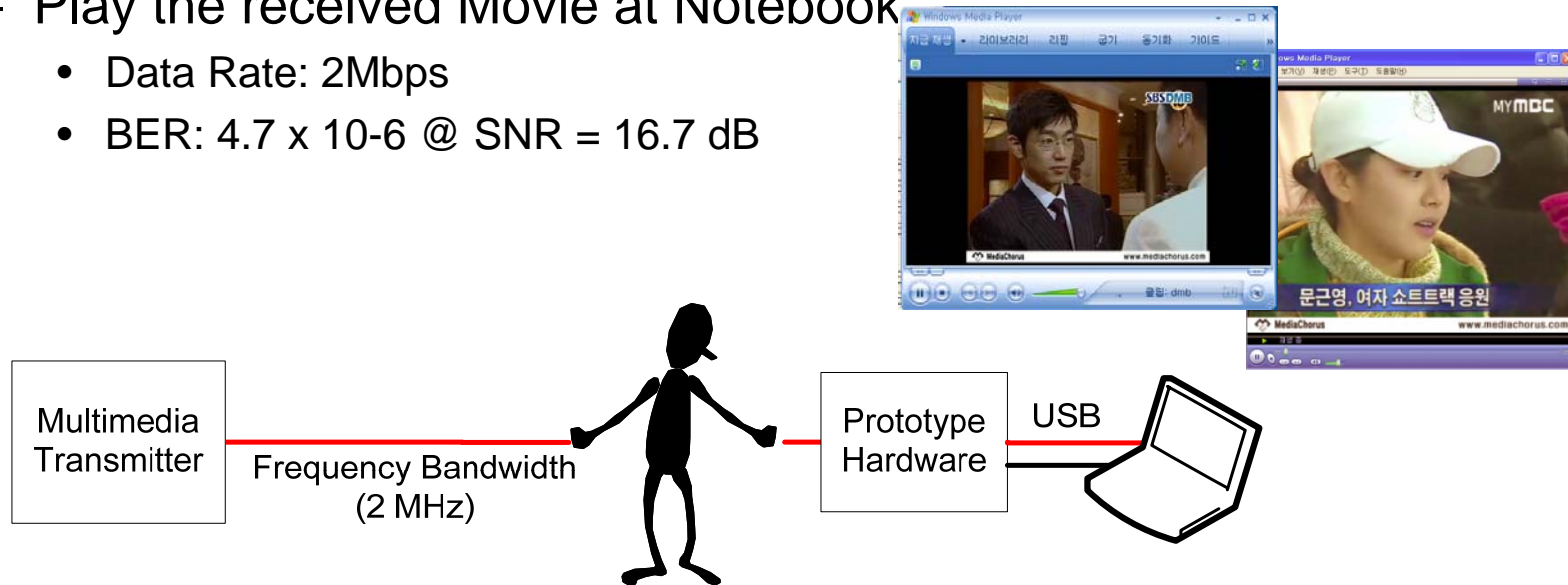

Challenge

Human Body as a Channel?

- The Second Try...
 - Source: Mobile Phone to support DMB service

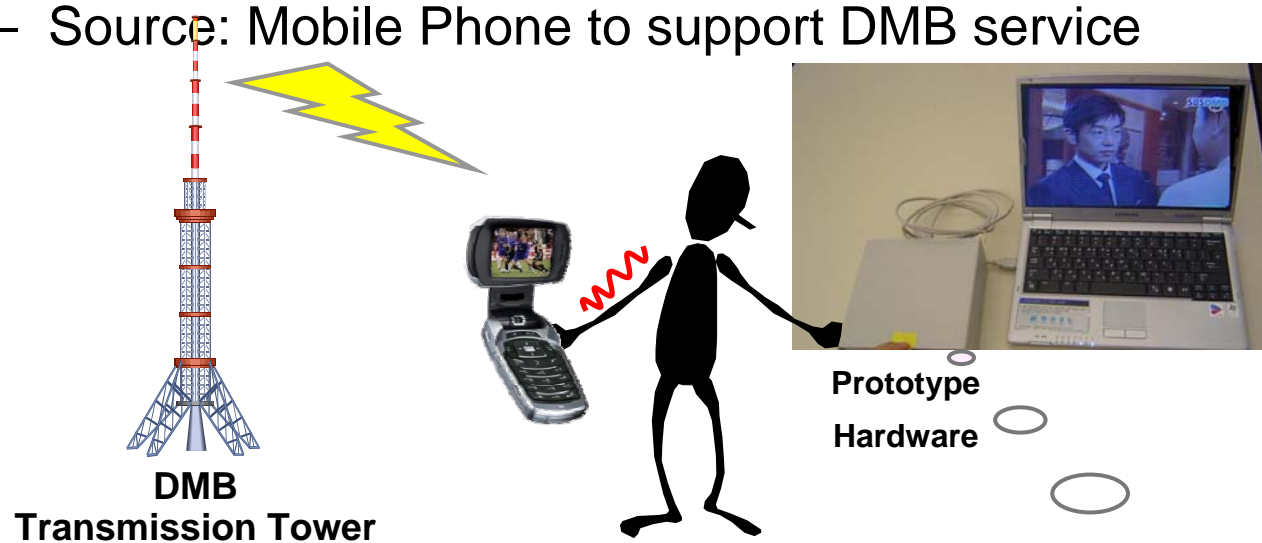

$BER \leq 10^{-3}$ @
 $SNR > 6$ dB

Demo

Challenge

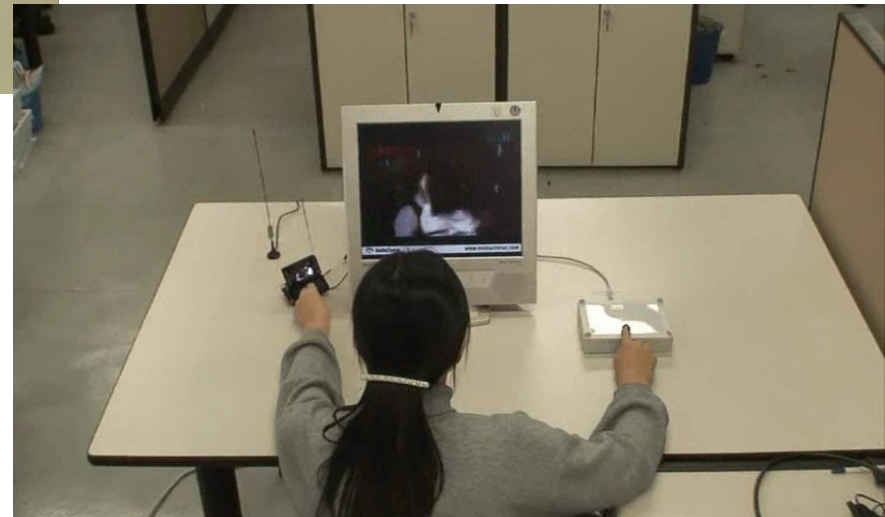

HBC System Review

Characteristics of Signal and Noise

● Noise

- Heavy amount noise in Low Frequency,
- Need to escape Low Frequency Band

● Signal

- Emit Bigger power outside body as Frequency increase
- Body become antenna
- Need to specify the effective band

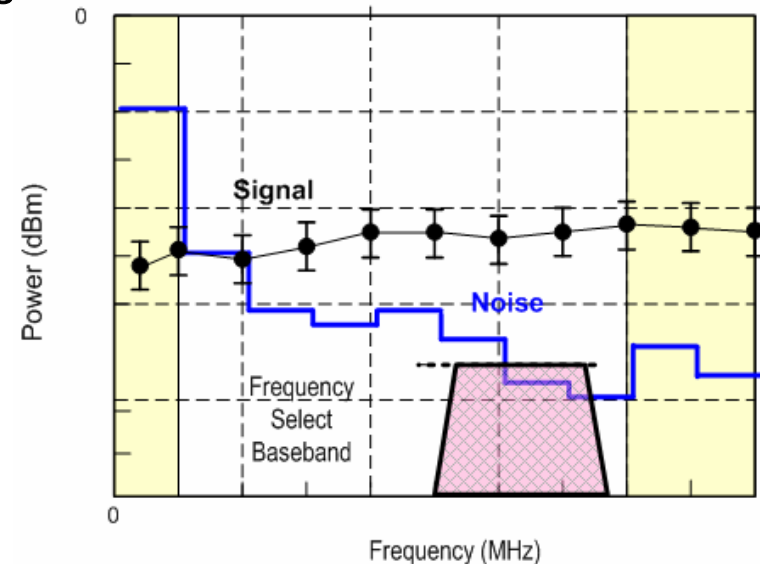

HBC System Review

Characteristics of Walsh 64

- Each Walsh Code has the major frequency components
- Select the 4th sub-group of Walsh 64

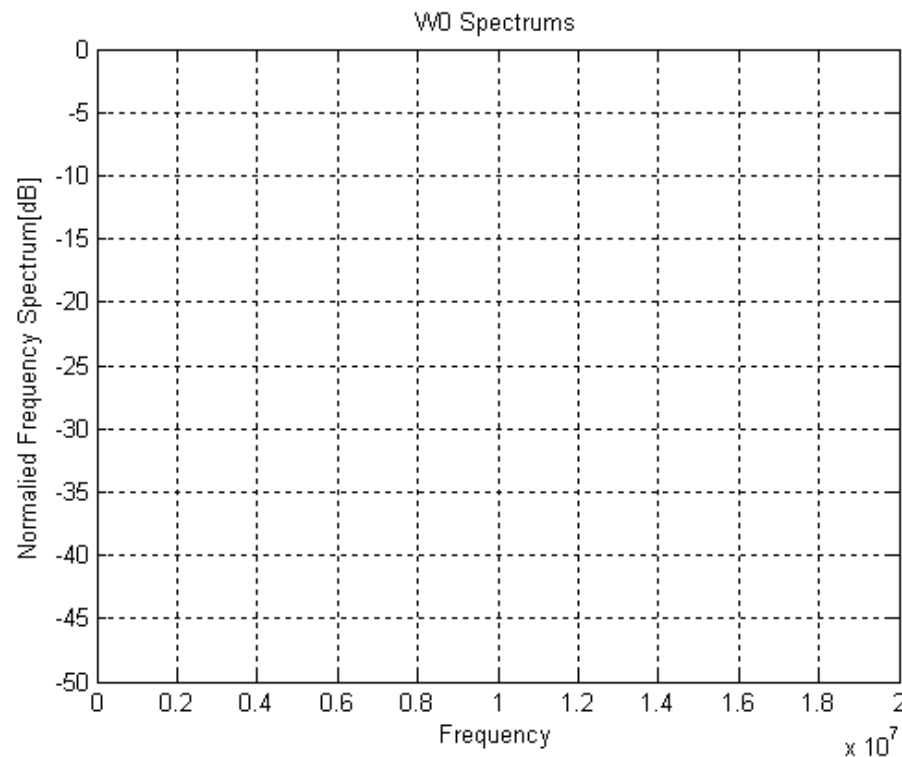

HBC System Review

FS-CDMA

- Method to transfer the baseband signal by using the characteristics of Walsh code
- S2P make 4bit symbols, then the symbols become the index of Walsh code
- FS-Spreader output the one code of the 4th sub-group

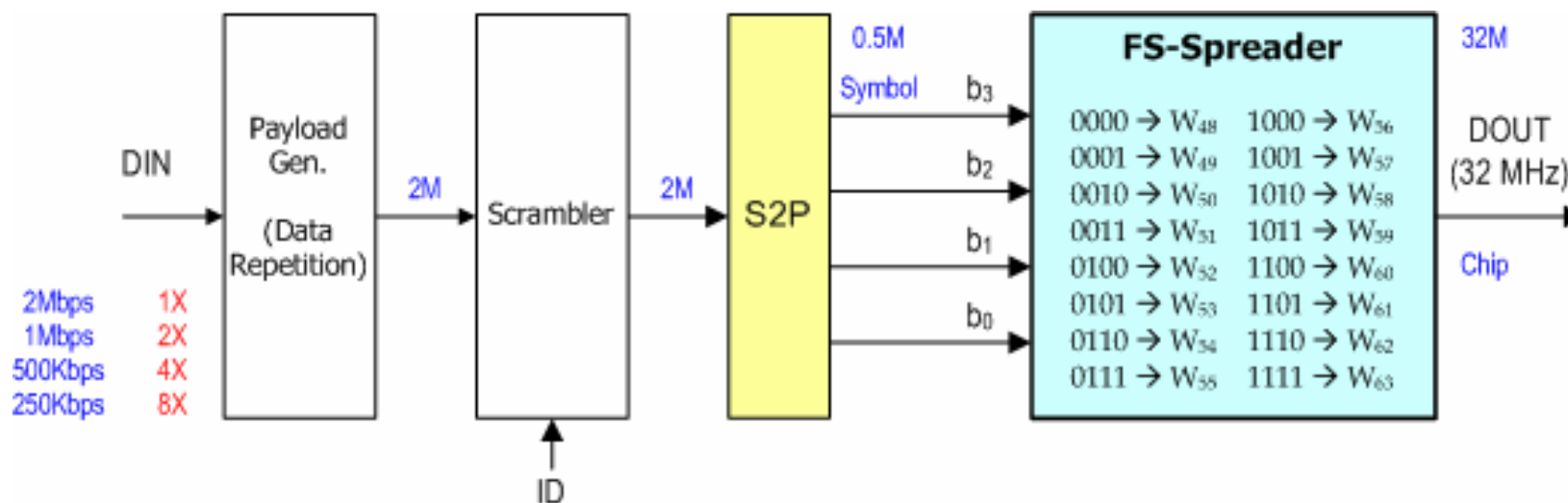

HBC System Review

Physical Parameter

Parameters	Values
Bandwidth	Frequency Selective Baseband (12 MHz ~ 16 MHz)
Comm. Env.	Intra Body Communication
TX Method	Direct Digital Transmission
Duplex	TDD
Frame Length	10 ms
Preamble	$P(z) = z^6 + z^5 + 1$
Scrambling	32bit PRBS generator : $P(z) = z^{32} + z^{31} + z^{11} + 1$
Spreading	Frequency Selective 64 chip Walsh Modulation
Data Rate	2 Mbps ~ 250 Kbps

HBC System Review

Block Diagram of HBC PHY

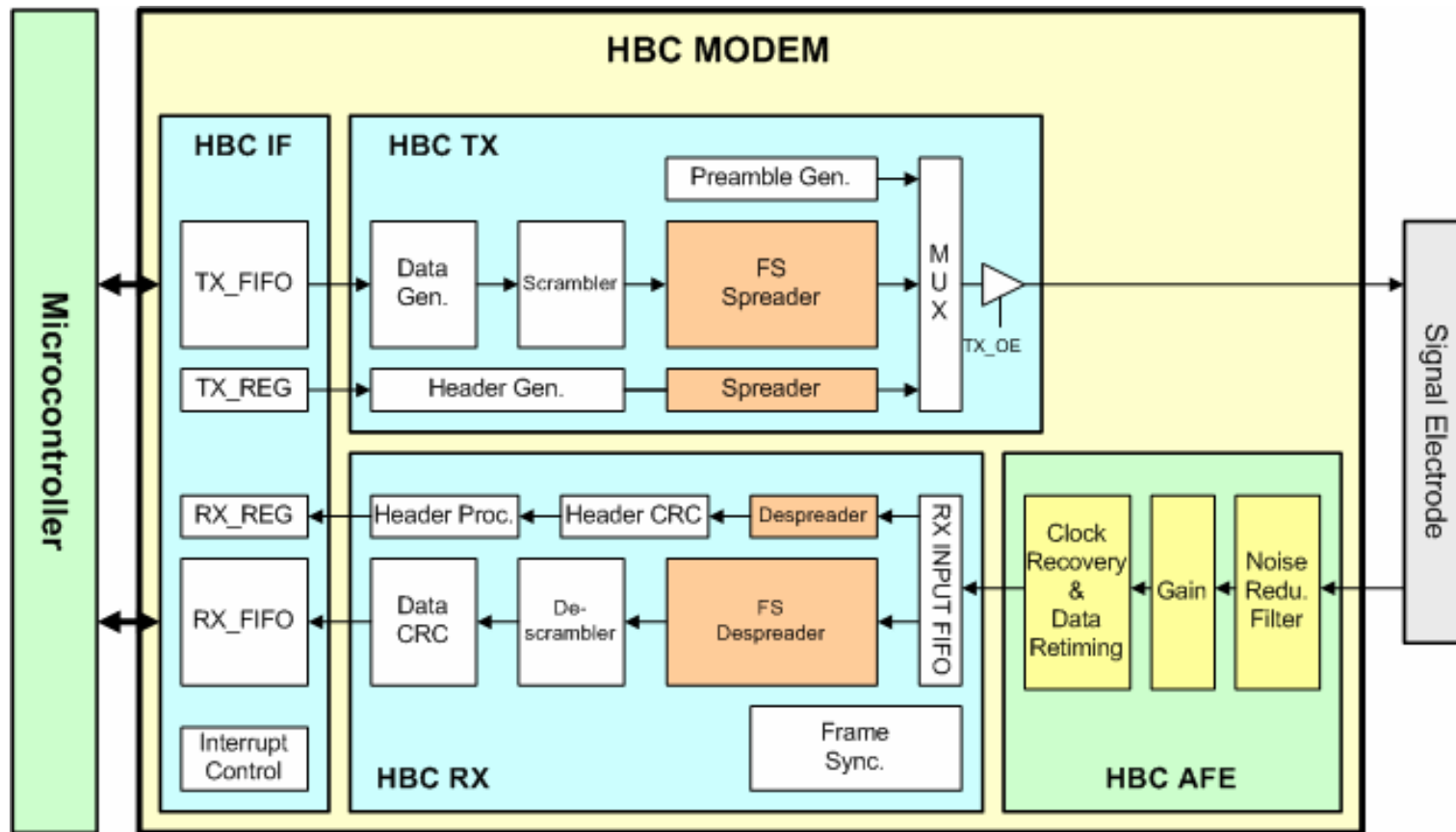

HBC System Review

Frame Structure

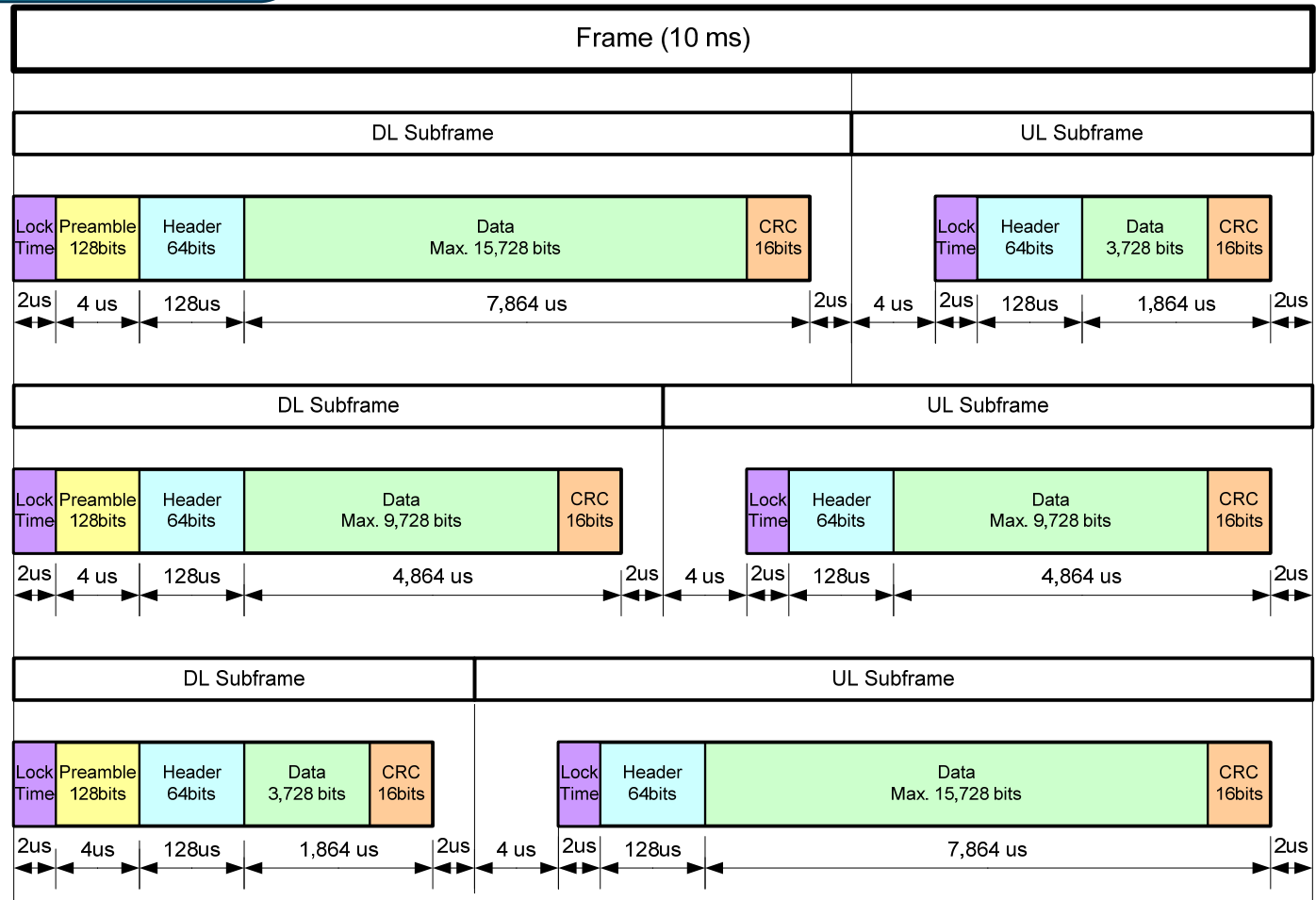

HBC System Review

Demo of Video transmission



Currently Status

- 2Mbps HBC Controller

- Developed the Modules of HBC Controller
- Obtained BER of 10^{-6}
- Verified some applications: transfer Video, transfer high quality Picture, transfer photograph from UMPC to Printer, ...
- Developed the chips of HBC Controller, being verified by some applications



- 10Mbps HBC Controller

- Developed the Modules of HBC Con
- Being verified by some applications

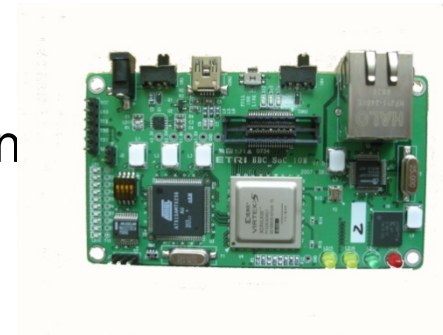

Summary

● What is Human Body Communication?

- BAN Communication Technology to transmit information through a human body
- Introduce some applications...

● Human body as a channel?

- It is possible to transfer digital signals through a human body

● HBC System Review

- Specify the effective Band
- Use Walsh Code to minimize interference → FS-CDMA

● Currently Status of HBC System

- Developed The 2Mbps modules and chips
- Developed The 10Mbps modules



Thank you for your attentions!