

Project: IEEE P802.15 Working Group for Wireless Personal Area Networks (WPANs)

Submission Title: [Scenario in Standardization of PHY/MAC for wearable and implant BAN's]

Date Submitted: [November 12, 2007]

Source: [Ryuji Kohno, Kenichi Takizawa, Bin Zhen, Huan-Bang Li, Kamyaz Yazdandoost, Tetsushi Ikegami, and Shin Hara]

Company [National Institute of Information and Communications Technology (NICT)]

Contact: Ryuji Kohno

- **Voice:**[+81 46 847 5108 E-Mail: kohno@nict.go.jp]

Abstract: [This document describe wearable BAN and implant BAN.]

Purpose: [To help discussion in IEEE 802.15.MBAN.]

Notice: This document has been prepared to assist the IEEE P802.15. It is offered as a basis for discussion and is not binding on the contributing individual(s) or organization(s). The material in this document is subject to change in form and content after further study. The contributor(s) reserve(s) the right to add, amend or withdraw material contained herein.

Release: The contributor acknowledges and accepts that this contribution becomes the property of IEEE and may be made publicly available by P802.15.

Scenario in Standardization of PHY/MAC for Wearable and Implant BAN's

Ryuji Kohno, Kenichi Takizawa, Bin Zhen, Huan-Bang Li,
Kamyaz Yazdandoost, Tetsushi Ikegami, and Shin Hara

National Institute of Information and Communications
Technology (NICT)

Contents

- Introduction
- Key Issues to Decide PHY/MAC for BAN
- Reference of Ready Existing Standards
- Classification of Possible Combination of PHY and MAC for wearable and implant BAN's
- Benchmark
- Questions for Further Study; Open Issues

Introduction

- We presented a scenario for possible PHY/MAC in Nov. 2006. (Doc. No. IEEE802.15.06.487.r0)
- There are still few presentations of possible PHY/MAC in this study group, e.g. some type of UWB.
- To get a consensus of standardization on PHY/MAC, we need to fix :
 - ✓ Concrete frequency band
 - ✓ Concrete channel characterization
 - ✓ Concrete PHY specification, e.g. modulation/coding scheme
- We can refer PHY/MAC of ready existing standards
 - ✓ IEEE 802.16-2004
 - ✓ IEEE 802.15.4-2003, 802.15.4a-2007

Key Issues to Decide PHY/MAC for BAN

To decide a standard of PHY/MAC for BAN, we should take into account of the following key issues,

1. Regulatory Compliance; FCC and other regional regulations

➡ Band Plan

2. Size of Markets ➡ Single or Limited No of PHY/MAC

3. Channel Characteristics for Wearable/Implant BAN's

➡ PHY is dependent on Channel but MAC is not

4. Covered Applications ➡ QoS, Reliability, and Security

5. Distinction and Relationship with Other Standards

➡ Different Technical Requirement such as EMC, SAR

Reference of Ready Existing Standards

IEEE 802.16-2004 type

MAC

PHY1 or PHY2

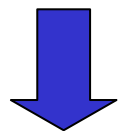

10-66GHz

frequency

- Data rate
- Modulation/coding
- Channel Characterization...

- No frequency band plan
- Double PHY's and a single MAC

IEEE 802.15.4-2003 type

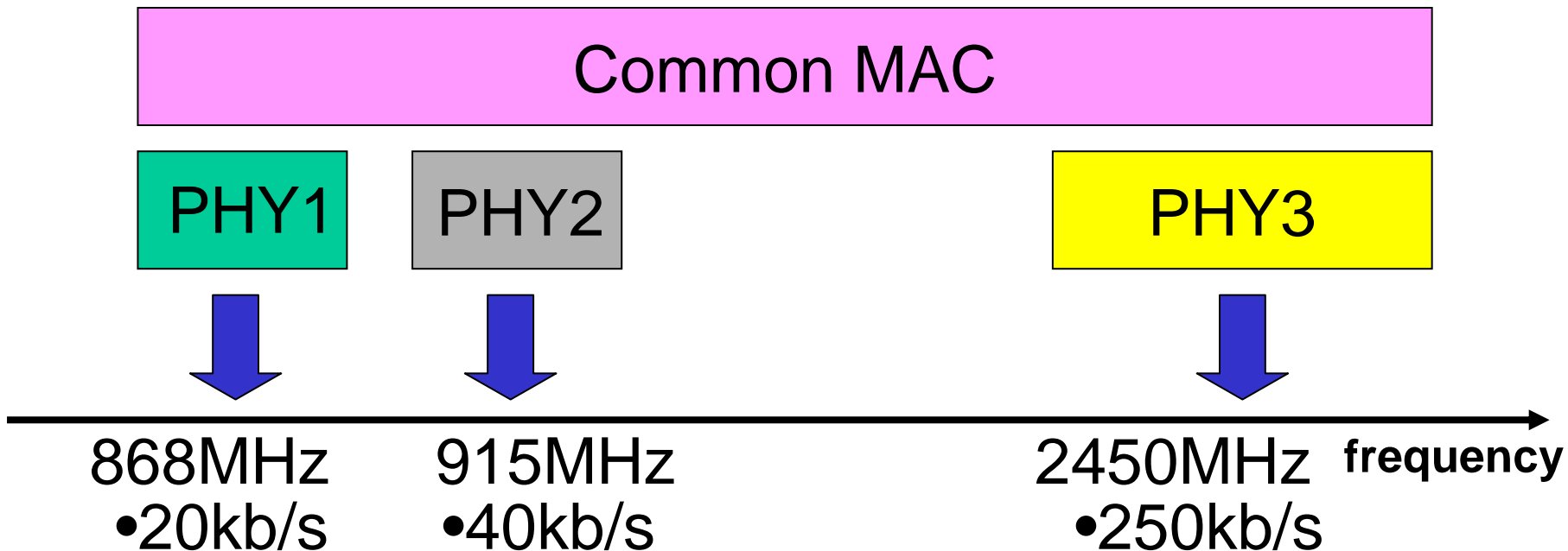

- Three frequency band plans
- An individual PHY in each band
- A single MAC in three bands

IEEE 802.15.4a-2007 type

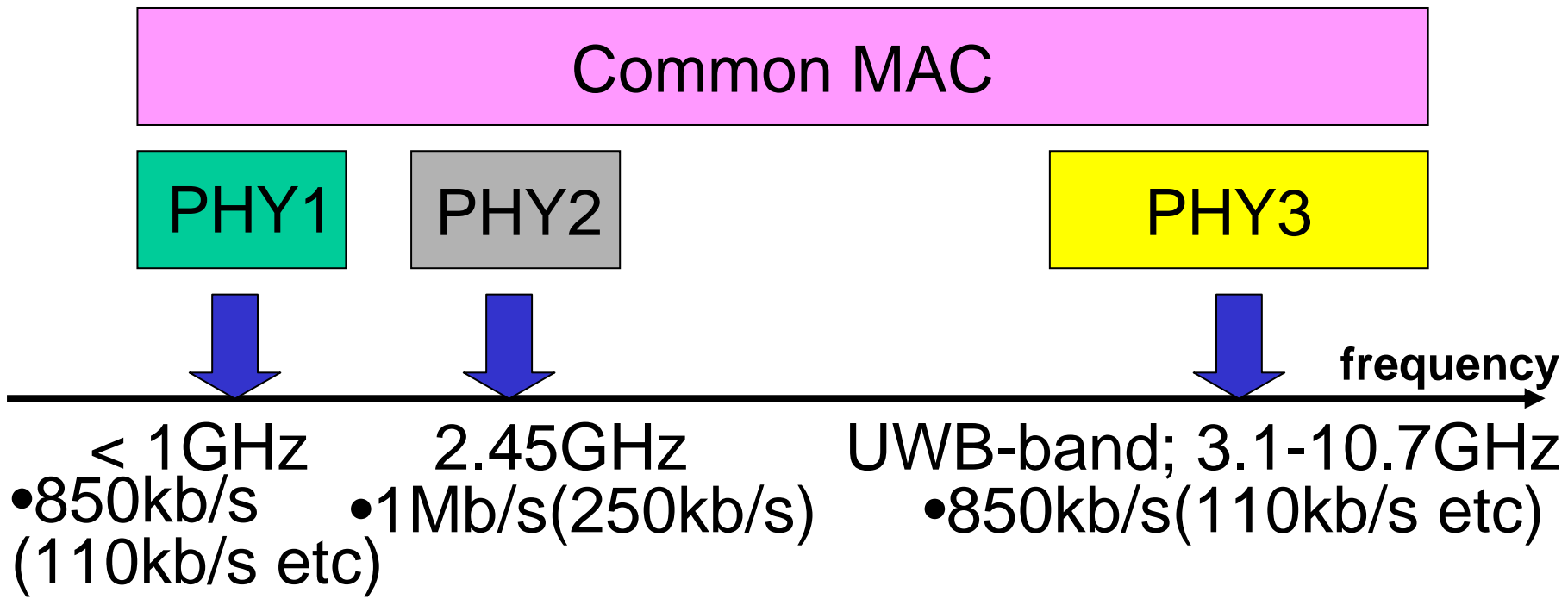

- Three frequency band plans
- An individual PHY in each band
- A single MAC(15.4) in three bands

To get a consensus in 802.15.BAN

- Before call for proposals, we need to get a consensus on some key issues for PHY/MAC, such as wearable/implant BAN, band plan, as well as TR and 5C under PAR.
- **Date rates:** Wide variety of data rates, such as over 10Mb/s in some entertainment applications, less than 10kb/s in some medical applications
- **Different Requirements:** Wearable devices and implanted devices for various applications
- **Band Plan:** Available frequency bands under various regional regulations

Possible Combination of PHY/MAC

Case 1

Wearable Devices/Implant Devices

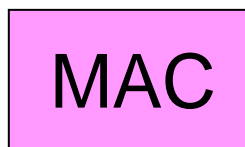
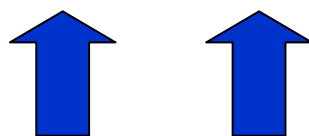

10 kb/s < *Data Rate* < 10 Mb/s

frequency

- Band plan specified
- A single PHY (scalable data rates supported: less than 10kb/s to 10Mb/s)
- A single MAC

Possible Combination of PHY/MAC

Case 2 Wearable Devices/Implant Devices

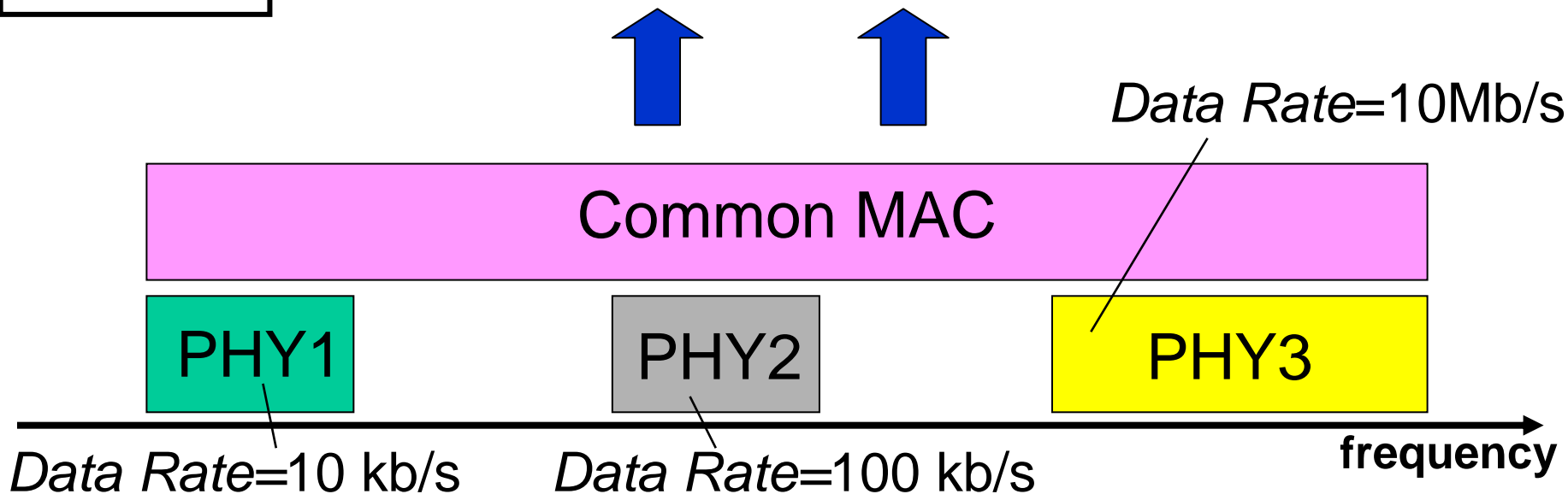

- Band plan specified
- Multiple PHY's (each supports an individual data rate)
- A single MAC

Benchmark

| | Regulatory Compliance | Market Size | Channel Characterization | Covered Applications | Distinction and Relationship with Other Standards |
|--|-----------------------|-------------|--------------------------|----------------------|---|
| Case1 A single PHY A single MAC | X | X | | | ? |
| Case2 Multi PHY's ;different data rates A single MAC | X | | X | X | ? |

Questions for Further Discussion

Question 1; Shall we make whether a single PHY/MAC or Multiple PHY's/MAC's?

>> If PHY/MAC suite in BAN is composed of multiple PHY's and MAC's, we cannot call it with a single standard.

Question 2-1; Should either PHY or MAC be single or common for wearable and implanted devices?

Question 2-2; Shall we first make a PHY/MAC for a wearable BAN and separately make a PHY/MAC for an implant BAN in process?

Question 2-3; Shall we start with a common standard for wearable/implant BAN, and then will make an amendment for an implant BAN?

Question 3-1; Which is a primary demand either medical or non-medical?

Question 3-2; Which shall we design; different or common PHY/MAC for medical and non-medical applications?

Question 3-3; Shall we support a single PHY/MAC for a specific class of applications and then deal the other applications as an amendment in a sense of step-by-step?

Question 4; Shall we support narrow band and/or UWB signaling in PHY?

Question 5; Shall we support 15.4 type of MAC?

Question 6; How can we distinguish 15.6 with 15.4a and 15.4e in PHY/MAC?

Question 7; When shall we expect to complete IEEE 802.15.6 in schedule?

Backup Slides

Categorization of BAN links

- Wearable BAN links
- Implant BAN links

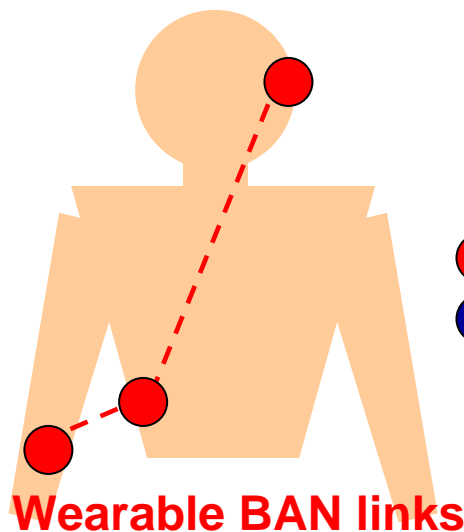

links between on-body devices
Applications: 15-06-0217,0219,0241

● : on-body devices
● : in-body devices

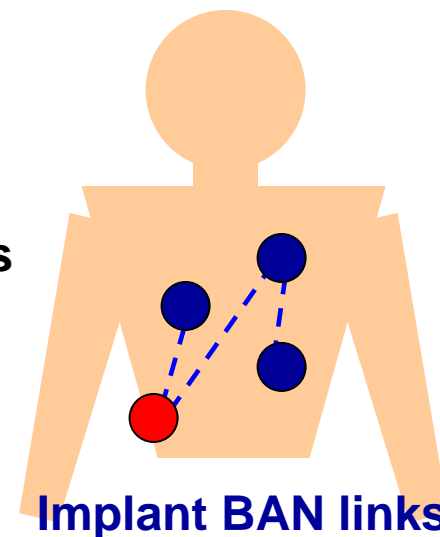

links between in-body and in-body/on-body devices
Applications: 15-06-0409

Doc: IEEE 802.15-06-0487-00-0ban, Nov. 15, 2006

Differences between wearable and implant BAN links

Wearable BAN links

Issues

Implant BAN links

ISM/UWB/others

**Current available
frequency band**
15-06-0340

400MHz MICS

Multipath model

Channel model

Path-loss model

•SAR
•Interference to other
wearable/implant
devices, e.g. pacemaker

Human body safety
15-06-0340

•SAR
•Interference to other
wearable/implant devices,
e.g. pacemaker
•Packaging materials

There are different technical aspects between wearable and implant BAN links.

Doc: IEEE 802.15-06-0487-00-0ban, Nov. 15, 2006

Argument on BAN PHY

- **Issue:** If we choose a single common PHY for both the wearable and implant BANs, they may not individually achieve desired performance.
 - Case 1: 400MHz-MICS band PHY
 - Suitable for implant links; but, it is hard to achieve high-throughput which is required in wearable links.
 - Case 2: 2.4GHz-ISM band PHY
 - In the wearable links, target throughput may be achievable. But, the range of the implant links will be quite limited.



Different PHYs may be necessary to provide optimal performance for wearable and implant BANs. (two-PHY solution)

Doc: IEEE 802.15-06-0487-00-0ban, Nov. 15, 2006

Problem with two-PHY solution

- To support two-PHY solution, inter-connectivity/operability between the two kinds of PHYs should be maintained to provide wide range of applications.
 - Eg. Simultaneous vital sign monitoring in and on the body

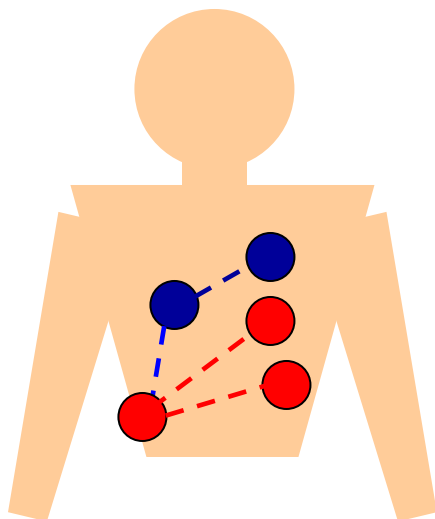

Wearable BAN: ECG/BP/HR monitoring

Implant BAN: Glucose level monitoring

--- : wearable links

--- : implant links

● : on-body devices

● : in-body devices

One approach for overall system

- 1st. Define different PHYs for the wearable and implant BAN links.
- 2nd. Provide inter-connectivity/operability between the two BANs by defining a *BAN-FFD*.

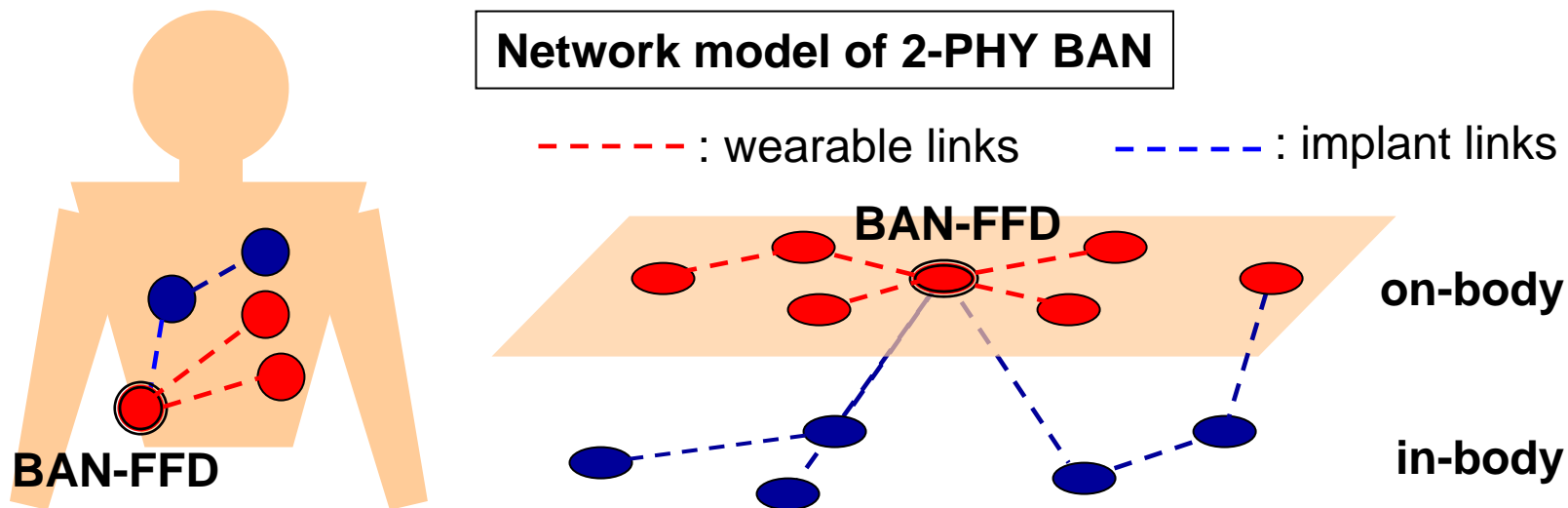

2-PHY solution is one possible approach to provide desired performance for wearable and implant BANs.

Another approach ?

- Studies are needed to find the possibility of a single PHY for both wearable and implant BAN links.
 - FCC generic unlicensed (Part15) provisions (?)

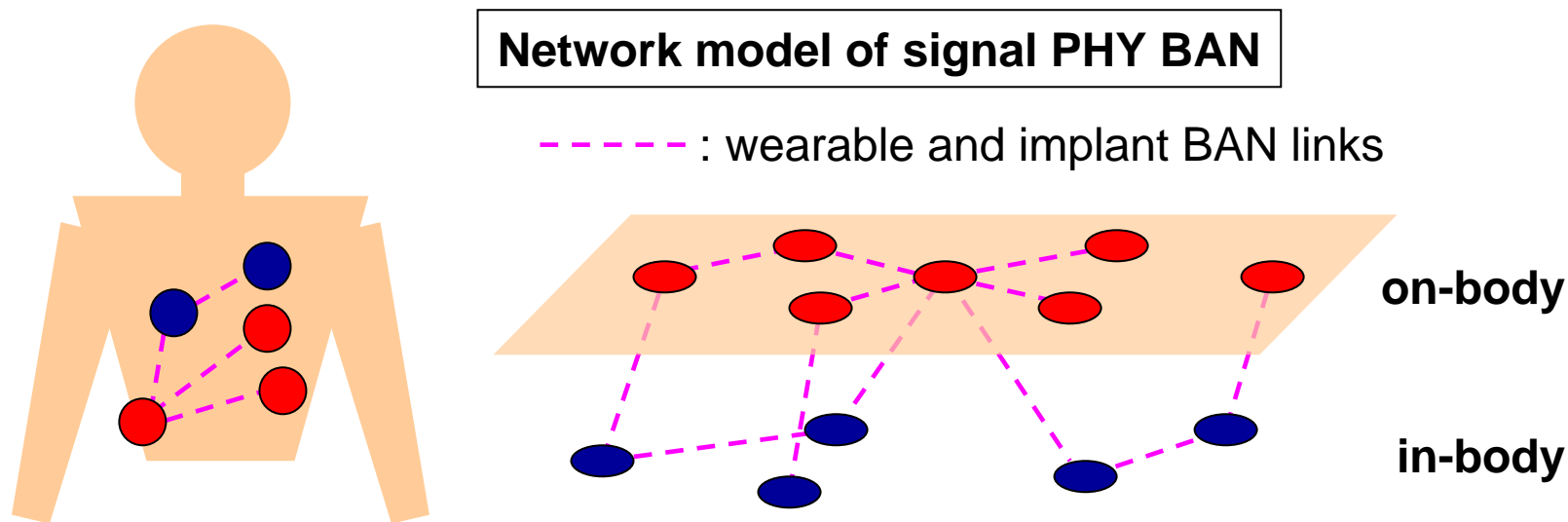

- Flexible and simple network

Doc: IEEE 802.15-06-0487-00-0ban, Nov. 15, 2006

Conclusion

- Differences between wearable and implant BAN links

| | Wearable BAN links | Implant BAN links |
|----------------|--|---|
| Frequency band | ISM/UWB/others | 400MHz-MICS |
| Channel model | Multipath model | Path-loss model |
| Human safety | SAR and interference to other devices e.g. pacemaker | SAR, materials, and interference to other devices, e.g. pacemaker |

- Issue: related to PHY selection for the BANs
- Possible approach: Two-PHY solution

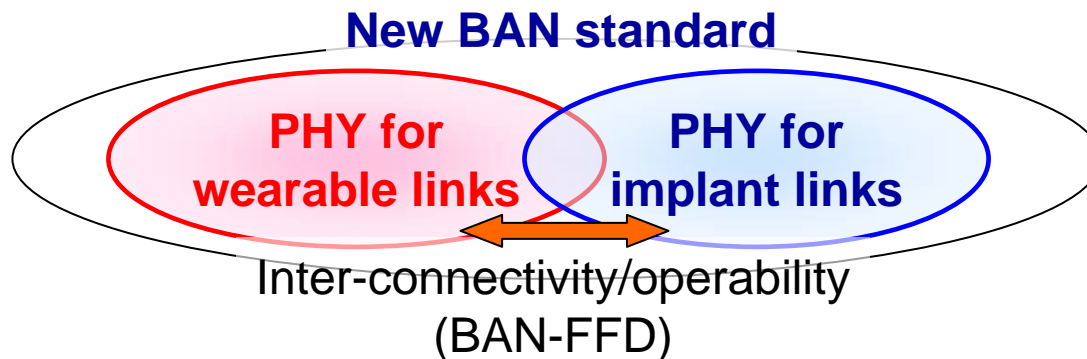

- Another approach: Single PHY solution