

**Project: IEEE P802.15 Working Group for Wireless Personal Area Networks**

**Submission Title:** [An Innovative High Speed Modem Implementation]

**Date Submitted:** [May 6,2007]

**Source:** [Abbie Mathew] Company [NewLANS, Inc.]

Address [43 Nagog Park, Suite 200, Westford, MA 01720, U.S.A.]

Voice: [(978) 849-8000], E-Mail: [amathew@newlans.com]

**Re:** []

**Abstract:** [NewLANS proposal]

**Purpose:** [Contribution to 802.15 TG3c interim in Montreal, Canada]

**Notice:** This document has been prepared to assist the IEEE P802.15. It is offered as a basis for discussion and is not binding on the contributing individual(s) or organization(s). The material in this document is subject to change in form and content after further study. The contributor(s) reserve(s) the right to add, amend or withdraw material contained herein.

**Release:** The contributor acknowledges and accepts that this contribution becomes the property of IEEE and may be made publicly available by P802.15.

# Scope of Proposal

- Focus on the modem
- Objective to work with companies with core competence in 60 GHz MMIC, antenna and digital circuitry for an integrated solution

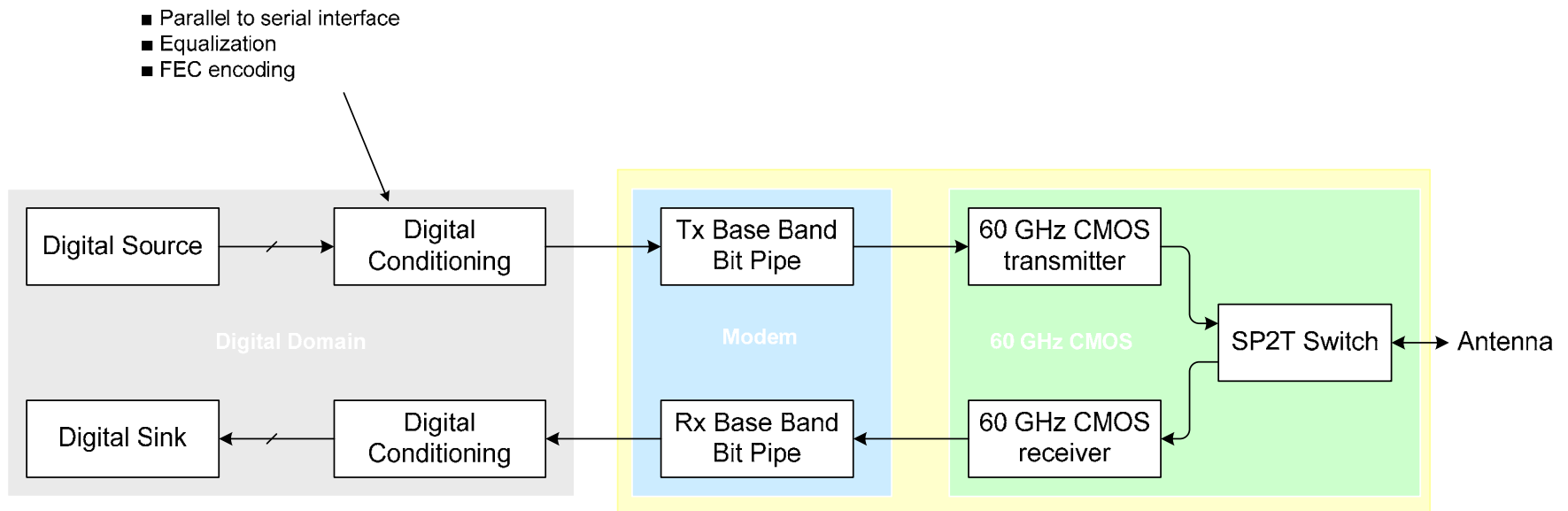

# Bipolar Coding Features Summary

- A synchronous clock encoding technique in PAM transmission
- Three level system
  - Logical 0 is represented by no symbol
  - Logical 1 by pulses of alternating polarity
- Inherent limited error detecting capability
- Zero spectral density at 0 and  $1/(2 \cdot \text{Baud Period})$
- No DC component

# Three Level System Bipolar Coding

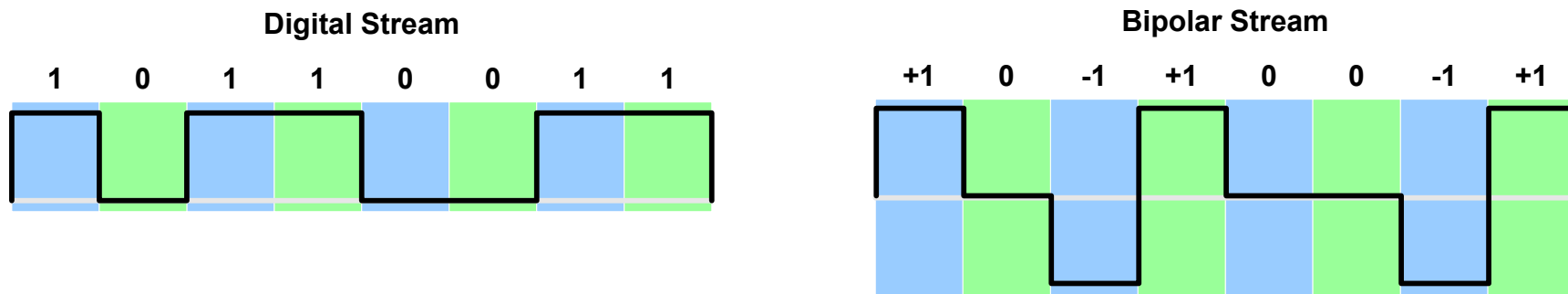

- Logical 1s represented by alternating polarity
- Logical 0 represented by no symbol

# Error Detection

## Bipolar Coding

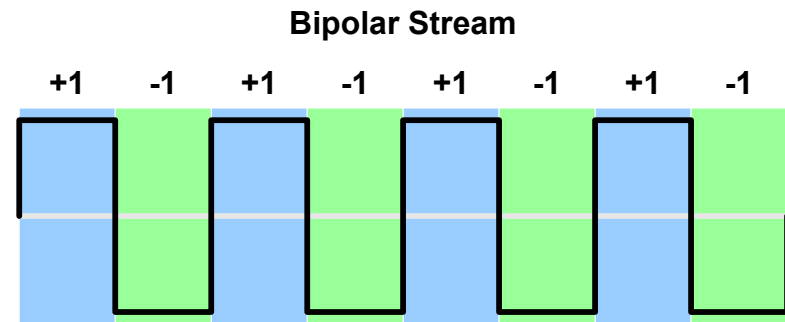
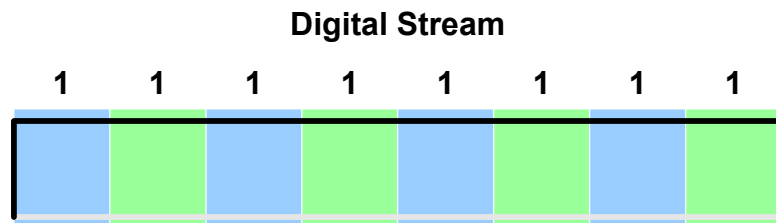

### Bipolar Violation

Consecutive pulses cannot have the same polarity

# Bipolar Coding With Dual Rail

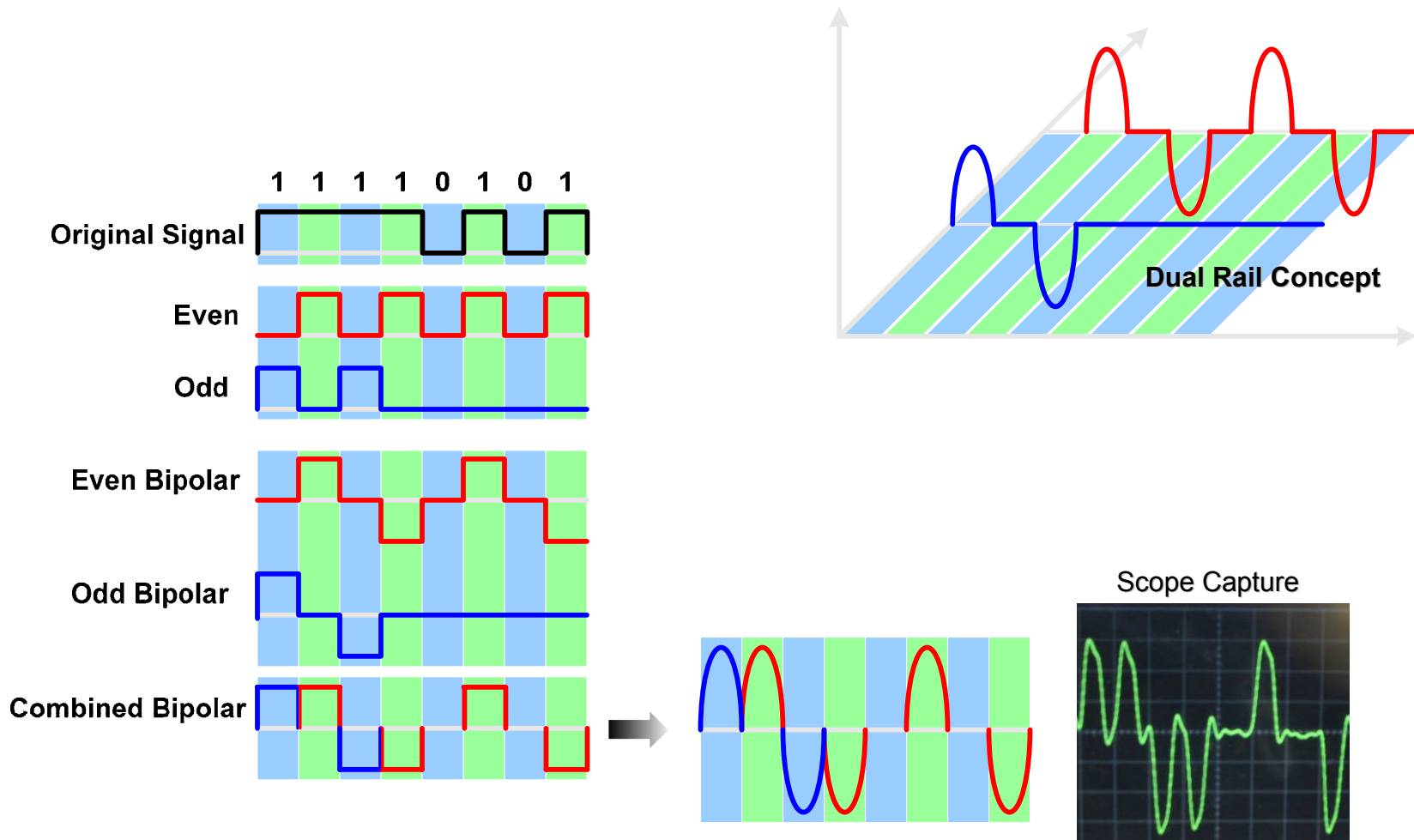

# Power Density Profile

## Bipolar Coding With Dual Rail

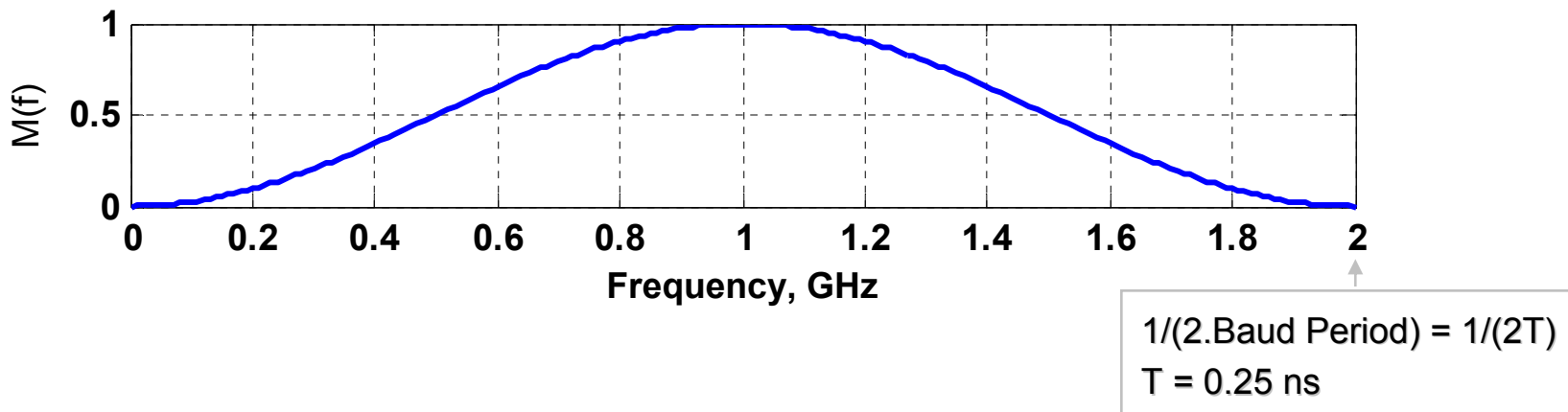

- Zero spectral density at 0 and  $1/(2T)$
- No DC component

# Pulse Shape

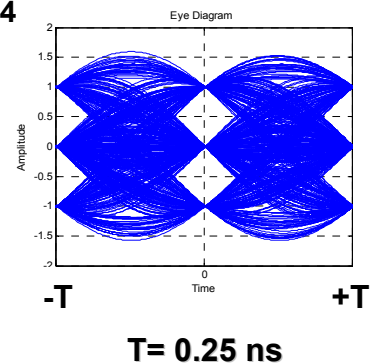
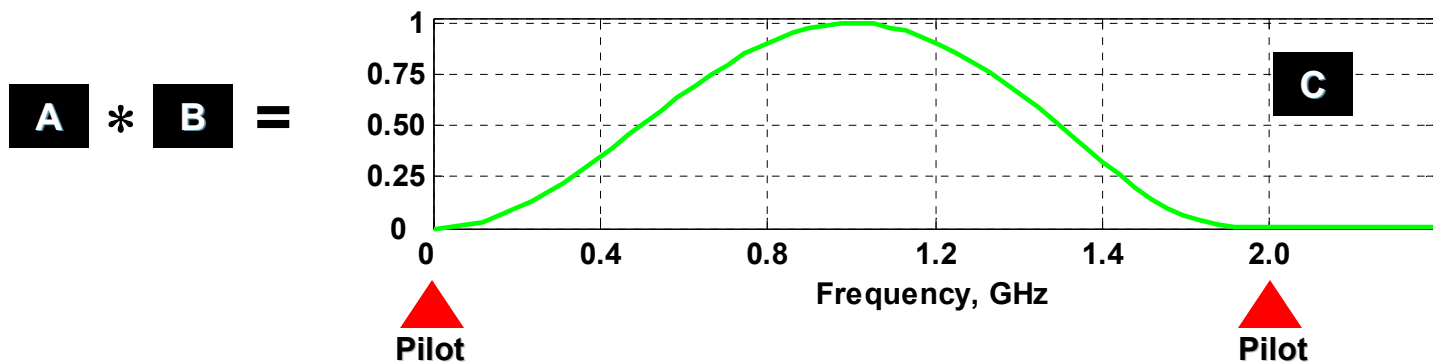
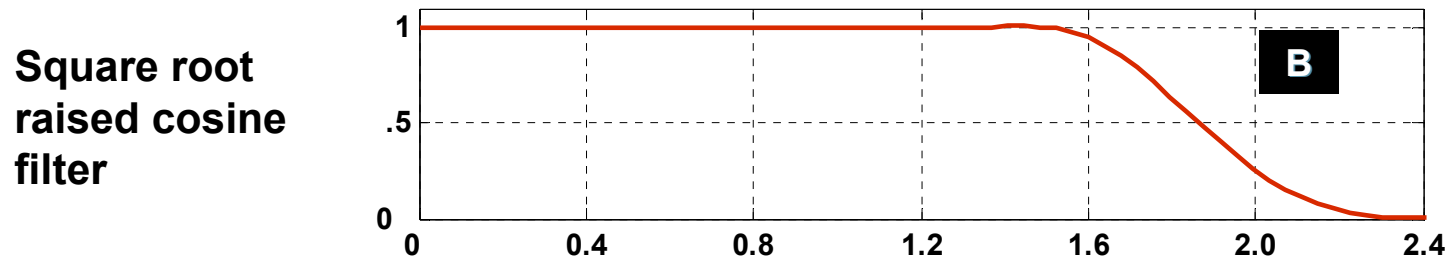
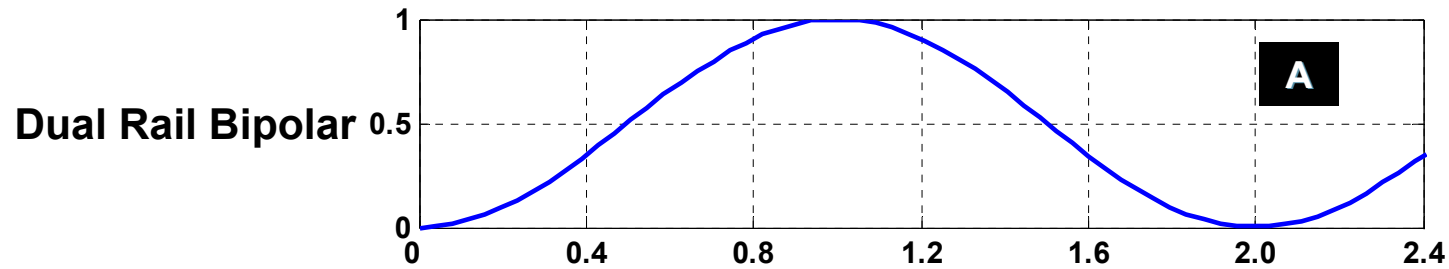



# Pilot Tones

- Inserted at 0 and  $1/(2T)$ , points of zero power density
  - Minimum effect on peak-to-average-power ratio
- Clock always coherent with data signal
- Features offered
  - Relatively immune to phase noise and frequency errors at 60 GHz
  - Fast data recovery ( $\sim 100$  ns) by virtue of no Costas loop
  - Fast AGC (40 dB dynamic range, 1% of actual value in  $\sim 10$   $\mu$ s)

# Functional Block Diagram Existing Prototype (500 MHz, 1 Gbps)

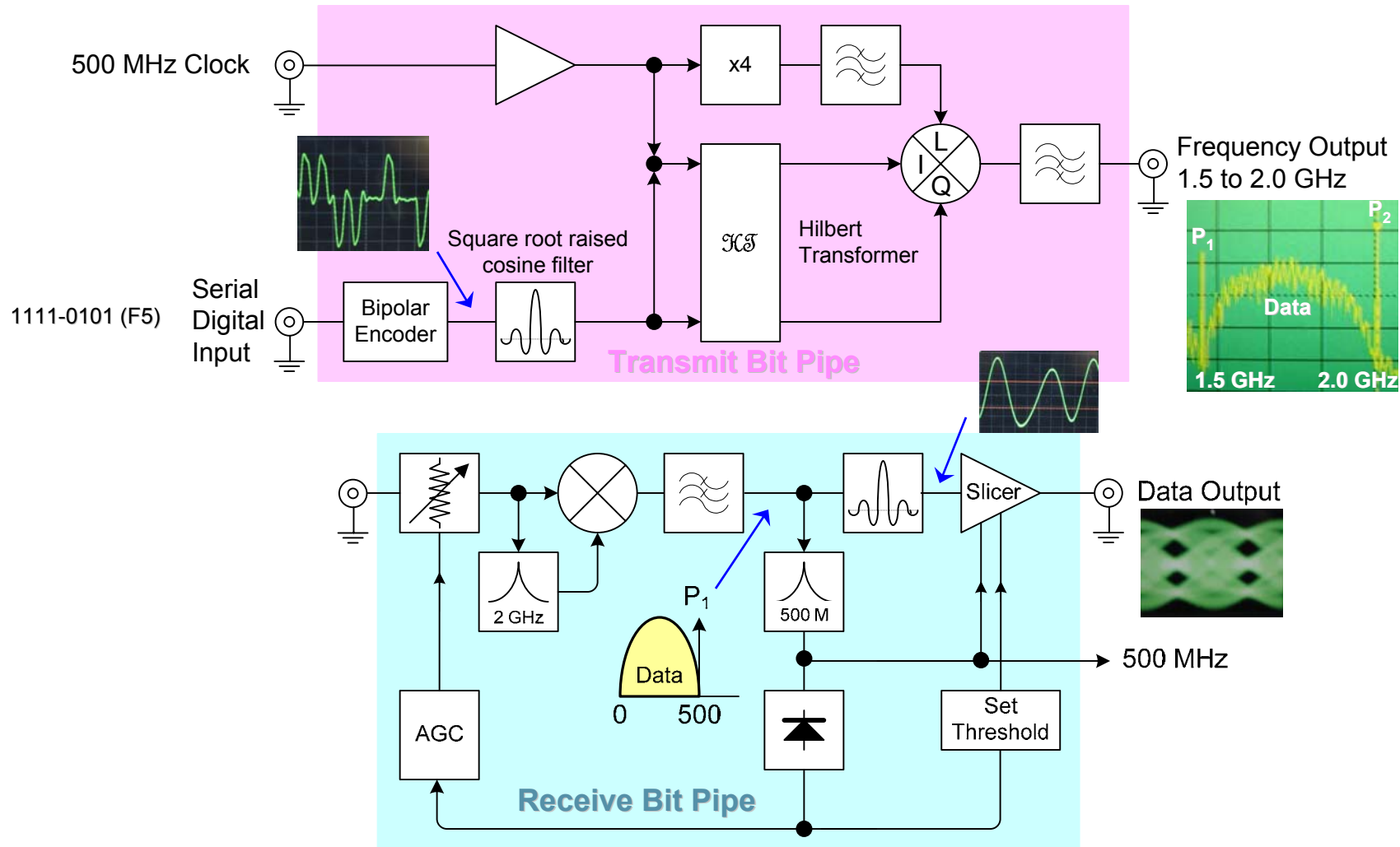

# Prototype Schedule

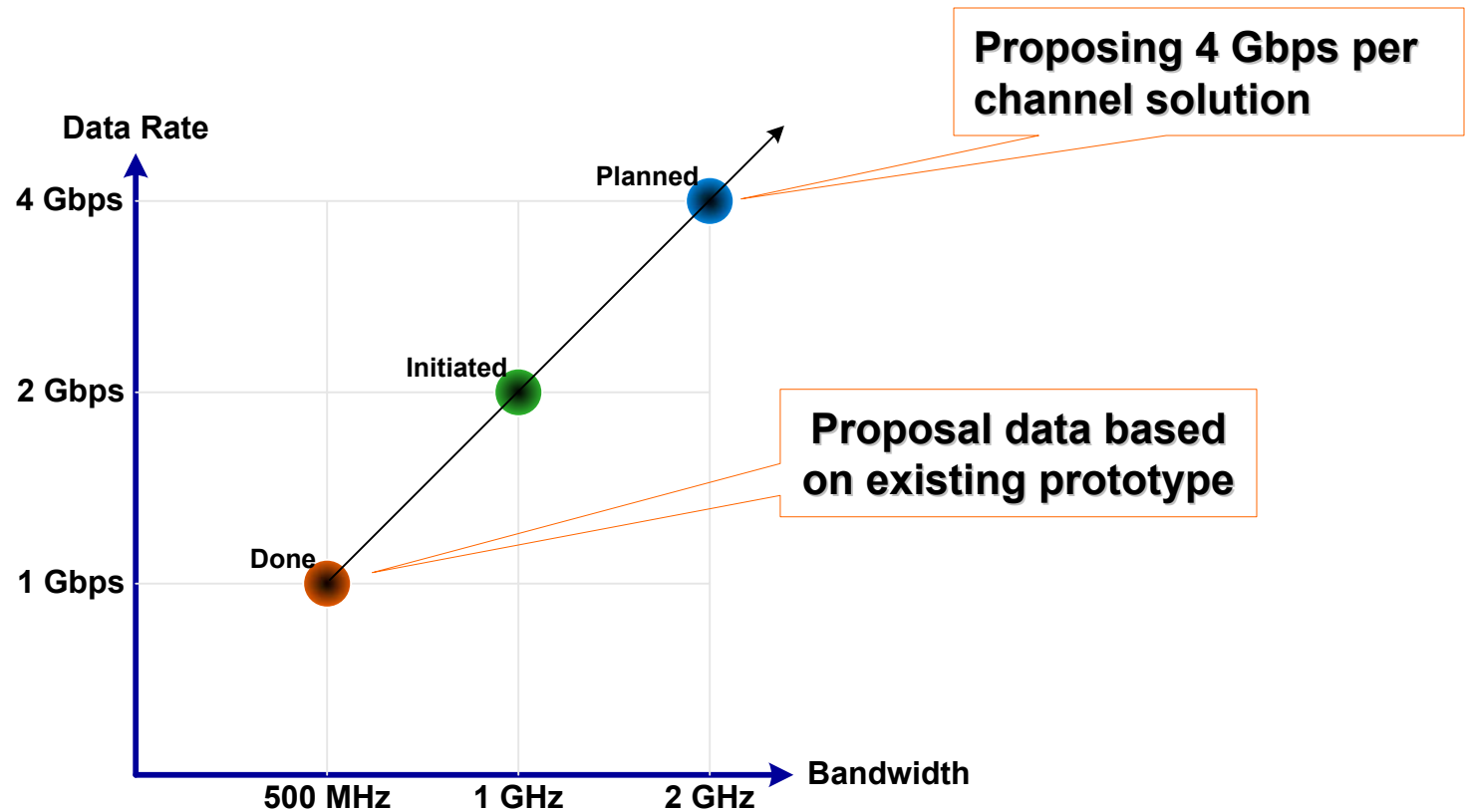

**Note**

- Spectral efficiency of 2 bps/Hz
- Prototype built on off-the-shelf components

# Transmitted Waveform

## Frequency Domain and Time Domain

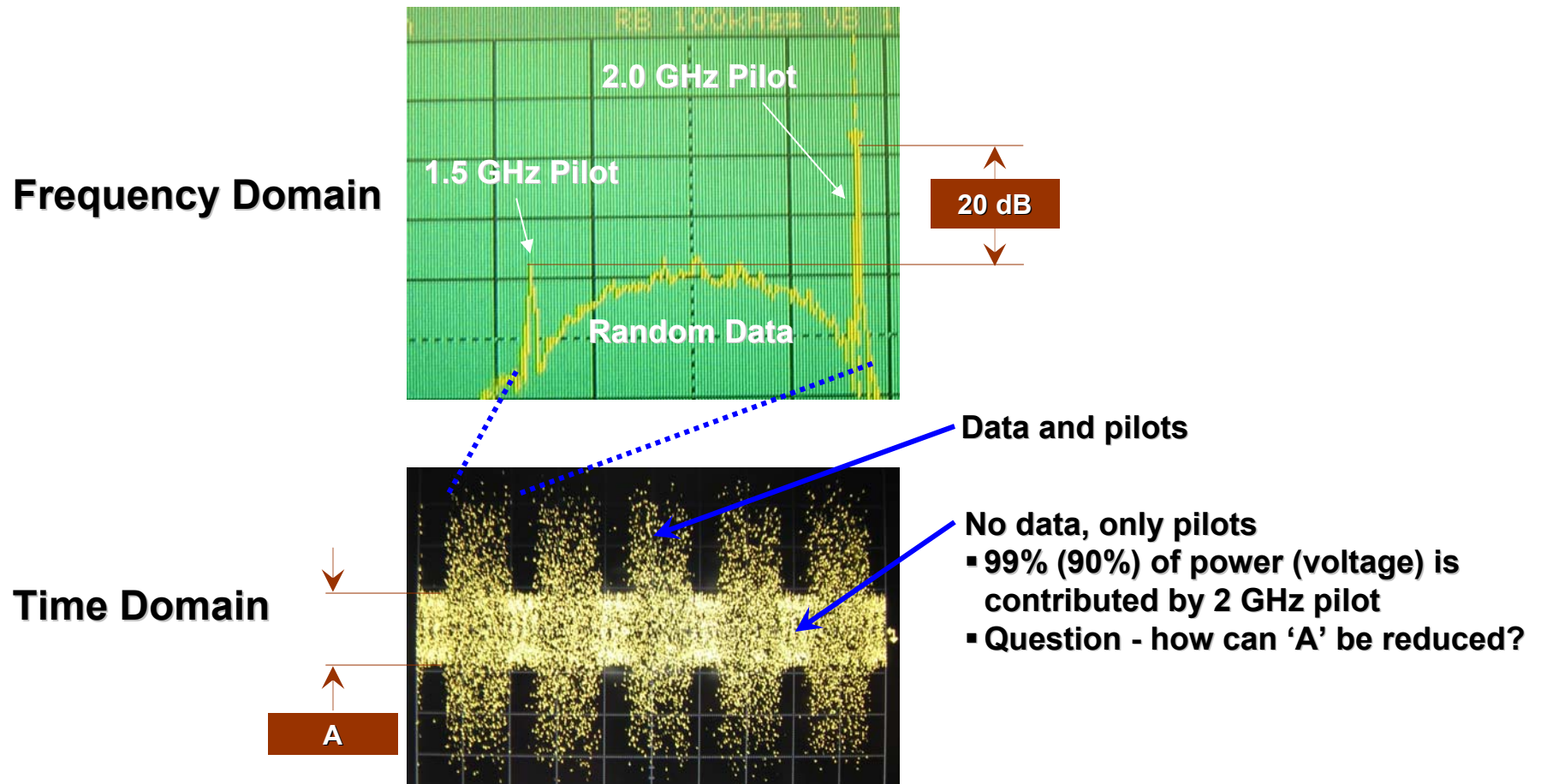

# Change in Pilot Level

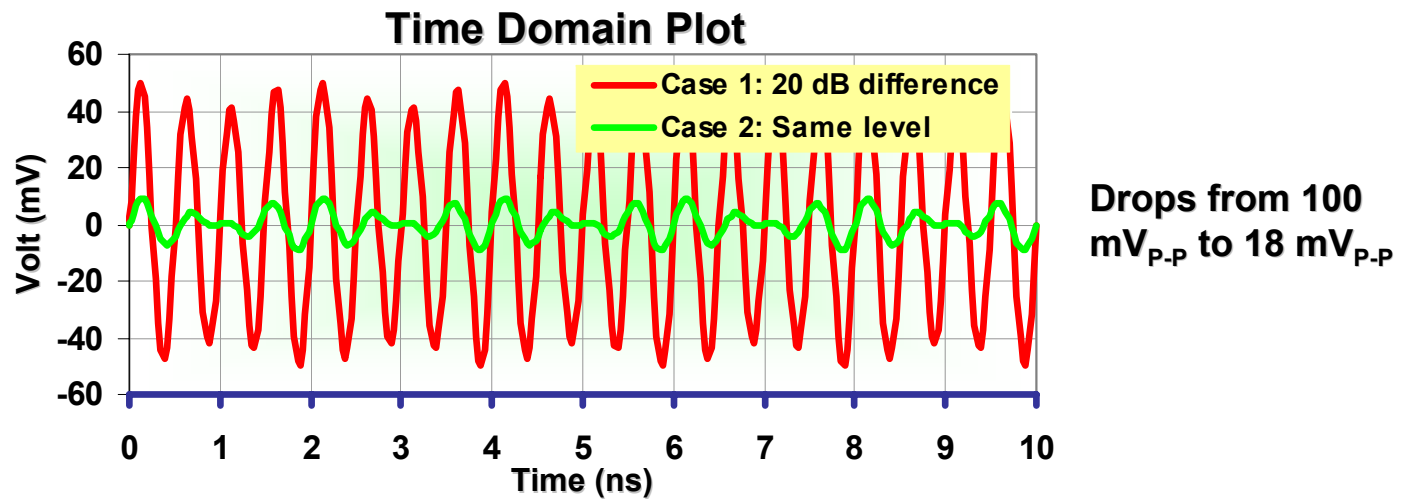
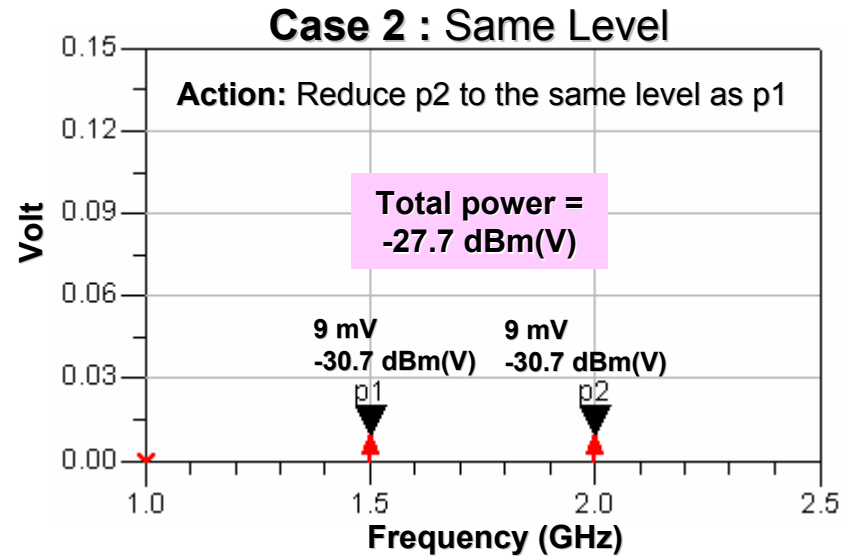
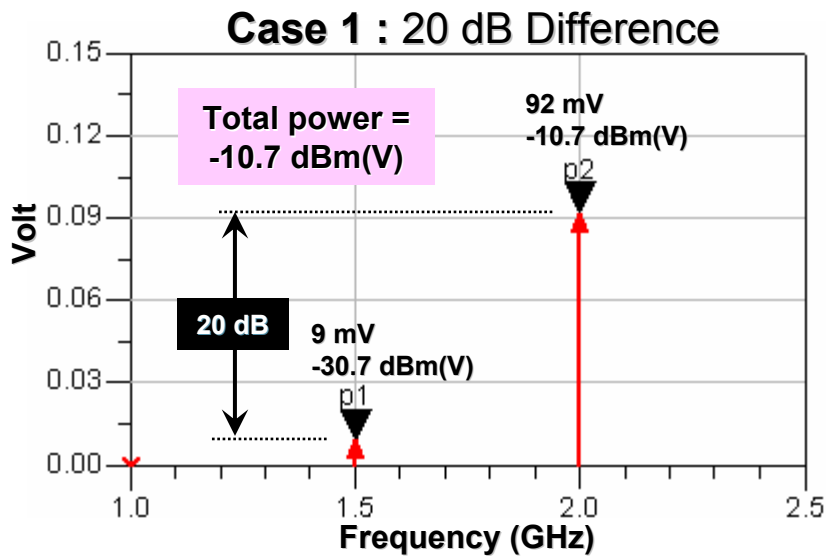

# Transmitted Waveform Rejection of Upper Sideband

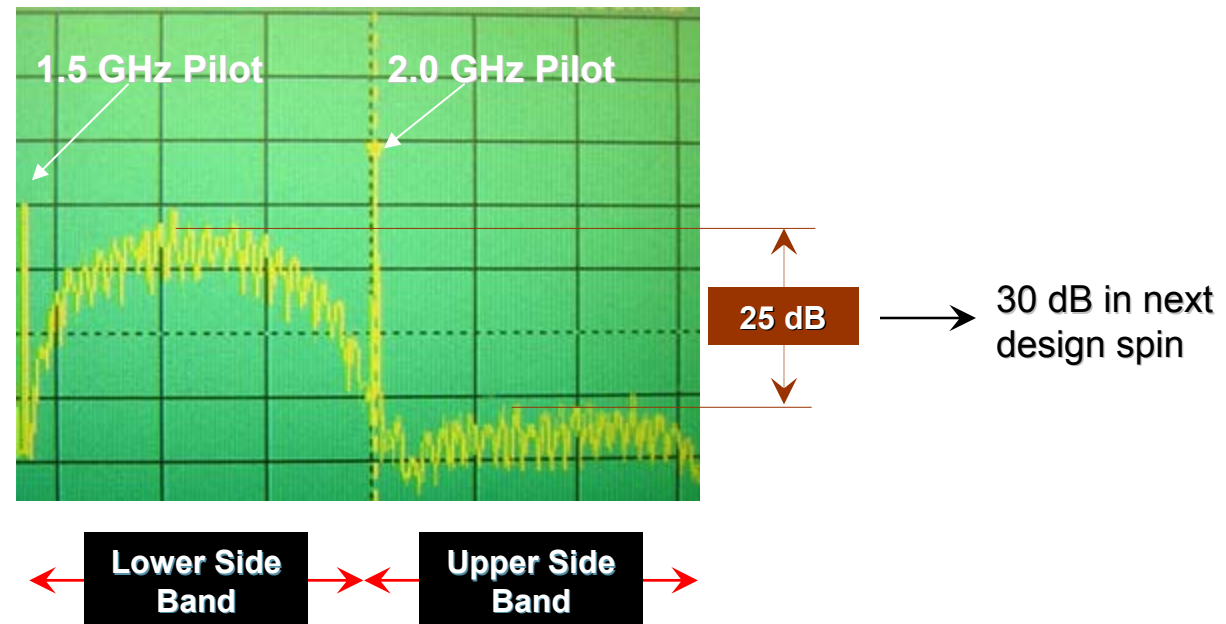

## Note

- Waveform at the output of Tx base band bit pipe
- Lower side band block upconverted to 60 GHz
- Existing 60 GHz millimeter wave transceiver based on GaAs devices

# Interference of Pilot Tones

## Assumptions & Analysis

### Question

Can pilots from adjoining channel interfere?

### Assumption

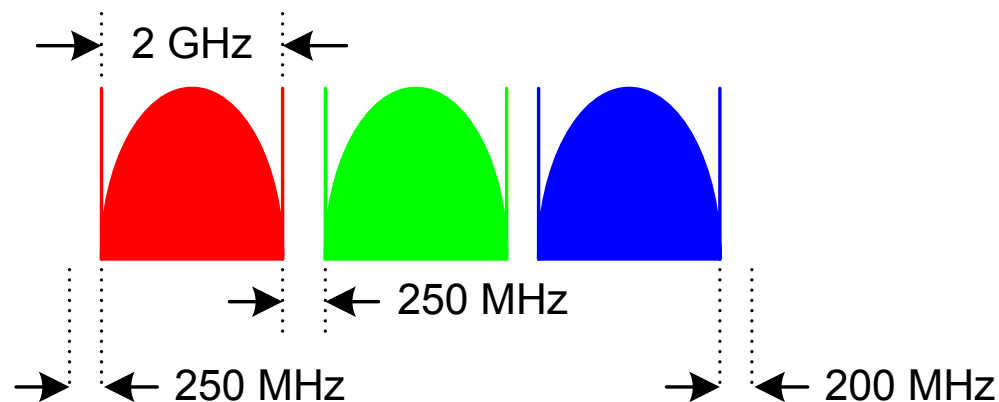

- Dependent on base band implementation – several options available
- Closest an interfering pilot comes to the actual one is 250 MHz

# Decoding

- *Partial response maximum likelihood* decoding
- Proven technology – used in disk drives
- Existing prototype
  - Partial response implemented
  - Maximum likelihood not implemented in current design (500 MHz, 1 Gbps) – will implement in next design spin (1 GHz, 2 Gbps)
- Maximum likelihood provides SNR gain of 2 dB
- All implementation in analog domain



# Modem Features

- Design that focuses on low cost, high speed and low power
- Flexible architecture – any digital input, with or without coding
- Spectral efficiency of 2 bps/Hz at 25% roll off
- Performance comparable to 2-level PAM
- No DACs or DSPs
- Low power, low latency
- Can operate at 1 dB compression point
- Relatively immune to phase noise and frequency errors at 60 GHz
- Fast data recovery (~100 ns)
- Fast AGC (40 dB dynamic range, 1% of actual value in ~10  $\mu$ s)
- Fixed data rate and modulation – translates to simplicity
- Up to 12 Gbps

Due to pilot tones

# Migration Path

- Current design supports all applications in the usage model and beyond
  - 4 Gbps [2 GHz/channel] will meet most immediate applications
  - [2 GHz/channel] . [3 channels] . [2 bps/Hz] = 12 Gbps
- Two techniques to increase data rate
  - Channel bonding
    - Low power consumption, low complexity
    - Margin drops by 3 dB per channel bonding
  - Base band stacking
    - Maintains margin
    - Power consumption doubles, adds complexity

# Channel Model Environments

#	Environment	Tx	Rx	Measurement & Analysis	Comments
CM1.2	Residential, LOS	60°	15°	NICT	Simulation based on 30° Rx
CM1.3	Residential, LOS	30°	15°	NICT	<ul style="list-style-type: none"><li>▪ Simulation based on 30° Rx</li><li>▪ AWGN channel</li></ul>

# BER Plot

## CM1.2, Tx 30° ► Rx 30°

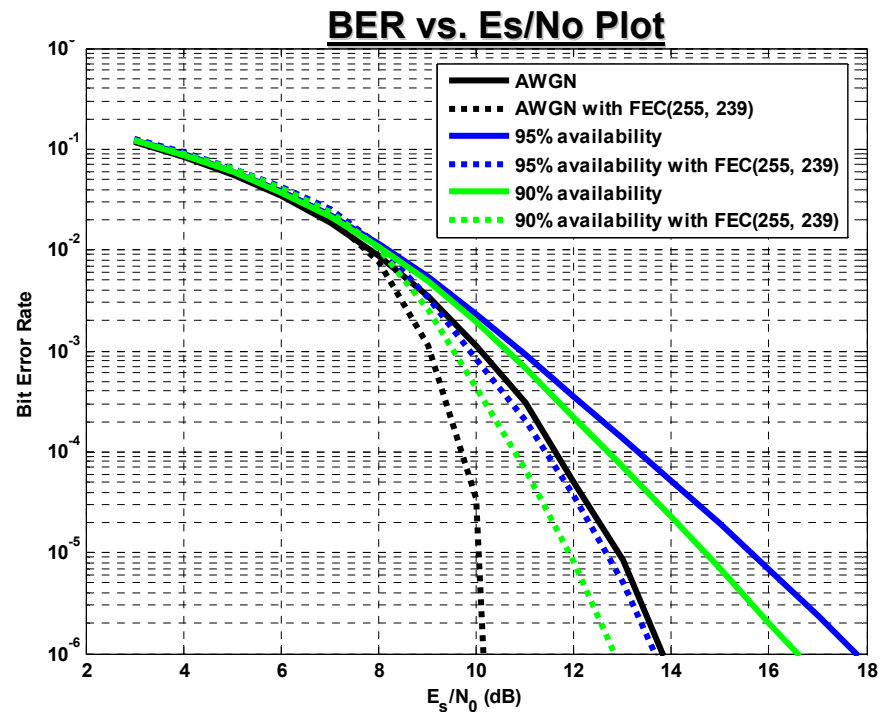
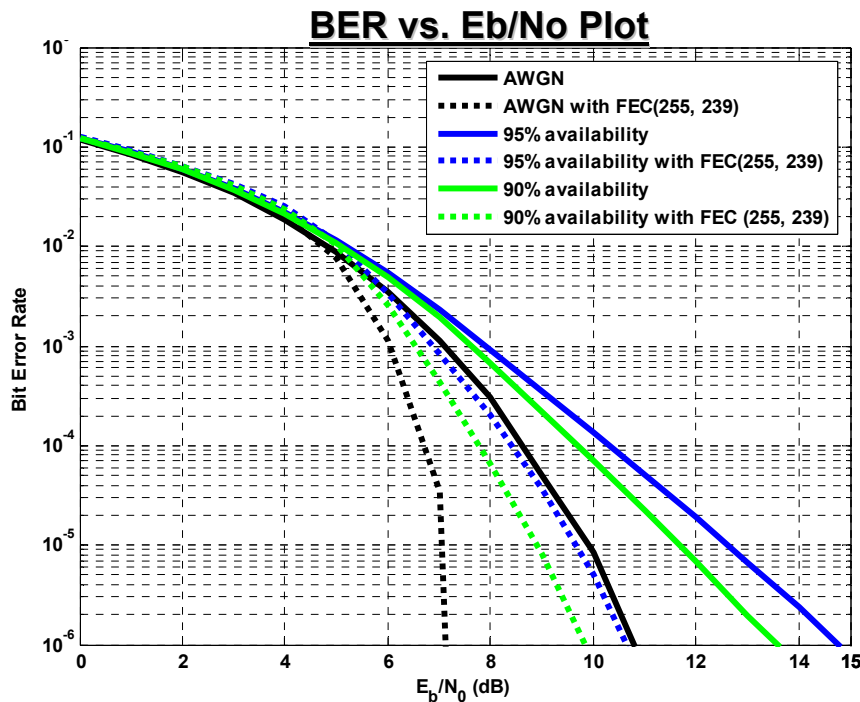

- Linear polarization
- No equalization
- BER  $10^{-6}$  (without FEC)
  - $E_b/N_0$  of 11 dB for AWGN
  - $E_b/N_0$  of 15 dB for 95% availability

**Comment**

Performance can be improved by about 2 dB by considering circular polarization for LOS applications

# Link Analysis

## Portable Applications [3 m, 4 Gbps]

### AWGN

Power in antenna (at 1 dB CP)	-3.1 dBm
Tx antenna gain [30°]	14.9 dBi
Radiated power	11.8 dBm
Free space loss at 3.0 m	77.6 dB
Gaseous attenuation	0.0 dB
Miscellaneous loss	0.0 dB
Attenuation	77.7 dB
Rx antenna gain [30°]	14.9 dBi
Effective power into receiver	-51.0 dBm
KTB [2000 MHz, 290 K]	-81.0 dBm
Receiver noise figure	8.0 dB
Eb/No [ BER 10-6]	11.0 dB
FEC gain	0.0 dB
Jitter	1.0 dB
Receiver sensitivity	-61.0 dBm
Margin	10.0 dB

### CM1.2 Environment

Power in antenna (at 1 dB CP)	0.9 dBm
Tx antenna gain [30°]	14.9 dBi
Radiated power	15.8 dBm
Free space loss at 3.0 m	77.6 dB
Gaseous attenuation	0.0 dB
Miscellaneous loss	0.0 dB
Attenuation	77.7 dB
Rx antenna gain [30°]	14.9 dBi
Effective power into receiver	-47.0 dBm
KTB [2000 MHz, 290 K]	-81.0 dBm
Receiver noise figure	8.0 dB
Eb/No [ BER 10-6, 95% availability]	15.0 dB
FEC gain	0.0 dB
Jitter	1.0 dB
Receiver sensitivity	-57.0 dBm
Margin	10.0 dB

**Note:** No FEC or equalization

# Link Analysis

## Portable Applications [3 m, 4 Gbps]

### Power (dBm) Into Antenna Versus Margin

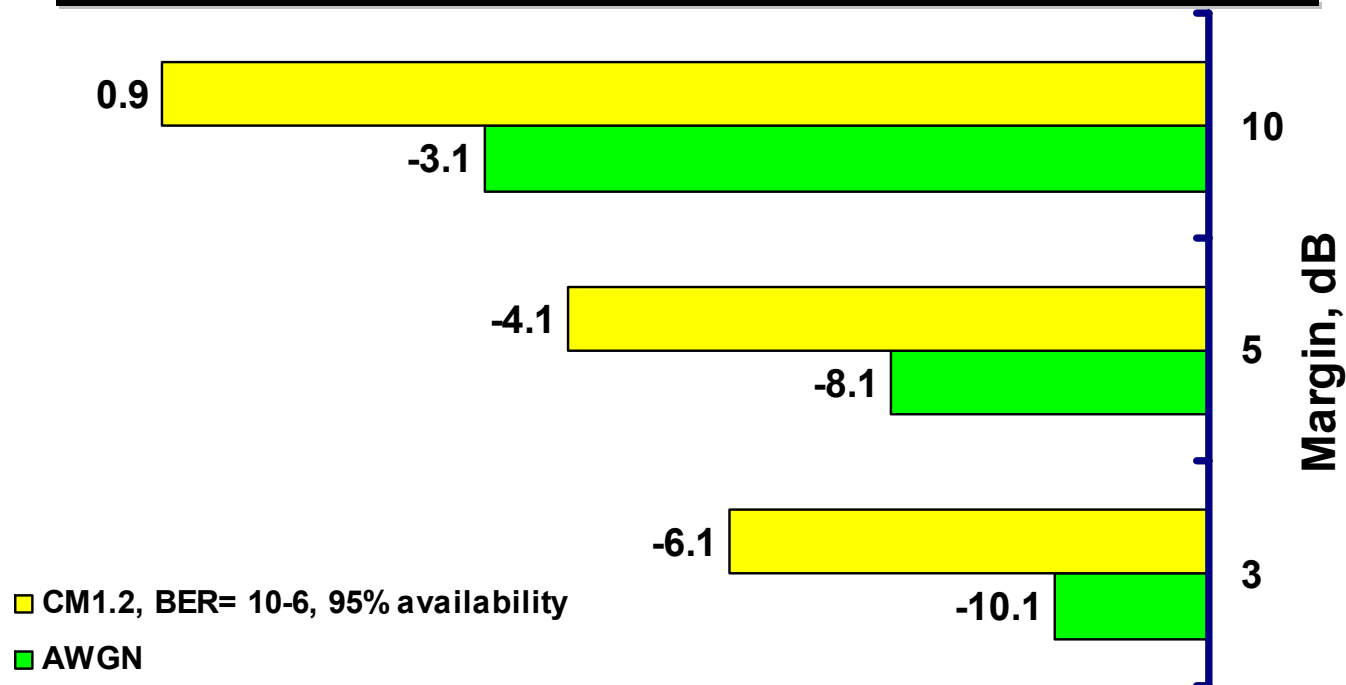

#### Note

- Refer to the previous slide for details on receiver sensitivity
- Add about 2 dB for insertion loss in SP2T switch to determine power out of 60 GHz amplifier

# Link Analysis

## Fixed Application [10 m, 4 Gbps]

### AWGN

Power in antenna (at 1 dB CP)	10.0 dBm
Tx antenna gain [30°]	14.9 dBi
Radiated power	24.9 dBm
Free space loss at 10.0 m	88.1 dB
Gaseous attenuation	0.2 dB
Miscellaneous loss	0.0 dB
Attenuation	88.2 dB
Rx antenna gain [30°]	14.9 dBi
Effective power into receiver	-48.4 dBm
KTB [2000 MHz, 290 K]	-81.0 dBm
Receiver noise figure	8.0 dB
Eb/No [ BER 10-6, 95% availability]	11.0 dB
FEC gain	0.0 dB
Jitter	1.0 dB
Receiver sensitivity	-61.0 dBm
Margin	12.5 dB

### CM1.2 Environment

Power in antenna (at 1 dB CP)	10.0 dBm
Tx antenna gain [30°]	14.9 dBi
Radiated power	24.9 dBm
Free space loss at 10.0 m	88.1 dB
Gaseous attenuation	0.2 dB
Miscellaneous loss	0.0 dB
Attenuation	88.2 dB
Rx antenna gain [30°]	14.9 dBi
Effective power into receiver	-48.4 dBm
KTB [2000 MHz, 290 K]	-81.0 dBm
Receiver noise figure	8.0 dB
Eb/No [ BER 10-6, 95% availability]	15.0 dB
FEC gain	0.0 dB
Jitter	1.0 dB
Receiver sensitivity	-57.0 dBm
Margin	8.5 dB

**Note:** No FEC or equalization

Require  $\geq 20$  dB margin for AGC to operate to mitigate shadowing effects

# Link Analysis - Modified Fixed [10 m, 4 Gbps]

## Increased Antenna Gain

Power in antenna (at 1 dB CP)	10.0 dBm
<b>Tx antenna gain [15°]</b>	<b>21.0 dBi</b>
Radiated power	31.0 dBm
Free space loss at 10.0 m	88.1 dB
Gaseous attenuation	0.2 dB
Miscellaneous loss	0.0 dB
Attenuation	88.2 dB
<b>Rx antenna gain [15°]</b>	<b>21.0 dBi</b>
Effective power into receiver	-36.2 dBm
KTB [2000 MHz, 290 K]	-81.0 dBm
Receiver noise figure	8.0 dB
Eb/No [ BER 10-6, 95% availability]	15.0 dB
FEC gain	0.0 dB
Jitter	1.0 dB
Receiver sensitivity	-57.0 dBm
Margin	20.7 dB

## Increased Antenna Gain + FEC

Power in antenna (at 1 dB CP)	10.0 dBm
<b>Tx antenna gain [15°]</b>	<b>21.0 dBi</b>
Radiated power	31.0 dBm
Free space loss at 10.0 m	88.1 dB
Gaseous attenuation	0.2 dB
Miscellaneous loss	0.0 dB
Attenuation	88.2 dB
<b>Rx antenna gain [15°]</b>	<b>21.0 dBi</b>
Effective power into receiver	-36.2 dBm
KTB [2000 MHz, 290 K]	-81.0 dBm
Receiver noise figure	8.0 dB
Eb/No [ BER 10-6, 95% availability]	15.0 dB
<b>FEC gain</b>	<b>4.0 dB</b>
Jitter	1.0 dB
Receiver sensitivity	-61.0 dBm
Margin	24.7 dB

**Note:** No equalization



# Estimated Power Consumption Block Diagram & Assumptions

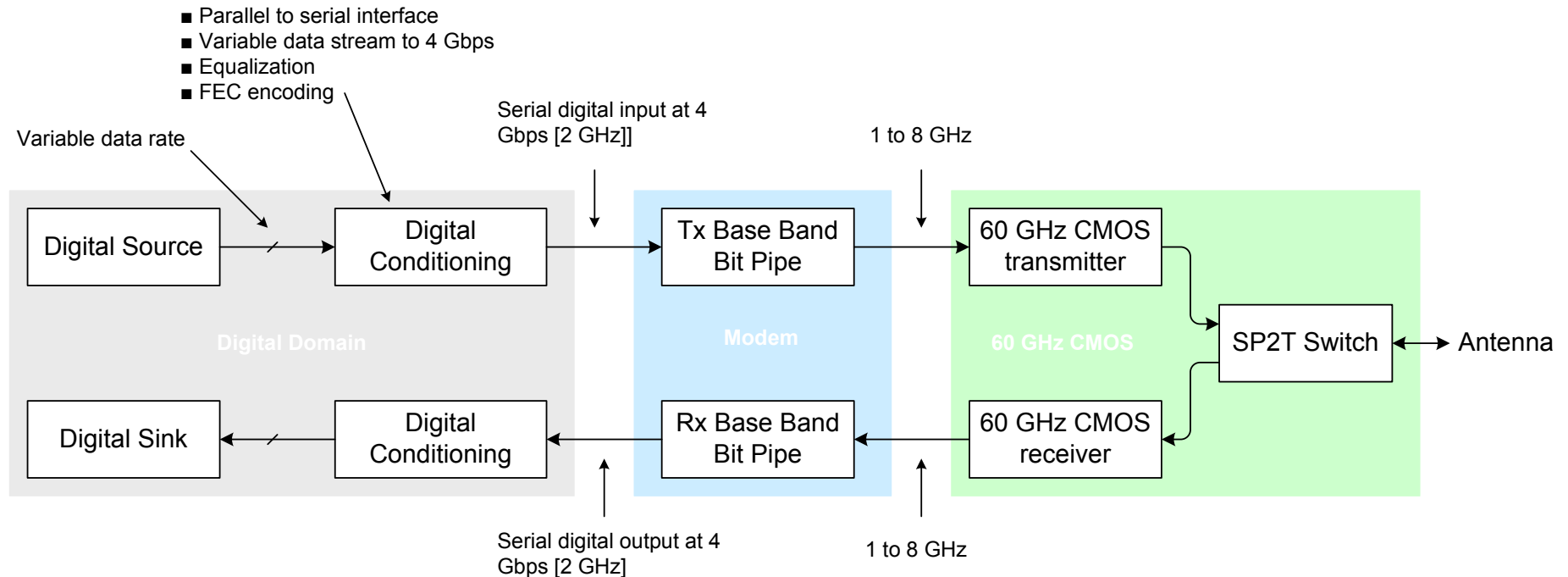

## Base Band Bit Pipe

- Based on existing prototypes with off-the-self components
- No sharing of functionality between Tx and Rx band bit pipe modules
- 130 nm CMOS implementation

## 60 GHz CMOS

- 100 mW maximum for 60 GHz output power of 5 dBm maximum

# Estimated Power Consumption

## Case A

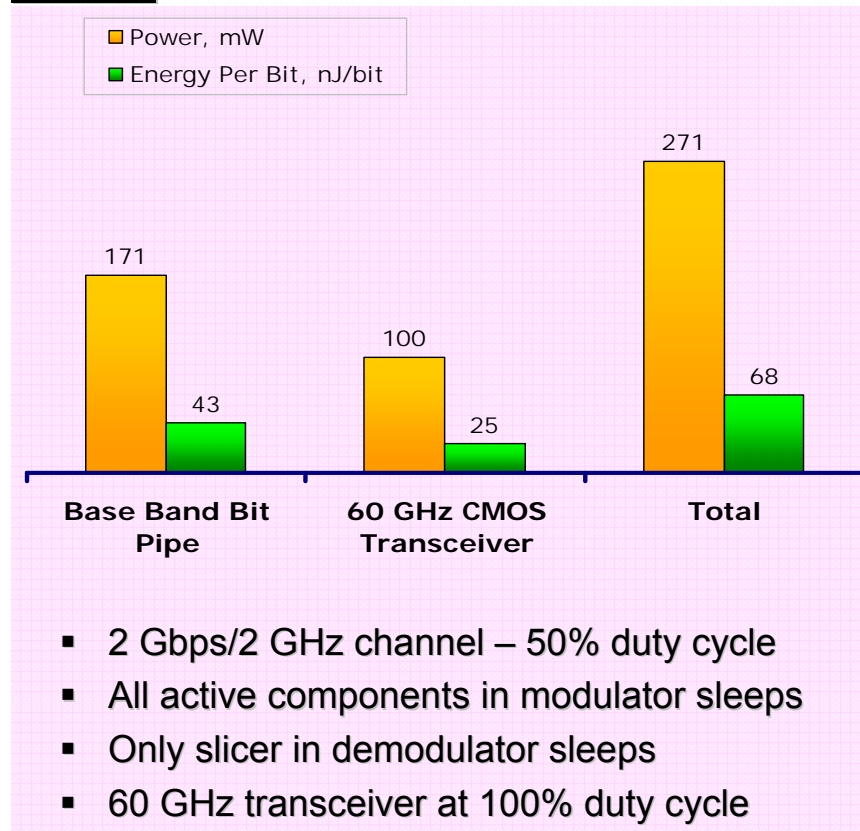

## Case B

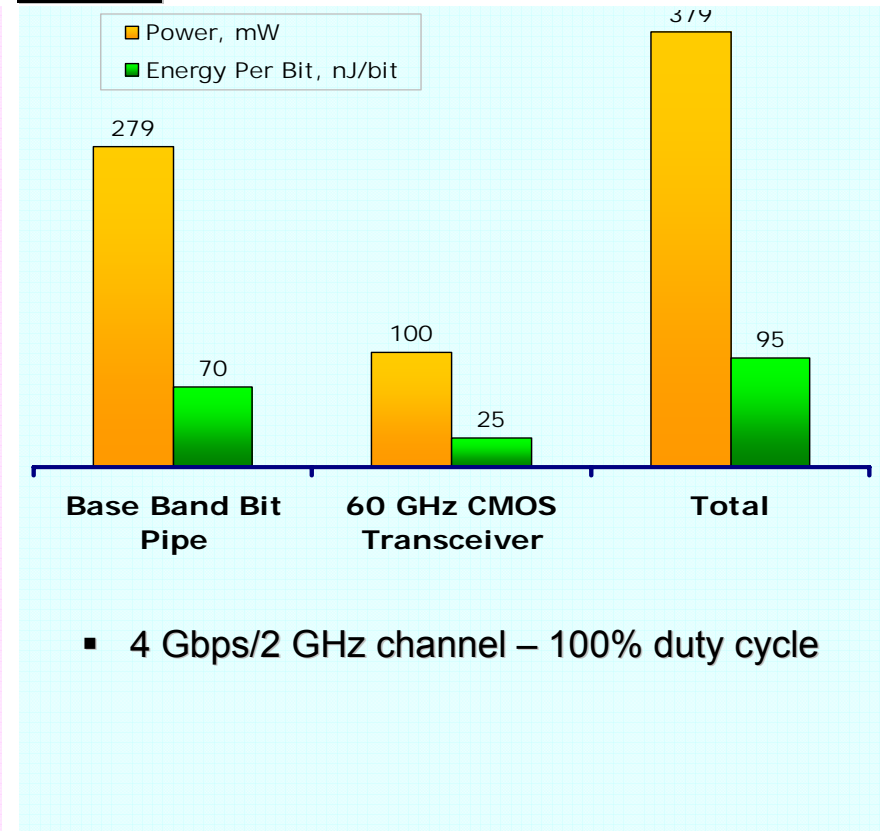

# Conclusion

- Out-of-the-box design optimized for high data rate, low power consumption, flexibility, fast clock recovery and AGC
- Flexibility in design
  - Current design based on analog signal processing
  - Incorporate DACs and DSPs when they mature
- Proven hardware implementation