

Project: IEEE P802.15 Working Group for Wireless Personal Area Networks (WPANs)

Submission Title: [An MSK system for Mobile Multi-Gb/s at 60GHz, concept, application and implementation]

Date Submitted: [17 September, 2006]

Source: [Troy Beukema, Brian Gaucher, Yasunao Katayama, Scott Reynolds, Alberto Valdes-Garcia]
Company [IBM Research]

Address [1101 Kitchawan Rd. Rte. 134, MS:30-116]

Voice:[+914-945-2596], E-Mail:[bgaucher@us.ibm.com]

Re: [Request of contributions for the 802.15.3c subgroup]

Abstract: [Design considerations and preliminary results of an MSK-based system for Multi-GB/s communications at 60GHz over a band limited directional channel, suitable for ‘MAC-less’ systems, MP3 player/HD synchronization applications...]

Purpose: [For discussion only]

Notice: This document has been prepared to assist the IEEE P802.15. It is offered as a basis for discussion and is not binding on the contributing individual(s) or organization(s). The material in this document is subject to change in form and content after further study. The contributor(s) reserve(s) the right to add, amend or withdraw material contained herein.

Release: The contributor acknowledges and accepts that this contribution becomes the property of IEEE and may be made publicly available by P802.15.

Outline

- **Applications for a 60GHz directional channel.**
- **Principles of MSK modulation.**
- **Performance and effects of band limitation.**
- **Integrated MSK modulator and measurement results.**
- **Summary.**

Tiered standard needed:

- **‘Simple’ multi-Gbps portable applications require low complexity, low power, low cost solutions: e.g. Directional, single carrier link**
 - Kiosk applications
 - Synchronization (MP3 Players, HDs, iPODs...)
 - Point-point links (Campus, HDMI...)
- **‘More complex’ multi-Gbps less portable applications can afford higher complexity, power and cost solutions: e.g. Omni-directional, multi-carrier network**
 - WPAN
 - High definition video system network

Ex. Applications for 60GHz Systems

No-MAC Wireless Point-to-Point Cable : e.g. One-way uncompressed video, Kiosk, MP3 Player or HD sync...

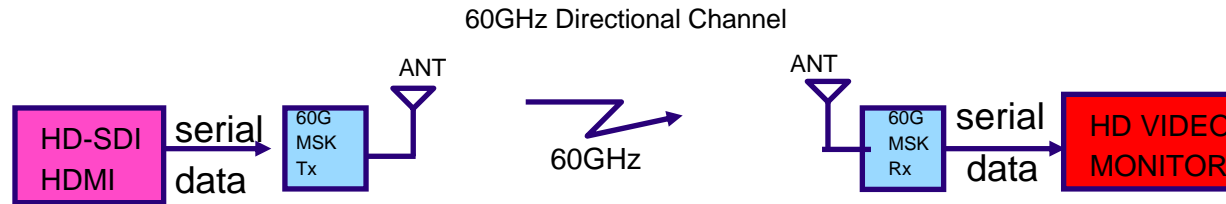

e.g. Half-Duplex Ethernet Mac for Wireless Point-to-Point 2Gb/s “Point and Shoot” Ethernet

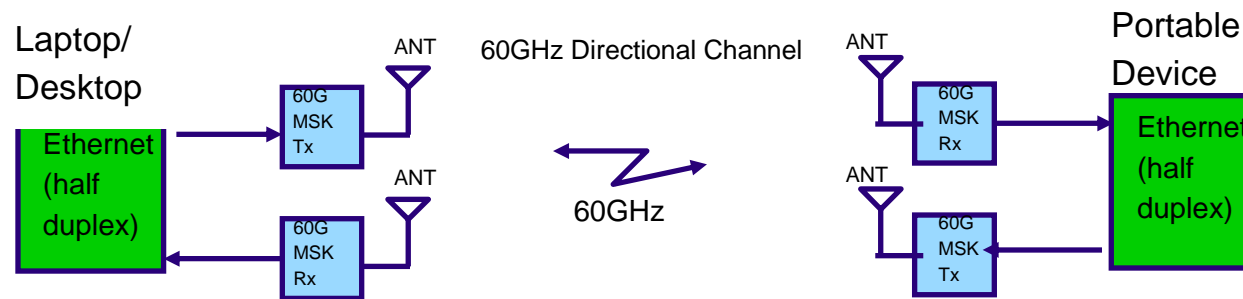

e.g. Full-Duplex Ethernet Mac for 1Gb/s Wireless Point-to-Point Ethernet Bridges

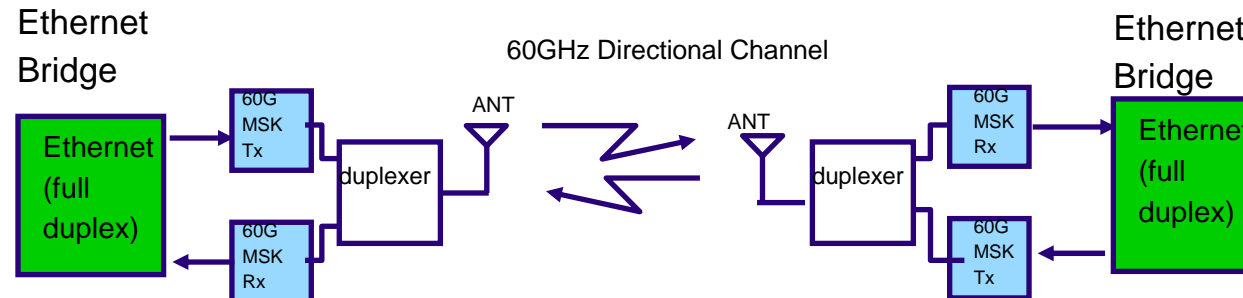

MSK Modulation Overview

MSK can be described as phase-continuous 2-level FM with deviation = $R/4$ where R = data rate.

The frequency is allowed to change polarity on quadrant boundaries only.

MSK data encoding :

1 bit : freq = $+R/4$

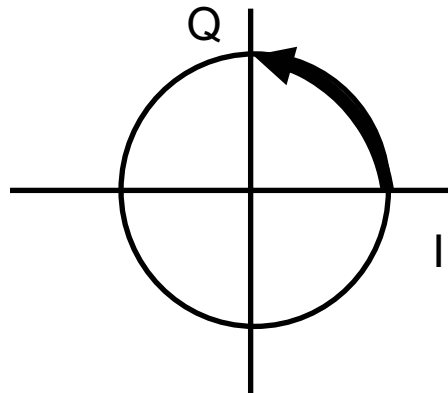

0 bit : freq = $-R/4$

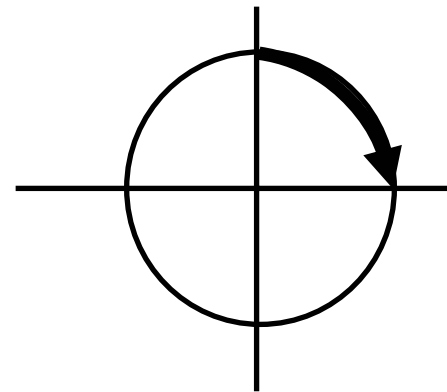

Frequency changes at phase= 0, $\pi/2$, π , and $3\pi/2$ radians only

Example MSK Generation

MSK can be generated by modulating the signs of half-sine pulses separated by 90 degrees on I and Q axes.

A sine pulse sign is encoded with a data bit corresponding to the first half of the pulse in time duration.

To encode + Frequency (1) data bit value :

- on Q pulse : Q pulse sign = I pulse sign over bit interval
- on I pulse : I pulse sign = opposite of Q pulse sign over bit interval

To encode - Frequency (0) data bit value :

- on Q pulse : Q pulse sign = opposite of I pulse sign
- on I pulse : I pulse sign = Q pulse sign

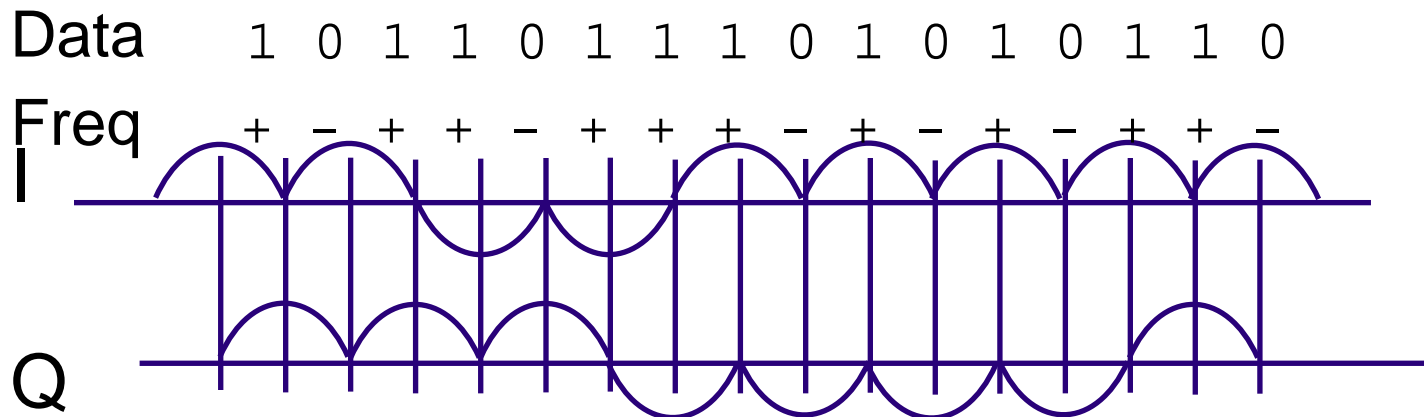
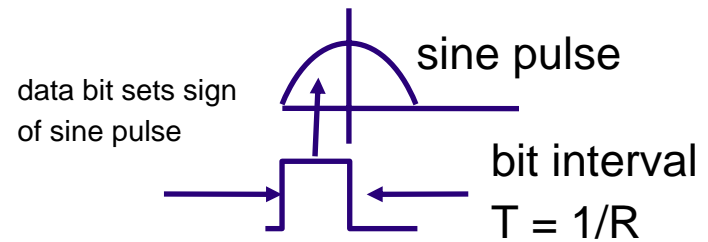

MSK Demodulation

MSK can be demodulated using a FM limiter/discriminator + CDR for low power/low complexity, or with conventional A/D + DSP for higher power/higher complexity and better sensitivity.

FM Discriminator/CDR approach :

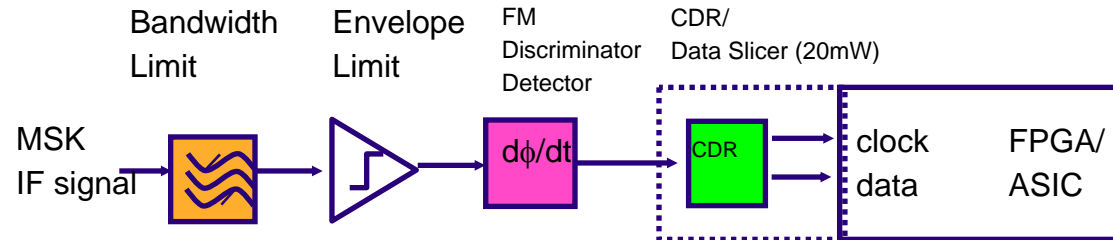

A/D + DSP approach (~3dB better sensitivity; can also add channel equalization)

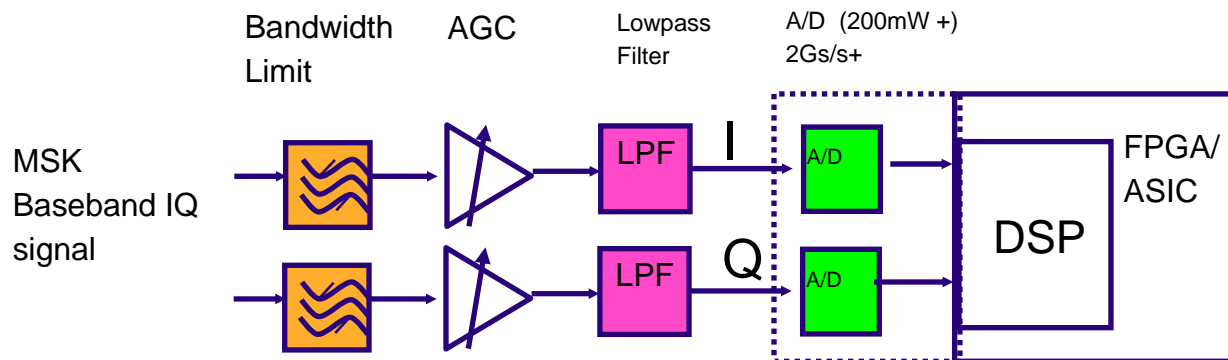

MSK AWGN Sensitivity

FM limiter/Discriminator P_b is shown below: 15dB SNR is needed for low error rate ($1e-5$) operation. The addition of a RS(255,239) code improves sensitivity to ~11dB SNR for length 1912 bit payload.

MSK FM Discriminator AWGN BER Sensitivity

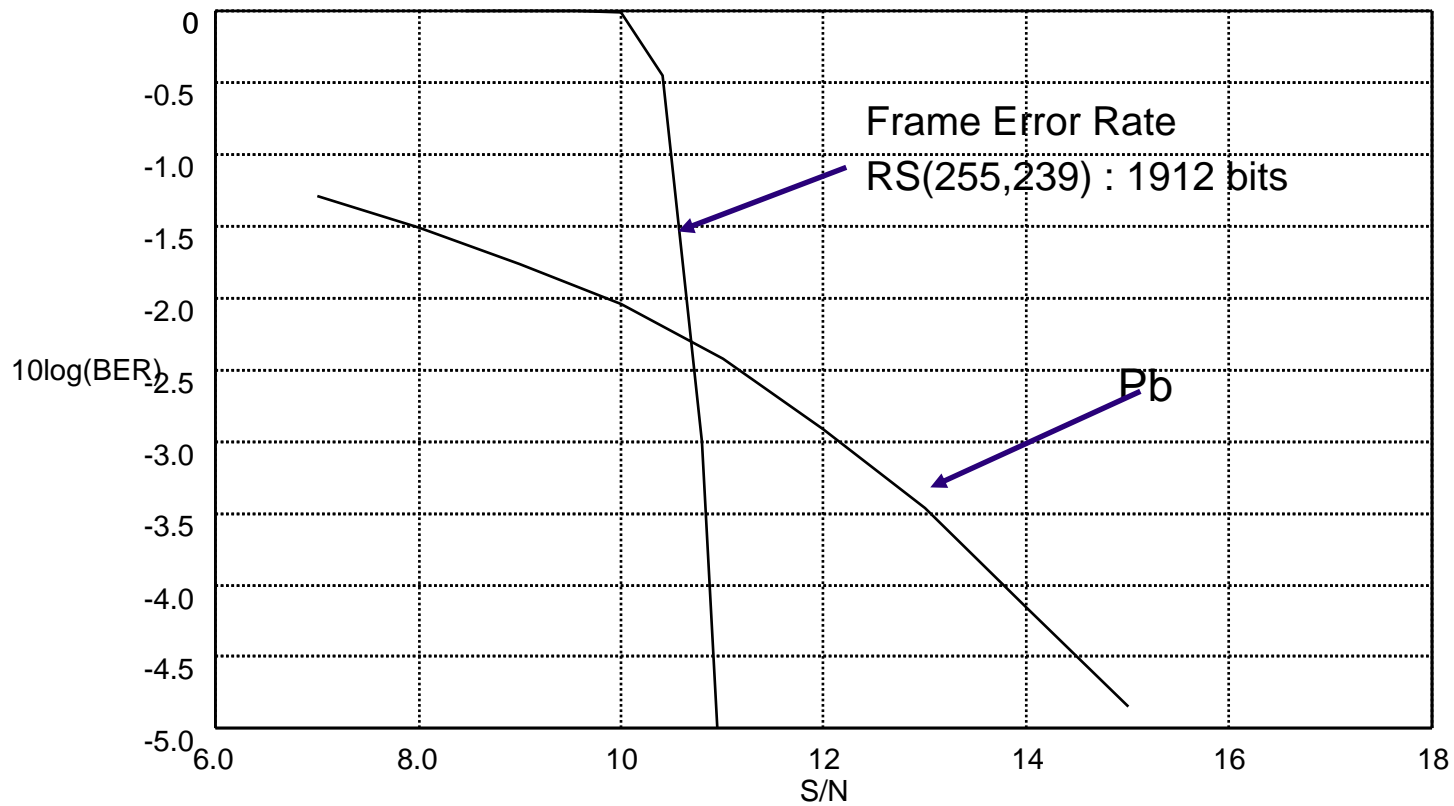

60GHz Bandwidth Limited MSK Modulation System (Simulation)

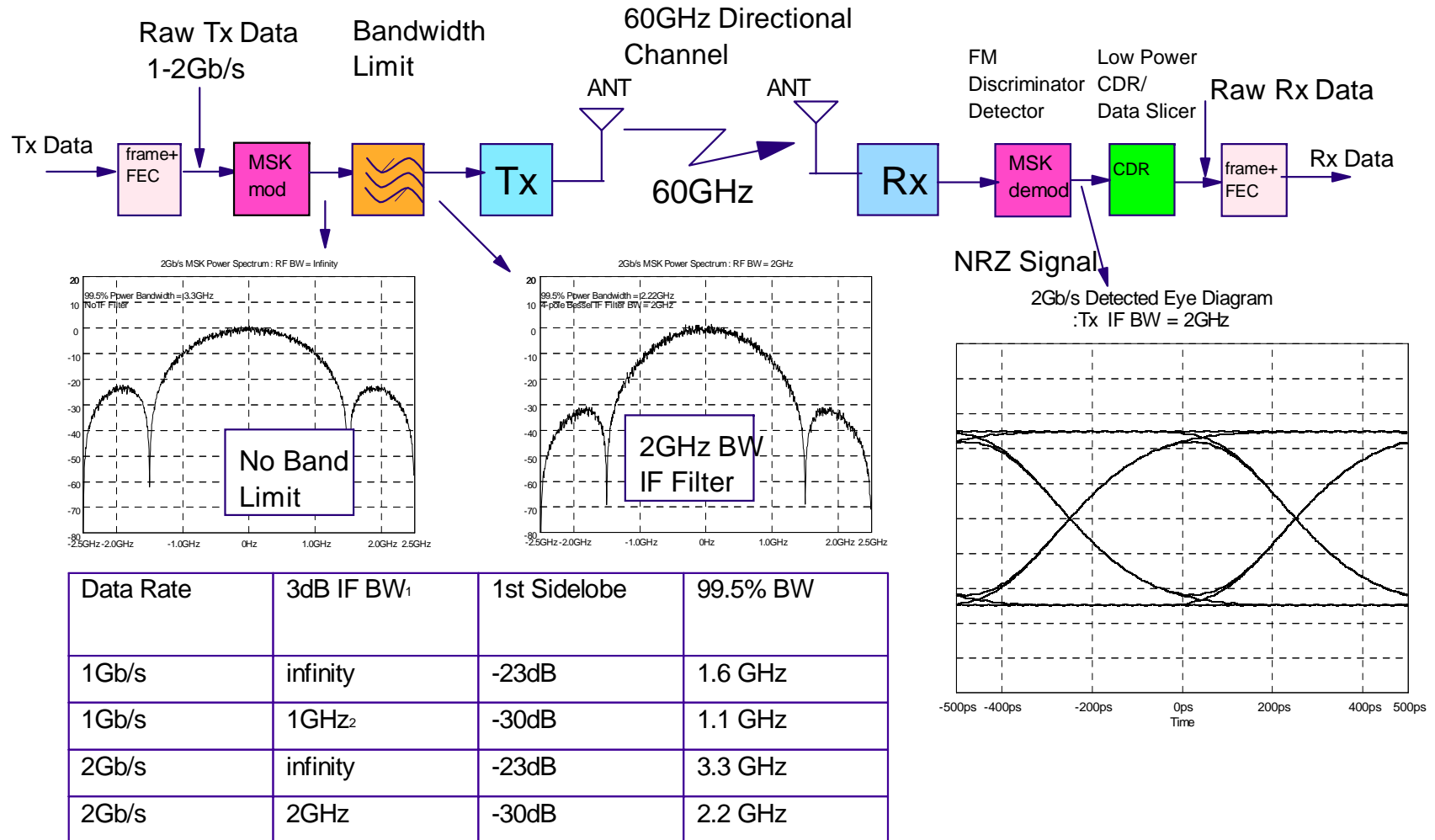

Integrated MSK Modulator

- **The prototype IC incorporates:**
 - MSK modulator
 - IF up-conversion mixer
 - Active IF filter.
- **Designed to support multi-Gbps data rates**
- **Compact implementation for 60GHz transmitter**

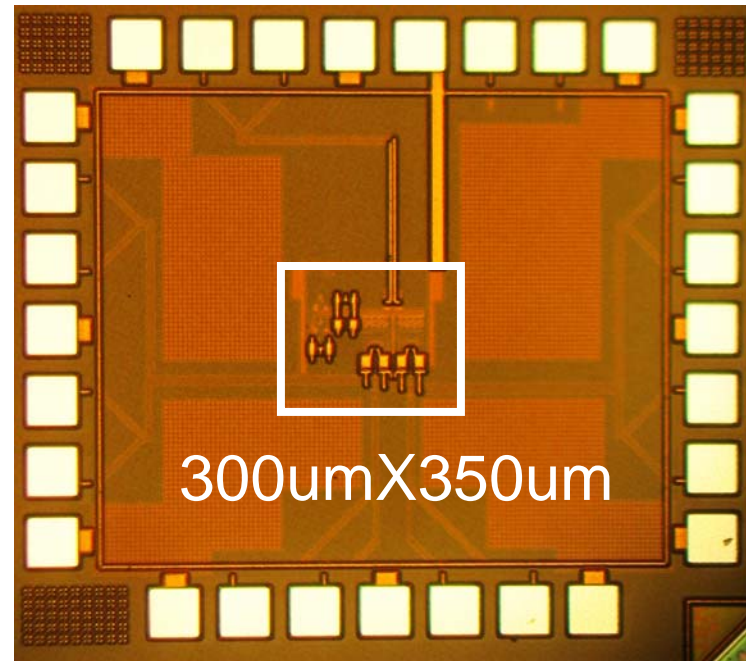

MSK modulator measurement results

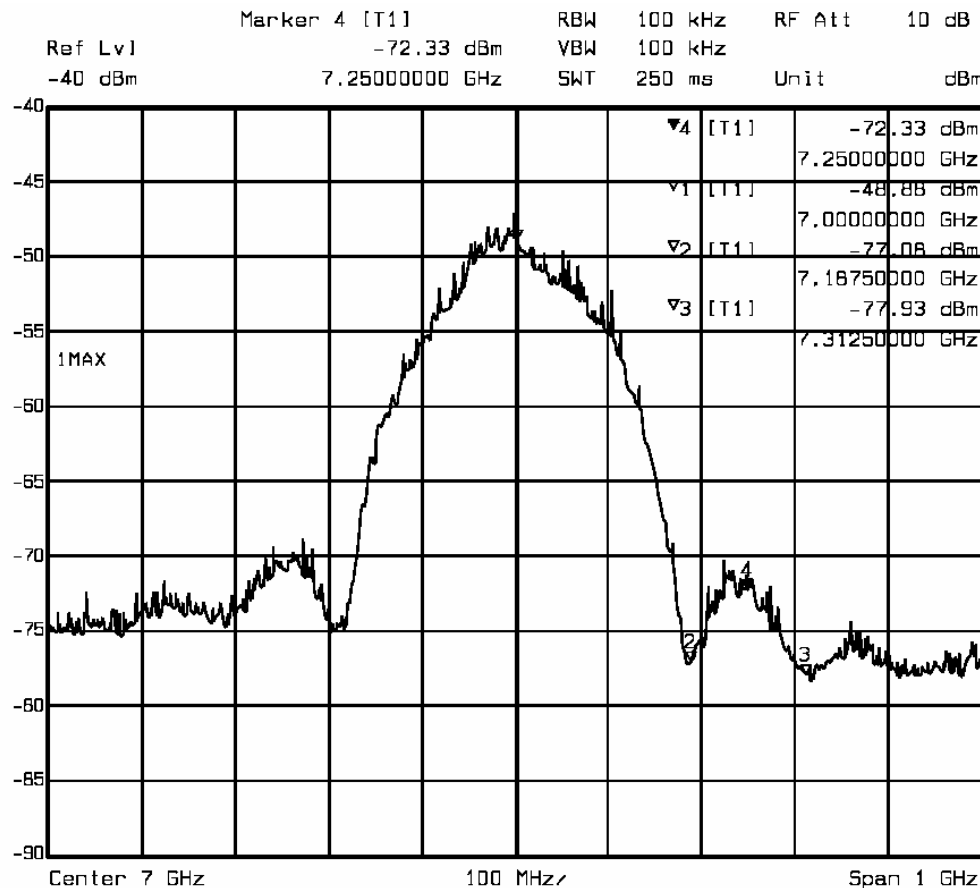

- First test results at moderate speeds confirm proof of concept.
- 250MB/s IF (7GHz) MSK spectrum in good agreement with theory.
- IF filter BW ~2GHz, side-lobe suppression is due to modulation only.

Summary

- **An MSK-based system for multi-Gb/s comm. at 60GHz presents significant advantages (i.e. lower complexity and power consumption) in a directional channel.**
- **An FSK detector has been characterized in 60GHz RX.**
- **An integrated MSK modulator has been demonstrated.**
- **A full TX and RX with MSK mod/demod have been fabricated, characterization for a high data rate link will follow.**
- **This work supports the lower power, lower complexity, lower cost directional link systems.**