

**Project: IEEE P802.15 Working Group for Wireless Personal Area Networks (WPANs)**

**Submission Title:** [Merged Proposal of Chaotic UWB System for 802.15.4a]

**Date Submitted:** [March 7, 2005]

**Source:** [(1) Young-Hwan Kim, Jae-Hyon Kim, Chia-Chin Chong, Su Khiong Yong, Seong-Soo Lee, (2) Hyung Soo Lee, Cheol Hyo Lee, (3) Jeongsuk Lee, (4) Namhyong Kim, (5) Kyung Sup Kwak, (6) A. S. Dmitriev, A. I. Panas, S. O. Starkov, Yu. V. Andreyev, E. V. Efremova, L. V. Kuzmin, (7) Haksun Kim, (8) Jaesang Cha, (9) Dong Jo Park, Dan Keun Sung, Sung Yoon Jung, Chang Yong Jung, (10) Joon Yong Lee, (11) Dong In Kim, Serhat Erküçük]

**Company:** [(1) Samsung Electronics Co., Ltd. (Samsung Advanced Institute of Technology (SAIT)), (2) Electronics and Telecommunications Research Institute (ETRI), (3) Samsung Electro-Mechanics Co., Ltd. (SEM), (4) Samsung Electronics (DM), (5) UWB-ITRC, Inha University, (6) Institute of Radio Engineering and Electronics (IRE), (7) Hanbat Univ., (8) Seokyeong Univ., (9) Korea Advanced Institute of Science and Technologies (KAIST), (10) Handong Global University (HGU), (11) Simon Fraser University]

**E-Mail:** [(1) jae.kim@samsung.com, (2) clee7@etri.re.kr, (3) js0305.lee@samsung.com, (4) namhyong.kim@samsung.com, (5) kskwak@inha.ac.kr, (6) chaos@mail.cplire.ru, (7) hskim@hanbat.ac.kr, (8) chajs@skuniv.ac.kr, (9) syjung@kaist.ac.kr, (10) joonlee@handong.edu, (11) dikim@sfu.ca]

**Re:** [Response to IEEE 802.15.4a Call for Proposals (04/380r2)]

**Abstract:** [Proposal for the IEEE 802.15.4a PHY standard based on the chaotic UWB system technology.]

**Purpose:** [Proposal for the IEEE 802.15.4a PHY standard.]

**Notice:** This document has been prepared to assist the IEEE P802.15. It is offered as a basis for discussion and is not binding on the contributing individual(s) or organization(s). The material in this document is subject to change in form and content after further study. The contributor(s) reserve(s) the right to add, amend or withdraw material contained herein.

**Release:** The contributor acknowledges and accepts that this contribution becomes the property of IEEE and may be made publicly available by P802.15.

**Samsung Electronics (SAIT)/IRE/Samsung Electro-Mechanics(SEM),  
Samsung Electronics (DM),  
Electronics and Telecommunications Research Institute(ETRI)/KAIST/HGU,  
Simon Fraser University(SFU)/Inha University,**

## Chaotic UWB System

Young-Hwan Kim, Jae-Hyon Kim, Chia-Chin Chong, Su Khiong Yong, Seong-Soo Lee,  
A. S. Dmitriev, A. I. Panas, S. O. Starkov, Yu. V. Andreyev, E. V. Efremova, L. V. Kuzmin,  
Jeongsuk Lee, Haksun Kim, Jaesang Cha, Namhyong Kim, Haksun Kim, Jaesang Cha,  
Hyung Soo Lee, Cheol Hyo Lee, Dong Jo Park, Dan Keun Sung , Sung Yoon Jung,  
Chang Yong Jung, Joon Yong Lee, Dong In Kim, Serhat Erküçük, Kyung Sup Kwak

# CONTENTS

## 1. INTRODUCTION

## 2. CHAOTIC COMMUNICATION SYSTEM

## 3. GENERAL SOLUTION CRITERIA

- 3.1. Unit Manufacturing Cost/Complexity (UMC)
- 3.2. General Definitions
- 3.3. Signal Robustness
- 3.4. Technical Feasibility
- 3.5. Scalability

## 4. MAC PROTOCOL SUPPLEMENT

- 4.1 MAC Enhancements and Modifications

## 5. PHY LAYER CRITERIA

- 5.1. Channel models and payload data
- 5.2. Size and Form Factor
- 5.3. PHY-SAP Payload Bit Rate and Data Throughput
- 5.4. Simultaneously Operating Piconets
- 5.5. Signal Acquisition
- 5.6. System Performance
- 5.7. Ranging
- 5.8. Link Budget
- 5.9. Sensitivity
- 5.10. Power Management Modes
- 5.11. Power Consumption
- 5.12. Antenna Practicality

**Compatible Modulation Scheme: DCSK**

**Compatible Modulation Scheme: MC-PPM**

# 1. INTRODUCTION

## Features of Proposed System

- **Low Hardware Complexity / Low Cost**
  - Chaotic signal can be generated directly into the desired microwave band (Simple RF circuit)
- **Efficient Power Management**
  - Sleep / Wake-up capability can save the battery life time
- **Robust in Multipath**
  - In case of OOK Modulation, BER performance against multipath is close to the AWGN (only few dB difference)
- **Flexible Pulse Length**
  - Chaotic radio pulse can be transmitted with different pulse time duration regardless of the spectral bandwidth

## 2. CHAOTIC COMMUNICATION SYSTEM

### Chaotic Source

- Chaotic source generates oscillations directly in a specified microwave band.
- Information component is put into the chaotic carrier to form a stream of chaotic radio pulses.
- Information can be retrieved from the chaotic radio pulses without intermediate heterodyning.

Chaotic Source Generator Circuit

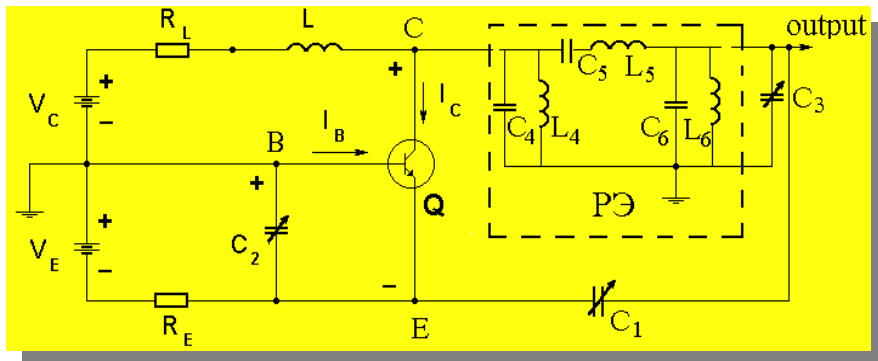

Experiment device

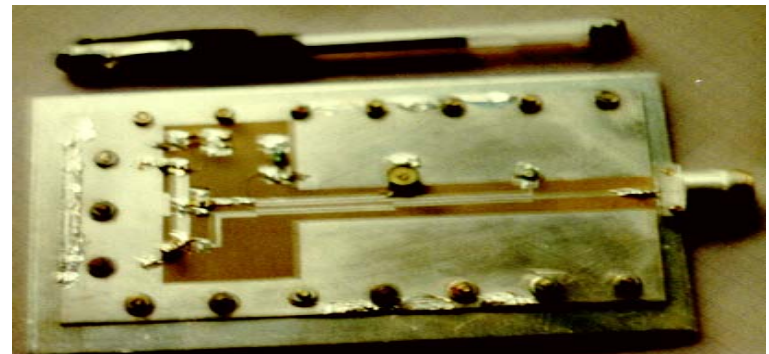

# 2. CHAOTIC COMMUNICATION SYSTEM

## Spectral Properties of Chaotic Signal

- Spectral properties don't change even though the length or duration of the chaotic pulses are varied

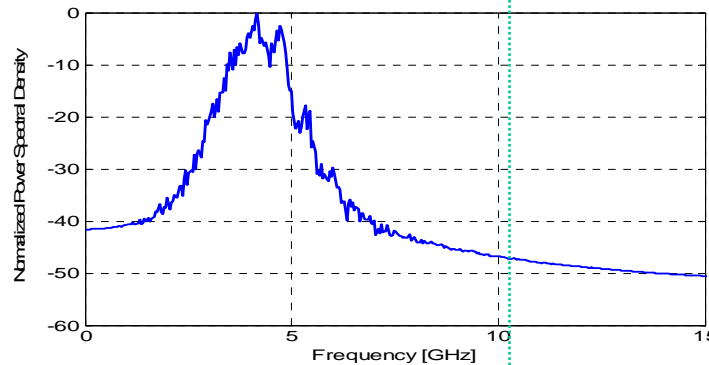
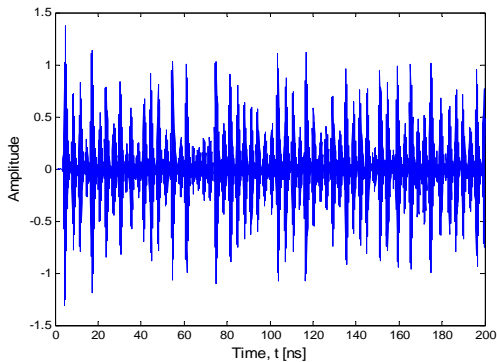

Chaotic Signal

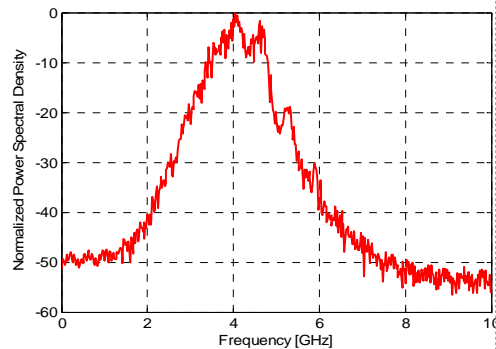
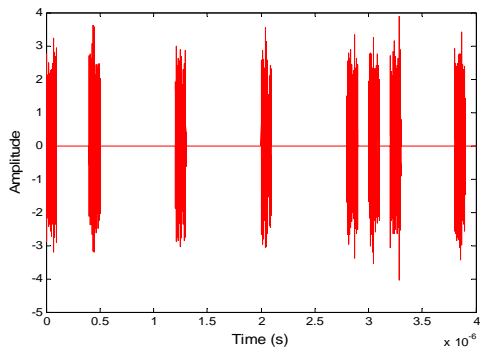

Chaotic Pulse (OOK)

## 2. CHAOTIC COMMUNICATION SYSTEM

### Modulation Schemes

#### ■ OOK (main modulation type)

- Advantages:
  - Lower **complexity ( TX and RX )**
  - 3 dB more **energy efficiency** than DCSK or PPM  
=> battery saving
- Disadvantages:
  - Requires **non-zero detection threshold**

#### ■ DCSK (compatible modulation type)

#### ■ PPM (compatible modulation type)

# 3.1. Unit Manufacturing Cost/Complexity

## Complexity (OOK)

- **RF part of the transceiver:**
  - Chaotic oscillator in 3.1-5.1 GHz frequency band with 10 dBm output power amplifier (common complexity is equivalent to 4 power amplifiers)
  - Switch-modulator
  - LNA (amplification 30-35 dB)
  - 2 Band Pass Filter with bandwidth 1 GHz (in band 3.1-5.1 GHz)
  - Envelope detector
  - Antennas
  - **No mixers, no correlators, no RF VCO**
- **Baseband part of the transceiver:**
  - Reference oscillator – 20 MHz
  - Bandpass amplifiers
  - Threshold detector or 4 bit A/D converter
  - Frequency Synthesizer on 2.002 MHz (for ranging)
  - **Digital part with ~ 10K gates**



## 3.4. Technical Feasibility

### Prototype 1

- The communication test has successfully done using Chaotic pulses

#### UWB DCC-OOK Test-bed



# 3.4. Technical Feasibility

## Prototype 2

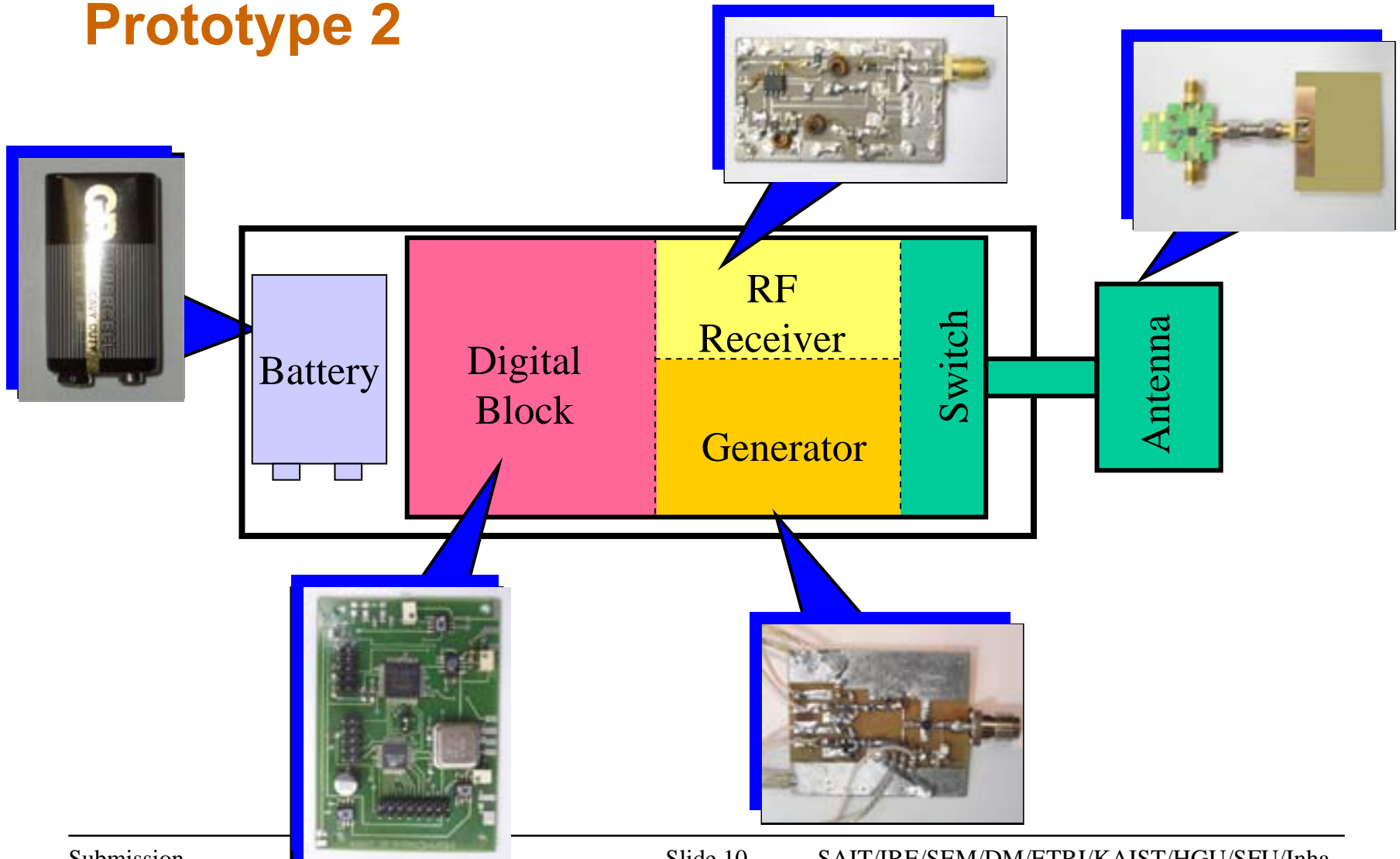

# 3.5. Scalability

## Chaotic Pulse Duration

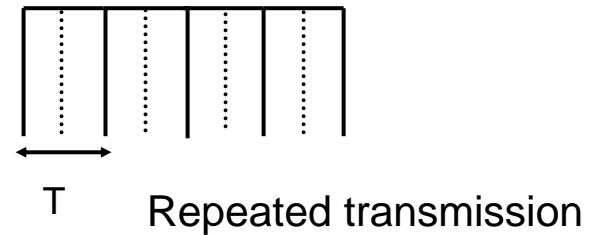
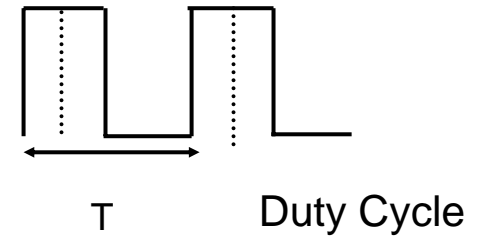
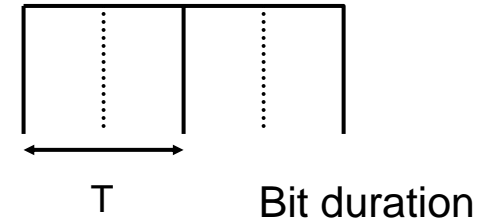
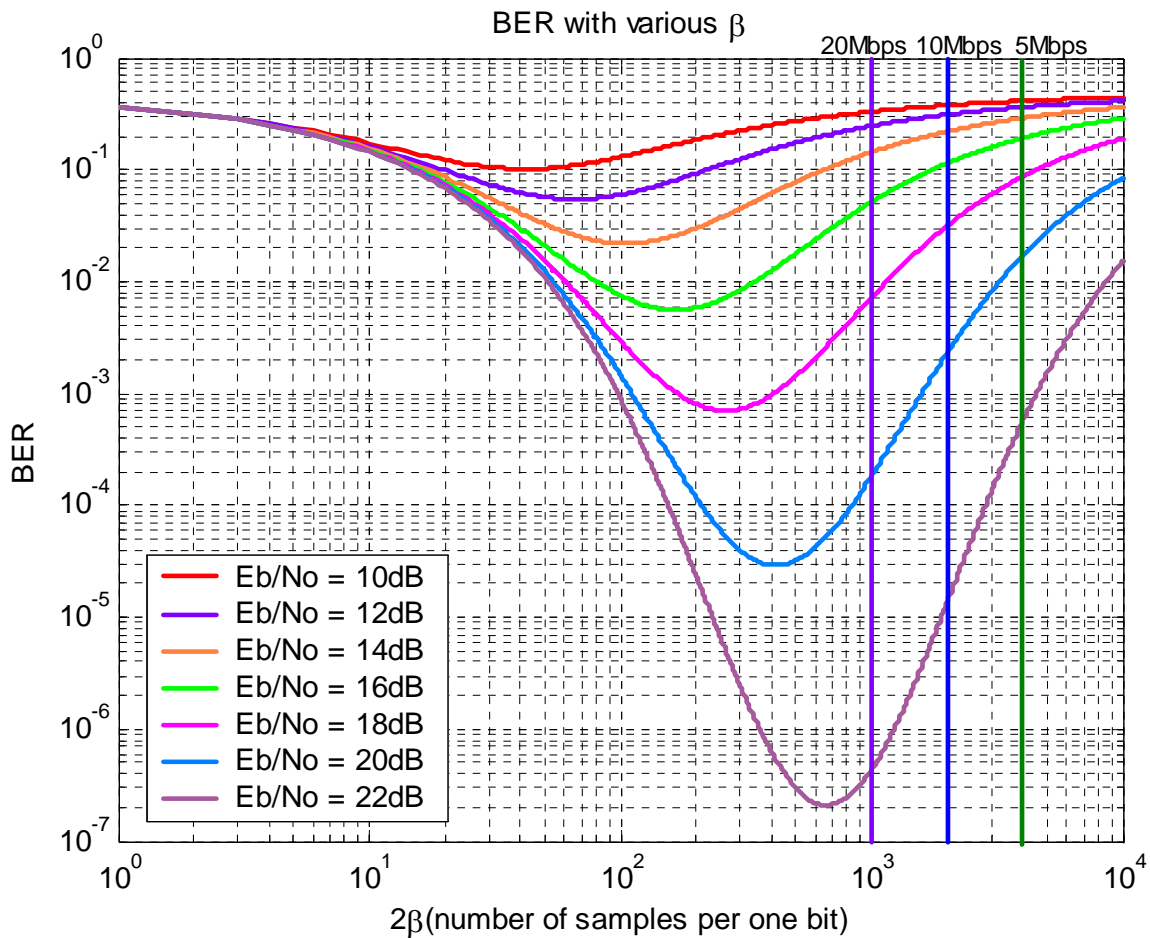

## 5.1. Channel models and payload data

**Refer to the selection criteria document**

- Industrial environment NLOS
- Indoor residential LOS
- Outdoor LOS
- Agricultural areas
- Body area networks

## 5.2. Size and Form Factor

### Values

#### ■ PHY-level (130 nm technology)

- RF part of transceiver => 0.3 mm<sup>2</sup>
- Analog part of transceiver PHY-level baseband => 0.2 mm<sup>2</sup>
- Digital part of transceiver PHY-level baseband => 0.3 mm<sup>2</sup>
- Common layout square for PHY-level => 1.0 mm<sup>2</sup>
- Antenna: 2.0 x 2.0 cm<sup>2</sup>

# 5.3. PHY-SAP Payload Bit Rate / Throughput

## Payload Bit Rate

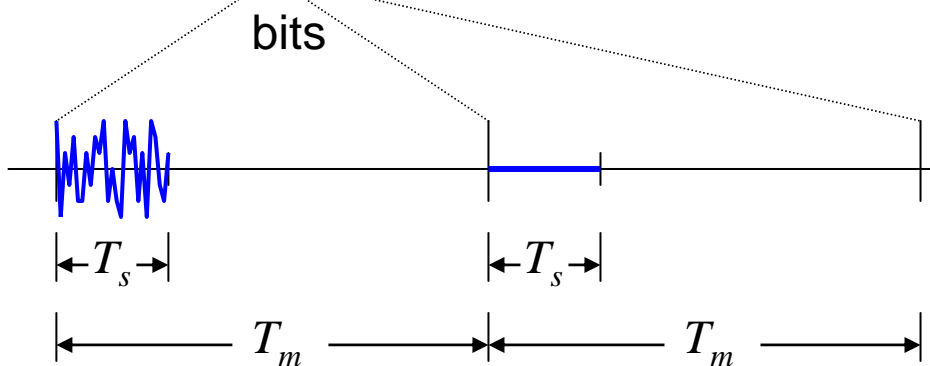
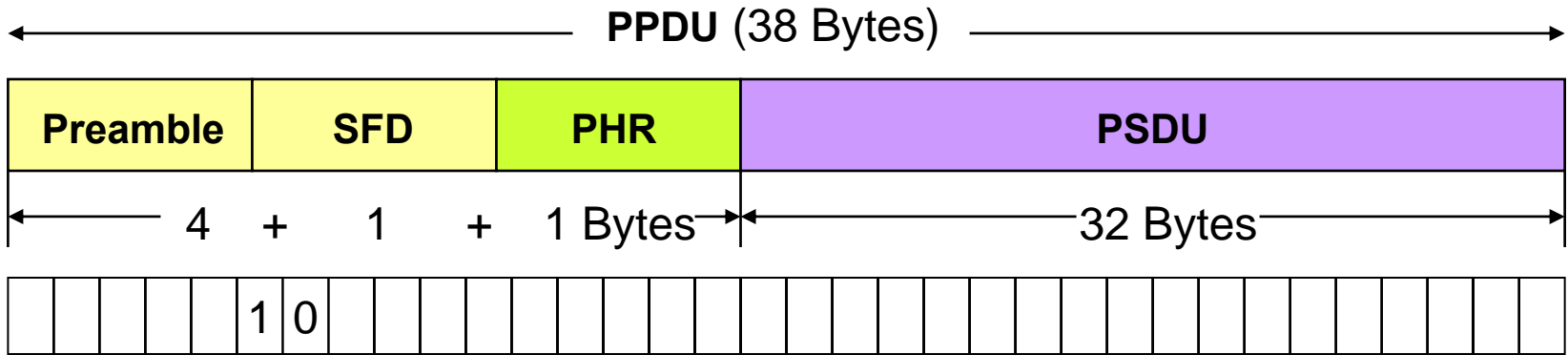

$T_s = 100 \text{ ns}$  : Pulse emission time  
 $T_m = 400 \text{ ns}$  : Pulse bin width or Bit period  
 $\therefore$  Duty cycle,  $D = 1/4$

$T_s = 100 \text{ ns}$  : Pulse emission time  
 $T_m = 600 \text{ ns}$  : Pulse bin width or Bit period  
 $\therefore$  Duty cycle,  $D = 1/6$

**Nominal PHY-SAP payload bit rate,  $X_0 = (1/400\text{ns}) \times (1000/1024) = 2.44\text{Mbps}$**

**Optional PHY-SAP payload bit rate,  $X_i = (1/600\text{ns}) \times (1000/1024) = 1.63\text{Mbps}$**

# 5.3. PHY-SAP Payload Bit Rate / Throughput

## Throughput

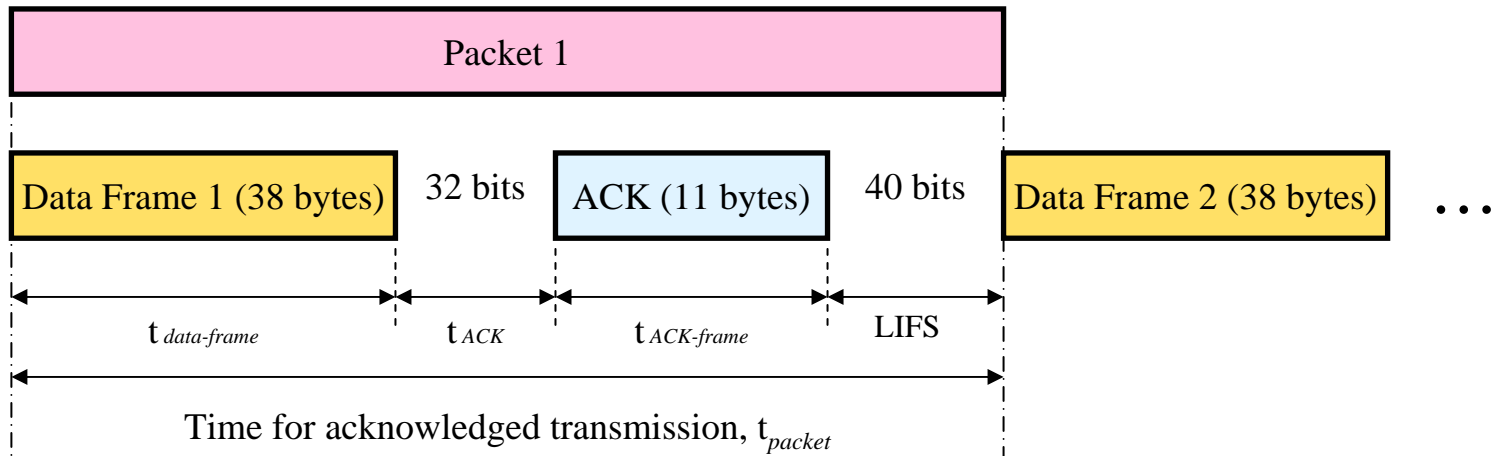

$$\begin{aligned}
 t_{packet} &= t_{data-frame} + t_{ACK} + t_{ACK-frame} + LIFS \\
 &= (38 \times 8 \times 400ns) + (32 \times 400ns) + (11 \times 8 \times 400ns) + (40 \times 400ns) \\
 &= 121.6\mu s + 12.8\mu s + 35.2\mu s + 16\mu s = 185.6\mu s
 \end{aligned}$$

$$\begin{aligned}
 t_{packet} &= t_{data-frame} + t_{ACK} + t_{ACK-frame} + LIFS \\
 &= (38 \times 8 \times 600ns) + (32 \times 600ns) + (11 \times 8 \times 600ns) + (40 \times 600ns) \\
 &= 182.4\mu s + 19.2\mu s + 52.8\mu s + 24\mu s = 278.4\mu s
 \end{aligned}$$

**Nominal Data Throughput,  $T_0 = (32 \times 8 / 185.6\mu s) \times (1000 / 1024) = 1.35Mbps$**

**Optional Data Throughput,  $T_i = (32 \times 8 / 278.4\mu s) \times (1000 / 1024) = 898kbps$**

## 5.4. Simultaneously Operating Piconets

### Three Methods to Achieve SOP

- **Frequency division multiplexing (FDM)**
  - Four independent frequency channels on 500 MHz guaranties simultaneously operating four piconets.
- **Code division multiplexing (CDM)**
  - Deployed a class of unipolar codes (0,1) having ZCD/LCD property maintain orthogonality among piconets.
  - Four set of codes can support four simultaneously operating piconets.
- **Frequency-code division multiplexing (FCDM)**
  - Two independent frequency channels with 1 GHz bandwidth and within each frequency channel, a set of codes is used
  - Ex: Only two codes are required to support four SOPs



# 5.4. Simultaneously Operating Piconets

## Combination of FDM and CDM (FCDM)

- 2 sub-bands and a set of codes for each sub-bands => at least 4 SOPs

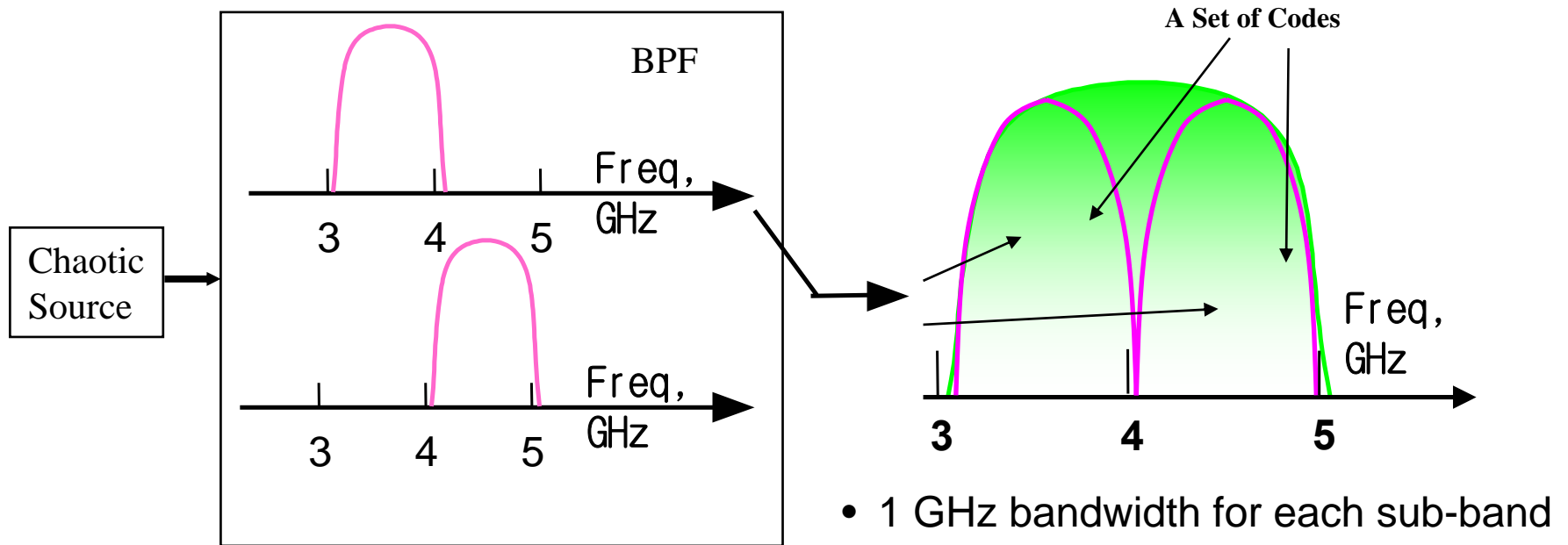

Subband	fc, GHz	fL, GHz	fR, GHz
1	3.6	3.1	4.1
2	4.6	4.1	5.1

## 5.4. Simultaneously Operating Piconets

### CDM Methods to Achieve SOP

#### ■ CDM for SOP can be achieved using Unipolar ZCD/LCD Code in chaotic-OOK modulation

- ZCD(Zero Correlation Duration): Local time duration with zero autocorrelation function sidelobe & zero cross-correlation function
- LCD(Low Correlation Duration): Local time duration with low zero autocorrelation function sidelobe & low cross-correlation function

\* Local time duration function as an Interference rejection interval for SOP

#### ■ Characteristics of combined schemes

- Simple circuit with noncoherent envelope detector
- Novel Inter/Intra Piconet Interference immunity for an efficient SOP

## 5.4. Simultaneously Operating Piconets

### Example of Unipolar ZCD Codes Type

#### ■ Type1 : Circular type sequence

- A code set is constructed by chip shift of a seed code
- An example of  $(8,4,0,0)$  with  $M=2$

code a=[1 0 1 0 1 0 1 0]

code b=[0 1 0 1 0 1 0 1]

#### ■ Type2 : Non-Circular type sequence

- An example of  $(5,2,0,0)$  with  $M=3$

code a=[1 0 0 1 0 0]

code b=[0 1 0 0 0 1]

code c=[0 0 1 0 1 0]

#### ■ Where $(N, W, A, C)$ is

- $N$  = sequence period,
- $W$  = number of nonzero elements,
- $A$  = ACF sidelobe in ZCD/LCD,
- $C$  = CCF value in ZCD/LCD
- $M$  = family size, Truncation of  $N/M = W$

# 5.4. Simultaneously Operating Piconets

## Transceiver Architecture of Chaotic-OOK Based ZCD/LCD-CDM

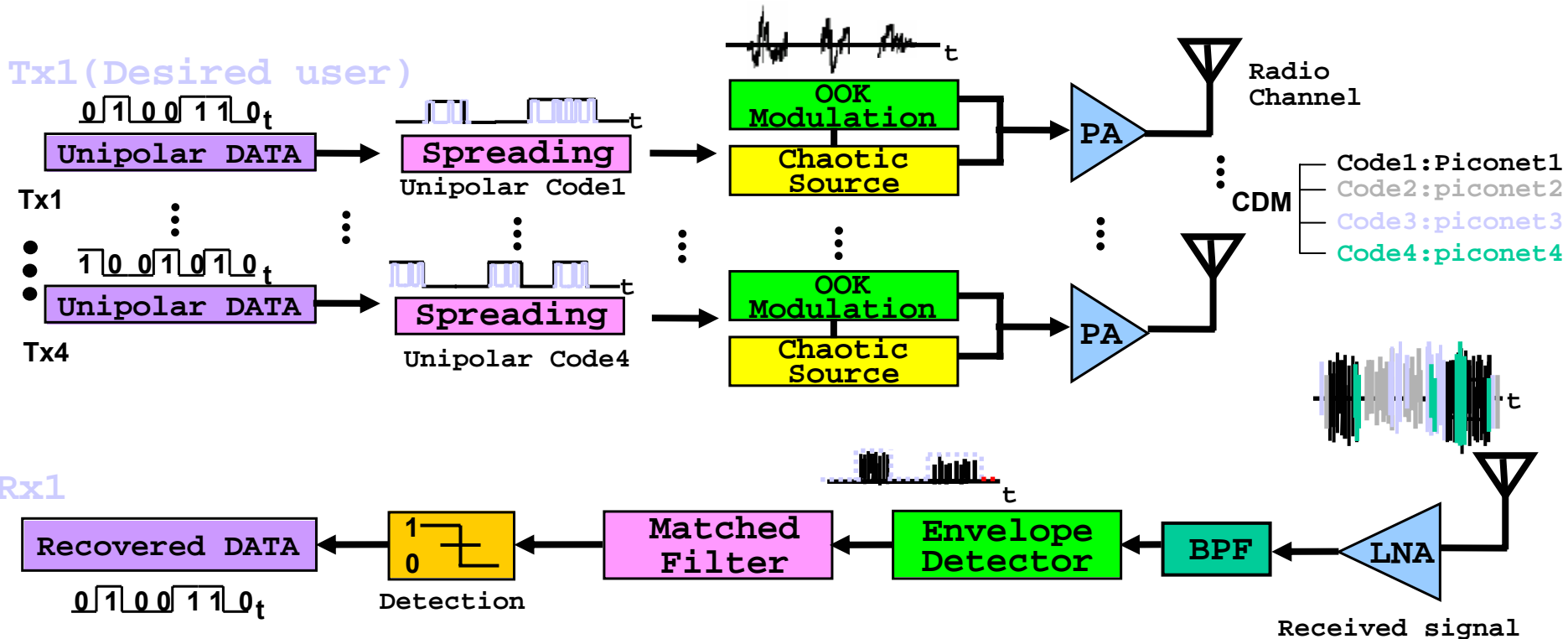

# 5.4. Simultaneously Operating Piconets

## Baseband Chaotic-OOK- ZCD-CDM

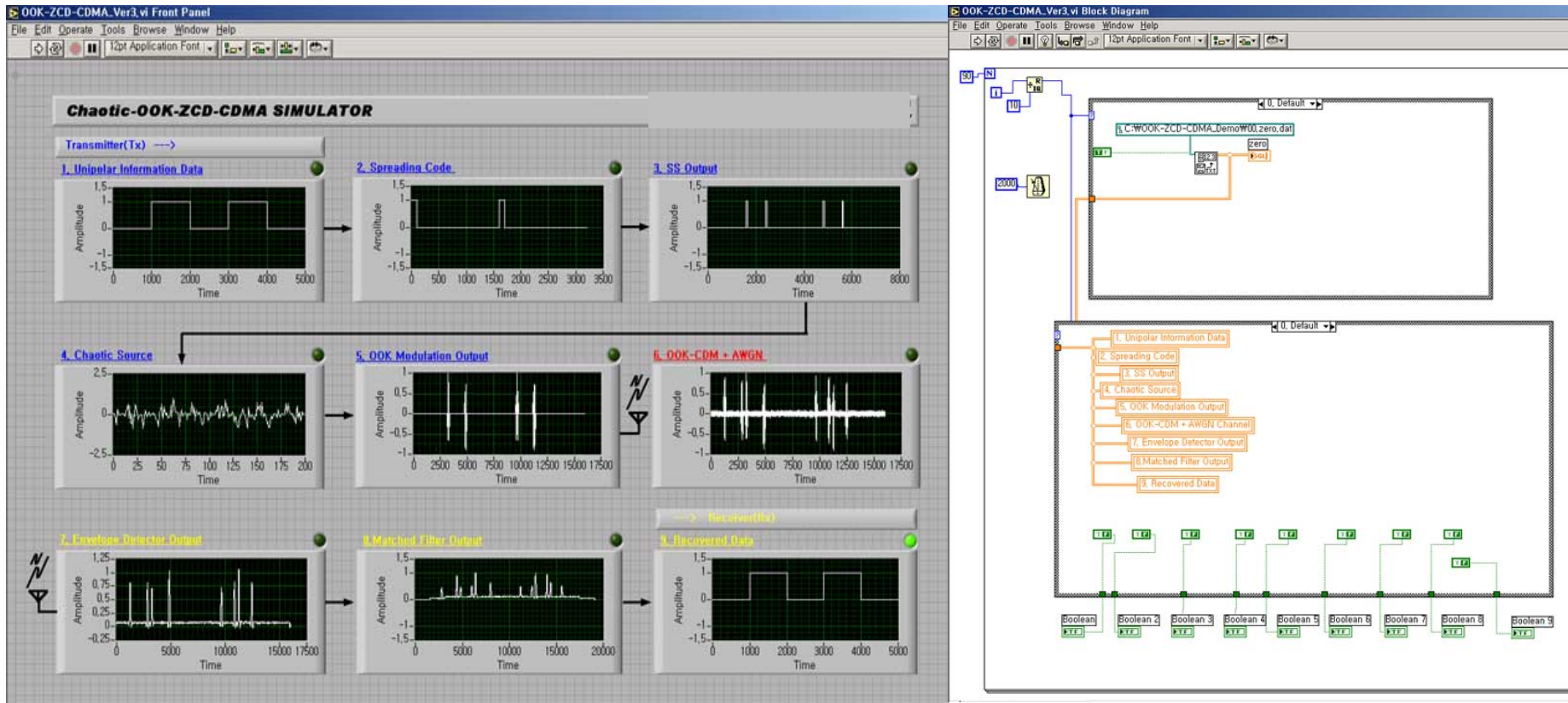

# 5.4. Simultaneously Operating Piconets

## Chaotic-OOK-ZCD-CDM

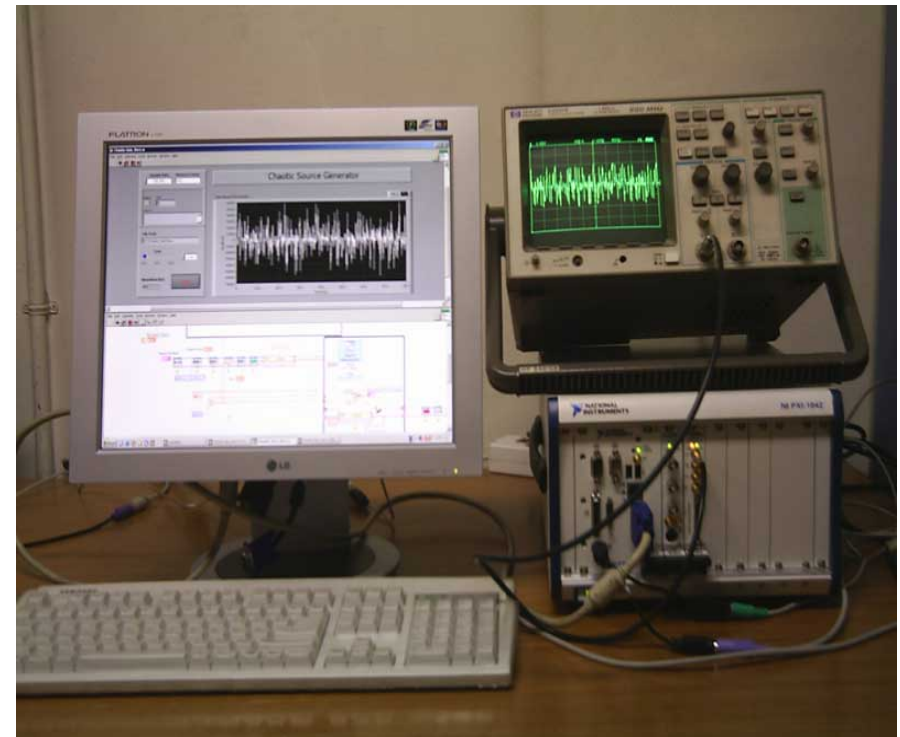
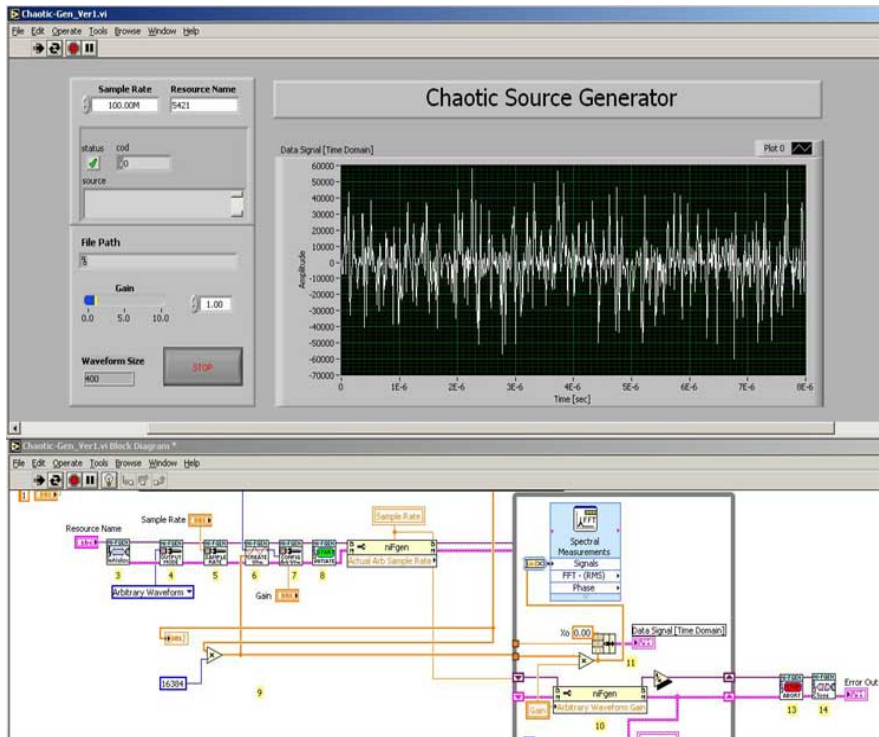

# 5.6. System Performance

## AWGN & Multipath

### ■ BER Vs. Eb/No

## AWGN & Multipath

### ■ PER Vs. Eb/No

2 GHz Bandwidth

2 GHz Bandwidth

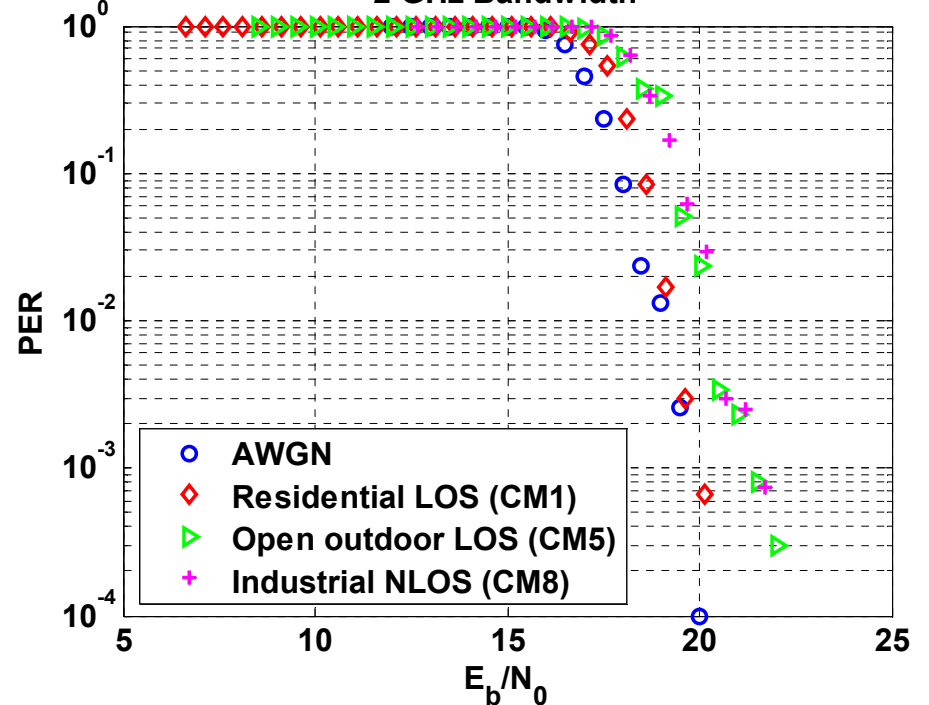
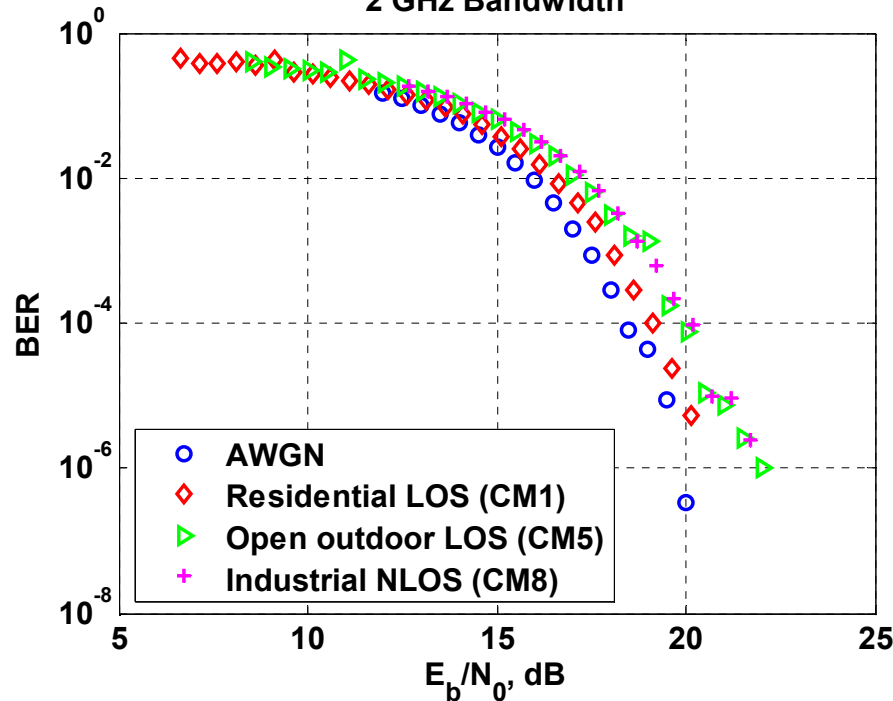

**Modulation:** OOK, **Bandwidth:** 2GHz, **Pulse width:**  $T_m=400\text{ns}$ ,  
**Pulse emission time:**  $T_s = 100\text{ns}$ , **PSDU length:** 32 bytes

## 5.6. System Performance

### Values: Bit Rate and Distance

<b>X<sub>o</sub></b> <b>(Mbps)</b>	<b>Channel</b>	<b>M+L1+L2 (free space), dB</b>	<b>PL, dB</b>	<b>PL<sub>0</sub>, dB</b>	<b>n</b>	<b>Distance, m</b>
<b>2.44</b>	<b>AWGN</b>	<b>76.27</b>	<b>76.27</b>	<b>44.43</b>	<b>2</b>	<b>39</b>
<b>1.63</b>	<b>AWGN</b>	<b>78.07</b>	<b>78.07</b>	<b>44.43</b>	<b>2</b>	<b>48</b>
<b>0.4075</b>	<b>AWGN</b>	<b>84.07</b>	<b>84.07</b>	<b>44.43</b>	<b>2</b>	<b>96</b>



# 5.7. Ranging

## Ranging Algorithm

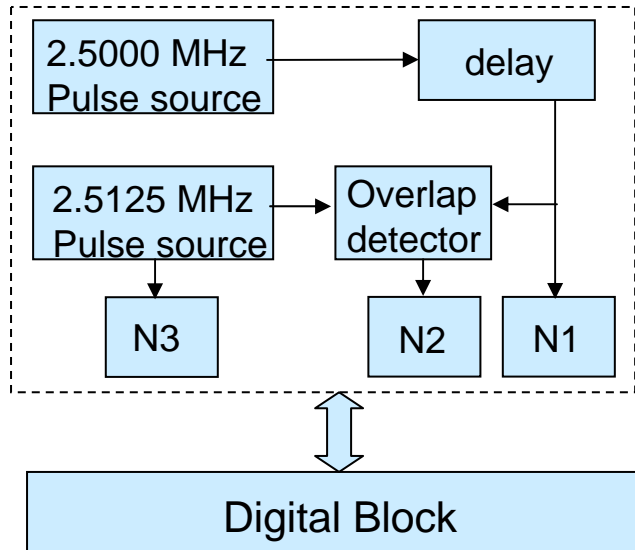

- Counter **N1** counts delayed pulses
- Counter **N2** counts overlaps between delayed pulses(2.5000 MHz) and reference pulses(2.5125 MHz)
- Counter **N3** counts reference pulses

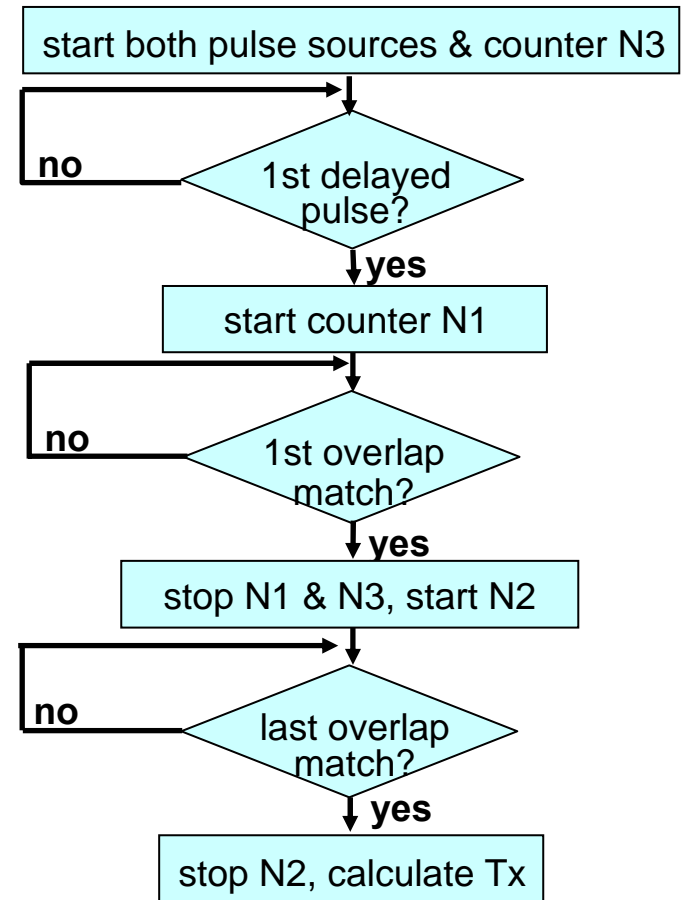

# 5.7. Ranging

## Operation of Counters

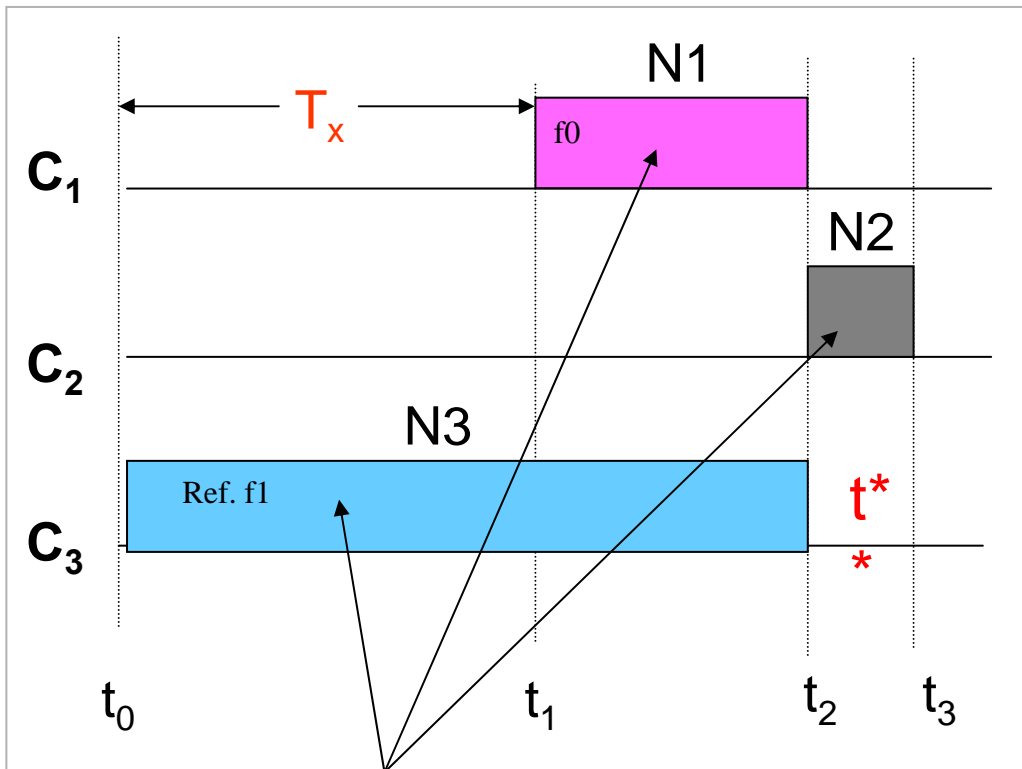

**N1, N2, N3** – pulse numbers

$$T_x = (N3 + 0.5 * N2) / f_1 - (N1 + 0.5 * N2) / f_0$$

**distance**

$$S = 0.5 * c * (T_x - \tau_0)$$

$\tau_0$  – retranslation time

Operation time of counters **C<sub>1</sub>, C<sub>2</sub>, C<sub>3</sub>**.

# 5.7. Ranging

## Overlapping of Delayed & Reference Pulses

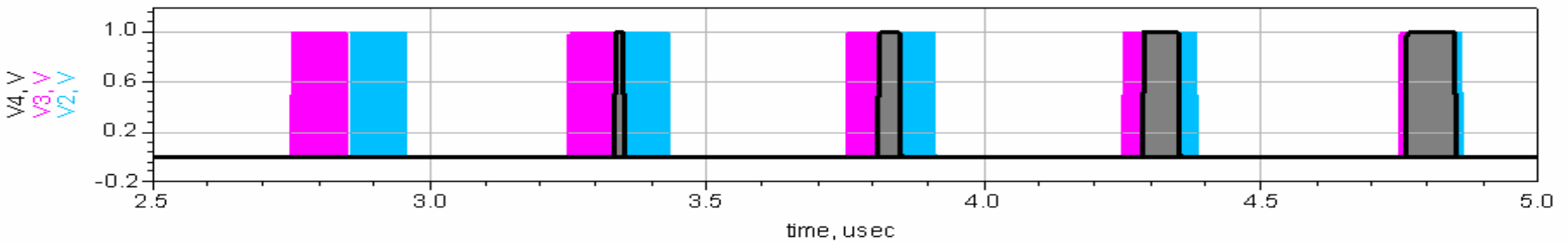
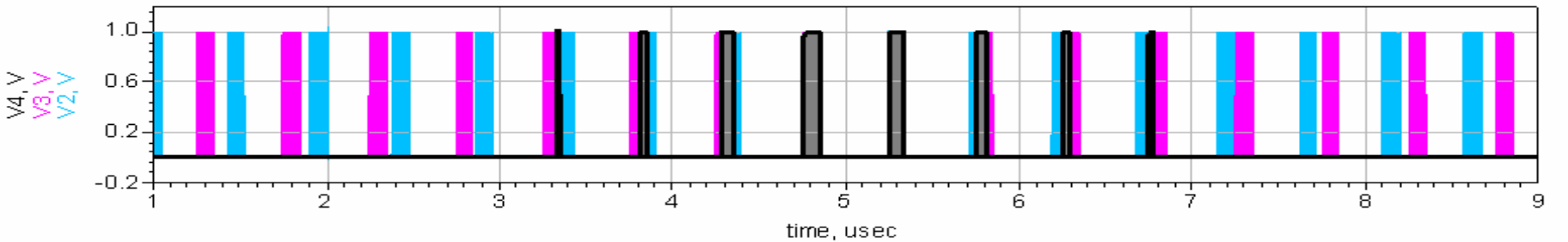

- Delayed pulse
- Reference pulse
- Pulse overlap

## 5.7. Ranging

### Values: Range

System supports ranges:

- Range from 0 to 30 m (typical)
- Range up to 100 m (max 10 kbps data rate)

# 5.8. Link Budget

Parameter	(mandatory) Value	(optional) Value
Peak payload bit rate ( $R_b$ )	$X_0=2440$ kbps	$X_i=1630$ kbps
Average Tx power ( $P_T$ )	-8.3 dBm	-8.3 dBm
Tx antenna gain ( $G_T$ )	0 dBi	0 dBi
$f'_c = \sqrt{f_{\min} f_{\max}}$ : geometric center frequency of waveform ( $f_{\min}$ and $f_{\max}$ are the -10 dB edges of the waveform spectrum)	3.976 GHz	3.976 GHz
Path loss at 1 meter ( $L_1 = 20 \log_{10}(4\pi f'_c / c)$ $c = 3 \times 10^8$ m/s)	44.43 dB	44.43 dB
Path loss at $d=30$ m ( $L_2 = 20 \log_{10}(d)$ )	29.54 dB	29.54 dB
Rx antenna gain ( $G_R$ )	0 dBi	0 dBi
Rx power ( $P_R = P_T + G_T + G_R - L_1 - L_2$ (dB))	-82.3 dBm	-82.3 dBm
Average noise power per bit ( $N = -174 + 10 * \log_{10}(R_b)$ )	-110.1 dBm	-111.9 dBm
Rx Noise Figure ( $N_F$ ) note <sup>1</sup>	7 dB	7 dB
Average noise power per bit ( $P_N = N + N_F$ )	-103.1 dBm	-104.9 dBm
Minimum $E_b/N_0$ ( $S$ )	15.5 dB	15.5 dB
Implementation Loss <sup>1</sup> ( $I$ )	3 dB	3 dB
Link Margin ( $M = P_R - P_N - S - I$ )	2.3 dB	4.1 dB
Proposed Min. Rx Sensitivity Level <sup>2</sup>	-86.1 dBm	-87.9 dBm

# 5.10. Power Management Modes

## Sleep and Wake-up Scheme

### Wake Up Structure

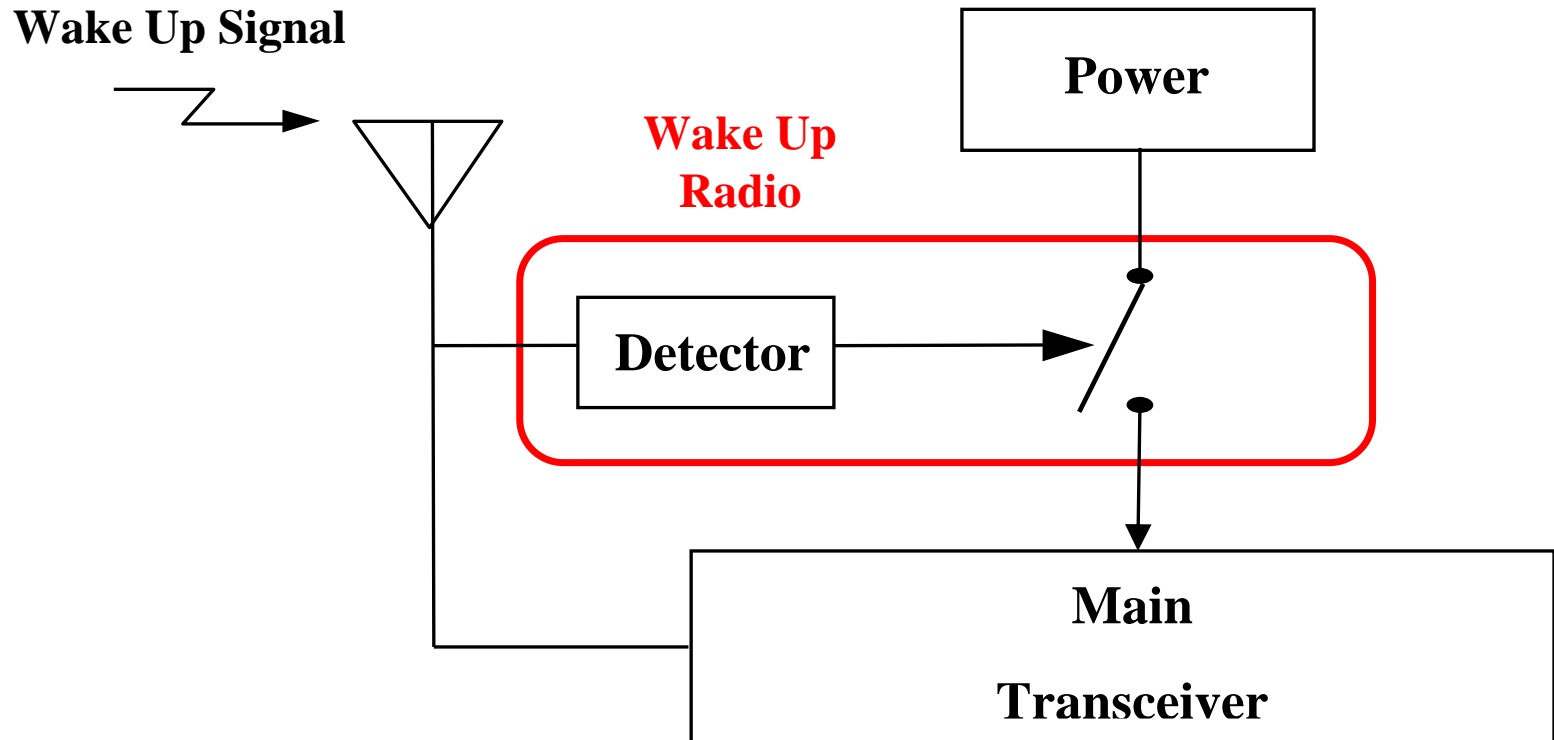

# 5.11. Power Consumption

## Power Calculation

Average power consumption  $P_{av}$

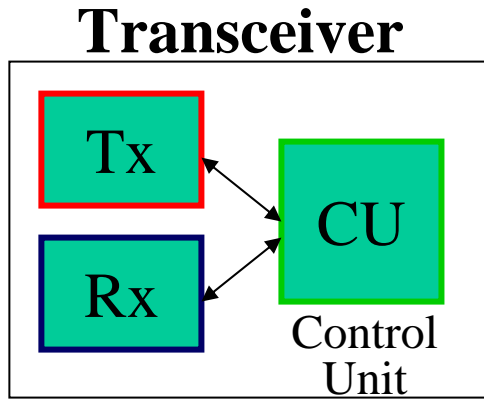

$$P_{av} = P_{Tx} + P_{Rx} + P_{CU}$$

$$P_{Tx} = P_e / \eta \quad P_{Rx} = P_e / \eta_{best}$$

$$P_e = P_{in} \cdot T_e = 1/2 \cdot D \cdot P_{in} \cdot T_{bit} \cdot R$$

Operation time  $T_{oper}$

$$T_{oper} = C_b \cdot U_b / P_{av}$$

$P_e$  is emitted power,

$\eta$  is efficiency,

$\eta_{best}$  is the best of all possible efficiencies,

$P_{in}$  is instantaneous emission power,

$T_e$  is time of emission for given transmission rate,

$T_{bit}$  is duration of one bit,

$R$  is transmission rate,

$C_b$  is battery capacity,

$U_b$  is battery voltage,

$D$  is duty cycle.

## 5.11. Power Consumption

### Duty Cycle and Power Consumption

Transmission Rate $R$ , kbps	Average Emitted Power $P_e$ , mW	Average Power Consumption $P_{av}$ ( $\eta = 5\%$ )	Lifetime of the AAA battery, years
1	$2 \cdot 10^{-4}$	15.5 $\mu$ W	8.3 100% duty cycle
10	$2 \cdot 10^{-3}$	87.5 $\mu$ W	15 10% duty cycle
1000	$2 \cdot 10^{-1}$	8 mW	16.4 0.1% duty cycle

$$P_{CU} = 7.5 \mu\text{W}; \quad P_{in} = 4 \text{ mW}; \quad \eta_{best} = 5\%; \quad U_b = 1.5 \text{ V}; \quad C_b = 750 \text{ mAh}; \quad D = 1/4$$

**Example:**  $R = 1 \text{ kbps}; T_{bit} = 400 \text{ ns}; \eta = 5\%$

$$P_e = 1/2 \cdot D \cdot P_{in} \cdot T_{bit} \cdot R = 0.2 \mu\text{W}$$

$$P_{av} = P_{Tx} + P_{Rx} + P_{CU} = P_e / \eta + P_e / \eta_{best} + P_{CU} = 15.5 \mu\text{W}$$



# Conclusion

- Chaotic communications meet the **low power, low cost & low complexity** requirements → best suited for 15.4a applications.
- Proposed DCC-OOK compliant with FCC UWB PSD regulation.
- Feasibility and scalability are guaranteed with **precision ranging** and **SOP** capabilities.
- The implemented test bed demonstrated the feasibility of DCC technology.

# **DCSK: Compatible Modulation Scheme for Direct Chaotic Communication**

# DCSK Modulation

## DCSK

### ■ Differential Chaos Shift Keying (DCSK)

- One of the modulation scheme as an alternative to OOK
- DCSK transmits a reference chaotic pulse and an information data pulse depending on whether information bit 1 (same ref. chaotic pulse) or 0 (inverted of the chaotic pulse) is being transmitted
- The information signal can be recovered in the receiver by a correlator with a constant decision threshold
- The Chaotic properties are maintained as same as OOK
- Data rate is as same as OOK
- SOP can be achieved by transmitting Chaotic pulses with different length

# DCSK Modulation

## Principle

$$s(t) = \begin{cases} x(t), & t_i \leq t < t_i + T/2 \\ +x(t - T/2), & t_i + T/2 \leq t < t_i + T \end{cases}$$

$$s(t) = \begin{cases} x(t), & t_i \leq t < t_i + T/2 \\ -x(t - T/2), & t_i + T/2 \leq t < t_i + T \end{cases}$$

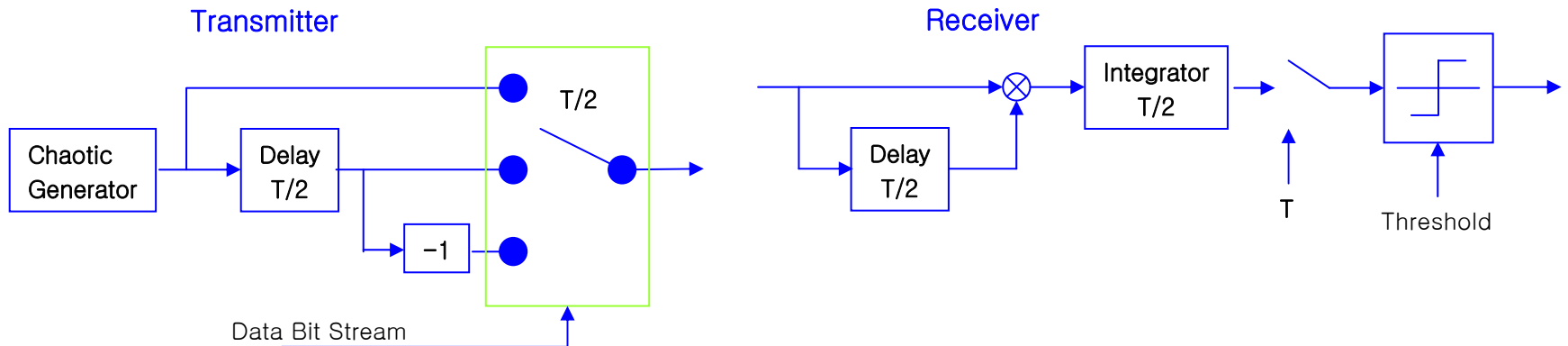
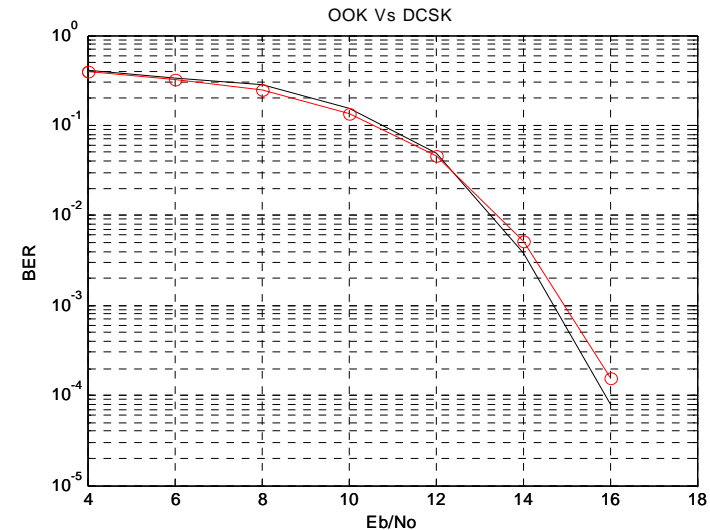

# DCSK Modulation

## System Simulation Results

### ■ AWGN & Multipath

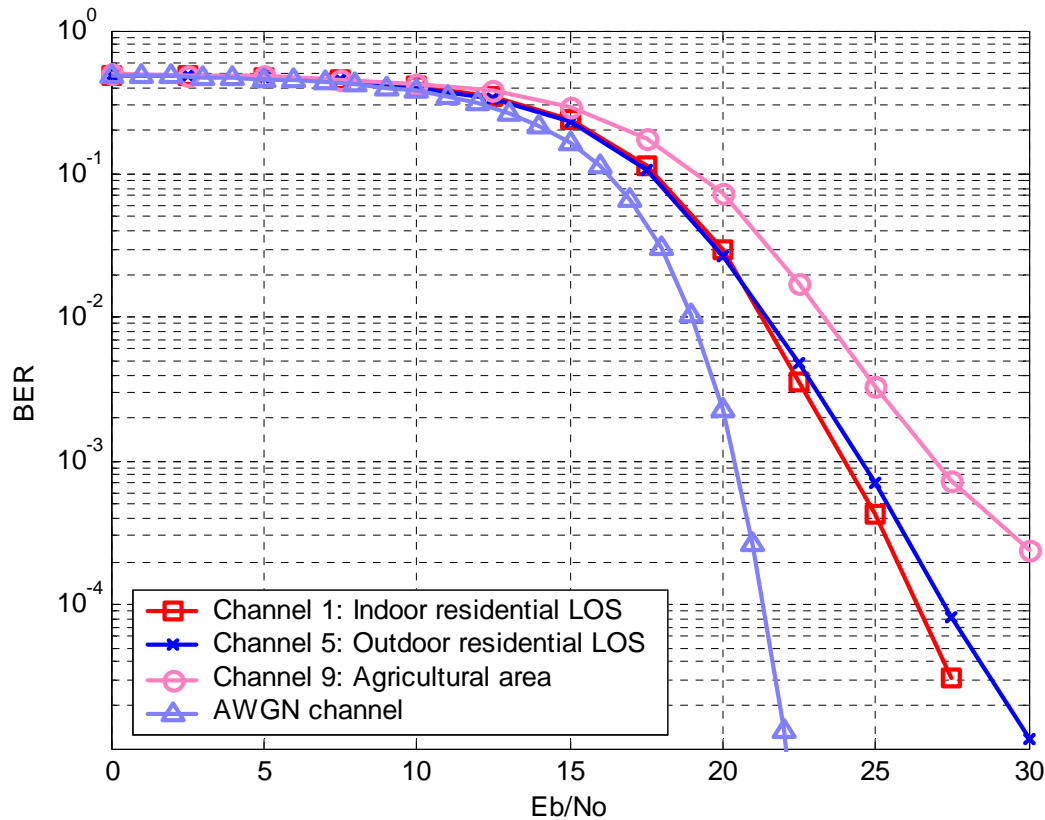

# DCSK Modulation

## SOP: LDMA

- In DCSK SOP can be done using Chaotic Length Division Multiple Access (LDMA)
- LDMA works based on the exploitation of different chaotic length assigned to each piconets.
- LDMA is based on the spectral and correlation property of chaotic signal

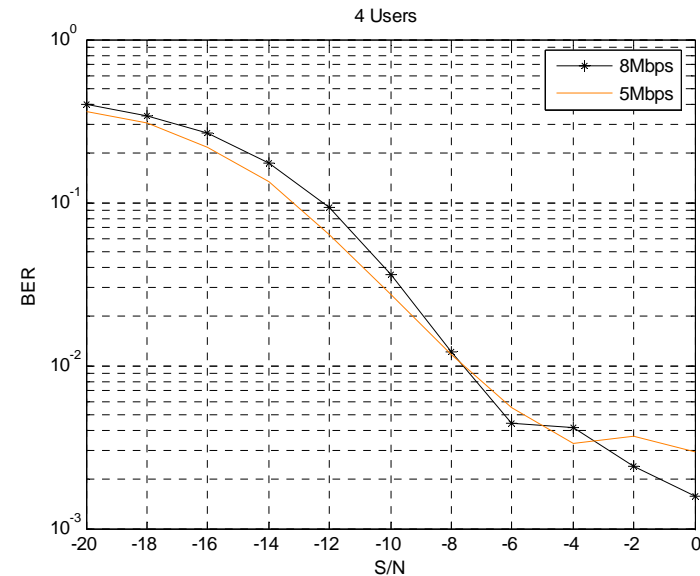
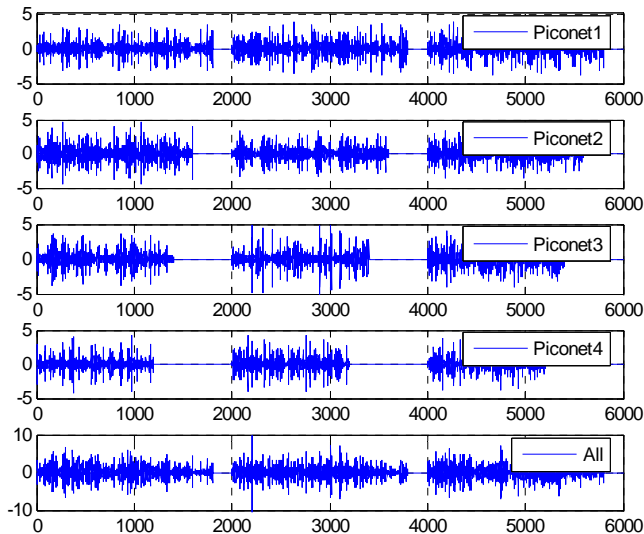
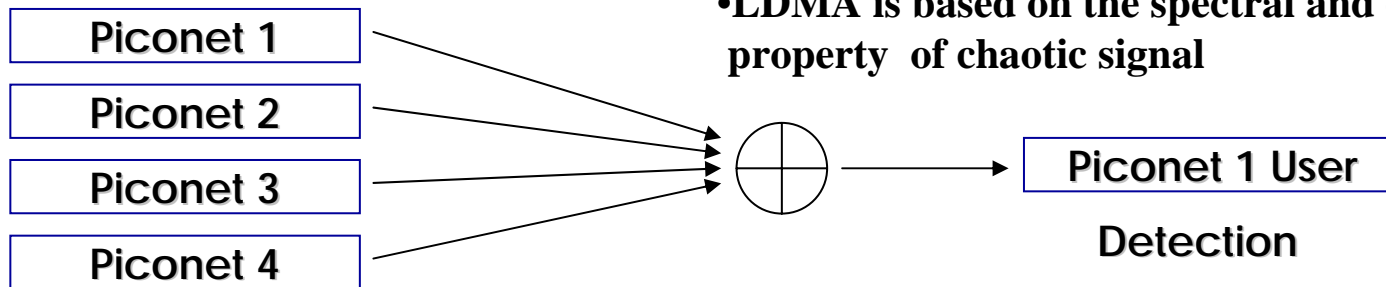

# DCSK Modulation

## Scalability

Scalability can be achieved using

- Chaotic gain
- Varying bit duration
- Duty cycle
- Repeated transmission of information bearing chip.

Bit = 1                      0                      1

200 nsec

5 Mbps

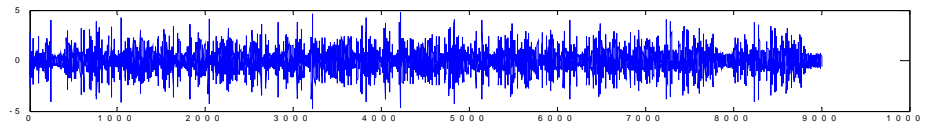

250 nsec

4 Mbps

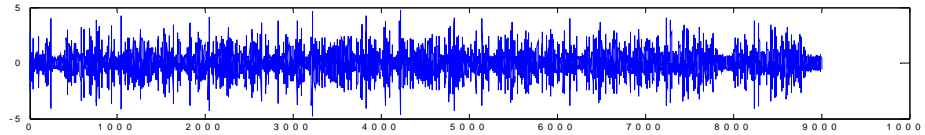

500 nsec

1 Mbps

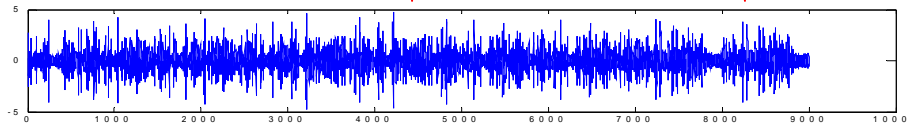

## Chaotic Gain in DCSK

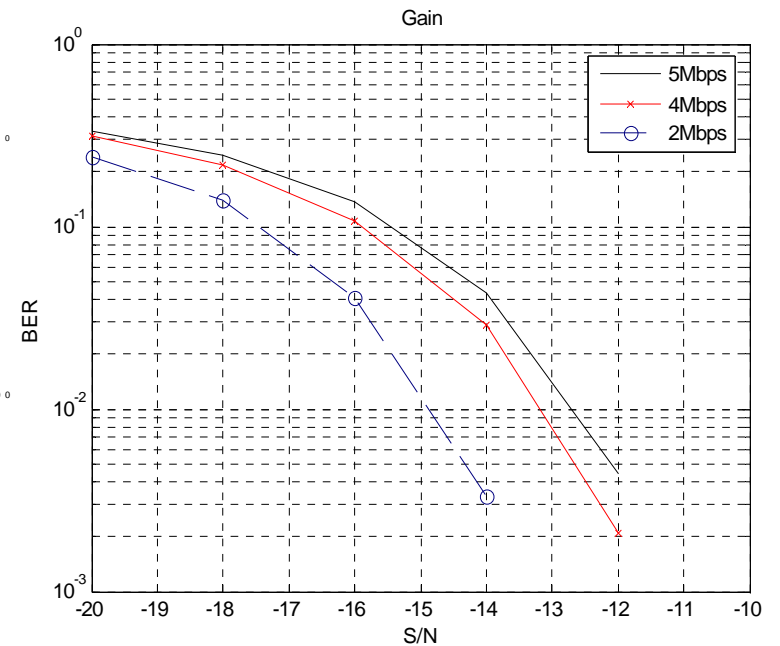

# MCS-DCSK Modulation

## Combination of MCSK TH-IR with DCSK

### ■ MCS-DCSK

- M-ary code shift keying (MCSK)/binary pulse position modulation (BPPM) for time hopping (TH) impulse radios (IR's) can be used in Chaotic Communications such as DCSK in order to increase the system performance



# MCS-DCSK Modulation

## DCSK TX Signal

DCSK transmitting  $d=[d_1 \ d_2]$ ,  $d_i \in (-1,1)$

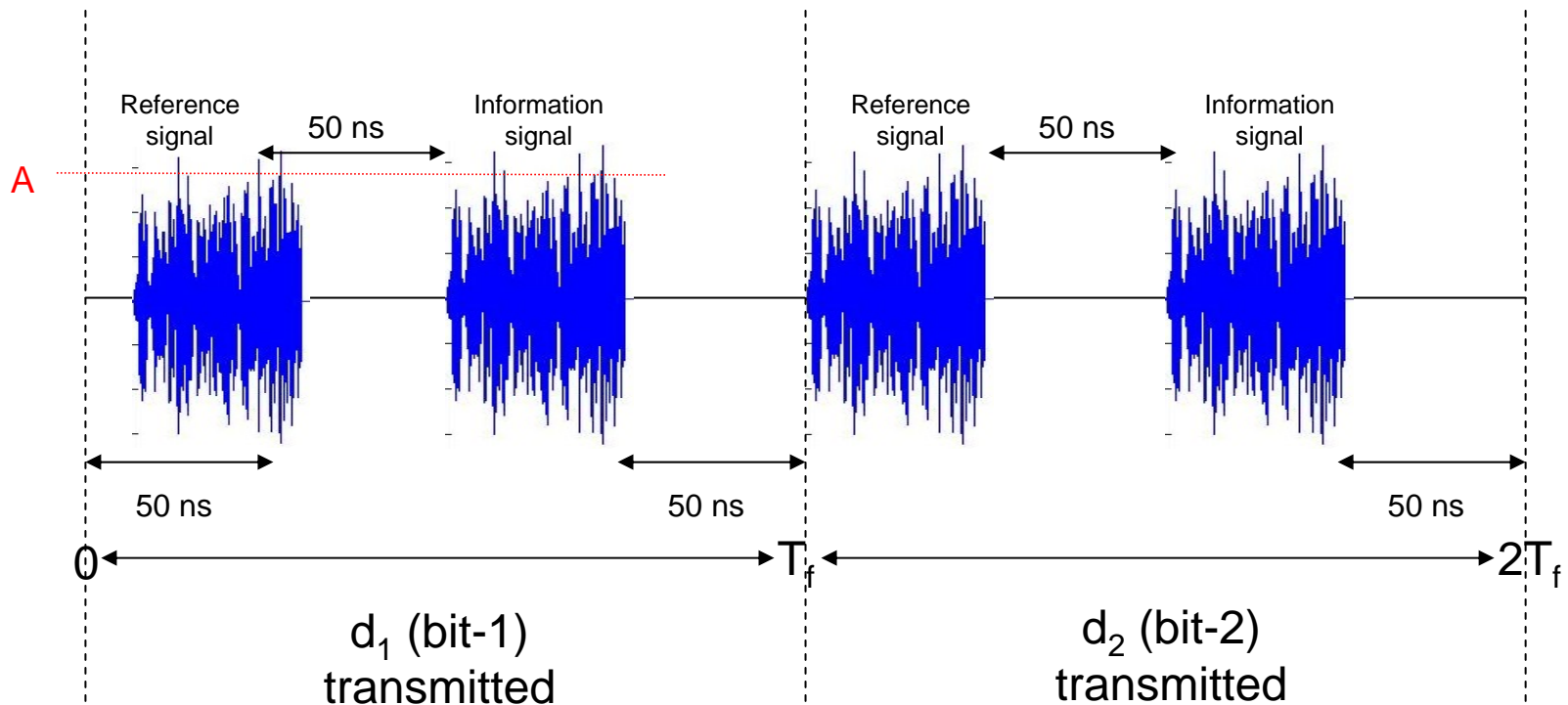

where *info. signal* =  $sign(d_i) \times ref. signal$



# MCS-DCSK Modulation

## DCSK TX and RX Signal

DCSK: Transmitted and received signals (CM1, no AWGN)

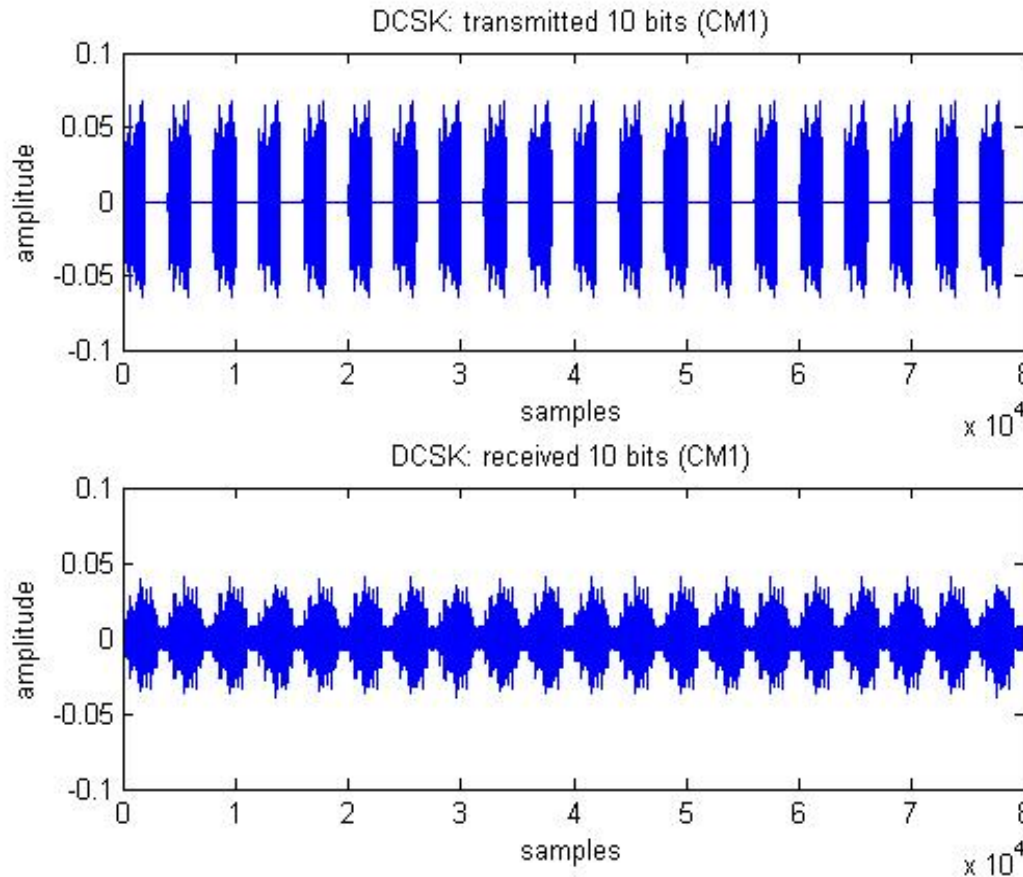

# MCS-DCSK Modulation

## MCS-DCSK TX Signal

MCS-DCSK transmitting  $d=[d_1 \ d_2]$ ,  $d_i \in (-1,1)$

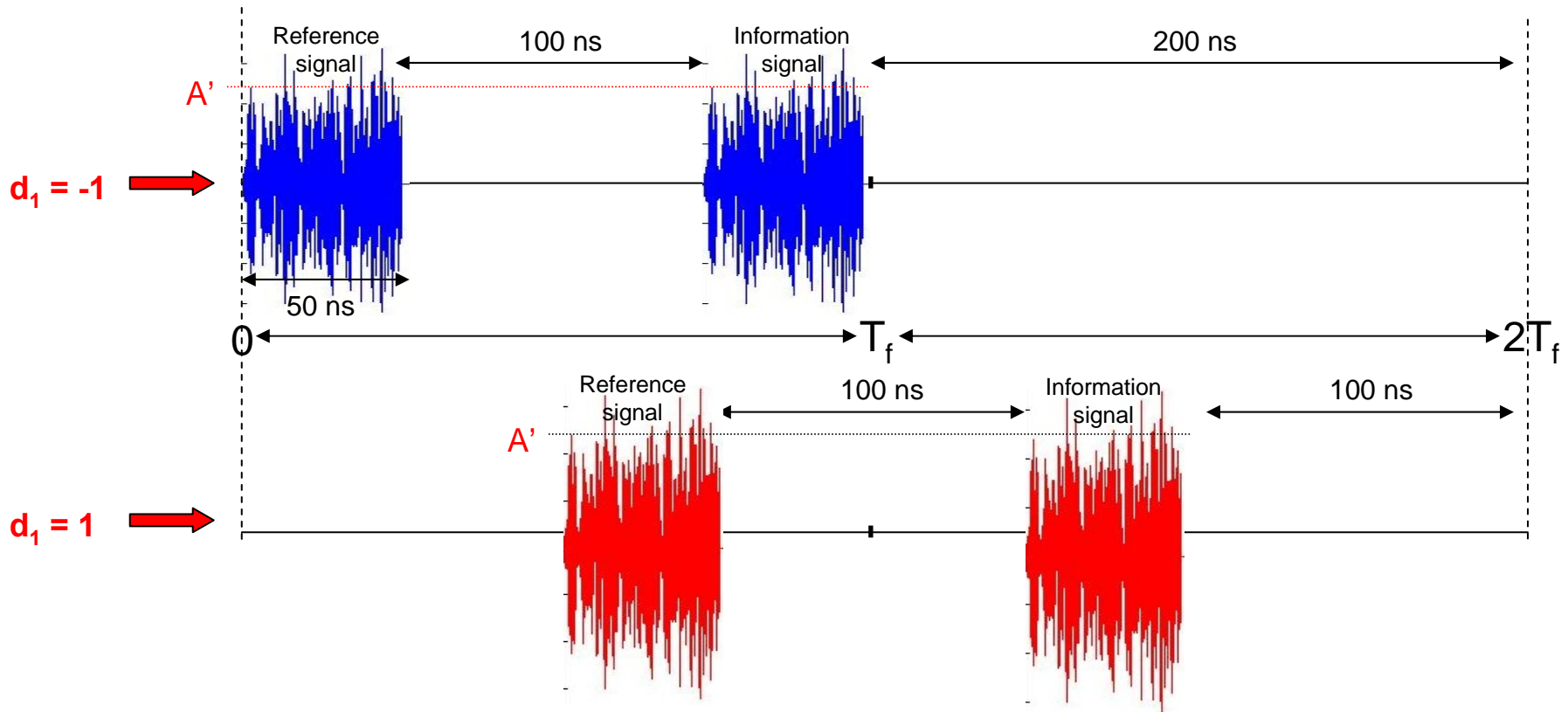

where *info. signal* =  $\text{sign}(d_2) \times \text{ref. signal}$

# MCS-DCSK Modulation

## MCS-DCSK RX Signal

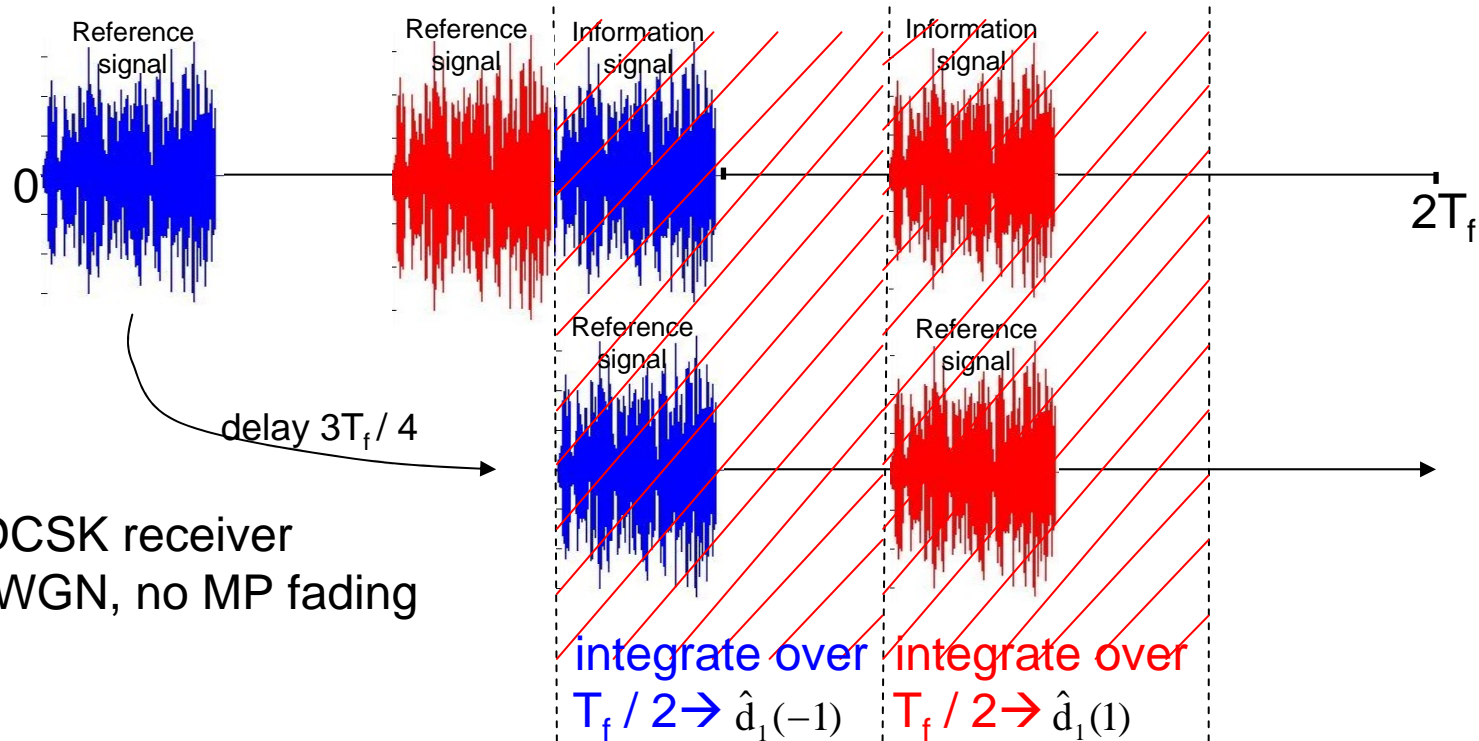

MCS-DCSK receiver  
 – no AWGN, no MP fading

**Decision** {  
 Step 1:  $|\hat{d}_1(-1)| > |\hat{d}_1(1)| \longrightarrow d_1 = -1$ ;  $|\hat{d}_1(-1)| < |\hat{d}_1(1)| \longrightarrow d_1 = 1$   
 Step 2: if  $d_1 = -1 \longrightarrow d_2 = \text{sign}(\hat{d}_1(-1))$ ; if  $d_1 = 1 \longrightarrow d_2 = \text{sign}(\hat{d}_1(1))$

# MCS-DCSK Modulation

## MCS-DCSK TX and RX Signal

MCS-DCSK: Transmitted and received signals (CM1, no AWGN)

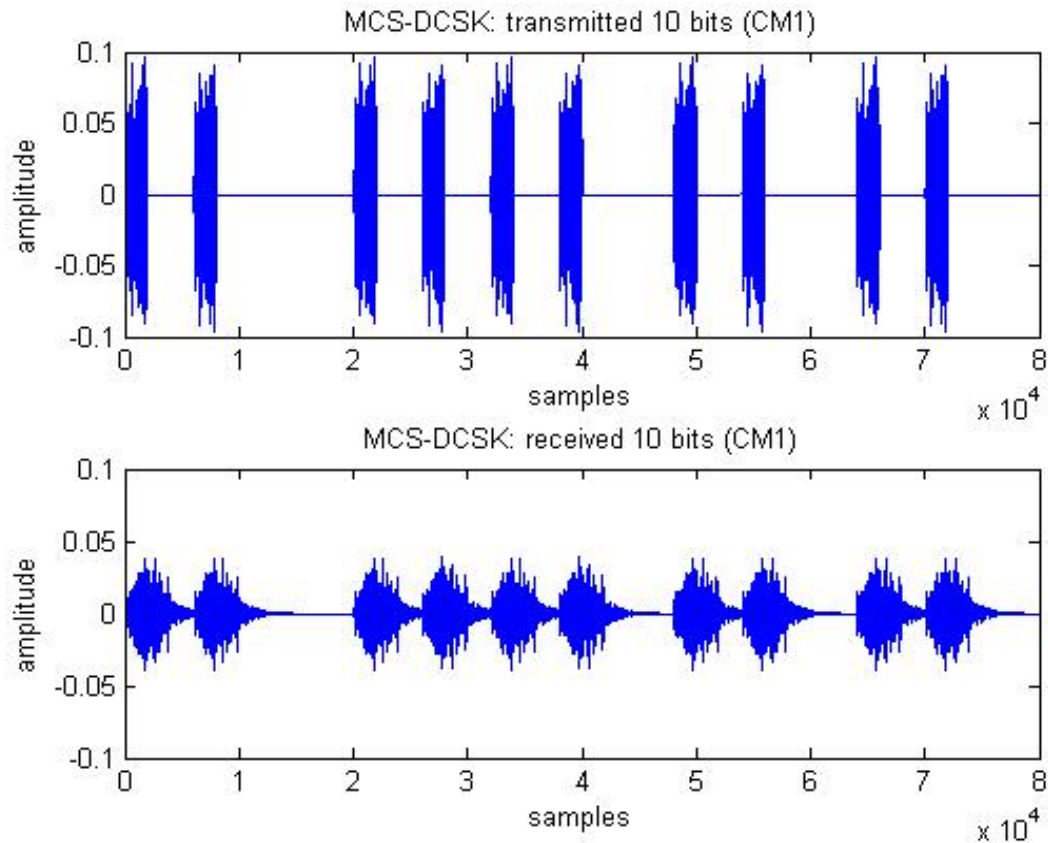

# MCS-DCSK Modulation

## MCS-DCSK Simulation Results

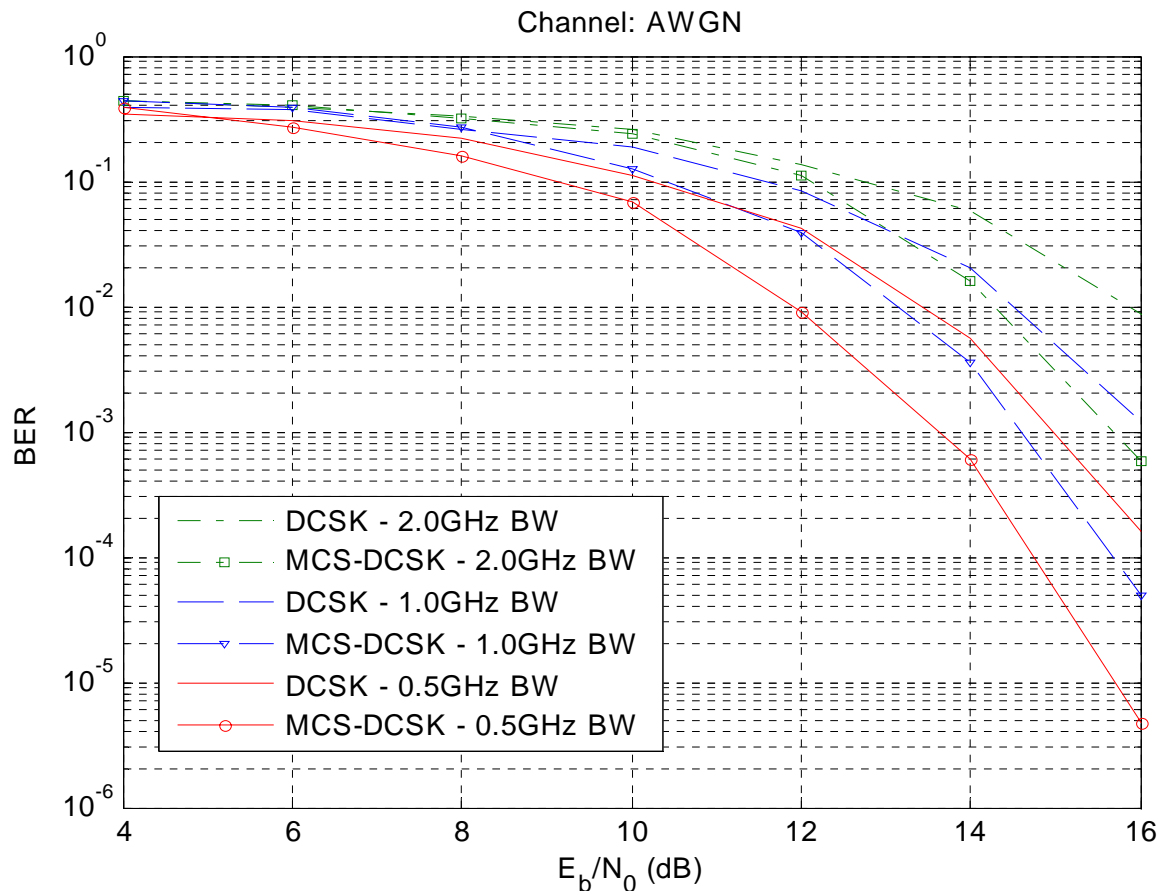

# MCS-DCSK Modulation

## MCS-DCSK Simulation Results

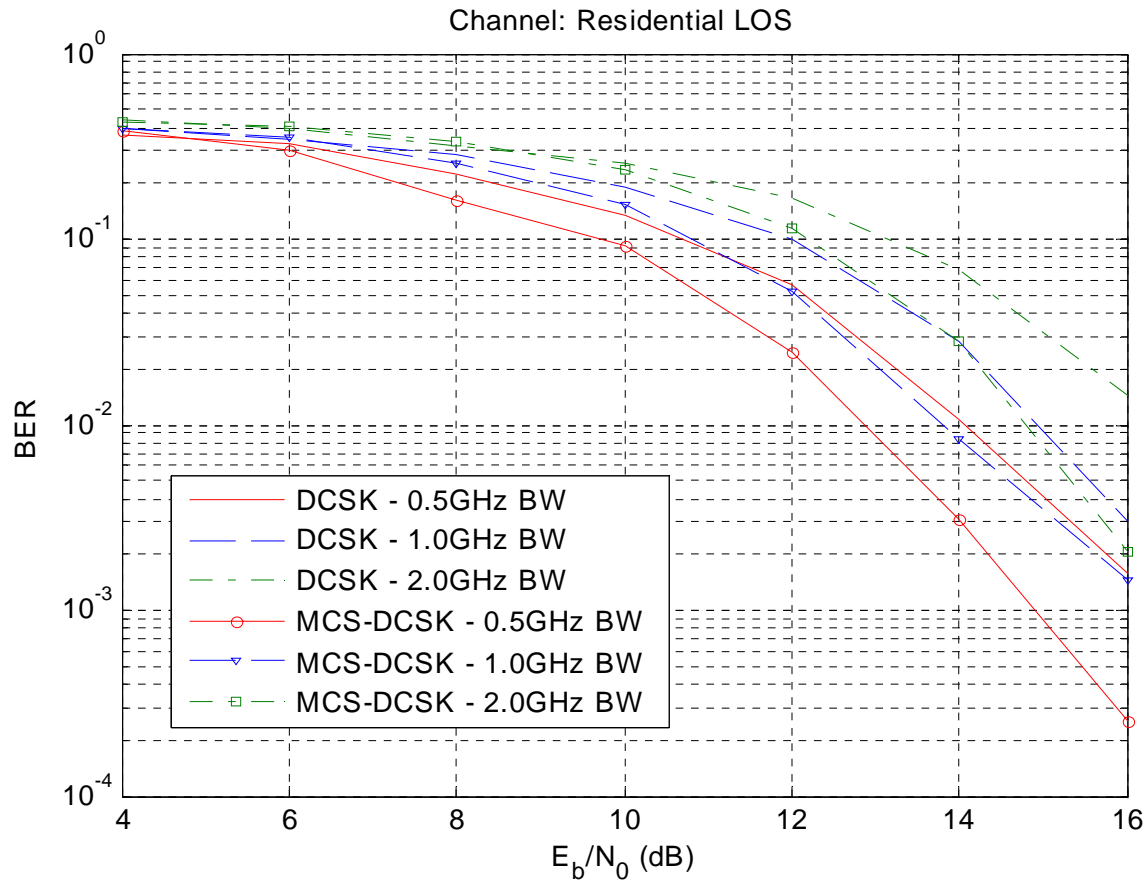



# DCSK Modulation

## Complexity, Cost & Technical Feasibility

- Complexity and cost will be slightly higher compare to the OOK chaotic system proposed

## Conclusion

- Chaotic communication based on DCSK modulation is an alternative solution for TG4a.
- Most hardware from OOK is retained.
- SOP and ranging can be solved effectively using DCSK.

# **MC-PPM : Compatible Modulation Scheme for Direct Chaotic Communication**

# MC-PPM Modulation

## MC-PPM

- **Multi-coded Pulse Position Modulation (MC-PPM)**
  - Power efficient scheme
  - Inherent coding gain due to orthogonal multi-codes
  - Support wide pulse shaping in same data rate condition
  - Constant decision threshold in the receiver
  - OOK is one special mode of MC-PPM

# MC-PPM Modulation

## Principle

### ■ Principle operation (L=3, Ns=4)

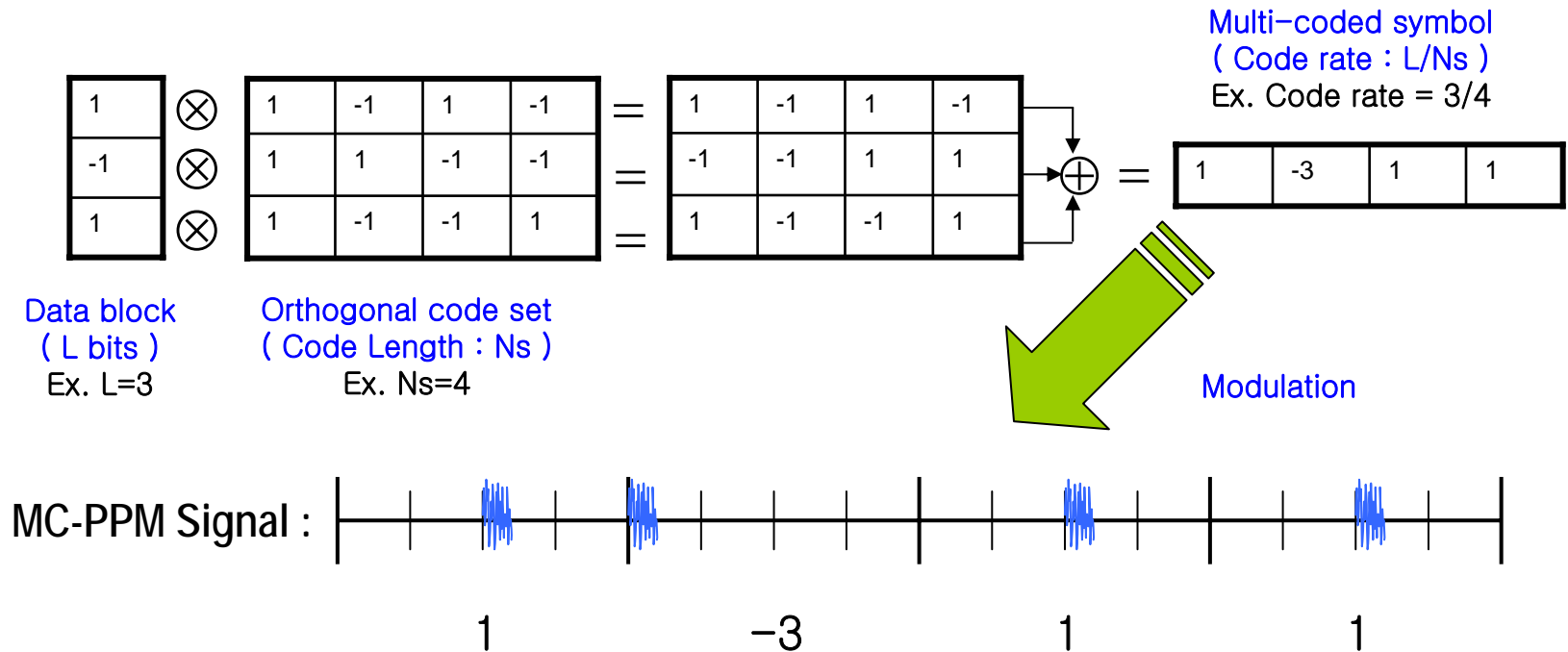

# MC-PPM Modulation

## Data Frame Structure

- 1 data block (L data) interval of PSDU :

$$T_d = N_r(T_s + T_g), \quad T_s = N_s T_c, \quad T_c = (L + 1)T_m$$

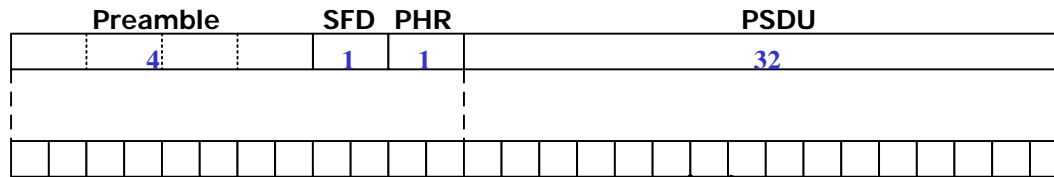

- $L$  : # of bits per data block
- $N_s$  : Orthogonal code length
- $N_r$  : # of repetitions
- $T_m$  : Pulse bin width (duration)
- $T_c$  : Multi-coded chip duration
- $T_s$  : Multi-coded symbol duration
- $T_g$  : Guard time for processing delay
- $T_d$  : Total transmit time duration of a data block

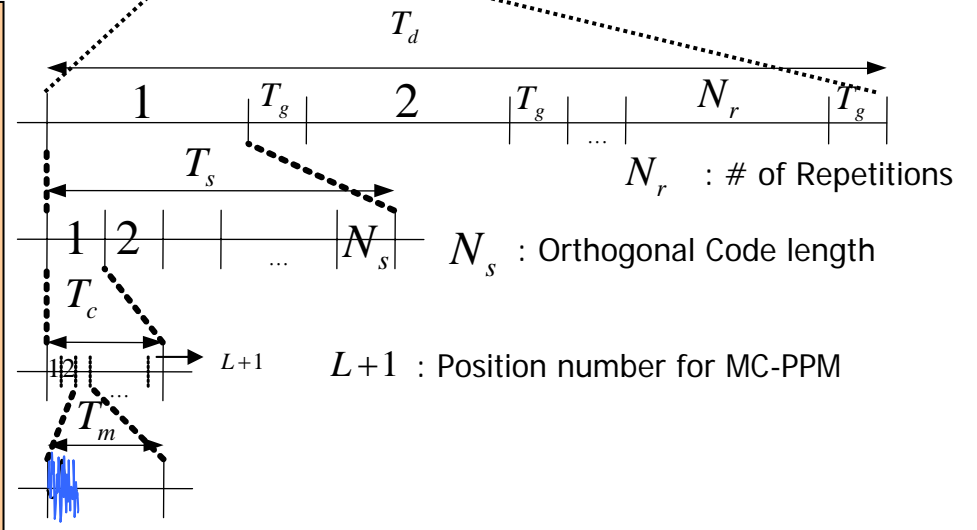

# MC-PPM Modulation

## Transceiver Architecture

- Transmitter

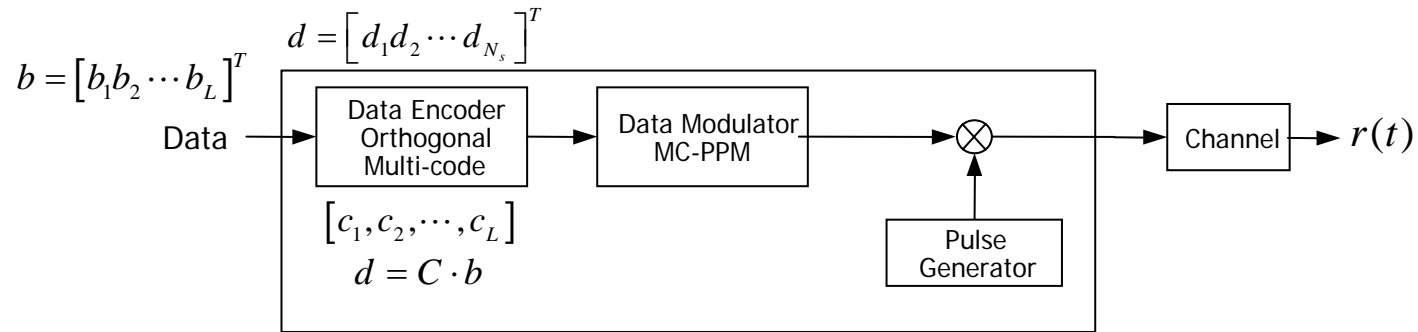

- Receiver

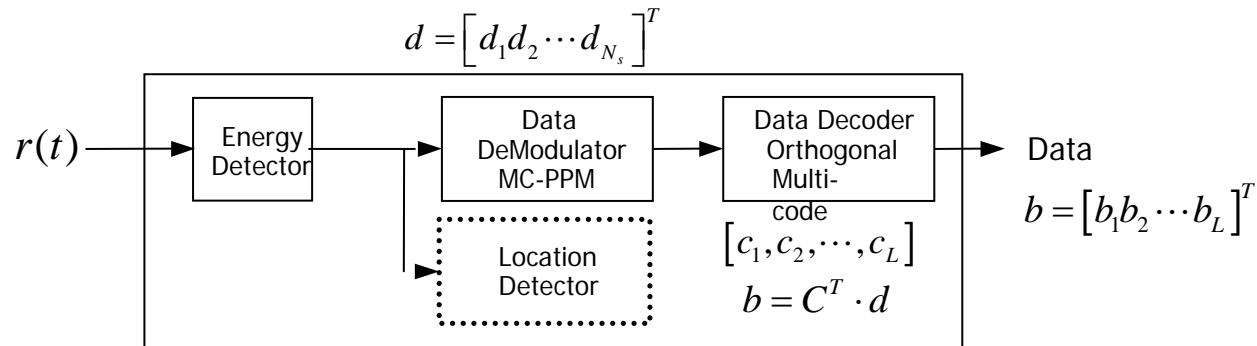

# MC-PPM Modulation

## PHY-SAP Data Rates

- Flexible data rates can be supported according to several design parameter ( $T_m$ ,  $L$ ,  $N_s$ ,  $N_r$ ,  $T_g$ )

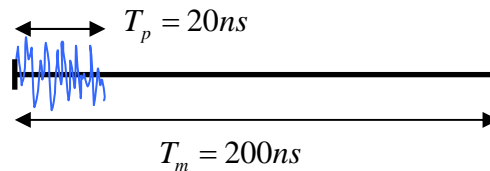

$T_p$	$T_m$	$L$	$N_s$	$N_r$	$T_g$	Data Rate
20ns	200ns	1	16	128	0ns	1.190 kbps
20ns	200ns	3	16	1	0ns	228 kbps
20ns	200ns	3	8	1	0ns	457 kbps
20ns	200ns	1	<b>1</b>	1	0ns	<b>2.44 Mbps</b>

# MC-PPM Modulation

## Data Throughput

### Data Throughput

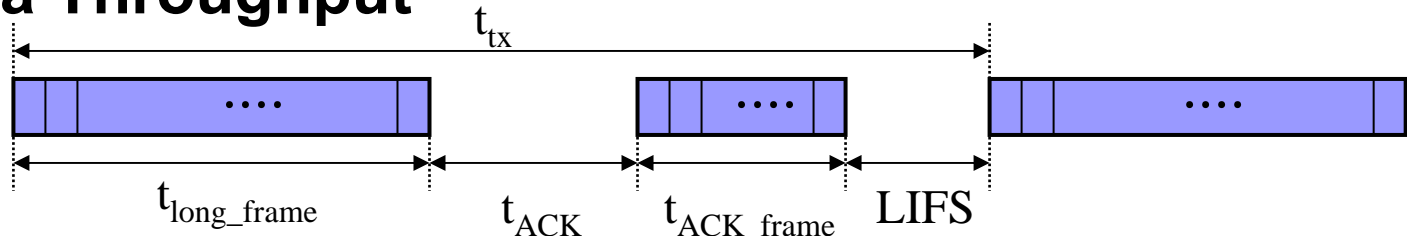

### Transmission time (ttx) & Data throughput (Rth)

- For L=3, Ns=8, Nr=1, Tg=0ns (**457kbps**)
  - ttx = tlong\_frame + tACK + tACK\_frame + LIFS  
= 614.4 u + 25.6 u + 187.7 u + 85.3 u = 913 u
  - Rth = 32×8 / 913u ≈ **280.3 kbps**  
( Nominal throughput based on 32 bytes payload )
- For L=3, Ns=16, Nr=1, Tg=0ns (**228kbps**)
  - ttx = tlong\_frame + tACK + tACK\_frame + LIFS  
= 1228.8 u + 51.2 u + 375.5 u + 170.7 u = 1826.2 u
  - Rth = 32×8 / 1826.2 u ≈ **140.2 kbps**  
( Nominal throughput based on 32 bytes payload )



# MC-PPM Modulation

## Signal Acquisition

- Energy detection based acquisition
- Acquisition should be performed in order to make synchronization and demodulate data
- Synchronization : Non-coherent

# MC-PPM Modulation

## Performance

### ■ MC-PPM Performance : AWGN

- BER & PER

– L=3, N<sub>s</sub>=8, N<sub>r</sub>=1 (457 kbps PHY-SAP data rate)

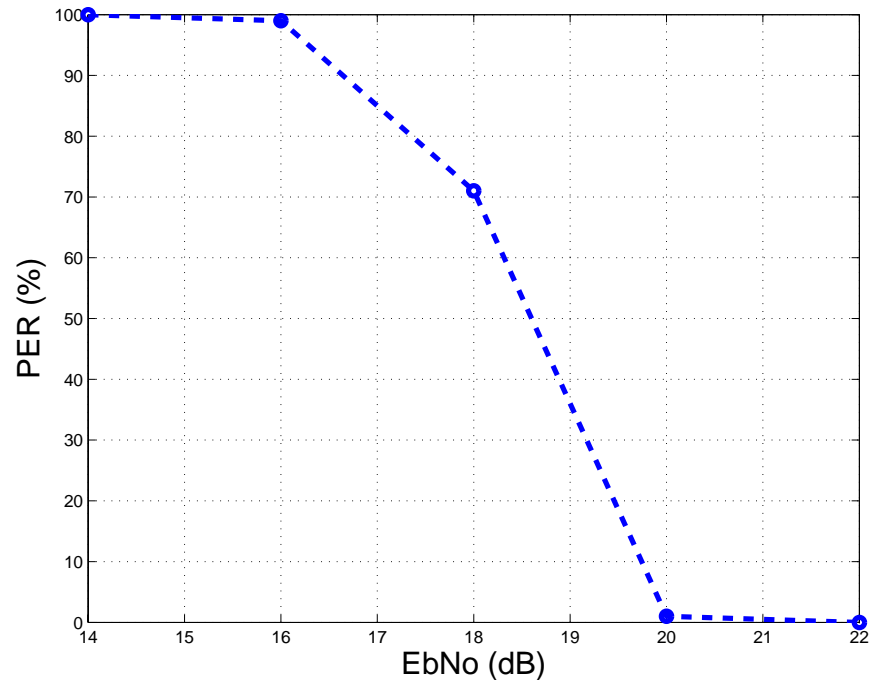
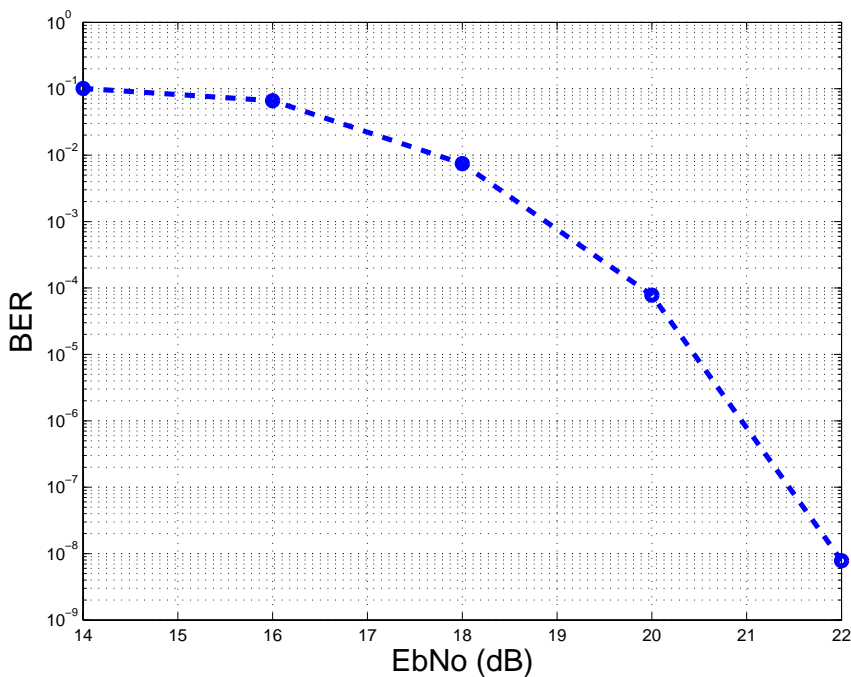

# MC-PPM Modulation

## Performance

### ■ MC-PPM Performance : 4a Channel Models

- BER & PER
  - $L=3, N_s=8, N_r=1$

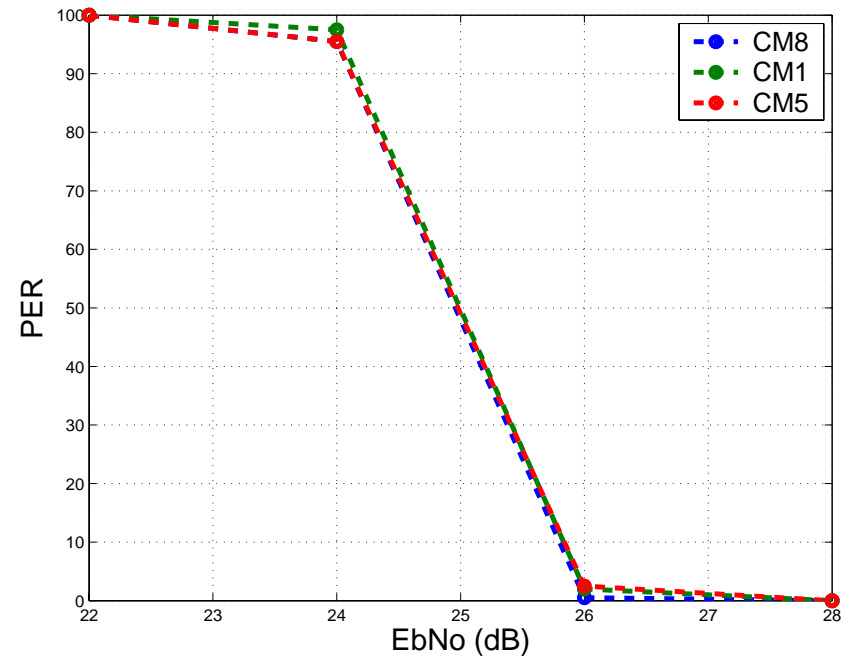
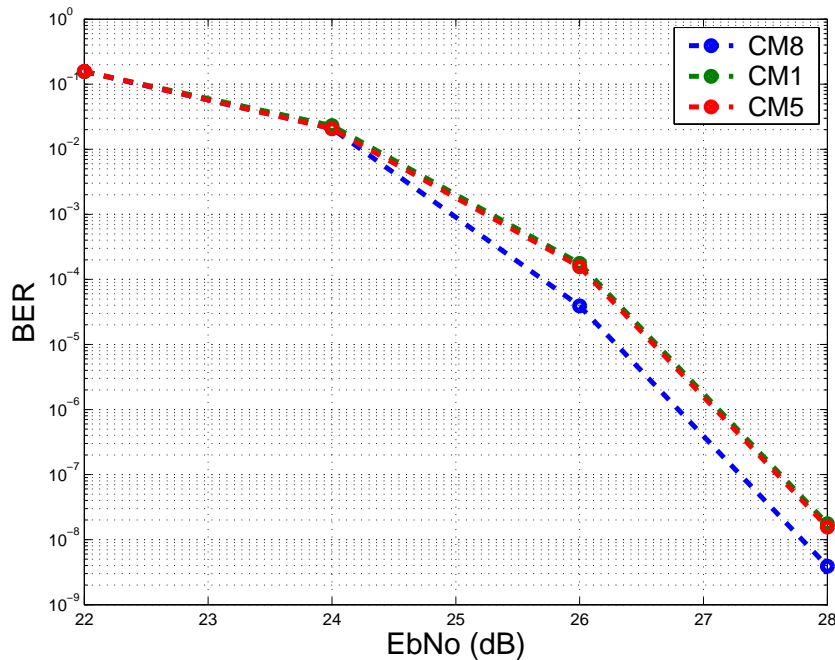

# MC-PPM Modulation

## SOPs

### ■ Time Division

- Configuration of SOPs
  - Self configuration of SOPs is possible

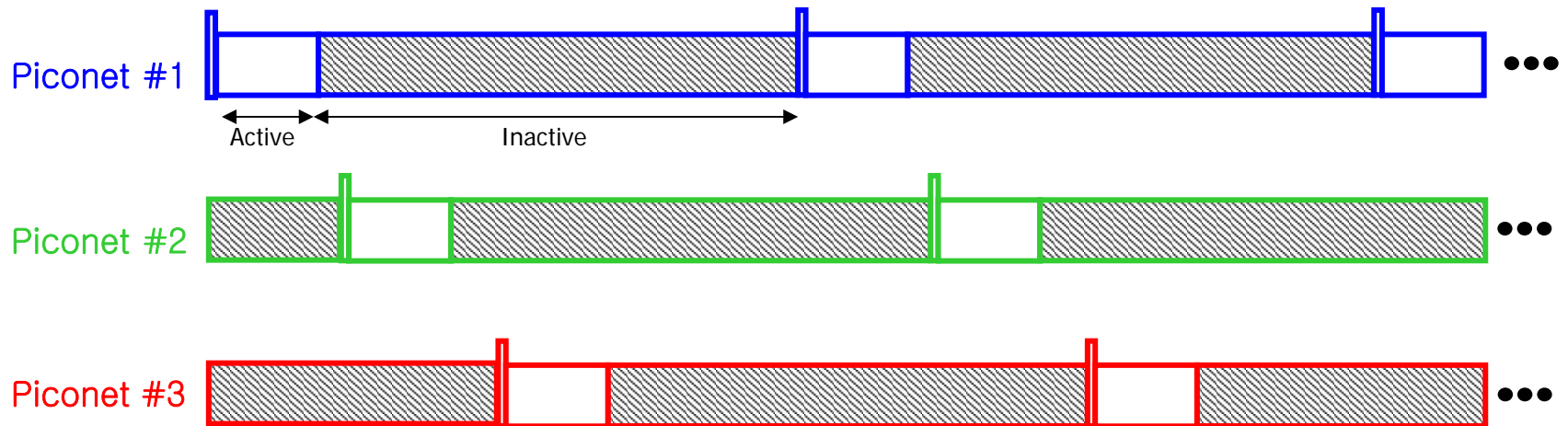

# MC-PPM Modulation

## SOPs

### ■ Self Configuration of SOP

- Passive Scan
  - Repeat scanning one channel
  - Usage
    - Starting a new piconet (FFD)
    - Association (FFD or RFD)

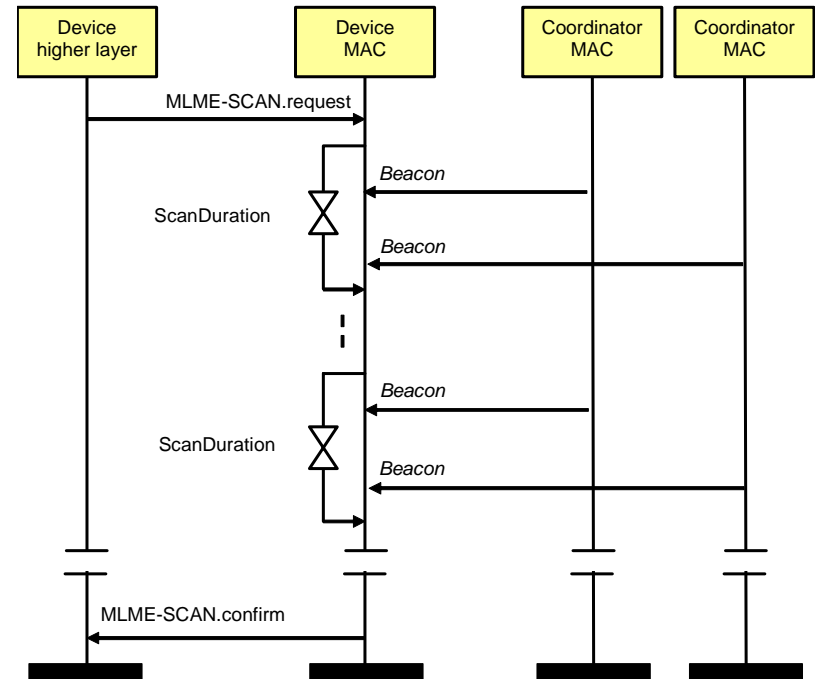

# MC-PPM Modulation

## Link Budget & Sensitivity

- Link Budget & Sensitivity based on MC-PPM

Parameter	(mandatory) Value at d=30m	(mandatory) Value at d=10m
peak payload bit rate	(457kb/s) [ L=3,Ns=8,Nr=1]	(457kb/s) [ L=3,Ns=8,Nr=1]
Average Tx power	-8.75 (dBm)	-8.75 (dBm)
Tx antenna gain	0 (dBi)	0 (dBi)
geometric center frequency of waveform	3.90 (GHz)	3.90 (GHz)
Path loss at 1 meter	44.5dB	44.5dB
Path loss at <i>d</i> m	29.54 dB at <i>d</i> =30m	20 dB at <i>d</i> =10m
Rx antenna gain	0 (dBi)	0 (dBi)
Rx power	-82.55 (dBm)	-73.01 (dBm)
Average noise power per bit	-117.4 (dBm)	-117.4 (dBm)
Rx Noise Figure	7 (dB)	7 (dB)
Average noise power per bit	-110.4(dBm)	-110.4(dBm)
Minimum Eb/N0 (S) [Ep/N0]	20 (dB)	20 (dB)
Implementation Loss (I)	5 (dB)	5 (dB)
Link Margin	2.85(dB)	12.39(dB)
Proposed Min. Rx Sensitivity Level	-85.4(dBm)	-85.4(dBm)

# MC-PPM Modulation

## Ranging

### ■ Scheme

- TOA/TWR -> Measurement of Roundtrip time

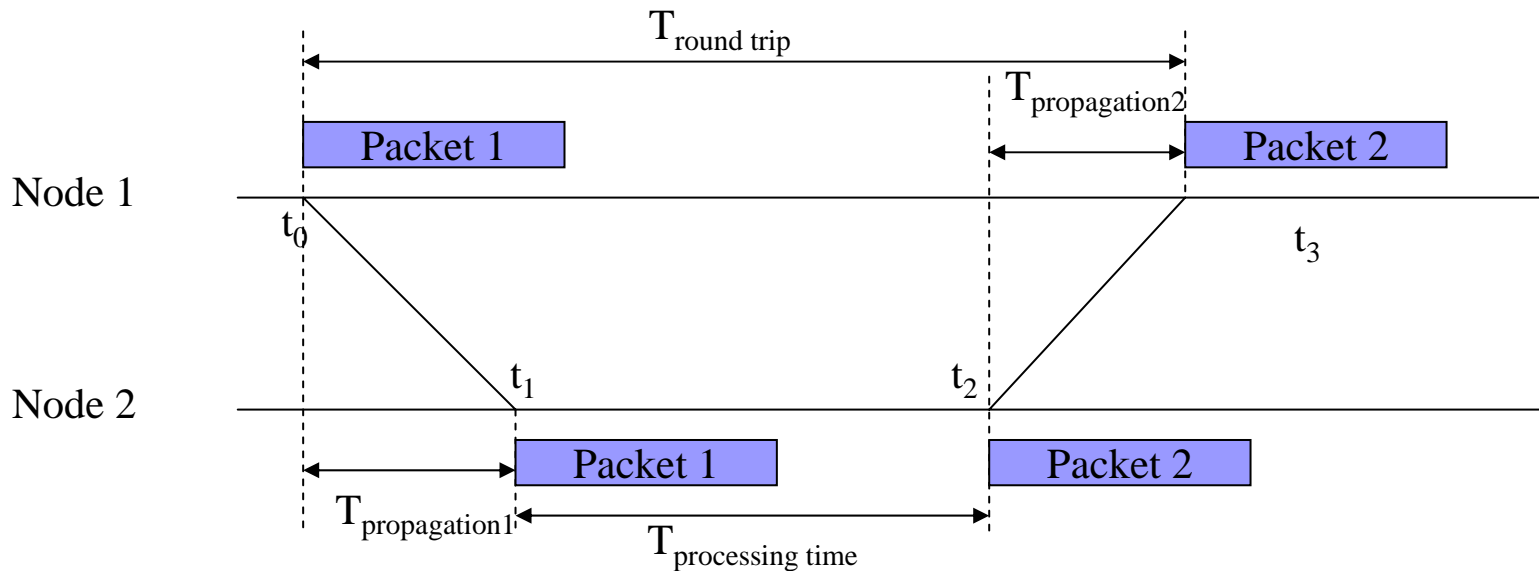

# MC-PPM Modulation

## Ranging

### ■ Performance

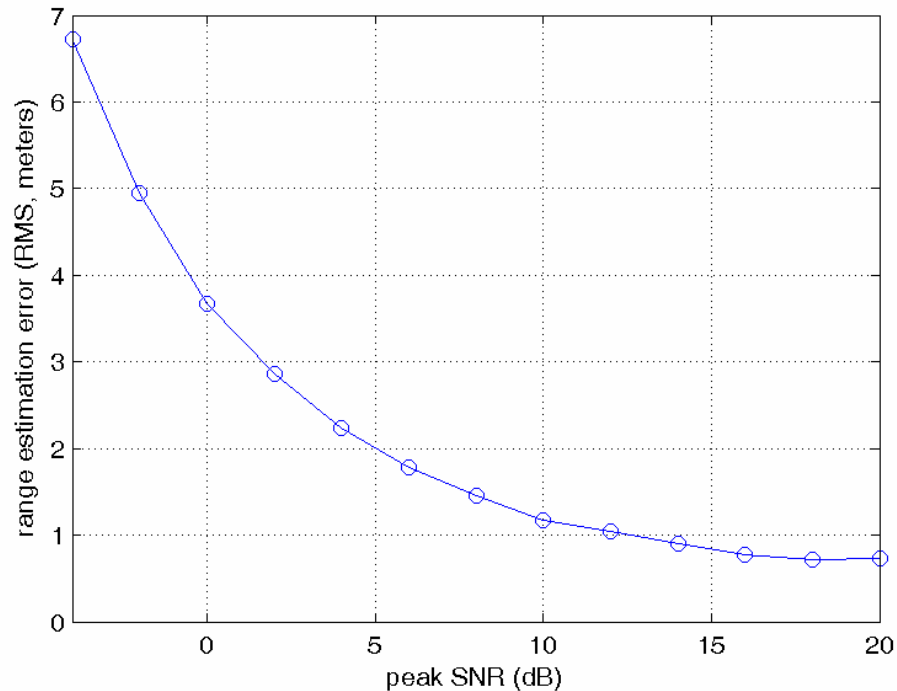

**802.15.4a channel (cm4)**

**Single user**

**No narrowband  
interference**

**Pulse width = 20ns**

**Integration time = 2ns**

**Pulse repetition period =  
200ns**

**Length of search region =  
40ns**

**Threshold level was  
determined relative to  
noise floor**

**A separate envelope  
detector for range  
estimation was employed**



# Backup Slides

# Tolerance of Components

- Capacitor, C1 and inductance, L → 20% tolerance.
- C2 and resistors, RE and R1 → 5% tolerance.

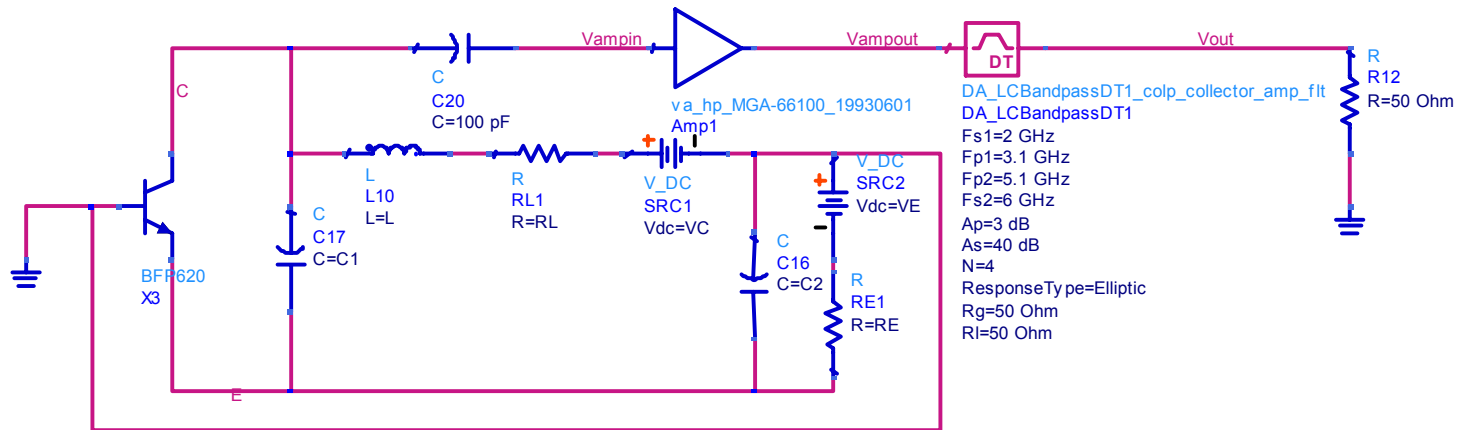

# Summary of Features

<b>Information carrier</b>	<b>Chaotic radio pulses</b>		
<b>Band division</b>	<b>3 bands within FCC Mask (3.1-5.1, 6.1-8.1 and 8.2-10.2 GHz)</b>		
<b>Channel bandwidth</b>	<b>2.0 GHz band or 4 channels with 500 MHz in each in the 2 GHz band</b>		
<b>Pulse duration</b>	<b>400 ns</b>		
<b>Individual bit rate</b>	<b>1 Kbps</b>	<b>10 Kbps</b>	<b>100 Kbps</b>
<b>Transmit power</b>	<b>-30 dBm</b>	<b>-20 dBm</b>	<b>-20 dBm</b>
<b>Battery life</b>	<b>2.5 year 100% duty cycle</b>	<b>2.5 year 10% duty cycle</b>	<b>2.5 year 0.1% duty cycle</b>
<b>Aggregated bit rate</b>	<b>Up to 5 Mbps</b>		

# Tiny Chaotic Transmitter

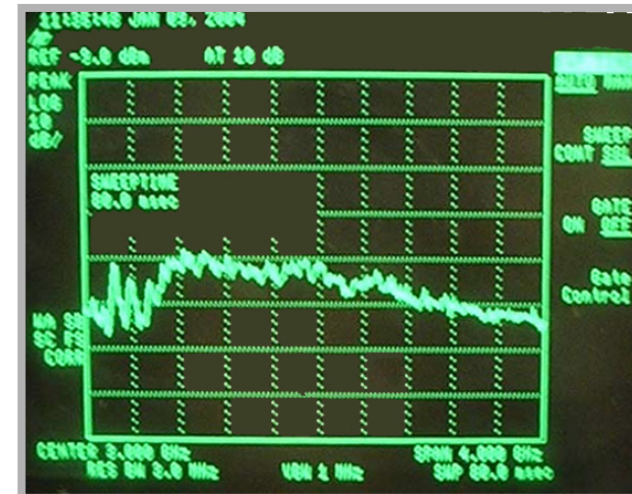
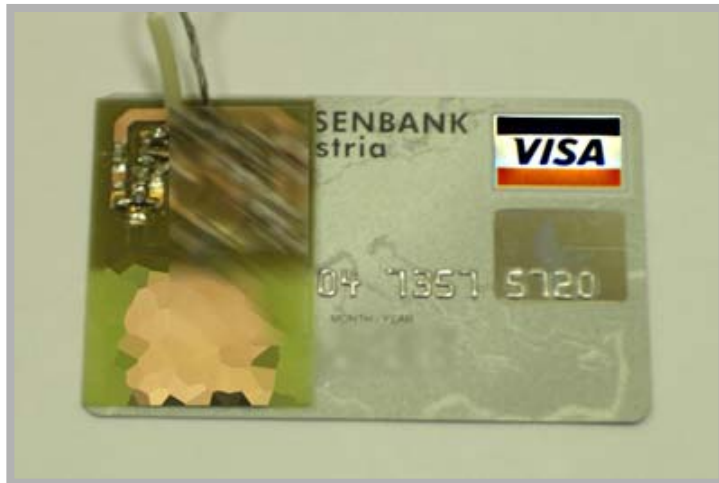

**Transmitter consists of:**

- chaos generator
- modulator
- antenna

**Frequency band - 2-4 GHz**

**Radiating power - 3-4 mw**

# DCSK Modulation

## SOP

### ■ System Block

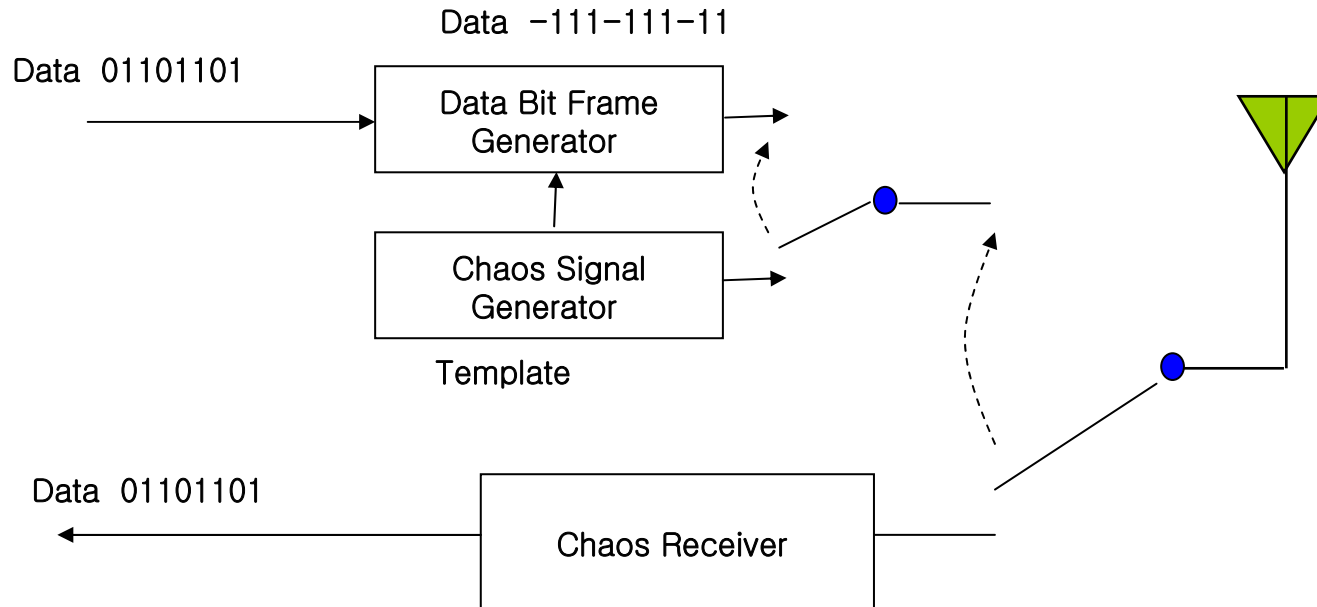

# DCSK Modulation

## SOP

### ■ Transmission

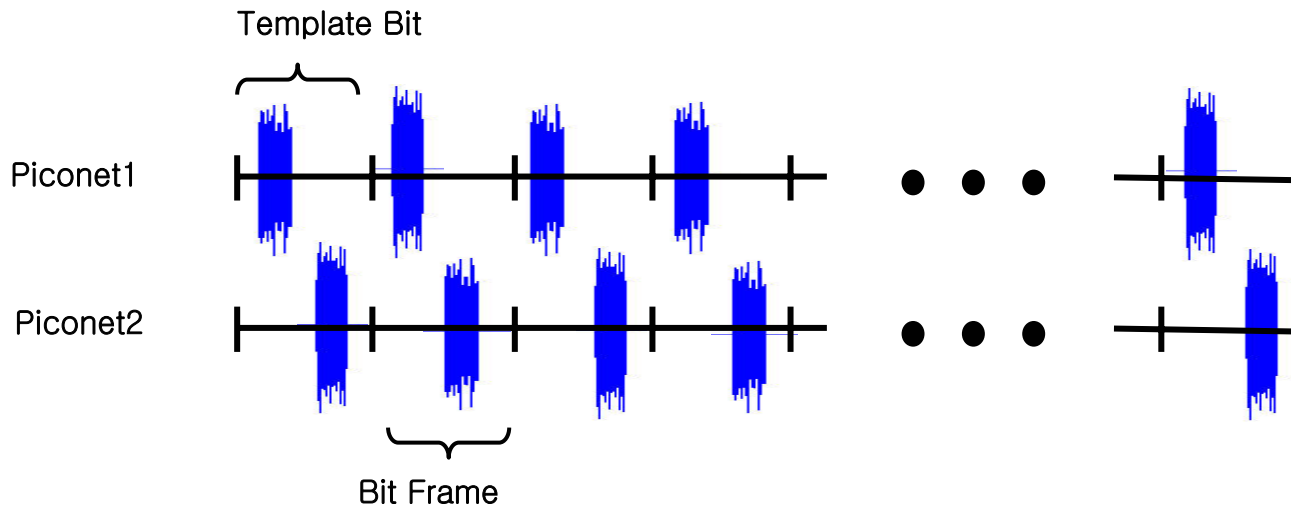
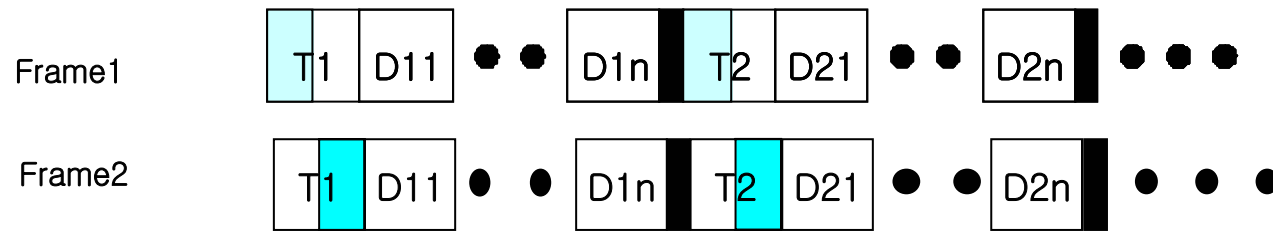

# DCSK Modulation

## SOP

### ■ Detail

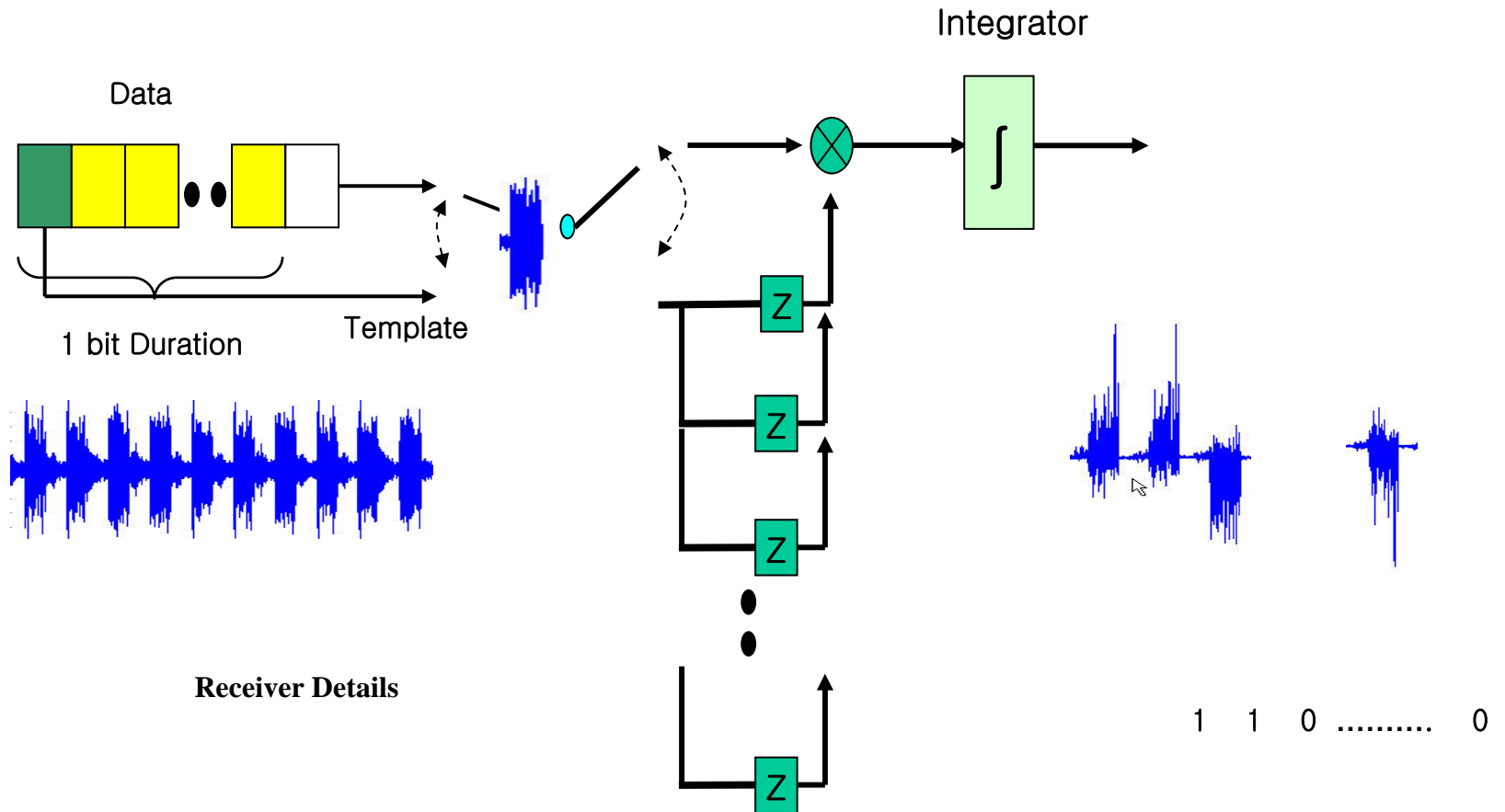

# DCSK Modulation

## SOP

### ■ Signal Processing

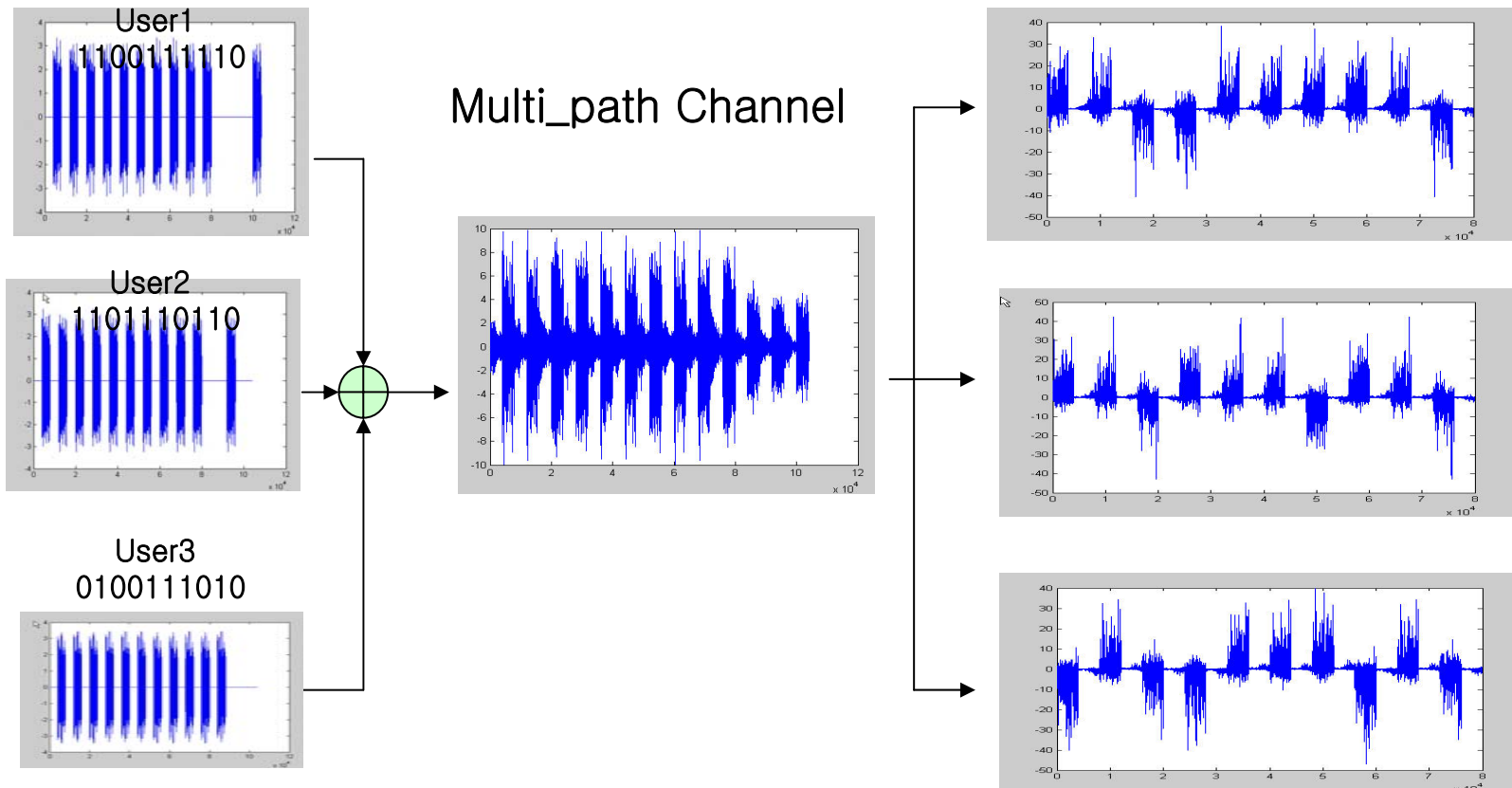



# DCSK Modulation

## Ranging

### ■ Block Diagram

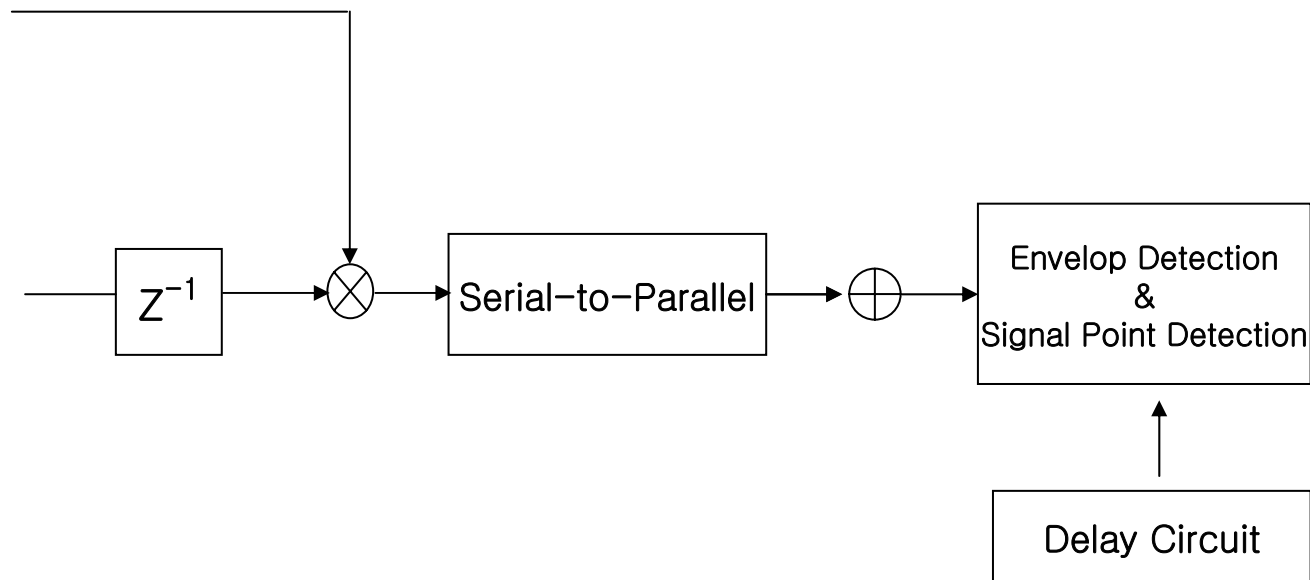

# DCSK Modulation

## Ranging

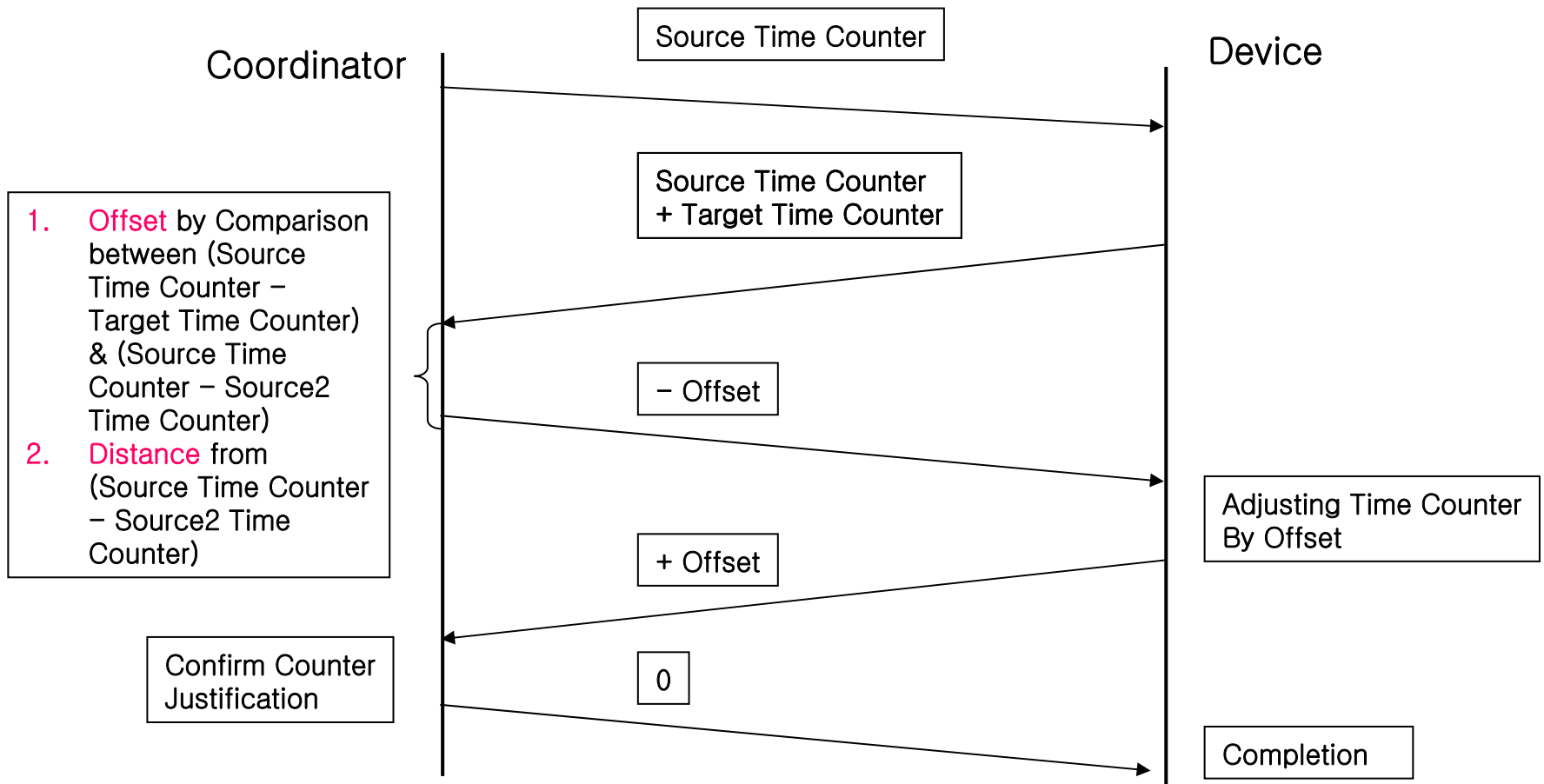

# DCSK Modulation

## Ranging

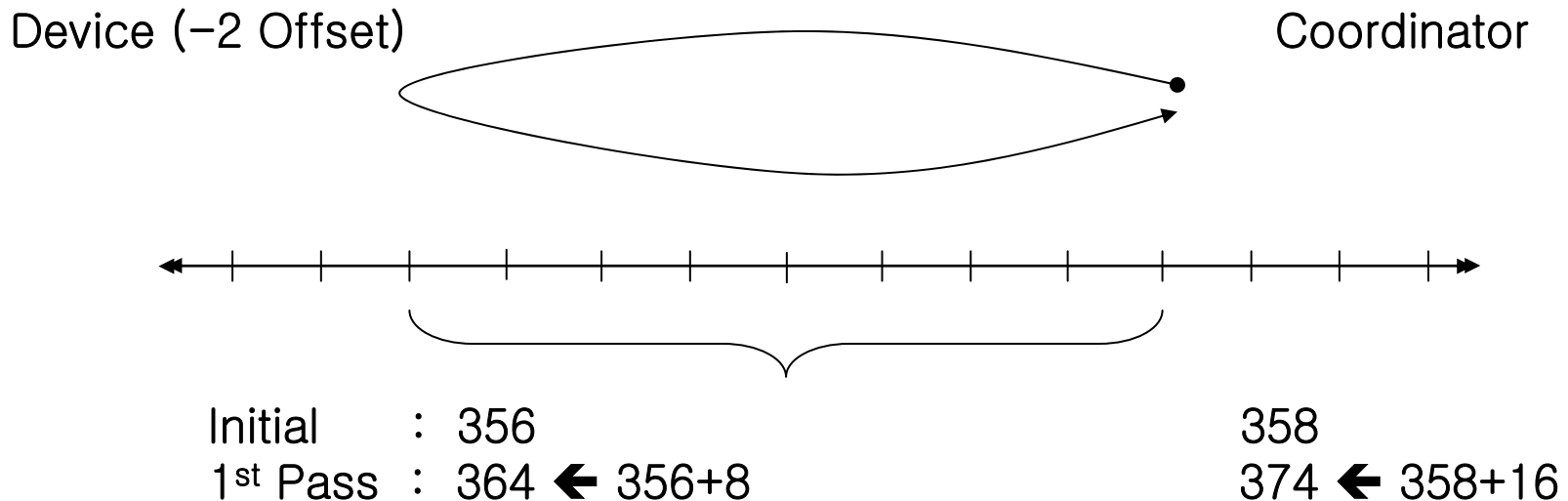

1. PNC recalculates Device Arrival time : 366 ← 358 + (16/2)
2. Compare value from 1 and Device : -2 ← 364 - 366
3. +2 Transferred as **-Offset**
4. 8 Kept for **Distance** between PNC and Device

# DCSK Modulation

## Location Awareness Special Mode

### ■ Timing Counter Fine Synchronization

- PNC disseminates special frame to inform Device of Location special mode
- Device acknowledges with its own timing count
- PNC compares its own count with Device's count, and extract an offset between them
- PNC sends negative offset in order for Device to compensate its timer
- Device informs PNC of all being set

# DCSK Modulation

## Location Awareness Special Mode

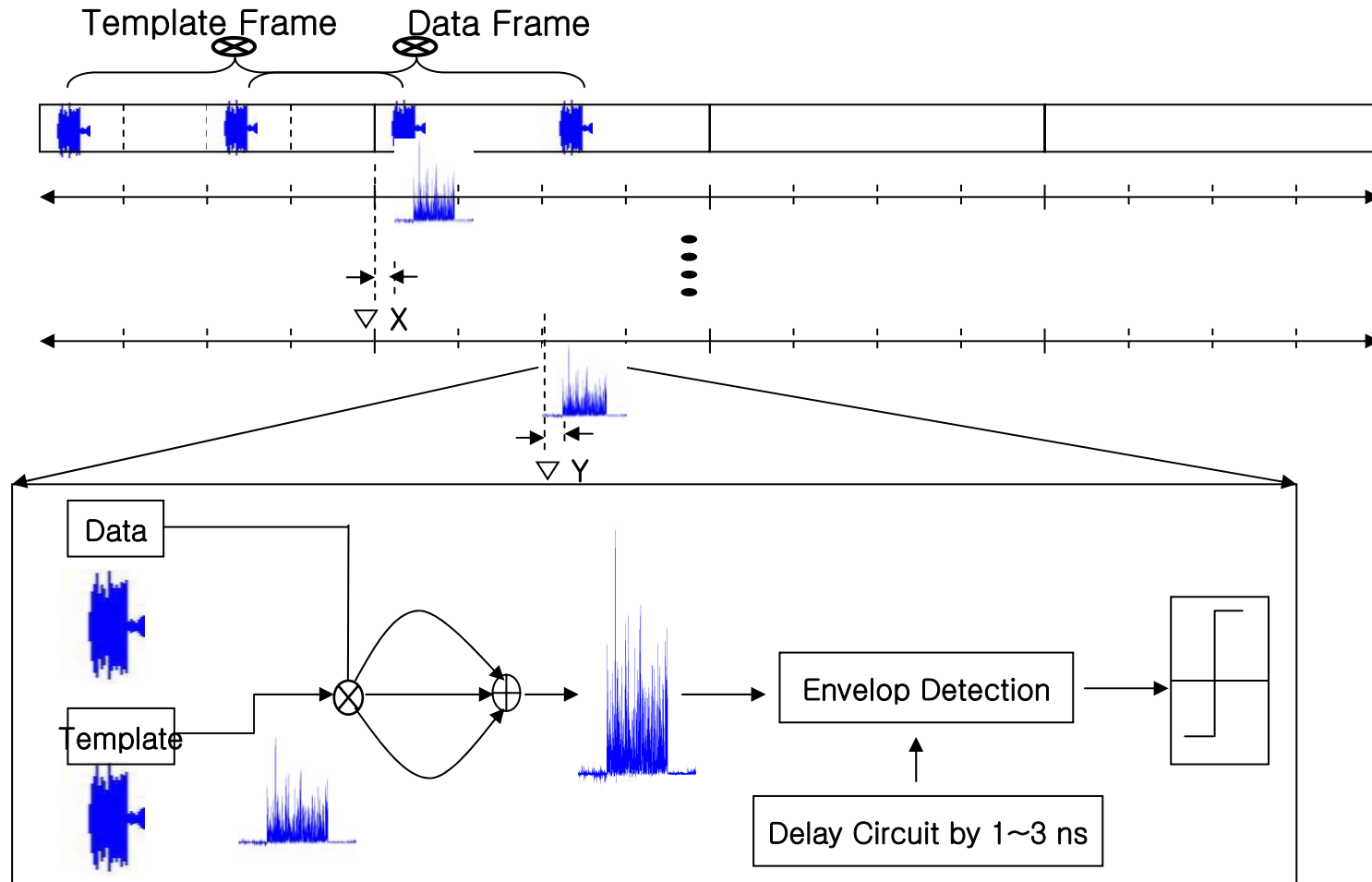

# DCSK Modulation

## Ranging

### ■ Fine Precision TOA Estimation

- Suggest Special mode different from Normal mode, which needs faster clock
- In special mode, Estimate how far Signal detached from fixed time slot with finer clock
- This obtained value returned with Response command to Request command from MAC

# DCSK Modulation

## Ranging

### ■ Delay Circuit

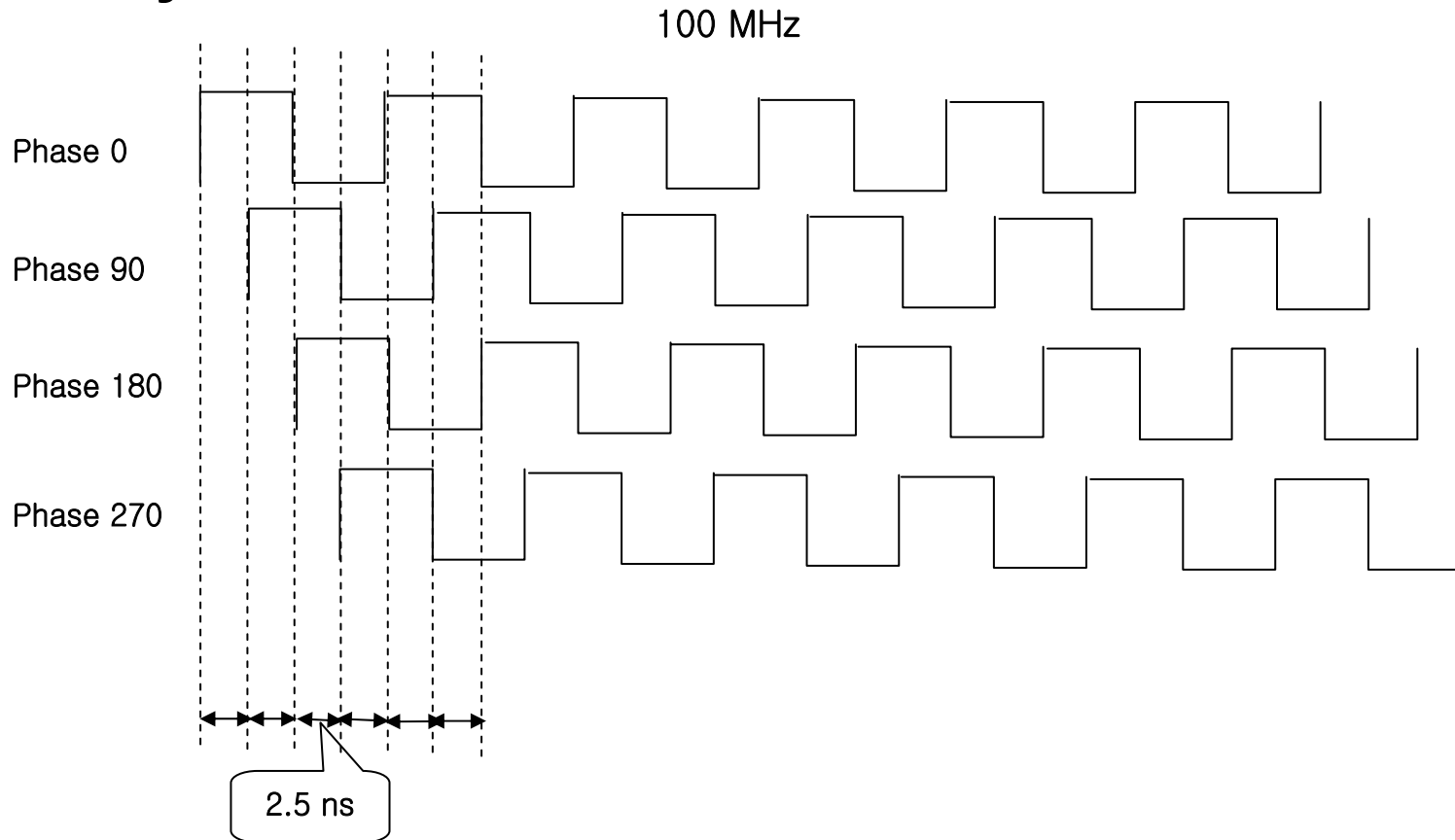

# DCSK Modulation

## Ranging

### ■ Simulation (BNR 16dB)

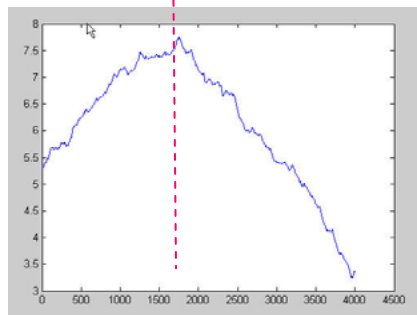
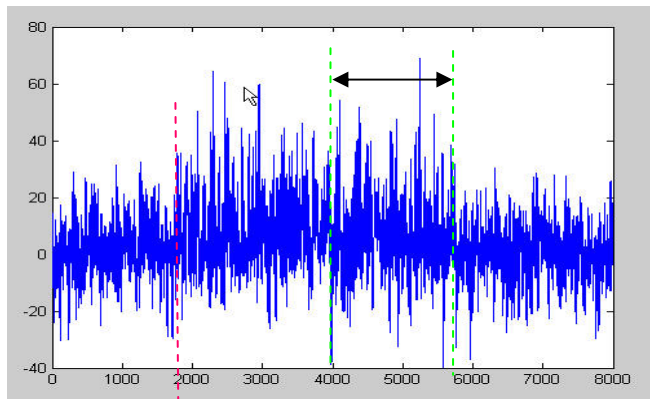

real distance : 13.118 meter  
2.5 ns precision distance : 12.750 meter  
Error : -0.367 meter

Maximum Index of Moving  
Average by duty cycle  
Duration will be converted  
to distance.

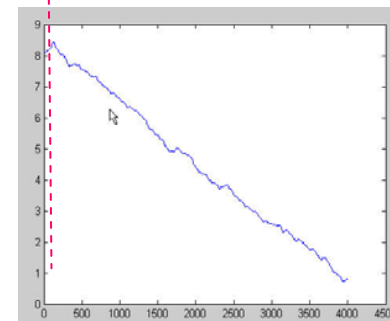
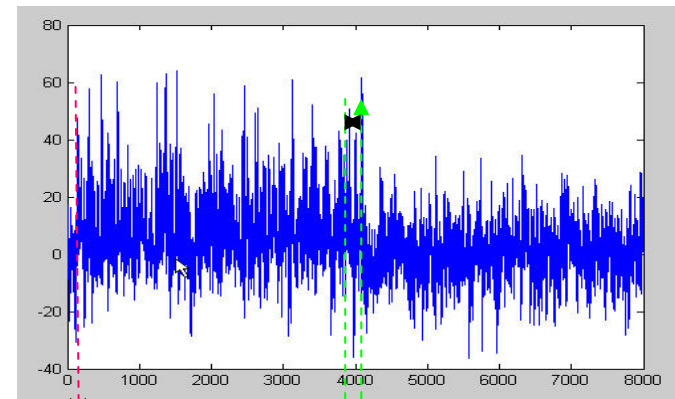

real distance : 0.968 meter  
2.5 ns precision distance : 0.750 meter  
Error : -0.218 meter