

Next Generation Positioning Overview and Challenges

Authors:

Name	Affiliation	Address	Phone	Email
Jonathan Segev	Intel		+972-54-2403587	jonathan.segev@intel.com
Peter Thornycroft	Aruba			p Thornycroft@arubanetworks.com
Brian Hart	Cisco			brianh@cisco.com
Naveen Kakani	CSR			naveen.kakani@csr.com
Venkatesan Ganesh	Intel			ganesh.venkatesan@intel.com
Liwen Chu	Marvell			liwenchu@marvell.com
Carlos Aldana	Qualcomm			caldana@qca.qualcomm.com

Motivation and purpose

- In previous contributions several useful usage models that are of commercial use for positioning have been presented.
- This contribution presents some of the challenges in enabling this set of usages for 802.11 based positioning and an overview of positioning techniques.

Why 802.11 Based Positioning?

- Positioning has symbiotic relation with data connectivity:
 - Positioning means nothing without contextual information.
 - Data connectivity improves with the addition of positioning.
- 802.11 based WLAN is almost ubiquitous in many indoor environments (malls, retail chains).
- Building on existing technology enables reuse:
 - Many of the use cases revolve around the smartphone (already packed with radios, reuse keeps complexity of actual device in check).
 - Reuse of connectivity technology shortens and simplifies technology development.

Symbiotic relationship between data and
positioning services

What is 802.11 Based Positioning?

- Indoor positioning major approaches:
 - Fingerprinting – a unique characteristic of the radio signal(s). Example: identify a position based on a set of RSSIs associated with APs.
 - Geometrical – a mathematical model of the signal propagation properties is created. A device uses this model to trilaterate/multilaterate/triangulate its position using measurements to derive its position.



$$r_1^2 = x^2 + y^2 + z^2$$

$$r_2^2 = (x - d)^2 + y^2 + z^2$$

$$r_3^2 = (x - i)^2 + (y - j)^2 + z^2$$

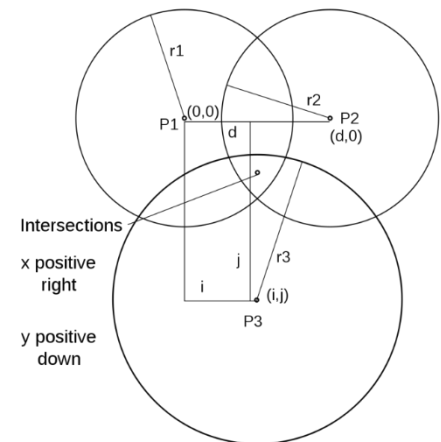

Positioning approaches - Fingerprinting

- A survey of the site is performed and “fingerprint” of the signals properties are taken; alternatively crowd sourcing might be used.
- Example: A device takes measurements and sends it to server. The server performs pattern matching trying to find the best matched position.



Positioning approaches – Fingerprinting

- Essentially any positioning technique can be used with fingerprinting, however RSSI fingerprinting variant is most suited (Rx only, AP scan already part of API).
- Accuracy improves as range to AP reduces.

RSSI example:

Pro's	Con's
Simple to implement.	Sensitive to noise and channel variations.
Easy to crowd source.	Less dynamic.
No need for a known AP location	Not well suited for proximity usages.
Minimal/no impact on medium usage.	Changes in the environment requires many DB updates.
Geopriv is easy to achieve with downlink RSSI fingerprinting.	Dependent on constant device Tx PWR.
	Exposed to replay attack.

Positioning approaches - Geometrical

- A mathematical model of the signal propagation properties is created.
- Some examples: FTM (trilateration), RSSI (trilateration or multilateration), AoA/AoD (triangulation).

$$r_1^2 = x^2 + y^2 + z^2$$

$$r_2^2 = (x - d)^2 + y^2 + z^2$$

$$r_3^2 = (x - i)^2 + (y - j)^2 + z^2$$

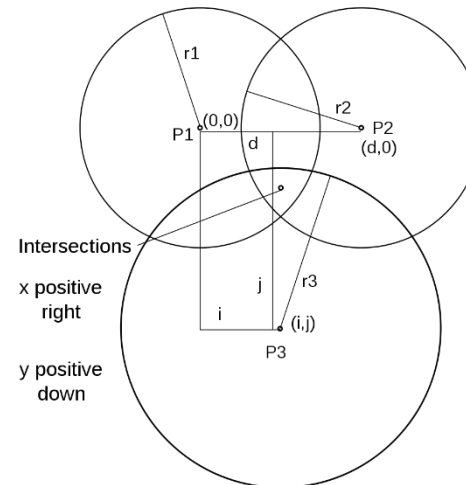

* Z is not depicted by figure as it is out of page.

Positioning approaches – Geometrical

FTM example:

Pro's

Overcomes the need for a site survey.

Fewer updates to AP DB needed

Suited to proximity usages

Measurements have low variance (less susceptible to noise).

Con's

AP location has to be known.

The mathematical model of the signal propagation is not always accurate/optimized.

Hindered by NLOS (Non Line Of Sight) or NNLOS (Near NLOS) channel conditions giving a wrong sense of range.

An accurate measurement is essential, 1nsec inaccuracy translates to 0.3m.

Evolution of 802.11 Based Positioning

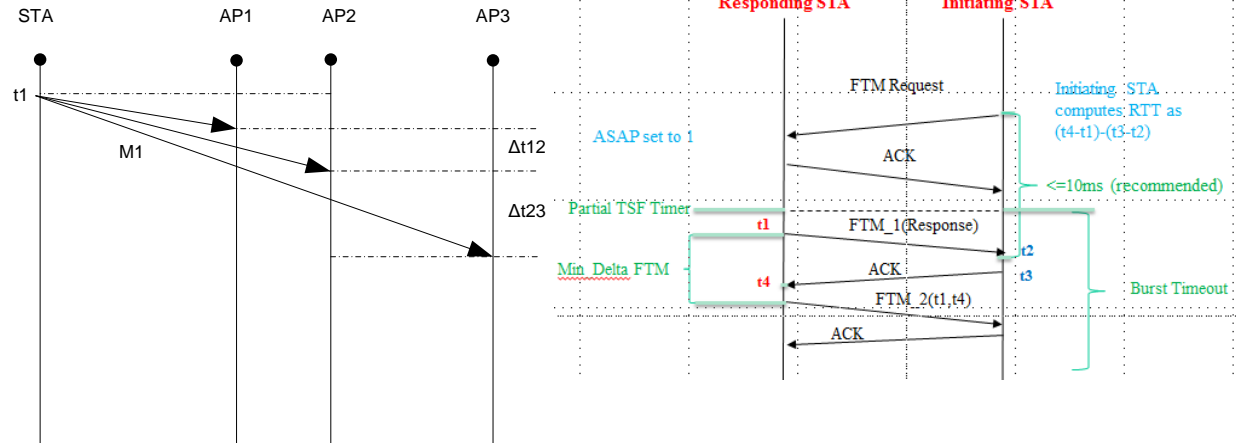

REVmc Location Support

- **Main items addressed by FTM introduction to REVmc:**
 - 1:N operation - AP STA: non AP STA is the lead usage model.
 - Multi channel operation: AP STAs have a fixed operating channel while non AP STA moves between AP STA's channels.
 - unassociated operation mode, as multiple ranges are required to obtain a single fix.
 - Support for AP Location DB protocol.

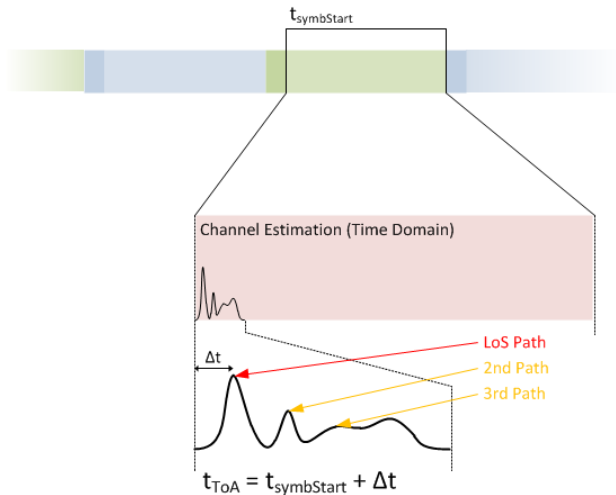

$$r_1^2 = x^2 + y^2 + z^2$$

$$r_2^2 = (x - d)^2 + y^2 + z^2$$

$$r_3^2 = (x - i)^2 + (y - j)^2 + z^2$$

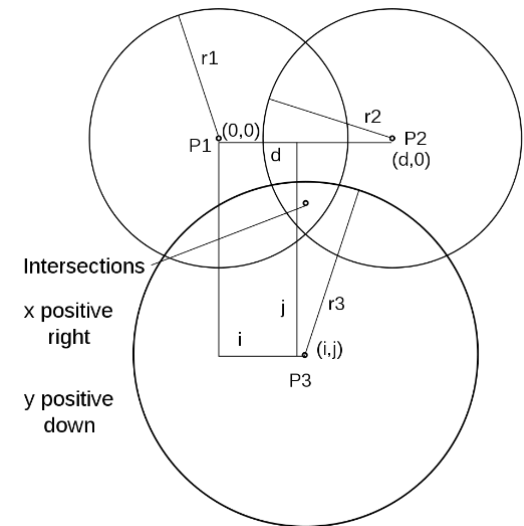

What's next then?

- In previous* contributions we've seen a set of new usage models of commercial value:
 - Micro geo-fencing moving from $<1\text{m}$ to $<0.1\text{m}$.
 - Direction finding.
 - Improving scalability and reducing overhead.
 - High Accuracy Positioning
 - Enable the use of FTM $<1\text{ GHz}$ frequency bands

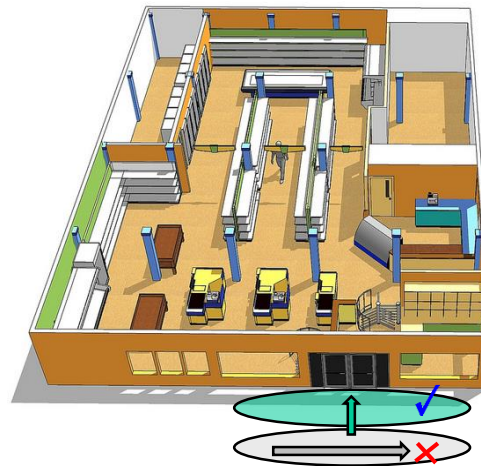

* 11-14-1193/01 – Beyond Indoor Navigation by Jonathan Segev, Carlos Aldana et-al
11-14-1235/r0 – Scalable Location by Brian Hart, Peter Thornycroft and Mark Rison.
11-14-1263/r0 – Direction Finding Positioning by James Wang, Gabor Bajko et-al

Improved accuracy – moving from $<1\text{m}$ to $<0.1\text{m}$

- **Problem definition:**

- 1st generation products are focused on indoor navigation but as technology adoption increases so does the demand for performance.
- Micro location becomes of interest, $\sim 0.1\text{m}$ accuracy opens up a new set of usage models:
 - Micro geo-fencing at store entrance.
 - Guide me to product on the exact shelf.
 - Identify user preference and offer useful valuable service.



Direction finding

- **Problem definition:**
 - People visiting a museum/store would like to:
 - Get guidance on exhibits in an exhibition, to articles on a high shelf.
 - Articles may not be accessible but there's a LoS between user and article.
 - A manager in a store would like to:
 - Provided additional information to clients as they enter the store.

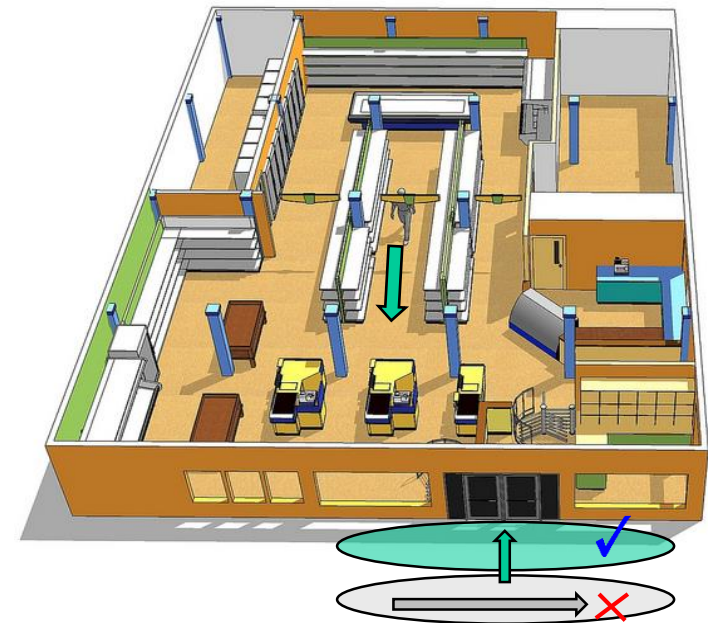

Improving scalability and reducing overhead

- **Problem definition:**

- People would like to get directions to their seat in the stadium, or their gate at an airport.
- Current protocol requires ~6 frames per fix, per STA, possibly using basic rate (limited link adaptation, trilateration).
- Some work have to assess* medium usage using FTM has been done.
- Heavily crowded scenarios show substantial** impact on medium usage with FTM.



* 11-12-1249-04-000m-802-11-2012-cid-46-47-48 by Carlos Aldana et-al.

** 11-13-0072-01-000m-client-positioning-using-timing-measurements-between-access-points by Erik Lindskog, Naveen Kakani et-al.

High Accuracy Positioning

- **Problem definition:**
 - I'd like to play augmented reality on my gaming machine possibly connected to my WLAN.
 - Possibly wearing special glass with sensors on my wearable devices.
 - Centimeter accuracy required for new age user experience.
 - LOS environment usage scenario is possible.



Submission



Slide 15

Jonathan Segev, Intel

Enable the use of FTM <1 GHz frequency bands

- **Example of usage and benefits of FTM in Sub 1 GHz WLAN:**
 - Reduce cost of operation when logging Sub 1 GHz enabled smart meter installation locations*
 - Smart meters can do trilateration/triangulation with Access Points to have automated location logging and avoid human errors.
 - Use of Sub 1 GHz enabled tags can be used both for indoor and outdoor locationing
 - Track family members.

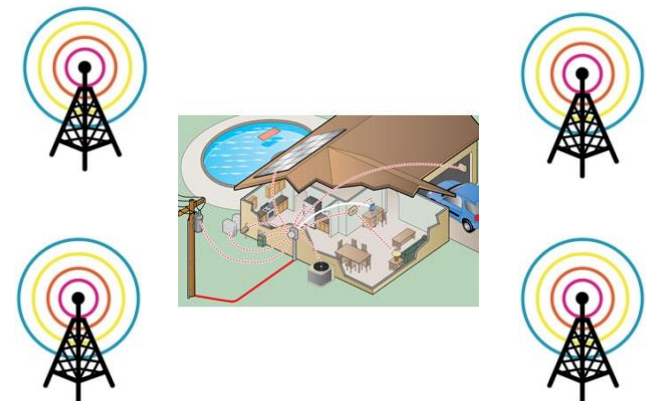

*[15-14-0391-00-004r-technical-guidance-document-input-for-ami.pptx](#)

Challenges of using 802.11 Based Positioning - moving from <1m to <0.1m

- The local timing function in 802.11 is accurate to within $\pm 20\text{ppm}$ (phy dependent).
- How does this affect the RTD measurement?
 - Measurement frame of $\sim 100\mu\text{sec}$
 - SIFS $\sim 16\mu\text{sec}$
 - ACK frame $\sim 70\mu\text{sec}$

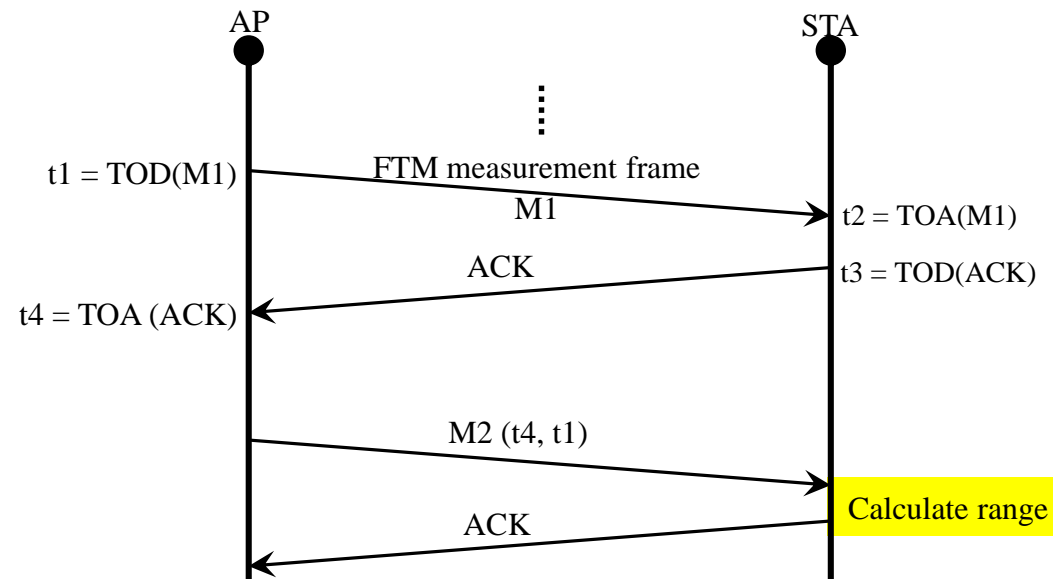

Challenges of using 802.11 Based Positioning - moving from <1m to <0.1m

- Measurement frame of ~100usec
- SIFS ~16usec
- ACK frame ~70usec
- Diagram below describes events at the antenna ports.

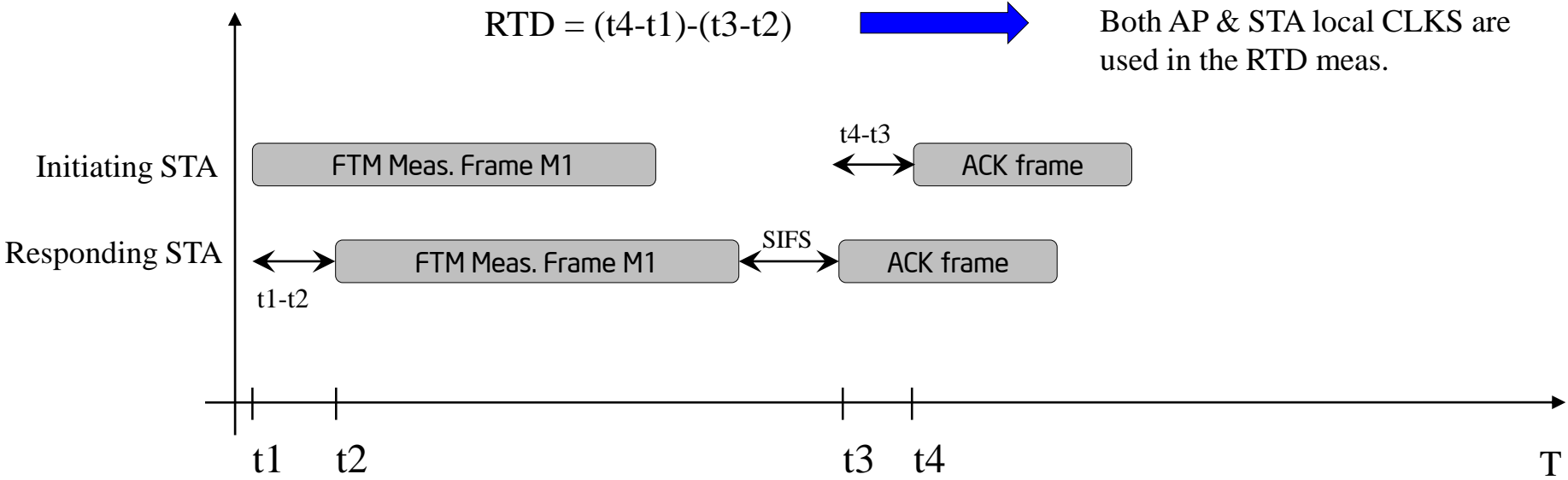

Challenges of using 802.11 Based Positioning - moving from <1m to <0.1m

- t_1 and t_4 are measured by STA 1 using CLK1 w/ accuracy PPM1 marked t_1' , t_4' respectively.
- t_3 and t_2 are measured by STA 2 using CLK2 w/ accuracy PPM2, marked t_3' , t_2' respectively.

$$\text{RTD} = (t_4' - t_1' + \Delta_1) - (t_3' - t_2' + \Delta_2)$$

\Rightarrow the measurement can be up to $\Delta_1 + \Delta_2$ off from the actual value.

Δ_1 is measured over $M1 + \text{SIFS} + \text{RTD}$ @ PPM1

Δ_2 is measured over $M1 + \text{SIFS}$ @ PPM2

$M1 = 100\text{usec}$

$\text{SIFS} = 16\text{usec}$

$\text{RTD} \ll M1, \text{SIFS}$

Worst case scenario: $\text{PPM1} = -\text{PPM2} = 20\text{ppm}$

$\Rightarrow \Delta_1 + \Delta_2 = \sim(M1 + \text{SIFS}) * (2 * \text{PPM1}) * C \sim 1.4\text{m}$

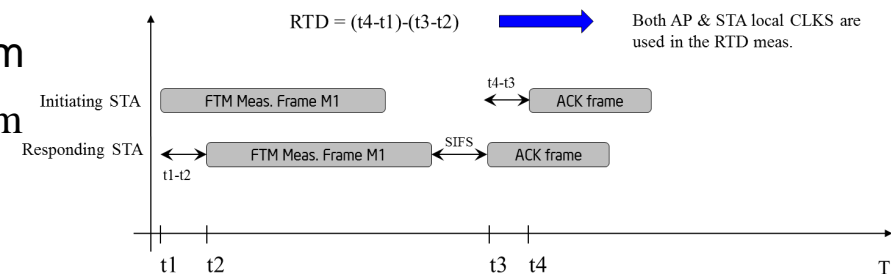

Challenges of using 802.11 Based Positioning - moving from <1m to <0.1m

- 1st generation mitigation:
 - Estimate time difference using a single clock rather than two non dependent ones.
 - 20ppm is the upper bound, better clock yields better accuracy.
 - Doppler is of lower importance.

$$\text{RTD} = (t4' - t1' + \Delta1) - (t3' - t2' + \Delta2)$$

$$\Rightarrow \Delta1 + \Delta2 = \sim(M1 + \text{SIFS}) * (\text{PPM1}) * C \sim 0.7\text{m}$$

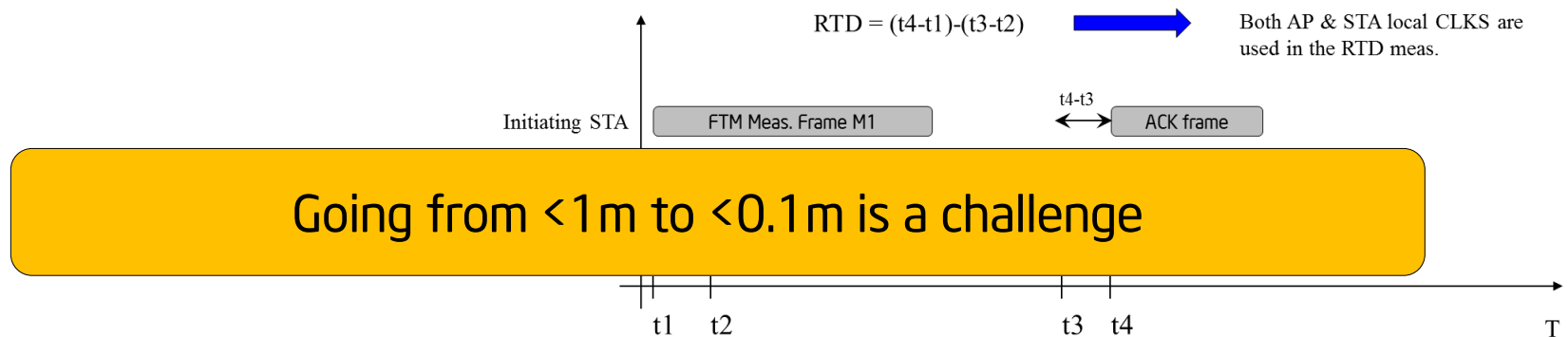

Challenges of using 802.11 Based Positioning - moving from $<1\text{m}$ to $<0.1\text{m}$

- 2nd generation improvement possible solutions:
 - Using of 802.11ad (shorter packets yields smaller drift), but set additional challenges.
 - Usage of mid-amble or post amble greatly reducing $t4-t1$ interval which is the main cause for the drift.

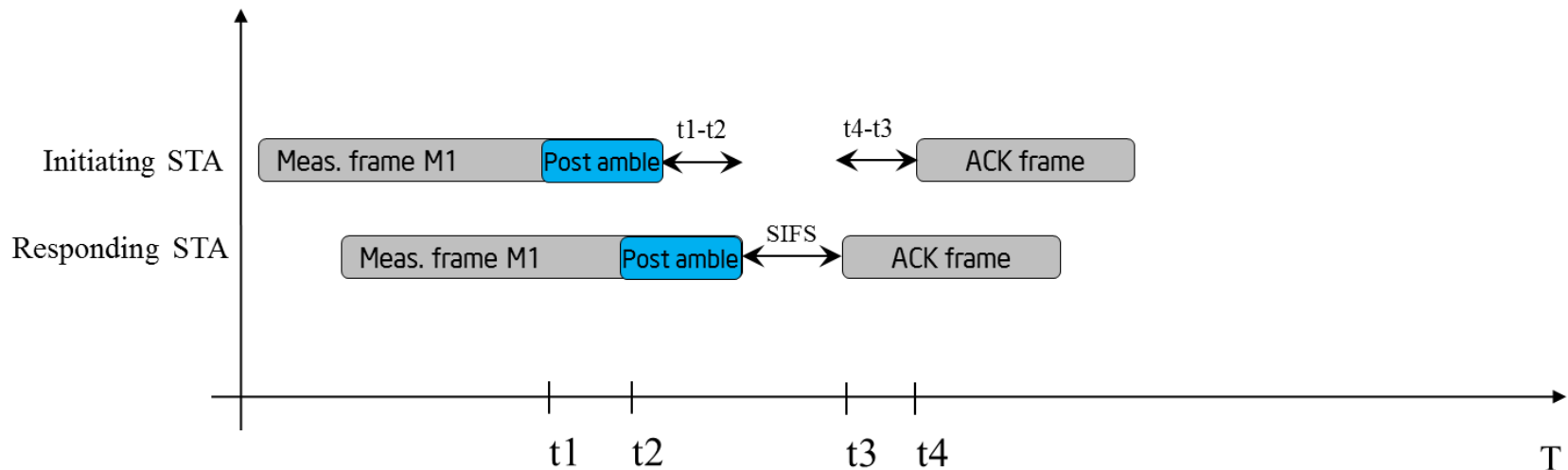

Challenges of using 802.11 Based Positioning - moving from <1m to <0.1m

- NLOS and NNLOS channel conditions increases the likelihood of having a wrong sense of range due to undetected first path.
- These play a role when moving to the higher accuracy resolution and for proximity usages:
 - Outliers harder to detect.
 - Usage of MIMO techniques may help.
 - Signals' properties in the 60GHz band presents both an opportunity and a challenge.

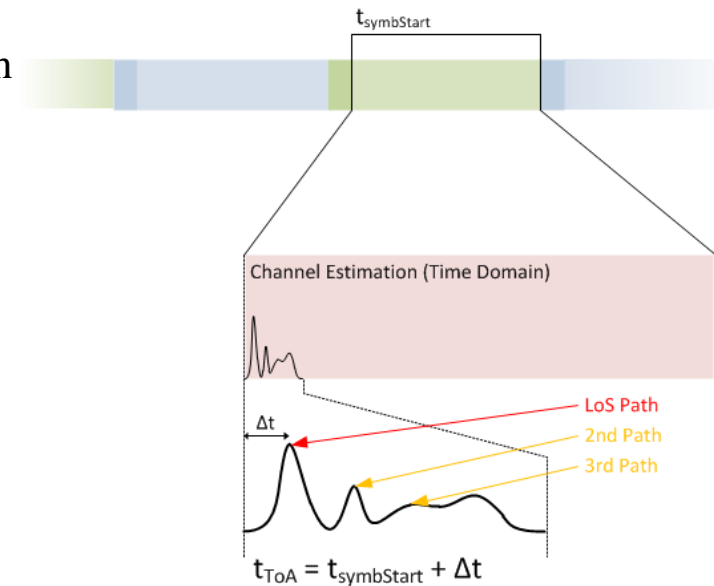

Challenges of using 802.11 Based Positioning - Scalable Positioning

- FTM has a high overhead:
 - Minimum of 6 messages required per single fix per AP.
 - Minimum of 4 APs required per single fix.
 - The medium usage is linearly dependent by the number of positioning STAs.
 - We've seen* before that in dense environments this becomes infeasible and that an infrastructure broadcast protocol might be better suited.

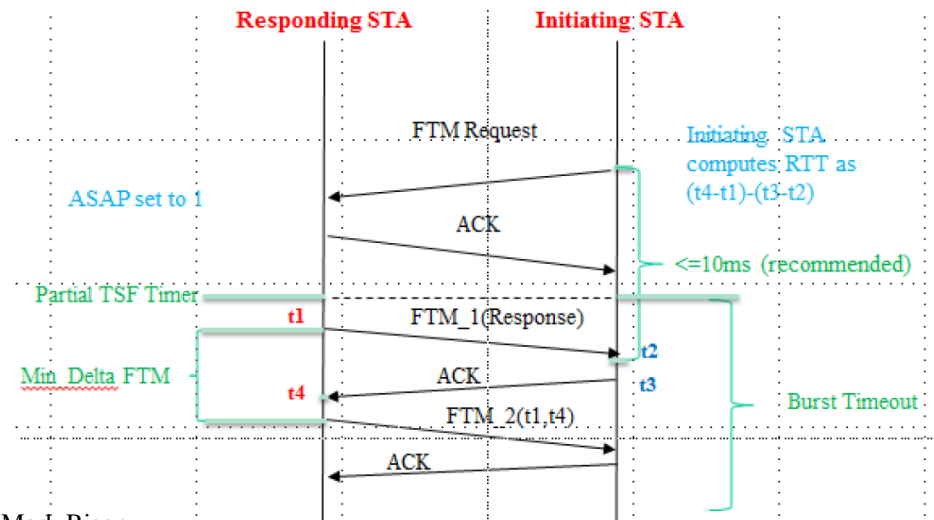

* 11-14-1235/r0 – Scalable Location by Brian Hart, Peter Thornycroft and Mark Rison.

Challenges of using 802.11 Based Positioning - Scalable Positioning

- AP STA will need to communicate its intent and preference to its peers and indicate it to the positioning STAs in a form which is independent of number of positioning STAs.
- Positioning STA may or may not be associated (use case dependent).
- Larger BWs provides better channel resolution, at the expense of co-channel interference.
- Acceptable deployment uses multi channel deployments to reduce interference, which means inter AP communication will be needed to indicate their absence to associated STAs in a transparent/backwards compatible way.

Summary

- We've described a new set of useful usage models that are of commercial use and interest.
- We've described the challenges and area of technical development that are extension of existing technology in 802.11.
- REVmc has enhanced the support for indoor positioning which will likely lead to implementations and market adoption in the near future.
- The group should now take the next step to extend the positioning support, and this should be done in a dedicated SG.

Straw poll - 1

Do you think next generation positioning would be a useful area for 802.11 to study?

Y:

N:

A:

Backup

Improved accuracy moving from $<1\text{m}$ to $<0.1\text{m}$

- **Current std. overview**

- Current technology has a theoretical limitation of 0.7m with real world scenarios bringing it to 2-4m depending on environment.

- **Shown:**

- Current technology.
- Ray trace simulation.
- 40Mhz BW.
- 5 APs
- Mix of dry walls, wood and metal frames.
- No MIMO (1x1 antenna scheme).
- Basic trilateration – no outlier handling.
- Simulated thermal and receive noise

