

NFPA 70E – 2015

Jim Bowen
Aramco
IEEE CED
Spring 2016

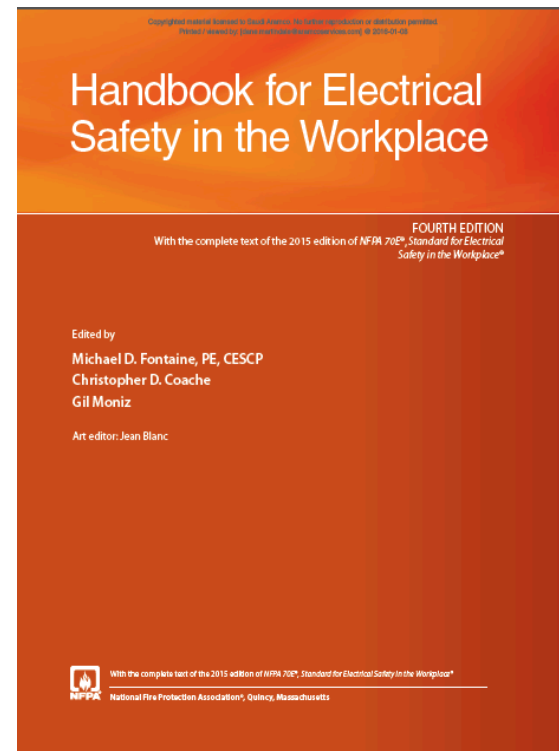

Article 90

Introduction

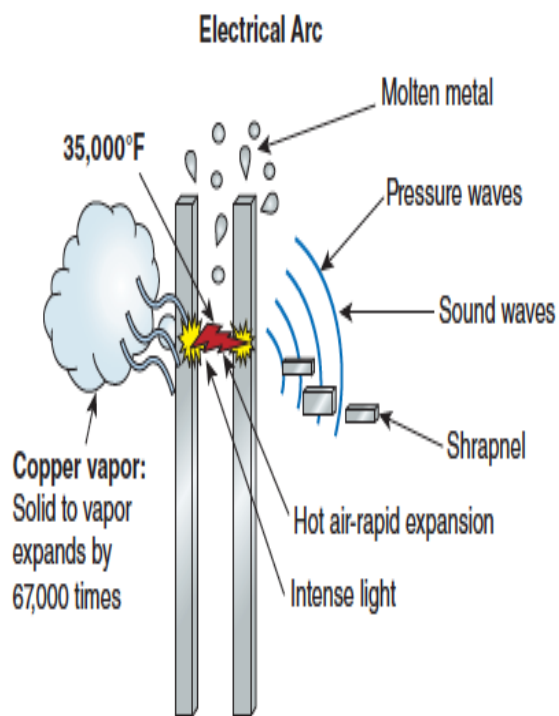

- The 2015 edition of NFPA 70E reflects a major shift in how stakeholders evaluate electrical risk.
- New definitions Article 100, including Hazard, Hazardous, Risk , and Risk Assessment .
- Changing “arc flash hazard analysis” to “arc flash risk assessment,”
- Changing “shock hazard analysis” to “shock risk assessment,”
- Changing “electrical hazard analysis” to “electrical hazard risk assessment,” and
- Changing “hazard identification and risk assessment” to “risk assessment.”

Changes to focus



- Safety-related maintenance requirements were added to the Scope
- Clarify that training and auditing are equally important safety-related work practices.

[90.2(A)]

Changes Eliminate Bare Hand



- The definition of Bare-Hand Work and all references to bare-hand work were removed.
- Considered to be a “utility type” line work

Changes Qualified Person

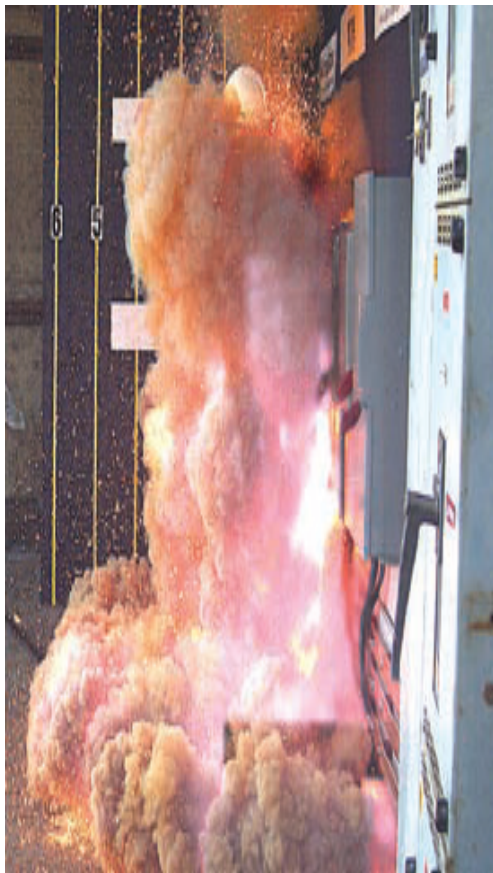

- The definition for Qualified Person was revised to correlate the definition with OSHA 1910.399 Note 2.
[100]
- Demonstrated
- Qualified for one piece of equipment but not another

Changes To Approach Boundary



- Prohibited Approach Boundary was deleted.
- Previous changes used the limited approach boundary or arc flash boundary for “triggering” requirements made the term unnecessary.

Changes



- An electrical safety program must now include elements that consider condition of maintenance. [110.1(B)]

AUDIT Requirements



- Audits of field work to verify compliance with the procedures of the electrical safety program must be performed at intervals not to exceed 1 year. [110.1(I)(2)]
- Electrical Safety Program. shall be audited intervals not to exceed 3 years.

Changes

Temporary Grounds

- The location, sizing, and application of temporary protective grounding equipment is part of the employer's job planning. [120.3(A)]

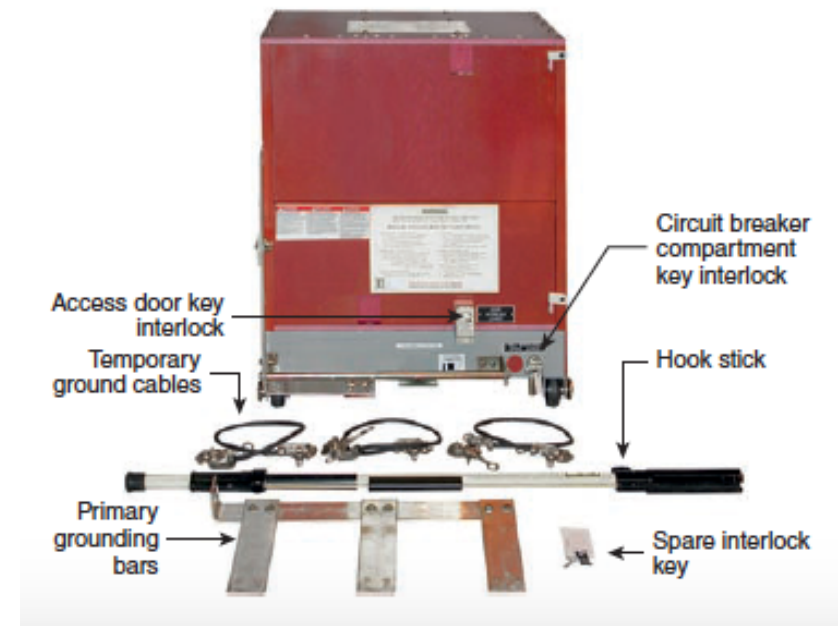

Changes

Normal Operation

- New requirements clarifying where normal operation of electric equipment is permitted were added.
- The equipment must be properly installed and maintained, equipment doors closed and secured, and all covers in place and secured, and there is no evidence of impending failure. [130.2(A)(4)]

Changes

Calc and
Table
method of
obtaining
PPE

- The incident energy analysis method (Calc) or arc flash PPE categories method (Table) for the selection of PPE, but not both.
- Clarifies that the results of an incident energy analysis to specify an arc flash PPE category in Table 130.7(C) (16) is not permitted.
[130.5(C)]

Changes

Doc. and Updating

- Field-marked equipment labeling requirements were revised to require the label to be updated where the arc flash hazard risk assessment identifies a change that renders the label inaccurate.
- The documentation, installation, and maintenance of the field-marked label is the responsibility of the owner of the electrical equipment. [130.5(D)]

Changes

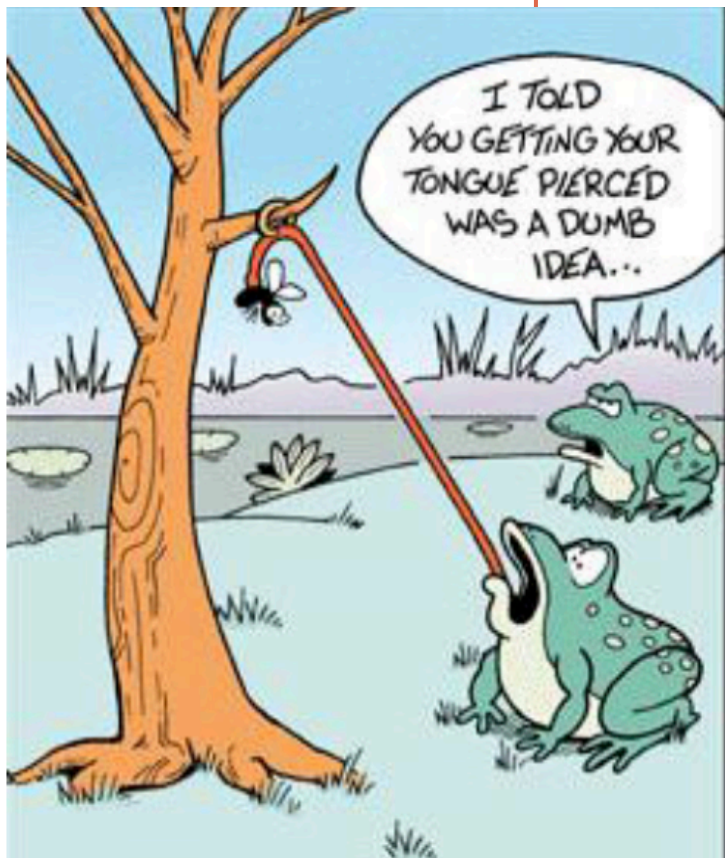

- Conductive articles shall not be worn within the restricted approach boundary or where they present an electrical contact hazard.
[130.6(D)]

Changes

Table

Method for determining PPE

- A new task-based table combines the separate ac and dc tables previously used
- The new table lists the task, equipment condition, and arc flash PPE required. It utilizes a simple yes or no format if arc flash PPE is required.

[130.7(C)(15)(A)(a)]

Changes

Table
Method

- New equipment-based tables were added for determining the arc flash PPE category
- Table 130.7(C)(15)(A)(b) for ac systems and Table 130.7(C)(15)(B) for dc systems.

Changes

PPE Definitions

- Hazard/risk category 0 has been removed from Table 130.7(C)(16).
- Hazard/risk category will be PPE category.
- If there is no arc flash hazard, then no arc flash PPE is required and it is therefore not necessary on a table devoted to PPE. [Table 130.7(C)(16)]

Changes Insulated Tools

1' for 600 V

2'2" for
2300V to
15kV

2'7" for 15.1
to 36kV

- The criterion for employees to use insulated tools or handling equipment has been changed from the limited approach boundary to restricted approach boundary. [130.7(D)(1)]

Shock Hazard

If this was
2300VAC



Voltage rated gloves



Protect the Person



Shock Protection

"#" indicates US ANSI voltage class
"00" rated 500 volts;
"2" rated 17,000 volts

Arc Flash Protection











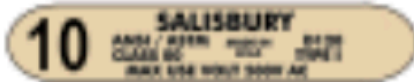

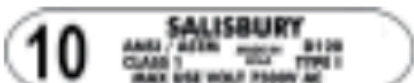

Class 00 Electrical Glove Kit

Protective Rubber Equipment Labeling Chart

for Salisbury Linemen's Natural Rubber and SALCOR® Rubber Protective Equipment

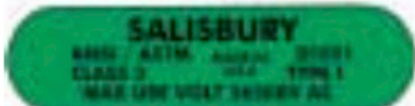
Class Color	Proof Test Voltage AC / DC	Max. Use Voltage* AC / DC	Rubber Molded Products Label	Glove Label	Rubber Dipped Sleeve Label
00 Beige	2,500 / 10,000	500 / 750			
0 Red	5,000 / 20,000	1,000 / 1,500			
1 White	10,000 / 40,000	7,500 / 11,250			
2 Yellow	20,000 / 50,000	17,000 / 25,500			
3 Green	30,000 / 60,000	26,500 / 39,750			

Voltage measurement at 4160V



Medium Voltage indicators



Changes



- Barricades cannot be placed closer than the limited approach boundary.
- Where the arc flash boundary is greater than the limited approach boundary, barricades cannot be placed closer than the arc flash boundary. [130.7(E)(2)]

Changes

Cutting and Drilling

- A new section is added requiring the employer to perform a risk assessment before cutting or drilling into equipment, floors, walls, or structural elements where a likelihood of contacting energized electrical lines or parts exists. [130.10]

Changes

Maintenance and Documentation

- Equipment owner or the owner's designated representative is responsible for
 - maintenance of the electrical equipment and
 - documentation. [205.3]

Changes

Tools,
Blankets

And

Gloves

- New maintenance requirements for test instruments and associated test leads utilized in the verification of the absence or presence of voltages were added.
- The maintenance program for test instruments must include functional verification as described in 110.4(A)(5).
[250.4]

ANSI/AIHA Z10

Risk
Assessment
procedure
100.1(G)

- Order of Controls to be used
- Eliminate
- Substitution
- Engineering controls
- Awareness
- Administrative Controls
- PPE

Electrical Safety Audits

Art 110.1 (I)

- Safety Program audit every 3 yrs.
- Field work audit every 1 year
- All Audits shall be documented
- Training Verification 1/year

Safety Related Maintenance

Art 205

- Only Qualified Persons
- Single-Line Diagram
- General maintenance in accordance with manufacture's instruction or industry consensus
 - Manufactures' IB
 - NETA
 - NFPA 70B
- Maintenance Shall BE Documented

Risk Assessment Definition

- Identifies all hazards
- Estimates the potential severity of injury
- Estimates the likelihood of occurrence of injury
- Determines the protective measures required

	Severity of the injury (consequences)				
Likelihood of occurrence in period	Slight	Minor	Medium	Critical	Catastrophic
Unlikely	1	2	3	4	5
Seldom	2	4	6	8	10
Occasional	3	6	9	12	15
Likely	4	8	12	16	20
Definite	5	10	15	20	25

Risk Assessment

- 1. The hazard always exists unless it can be engineered out of the design.
- 2. Risk increases in proportion to one's exposure to the hazard. The risk is zero if one is not exposed to the hazard.
- 3. The level of PPE = the degree of risk.

Safety Training

Art 110..2

- Train all exposed employees
 - Specific hazard of electricity
 - Safe work practices
 - Procedure for the task
 - Emergency response for shock annually
- Training will be
 - Classroom
 - OJT
- Employer will verify training current annually
- Employer will document all training require in NFPA 70E

WORK INVOLVING ELECTRICAL HAZARDS

Electrical Safe Work Condition (ESWC)

- Energized Conductor shall be put in an electrically safe work condition if:
 - Employee in the limited approach boundary
 - Employee interacts with equipment with and increased likelihood of injury from arc flash

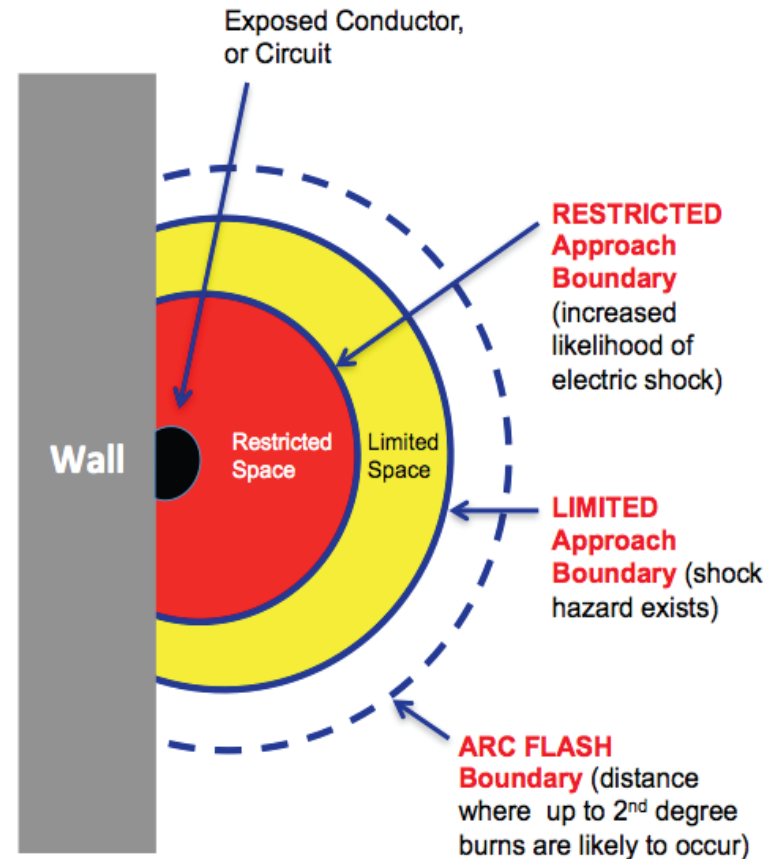

2015 Arc Flash Boundaries

Exception to ESWC

- When disconnecting means is properly
 - installed and
 - maintained and
 - is operated to achieve ESWC or
 - to return to service

IFF the risk assessment is performed and does not identify Unacceptable risk.

Example

- Main lugs only PDP or LDP fed from a services disconnect in a separate enclosure close nipped to the panel
- Only one source of power confirmed
- Risk assessment should indicate acceptable
- IN OSHA letter if the main is in the same enclosure and not barriered in any way the panel-board can not be put in a ESWC by opening the main breaker

Energized Work

1. Permitted if the EMPLOYER can demonstrate that De-energizing introduces more hazard. (Hazard could be non-electrical)
2. If EMPLOYER can demonstrate that the task is infeasible if the circuit de-energized such as voltage measure
3. Less Than 50V if it is determined to not increase the exposure to electrical burn or explosion

Energized Work (cont.)

- Normal Operation IFF:
 - Properly installed
 - Properly maintained
 - All doors closed and secured
 - All covers are in place
 - There is no evidence of impending failure

Example of increased hazard

- Interrupting life support equipment
- Deactivation of emergency alarm
- Shutdown of purge systems
- Shut downs effect on the plant

Energized Work Permit Shall Be Used

- When work performed in the restricted approach boundary
- When employee interacts with equipment where conductors not exposed but an increased likelihood of injury from exposure to arc flash exists

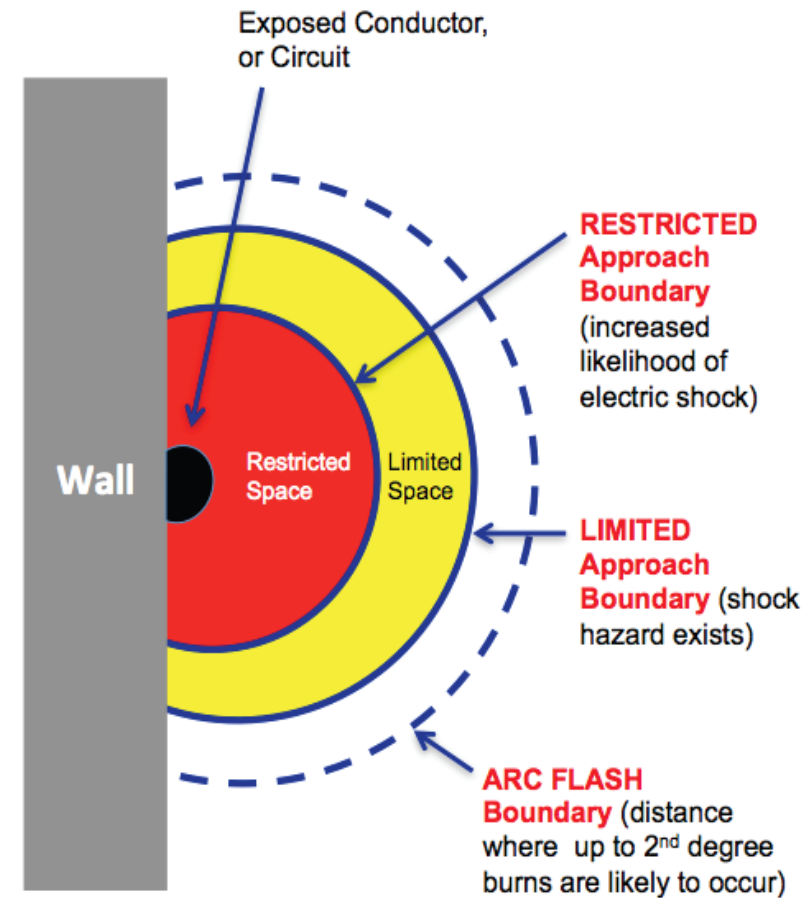

2015 Arc Flash Boundaries

Energized Work Permit shall include:

- Description of the circuit and equipment to be worked
- Justification for why work being done energized
- Description of safe work practices
- Result of Shock Risk assessment (130.4 (A))
 - Voltage exposure
 - Limited approach boundary (130.4 (B))
 - Restricted approach boundary (130.4 (B))
 - List of Personnel and other protective equipment

Energized Work Permit shall include:

- Results of the arc flash assessment
 - Available incident energy at working distance or arc flash PPE category
 - Necessary PPE to protect against the hazard
 - Arc flash boundary
- Means employed to restrict the access of unqualified persons to the work area
- Evidence of completion of the job briefing including a discussion of the job-specific hazards
- Energized work approval (authorizing or responsible management, safety officer or owners signature.

Exemptions to work permit

- Not required if a qualified person is provided with appropriate safe work practices and PPE for
 - Testing, troubleshooting and voltage measuring
 - Thermography and visual inspection if the restricted approach boundary is not crossed
 - Assess to and egress from an area with energized equipment if no work performed and restricted approach boundary not crossed
 - General housekeeping an not-electrical task of the restricted approach boundary not crossed

Working while Exposed to Electrical Hazards

- Safety related work practices shall safeguard from injury
- Shall be consistent with the associated risk
- Be determined before any person is exposed to hazard using shock risk assessment and arc flash assessment
- Only qualified persons shall be permitted to work on equipment not in ESWC

SHOCK RISK ASSESSMENT

Art 130.4

SHOCK RISK ASSESSMENT

- Voltage Exposure
- Boundary requirements
- PPE requirements



AC Voltage Approach Boundaries for Energized Conductors

(1)	(2)	(3)	(4)
Nominal System Voltage Range, Phase to Phase ^a	Limited Approach Boundary ^b		Restricted Approach Boundary ^b ; Includes Inadvertent Movement Adder
	Exposed Movable Conductor ^c	Exposed Fixed Circuit Part	
<50 V	Not specified	Not specified	Not specified
50 V–150 V ^d	3.0 m (10 ft 0 in.)	1.0 m (3 ft 6 in.)	Avoid contact
151 V–750 V	3.0 m (10 ft 0 in.)	1.0 m (3 ft 6 in.)	0.3 m (1 ft 0 in.)
751 V–15 kV	3.0 m (10 ft 0 in.)	1.5 m (5 ft 0 in.)	0.7 m (2 ft 2 in.)
15.1 kV–36 kV	3.0 m (10 ft 0 in.)	1.8 m (6 ft 0 in.)	0.8 m (2 ft 7 in.)

Approach Boundaries

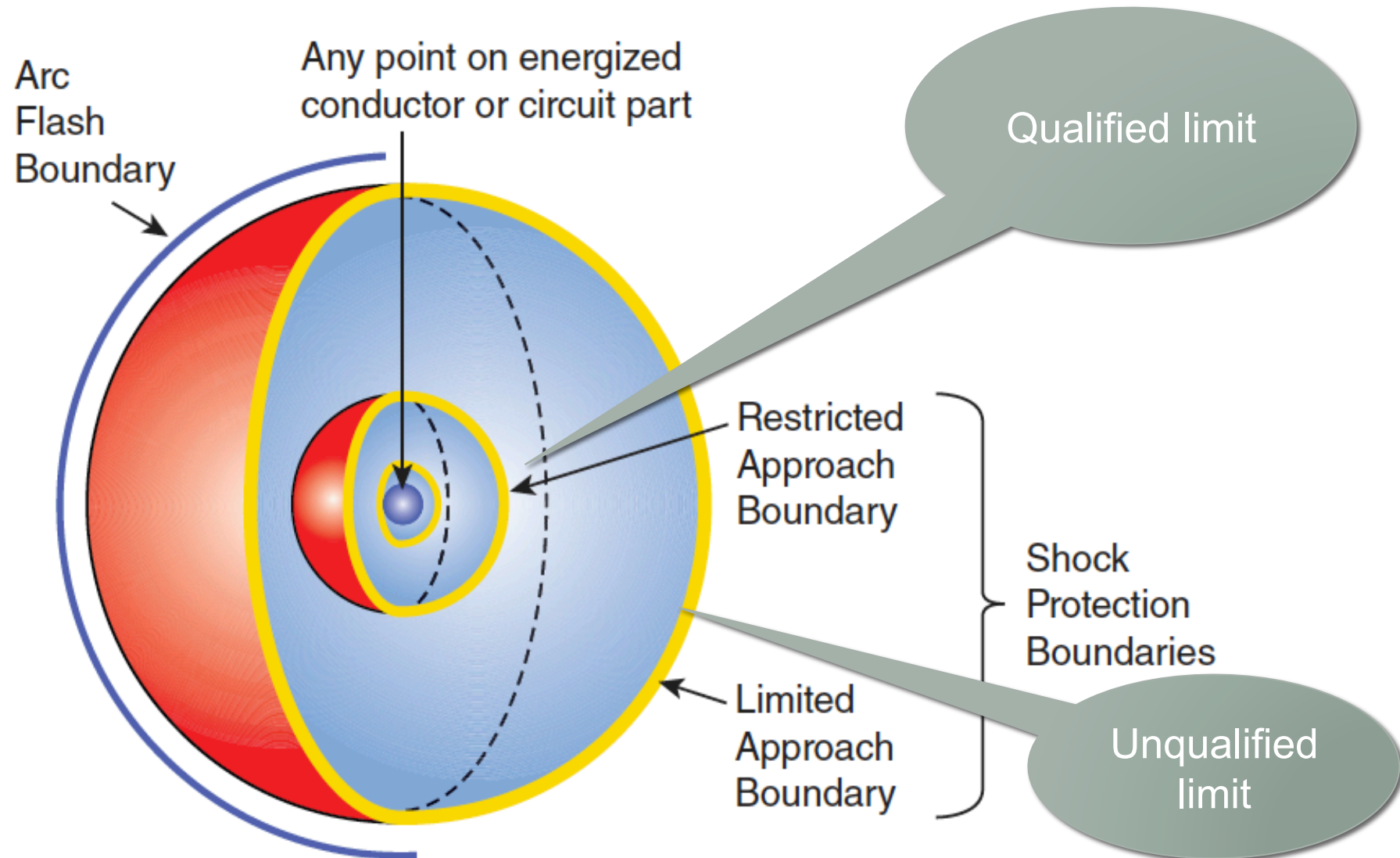

QUALIFIED PERSON



Qualified Person

- Demonstrated skills and knowledge of the equipment
 - Construction
 - Operation
 - Installation
- Received documented safety training
 - Identify
 - Avoidance

Qualified Person

- How to distinguish energized part
- Determine nominal voltage
- Approach distance tables
- Understand the hierarchy of controls, e.g. elimination, substitution, engineering controls, awareness, administrative controls, and PPE (lastly)

Qualified Person

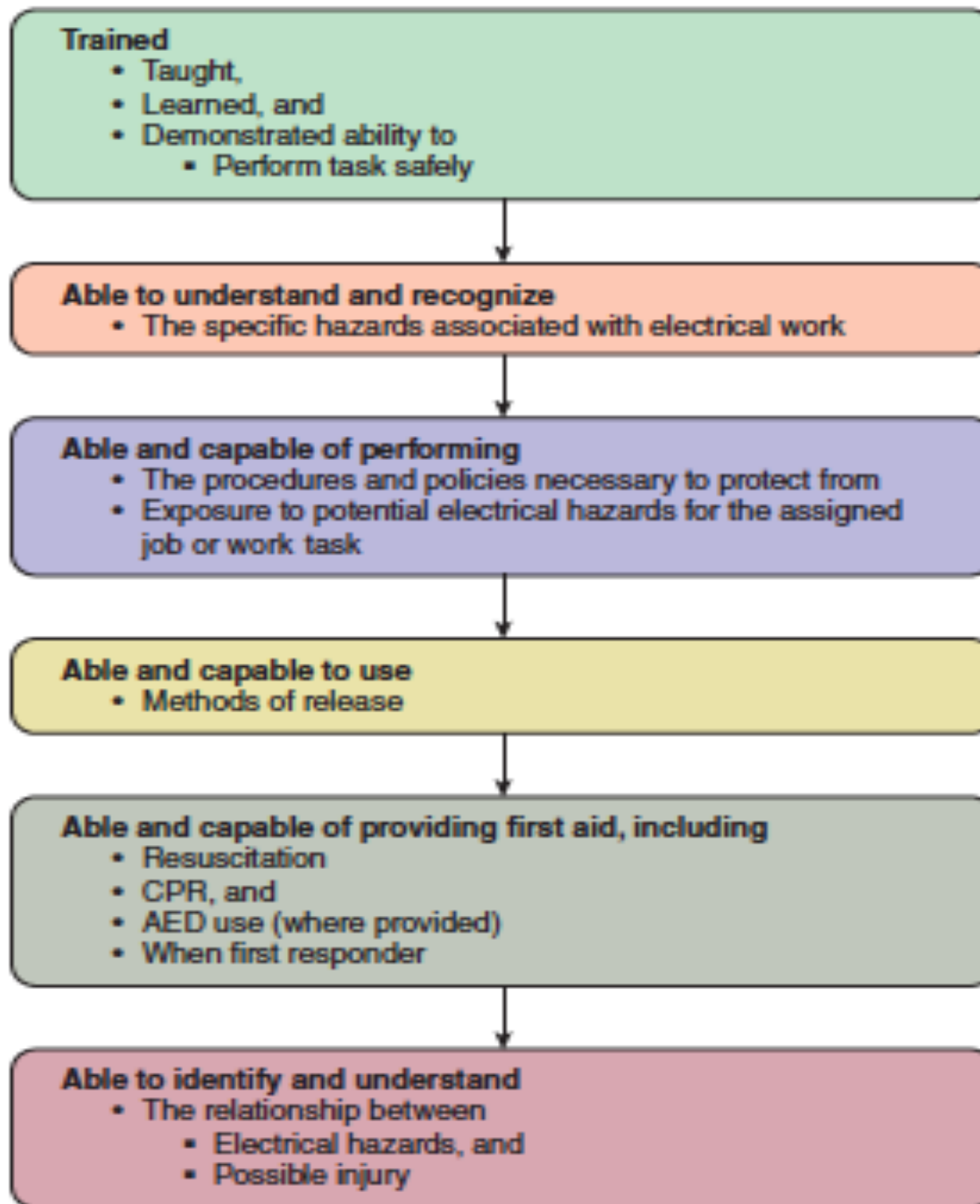

Qualified Person

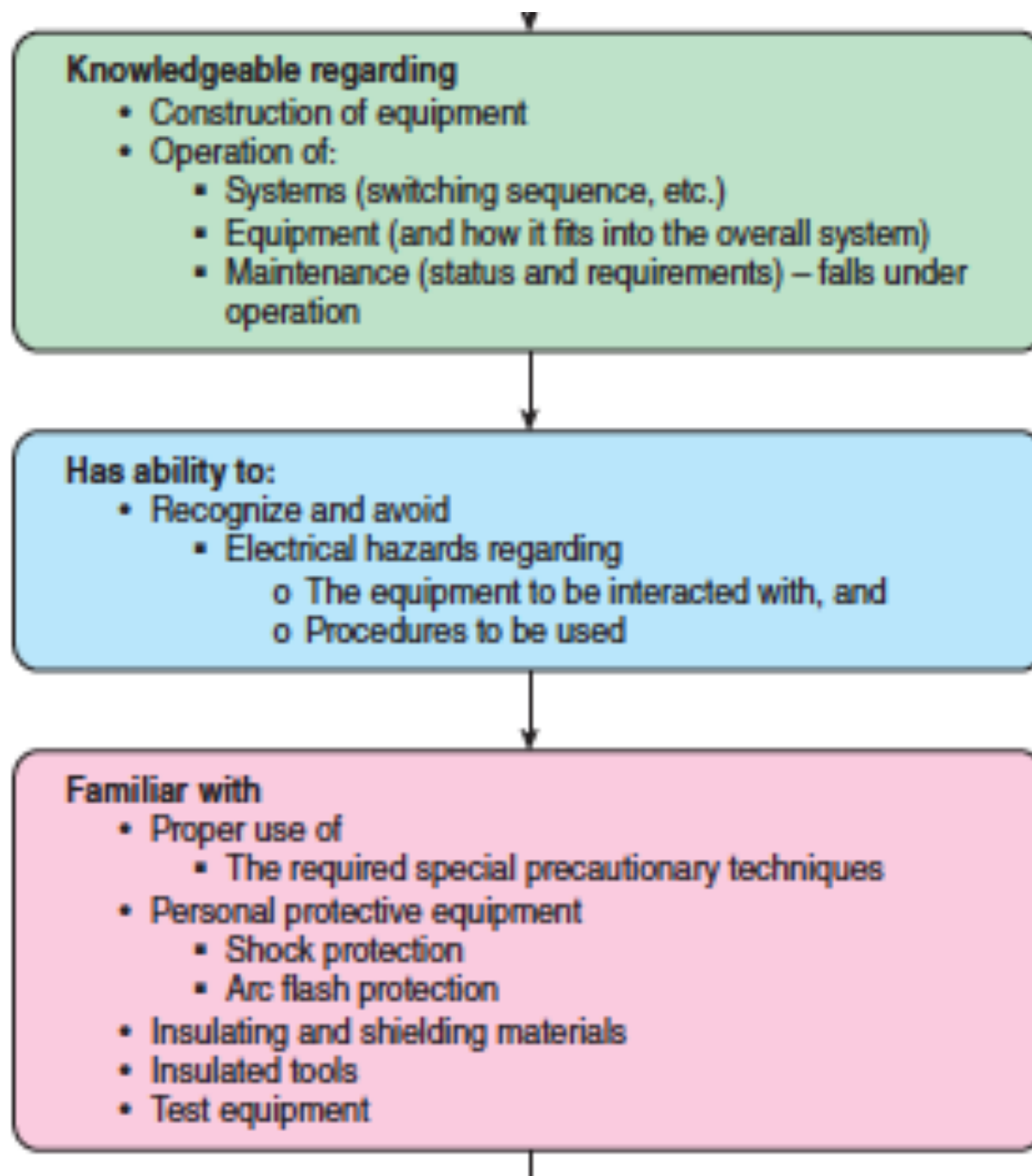

Is permitted to work

- Operating at 50 volts or more
- Within the limited approach boundary of
- Energized conductors and circuit parts (this is what system and equipment is made of)
- At a minimum
 - Has capability (knowledge and techniques)
 - Necessary to distinguish
 - Exposed energized electrical conductors and circuit parts
 - From other parts of electrical equipment (those that are not suitably guarded, isolated or insulated). See definition of exposed (as applied to energized electrical conductors and circuit parts) in Article 100
 - Has capability (knowledge and techniques)
 - Necessary to determine
 - Nominal system voltage of
 - Exposed energized electrical conductors and circuit parts
 - Knows and understands
 - The shock approach boundaries, and
 - How to determine
 - The limits of approach applicable
 - Before approaching exposed energized conductors or circuit parts
 - ac approach limits given in Table 130.4(D)(a)
 - dc approach limits given in Table 130.4(D)(b)
 - Understands
 - The decision making process, and
 - Is able to effectively utilize it to determine
 - The degree and extent of
 - The hazards present (particularly electrical hazards), and
 - The personal protective equipment (PPE) required
 - When acting as the person in charge (LOTO)
 - Is capable of accomplishing the job planning necessary to
 - Perform task safely
 - Including the required procedures (SOPs) and
 - Necessary sequence of work
 - Identifying the hazards and severity
 - Determining required personnel
 - Including first responders
 - Obtain and have on hand
 - Required first aid kit including
 - Emergency supplies determine necessary, and
 - Automatic external defibrillator, if determined necessary
 - Determine required PPE
 - Shock protection, as necessary
 - Arc flash protection, as necessary
 - Determine required test equipment
 - Voltage measuring instruments
 - Multi-meter, etc.
 - Determine additional equipment, components, parts, and tools required

ARC FLASH RISK ASSESSMENT

Art 130.5

Arc Flash Risk Assessment

- An arc flash risk assessment shall be performed with the results
- Does an arc flash hazard exists
- Related work practices
- Arc flash Boundary
- PPE for use in Boundary
- Be updated for changes
- Be review once every 5 yrs.
- Consider overcurrent protective device opening and clearing time and condition of maintenance

Breaker clearing

Example: clearing time of this breaker if fed from a 750kW standby gen or if fed from a 2000KVA xfmr.

Breaker Condition

Opening due to an IR scan showing c phase 20 degree hotter than a or b for a 50% FLA

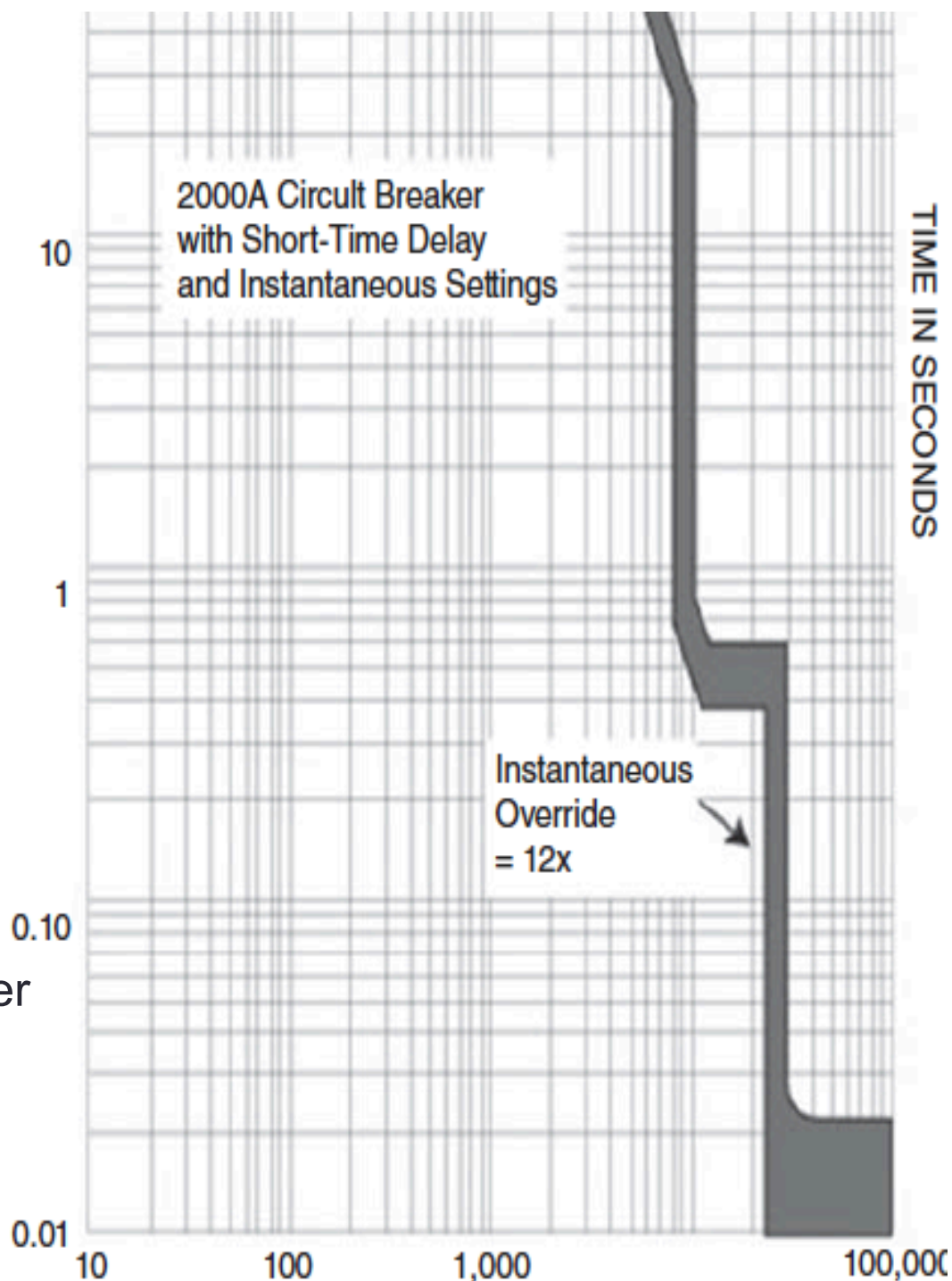

Estimating Clearing Time

- Use TCC curves and
- Estimate short circuit current and then use 38% of the value to determine total clearing time. (we call this the BS method)
- For medium voltage use 90 to 95% of the short circuit current and then use 85% of this value
- The ASTM std for Arc Rated clothing is spelled out to separate it from FR clothing

Art 130.5

Arc Flash Risk Assessment

- Must be documented
- Arc flash boundary = 1.2 cal/cm² (5 J/cm²)
- One of two methods but not both shall be used on the same piece of equipment
 - **Analysis** i.e. Calculation Annex D and Annex H Table H.3(b) Category or **Table method** 130.7
- Owner is responsible for documentation, installation and maint. of field-marked labels

PPE METHOD OR TABLE METHOD

Arc Flash PPE METHOD (table method)

Step 1	Table 130.7(C)(15)(A)(a)	IS PPE REQUIRED
Step 2	Table 130.7(C)(15)(A) (b)	PPE Category & Arc Flash Boundary
Step 3	Table 130.7(C)(16)	PPE Suit Out (what do you have to Wear)

Note there is also the simplified 8cal/40cal table method see Annex H table H.2

Table 130.7(C)(15)(A)(a) Arc Flash Hazard Identification for (ac) (dc) Systems

<i>Task</i>	<i>Equipment Condition*</i>	<i>Arc Flash PPE Required</i>
Reading a panel meter while operating a meter switch	Any	No
Normal operation of a circuit breaker (CB), switch, contactor, or starter	All of the following: The equipment is properly installed The equipment is properly maintained All equipment doors are closed and secured All equipment covers are in place and secured There is no evidence of impending failure	No
	One or more of the following: The equipment is not properly installed The equipment is not properly maintained Equipment doors are open or not secured Equipment covers are off or not secured There is evidence of impending failure	Yes
For ac systems: Work on energized electrical conductors and circuit parts, including voltage testing	Any	Yes

Table 130.7(C)(15)(A)(a) Arc Flash Hazard Identification for (ac) (dc) Systems

For dc systems: Work on energized electrical conductors and circuit parts of series-connected battery cells, including voltage testing	Any	Yes
Voltage testing on individual battery cells or individual multi-cell units	<p>All of the following:</p> <ul style="list-style-type: none"> The equipment is properly installed The equipment is properly maintained Covers for all other equipment are in place and secured There is no evidence of impending failure 	No
	<p>One or more of the following:</p> <ul style="list-style-type: none"> The equipment is not properly installed The equipment is not properly maintained Equipment doors are open or not secured Equipment covers are off or not secured There is evidence of impending failure 	Yes

Table 130.7(C)(15)(A)(a) Arc Flash Hazard Identification for (ac) (dc) Systems

<i>Task</i>	<i>Equipment Condition*</i>	<i>Arc Flash PPE Required</i>
Removal or installation of CBs or switches	Any	Yes
Removal or installation of covers for equipment such as wireways, junction boxes, and cable trays that does not expose bare energized electrical conductors and circuit parts	All of the following: The equipment is properly installed The equipment is properly maintained There is no evidence of impending failure	No
	Any of the following: The equipment is not properly installed The equipment is not properly maintained There is evidence of impending failure	Yes

Table 130.7(C)(15)(A)(a) Arc Flash Hazard Identification for (ac) (dc) Systems

Opening hinged door(s) or cover(s) (to expose bare energized electrical conductors and circuit parts)	Any	Yes
Perform infrared thermography and other noncontact inspections outside the restricted approach boundary. This activity does not include opening of doors or covers.	Any	No
Application of temporary protective grounding equipment after voltage test	Any	Yes
Work on control circuits with exposed energized electrical conductors and circuit parts, 120 volts or below without any other exposed energized equipment over 120 V including opening of hinged covers to gain access	Any	No
Work on control circuits with exposed energized electrical conductors and circuit parts, greater than 120 V	Any	Yes

Table 130.7(C)(15)(A)(a) Arc Flash Hazard Identification for (ac) (dc) Systems

Insertion or removal of individual starter buckets from motor control center (MCC)	Any	Yes
Insertion or removal (racking) of CBs or starters from cubicles, doors open or closed	Any	Yes
Insertion or removal of plug-in devices into or from busways	Any	Yes
Insulated cable examination with no manipulation of cable	Any	No
Insulated cable examination with manipulation of cable	Any	Yes

Table 130.7(C)(15)(A)(a) Arc Flash Hazard Identification for (ac) (dc)

Systems

Arc-resistant switchgear Type 1 or 2 (for clearing times of <0.5 sec with a prospective fault current not to exceed the arc-resistant rating of the equipment) and metal enclosed interrupter switchgear, fused or unfused of arc resistant type construction, tested in accordance with IEEE C37.20.7:

- Insertion or removal (racking) of CBs from cubicles
- Insertion or removal (racking) of ground and test device
- Insertion or removal (racking) of voltage transformers on or off the bus

All of the following:

The equipment is properly installed

The equipment is properly maintained

All equipment doors are closed and secured

All equipment covers are in place and secured

There is no evidence of impending failure

No

One or more of the following:

The equipment is not properly installed

The equipment is not properly maintained

Equipment doors are open or not secured

Equipment covers are off or not secured

There is evidence of impending failure

Yes

Table 130.7(C)(15)(A)(a) Arc Flash Hazard Identification for (ac) (dc) Systems

Opening voltage transformer or control power transformer compartments	Any	Yes
Outdoor disconnect switch operation (hookstick operated) at 1 kV through 15 kV	Any	Yes
Outdoor disconnect switch operation (gang-operated, from grade) at 1 kV through 15 kV	Any	Yes

Table 130.7(C)(15)(A)(b) Arc Flash Hazard PPE Category

<i>Equipment</i>	<i>Arc Flash PPE Category</i>	<i>Arc-Flash Boundary</i>
<p>Panelboards or other equipment rated 240 V and below</p> <p>Parameters: Maximum of 25 kA short-circuit current available; maximum of 0.03 sec (2 cycles) fault clearing time; working distance 455 mm (18 in.)</p>	1	485 mm (19 in.)
<p>Panelboards or other equipment rated >240 V and up to 600 V</p> <p>Parameters: Maximum of 25 kA short-circuit current available; maximum of 0.03 sec (2 cycles) fault clearing time; working distance 455 mm (18 in.)</p>	2	900 mm (3 ft)

Table 130.7(C)(15)(A)(b) Arc Flash Hazard PPE Category

<p>600-V class motor control centers (MCCs)</p> <p>Parameters: Maximum of 65 kA short-circuit current available; maximum of 0.03 sec (2 cycles) fault clearing time; working distance 455 mm (18 in.)</p>	2	1.5 m (5 ft)
<p>600-V class motor control centers (MCCs)</p> <p>Parameters: Maximum of 42 kA short-circuit current available; maximum of 0.33 sec (20 cycles) fault clearing time; working distance 455 mm (18 in.)</p>	4	4.3 m (14 ft)
<p>600-V class switchgear (with power circuit breakers or fused switches) and 600 V class switchboards</p> <p>Parameters: Maximum of 35 kA short-circuit current available; maximum of up to 0.5 sec (30 cycles) fault clearing time; working distance 455 mm (18 in.)</p>	4	6 m (20 ft)
<p>Other 600-V class (277 V through 600 V, nominal) equipment</p> <p>Parameters: Maximum of 65 kA short circuit current available; maximum of 0.03 sec (2 cycles) fault clearing time; working distance 455 mm (18 in.)</p>	2	1.5 m (5 ft)

Table 130.7(C)(15)(A)(b) Arc Flash Hazard PPE Category

<p>NEMA E2 (fused contactor) motor starters, 2.3 kV through 7.2 kV</p> <p>Parameters: Maximum of 35 kA short-circuit current available; maximum of up to 0.24 sec (15 cycles) fault clearing time; working distance 910 mm (36 in.)</p>	4	12 m (40 ft)
<p>Metal-clad switchgear, 1 kV through 15 kV</p> <p>Parameters: Maximum of 35 kA short-circuit current available; maximum of up to 0.24 sec (15 cycles) fault clearing time; working distance 910 mm (36 in.)</p>	4	12 m (40 ft)
<p>Arc-resistant switchgear Type 1 or 2 [for clearing times of < 0.5 sec (30 cycles) with a perspective fault current not to exceed the arc-resistant rating of the equipment], and metal-enclosed interrupter switchgear, fused or unfused of arc-resistant-type construction, tested in accordance with IEEE C37.20.7, 1 kV through 15 kV</p>	N/A (doors closed)	N/A (doors closed)

Table 130.7(C)(15)(A)(b) Arc Flash Hazard PPE Category

Parameters: Maximum of 35 kA short-circuit current available; maximum of up to 0.24 sec (15 cycles) fault clearing time; working distance 910 mm (36 in.)	4 (doors open)	12 m (40 ft)
Other equipment 1 kV through 15 kV Parameters: Maximum of 35 kA short-circuit current available; maximum of up to 0.24 sec (15 cycles) fault clearing time; working distance 910 mm (36 in.)	4	12 m (40 ft)

Note: For equipment rated 600 volts and below, and protected by upstream current-limiting fuses or current-limiting circuit breakers sized at 200 amperes or less, the arc flash PPE category can be reduced by one number but not below arc flash PPE category 1.

Table 130.7(C)(16) PPE Equipment

PPE Category

PPE

1 **Arc-Rated Clothing, Minimum Arc Rating of 4 cal/cm² (see Note 1)**

Arc-rated long-sleeve shirt and pants or arc-rated coverall

Arc-rated face shield (see Note 2) or arc flash suit hood

Arc-rated jacket, parka, rainwear, or hard hat liner (AN)

Protective Equipment

Hard hat

Safety glasses or safety goggles (SR)

Hearing protection (ear canal inserts)

Heavy duty leather gloves (see Note 3)

Leather footwear (AN)

2 **Arc-Rated Clothing, Minimum Arc Rating of 8 cal/cm² (see Note 1)**

Arc-rated long-sleeve shirt and pants or arc-rated coverall

Arc-rated flash suit hood or arc-rated face shield (see Note 2) and arc-rated balaclava

Arc-rated jacket, parka, rainwear, or hard hat liner (AN)

Protective Equipment

Hard hat

Safety glasses or safety goggles (SR)

Hearing protection (ear canal inserts)

Heavy duty leather gloves (see Note 3)

Leather footwear

Table 130.7(C)(16) PPE Equipment

3	<p>Arc-Rated Clothing Selected so That the System Arc Rating Meets the Required Minimum Arc Rating of 25 cal/cm² (see Note 1)</p> <p>Arc-rated long-sleeve shirt (AR) Arc-rated pants (AR) Arc-rated coverall (AR) Arc-rated arc flash suit jacket (AR) Arc-rated arc flash suit pants (AR) Arc-rated arc flash suit hood Arc-rated gloves (see Note 3) Arc-rated jacket, parka, rainwear, or hard hat liner (AN)</p> <p>Protective Equipment</p> <p>Hard hat Safety glasses or safety goggles (SR) Hearing protection (ear canal inserts) Leather footwear</p>
---	---

Table 130.7(C)(16) PPE Equipment

PPE Category

PPE

4	<p data-bbox="331 539 2068 592">Arc-Rated Clothing Selected so That the System Arc Rating Meets the Required Minimum Arc Rating of 40 cal/cm²</p> <p data-bbox="1108 609 1285 662">(see Note 1)</p> <p data-bbox="968 678 1430 732">Arc-rated long-sleeve shirt (AR)</p> <p data-bbox="1045 743 1352 797">Arc-rated pants (AR)</p> <p data-bbox="1026 813 1371 867">Arc-rated coverall (AR)</p> <p data-bbox="947 878 1451 932">Arc-rated arc flash suit jacket (AR)</p> <p data-bbox="951 943 1446 997">Arc-rated arc flash suit pants (AR)</p> <p data-bbox="995 1008 1402 1062">Arc-rated arc flash suit hood</p> <p data-bbox="989 1073 1409 1127">Arc-rated gloves (see Note 3)</p> <p data-bbox="802 1138 1598 1192">Arc-rated jacket, parka, rainwear, or hard hat liner (AN)</p> <p data-bbox="1031 1203 1367 1256">Protective Equipment</p> <p data-bbox="1129 1268 1268 1321">Hard hat</p> <p data-bbox="934 1333 1461 1386">Safety glasses or safety goggles (SR)</p> <p data-bbox="932 1398 1463 1451">Hearing protection (ear canal inserts)</p> <p data-bbox="1073 1463 1325 1516">Leather footwear</p>
---	--

CALCULATION METHOD

INCIDENT ENERGY AT WORKING
DISTANCE AND ARC FLASH BOUNDARY

5J/cm² or 1.2cal/cm²

Table D.1 Limitation of Calculation Methods

<i>Section</i>	<i>Source</i>	<i>Limitations/Parameters</i>
D.2	Lee, "The Other Electrical Hazard: Electrical Arc Flash Burns"	Calculates incident energy and arc flash boundary for arc in open air; conservative over 600 V and becomes more conservative as voltage increases
D.3	Doughty, et al., "Predicting Incident Energy to Better Manage the Electrical Arc Hazard on 600 V Power Distribution Systems"	Calculates incident energy for three-phase arc on systems rated 600 V and below; applies to short-circuit currents between 16 kA and 50 kA
D.4	IEEE 1584, <i>Guide for Performing Arc Flash Calculations</i>	Calculates incident energy and arc flash boundary for: 208 V to 15 kV; three-phase; 50 Hz to 60 Hz; 700 A to 106,000 A short-circuit current; and 13 mm to 152 mm conductor gaps
D.5	Doan, "Arc Flash Calculations for Exposure to DC Systems"	Calculates incident energy for dc systems rated up to 1000 V dc

LEE calc 600Vac Approximation

Distance for 2nd degree burns of < 80C

$$D_c = \left[2.65 \times MVA_{bf} \times t \right]^{\frac{1}{2}} \quad [\text{D.2.1(d)}]$$

$$D_c = \left[53 \times MVA \times t \right]^{\frac{1}{2}} \quad [\text{D.2.1(e)}]$$

where:

D_c = distance in feet of person from arc source for a just curable burn (that is, skin temperature remains less than 80°C).

MVA_{bf} = bolted fault MVA at point involved.

MVA = MVA rating of transformer. For transformers with MVA ratings below 0.75 MVA , multiply the transformer MVA rating by 1.25.

t = time of arc exposure in seconds.

Lee's Incident Energy Calc for greater than 600V

$$E = \frac{793 \times F \times V \times t_A}{D^2}$$

where:

E = incident energy, cal/cm²

F = bolted fault short-circuit current, kA

V = system phase-to-phase voltage, kV

t_A = arc duration, sec

D = distance from the arc source, in.

Doughty/ Neal Equation

- Calculated incident energy given working distances
- Introduced the 38% of bolted fault value as the min limit for LV
- Recognized that highest incident energy could occur at lowest level due to extended clearing time.

Doughty and Neal Equation

$$E_{MA} = 5271 D_A^{-1.9593} t_A \left[\begin{array}{l} 0.0016 F^2 \\ - 0.0076 F \\ + 0.8938 \end{array} \right]$$

where:

- E_{MA} = maximum open arc incident energy, cal/cm²
- D_A = distance from arc electrodes, in. (for distances 18 in. and greater)
- t_A = arc duration, sec
- F = short-circuit current, kA (for the range of 16 kA to 50 kA)

IEEE 1584 Calcs Limitation

- 208 VAC to 15kV 3 phase
- 50 and 60hZ
- 700A to 106kA available fault current
- 13mm(1/2 in) to 152mm (6in) conductor gap

Guide for a 1584.1 - 2015 study

- Collect System and Installation Data
- Determine modes of operation
- Calculate Bolted Fault Current
- Determine approximate Arc Fault Current
- Find TCC, total clearing time and duration of arcs
- Document system voltages and equipment class
- Select working (distance source to person chest)
- Determine incident energy
- Determine arc flash boundary

Run calc at bolt faults and at .85 and use higher incident energy

$$\lg E_n = k_1 + k_2 + 1.081 \lg l_a + 0.0011G$$

$$E = 4.184C_f E_n \left(\frac{t}{0.2} \right) \left(\frac{610^x}{Dx} \right)$$

E = incident energy, J/cm²

C_f = calculation factor

= 1.0 for voltages above 1 kV.

= 1.5 for voltages at or below 1 kV.

E_n = incident energy normalized.

t = arcing time, sec.

x = distance exponent from Table D.4.2.

D = distance, mm, from the arc to the person (working distance).

Distance exponent x in equation

Table D.4.2 Factors for Equipment and Voltage Classes

<i>System Voltage (kV)</i>	<i>Type of Equipment</i>	<i>Typical Conductor Gap (mm)</i>	<i>Distance Exponent Factor x</i>
0.208–1	Open air	10–40	2.000
	Switchgear	32	1.473
	MCCs and panels	25	1.641
	Cables	13	2.000
>1–5	Open air	102	2.000
	Switchgear	13–102	0.973
	Cables	13	2.000
>5–15	Open air	13–153	2.000
	Switchgear	153	0.973
	Cables	13	2.000

Typical working distance D for eq

<i>Classes of Equipment</i>	<i>Typical Working Distance*</i> (mm)
15-kV switchgear	910
5-kV switchgear	910
Low-voltage switchgear	610
Low-voltage MCCs and panelboards	455
Cable	455

Over 15kV and 3 phase

$$E = 2.142 \times 10^6 VI_{bf} \left(\frac{t}{D^2} \right)$$

E = incident energy, J/cm²

V = system voltage, kV

I_{bf} = available three-phase bolted fault current

t = arcing time, sec

D = distance (mm) from the arc to the person (working distance)

Assume: Bolted fault = arcing fault

Use engineering judgment on 2sec rule

OVER 15kV and 3 phase

$$D_B = \sqrt{2.142 \times 10^6 VI_{bf} \left(\frac{t}{E_B} \right)}$$

Assume E_B of 5Joules /cm²

Other important parts of Annex D

- Arc flash boundary calc
- Differing incident energy calc for various fuse arrangements
- Differing incident energy for MCCB and
- Direct Current calcs based on arcing current of 50% the bolted fault current

Calc and Table Method Separation



WARNING

Arc Flash and Shock Hazard

Nominal System Voltage _____

Incident Energy (cal/cm²) _____

Arc Flash Boundary _____

Working Distance _____

Restricted Approach _____

OR

PPE Hazard Category _____

Limited Approach _____

Arc Rating of Clothing _____

Arc-rated PPE:

<input type="checkbox"/> Face shield	<input type="checkbox"/> Coverall
<input type="checkbox"/> Long-sleeve shirt	<input type="checkbox"/> Balaclava
<input type="checkbox"/> Flash suit jacket	<input type="checkbox"/> Gloves
<input type="checkbox"/> Flash suit pants	<input type="checkbox"/> Jacket
<input type="checkbox"/> Flash suit hood	<input type="checkbox"/> Parka
<input type="checkbox"/> Pants	<input type="checkbox"/> Rainwear

Additional PPE:

<input type="checkbox"/> Hard hat	<input type="checkbox"/> Leather footwear
<input type="checkbox"/> Safety goggles	<input type="checkbox"/>
<input type="checkbox"/> Safety glasses	<input type="checkbox"/>
<input type="checkbox"/> Hearing protection	<input type="checkbox"/>
<input type="checkbox"/> Heavy duty leather gloves	<input type="checkbox"/>

Equipment ID:



130.7(D)

Other Protective Equipment

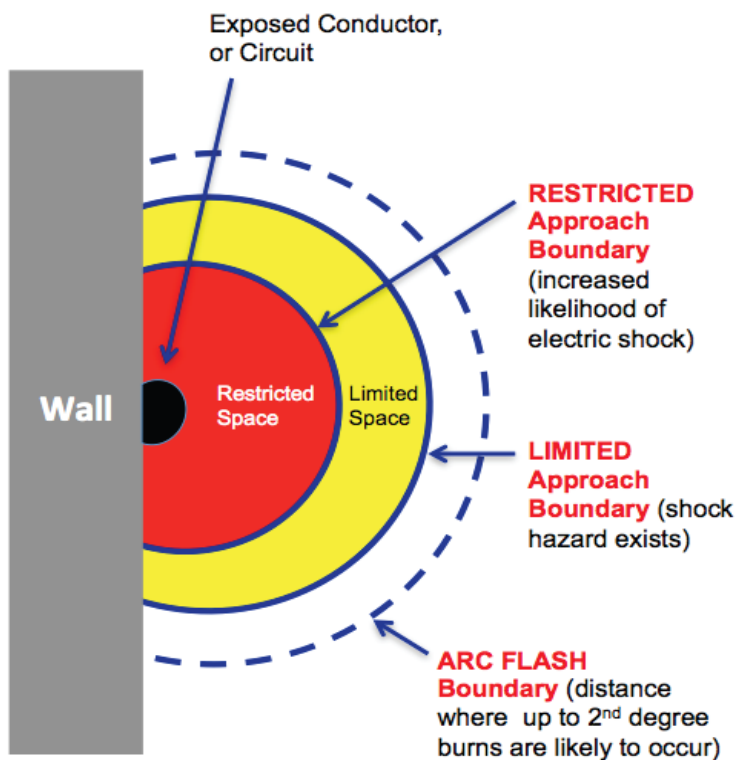

2015 Arc Flash Boundaries

- Insulated tools are required inside the restricted approach boundary
- Rated for the voltage
- Inspected prior to use
- Insulate ladder only

Hazardous (Classified) Locations

Art 235

- No breaks in conduit system
- All enclosure are secure
- All bonding is intact
- Marking are legible

Personal Safety and Protective Equipment

250.2 Tools

250.3

TPGE

250.4 &

110.4 Test
Instrument

- Tools
 - Inspection and Test once per year
- Temporary protective grounds
TPGE (ground cables, ground & test, and ground switch)
 - Inspect once per year
 - Tested prior to being returned for service
 - Stored in a clean environment
- Test Instruments
 - Visual before each use
 - Maintenance program

BATTERY SYSTEM

Battery Systems

- New section 320.3(A)(1) requires a risk assessment to work on a battery system
- Annex D for DC Arc Flash
- Scope lists applicable NFPA, IEEE and OSHA

Battery System

- Prior to any work must do a risk assessment
 - Thermal
 - Chemical
 - Electric Shock
 - Arc Flash
- Room Requirements
 - Only authorized personnel
 - Illumination
- No electrical conductive objects
- Instruments must be test once/yrs.

Battery Systems

- Avoid shock hazard
- Insulating parts using temporary insulation
- Determine cell line area boundaries

Battery System



Battery System

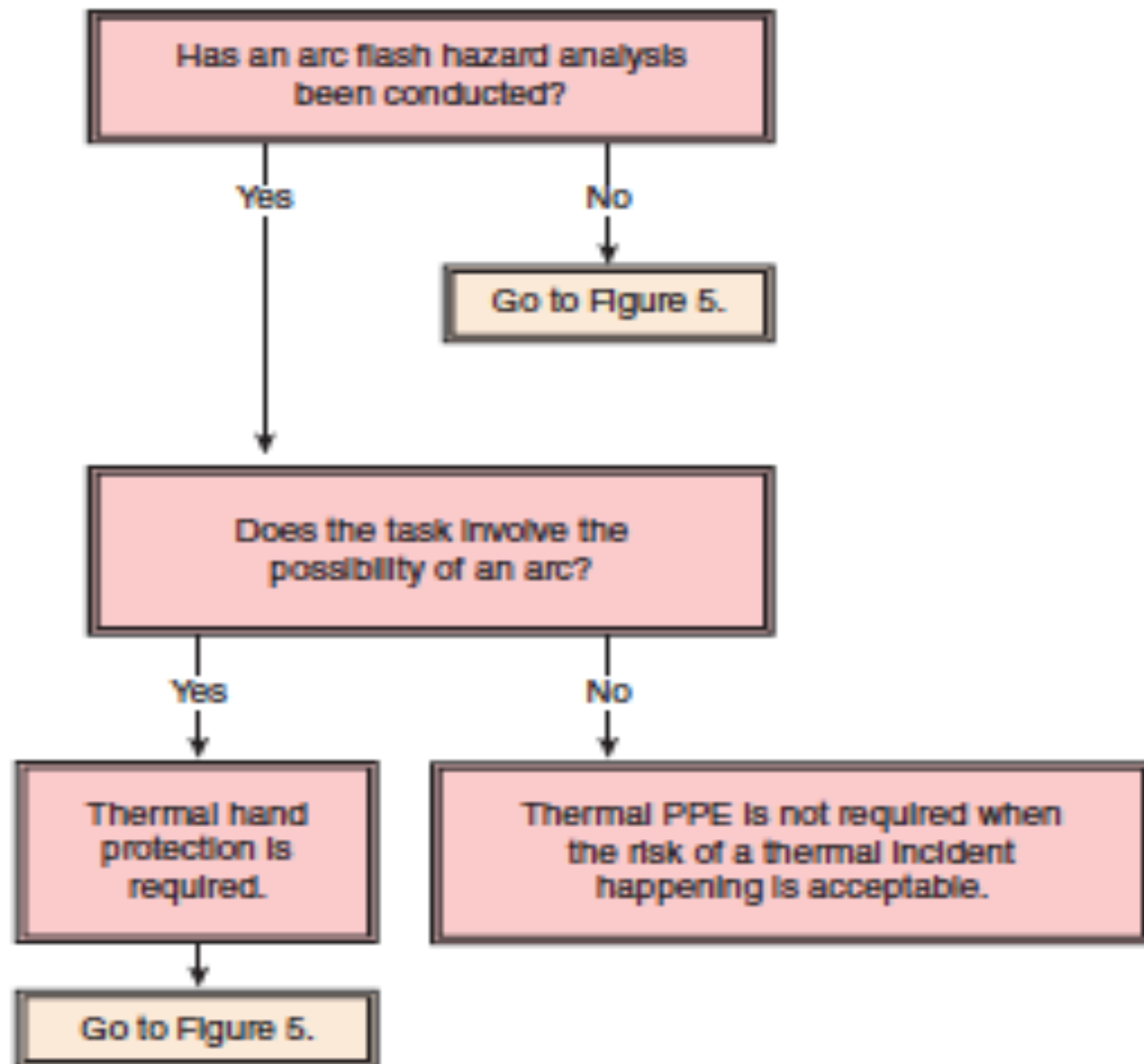

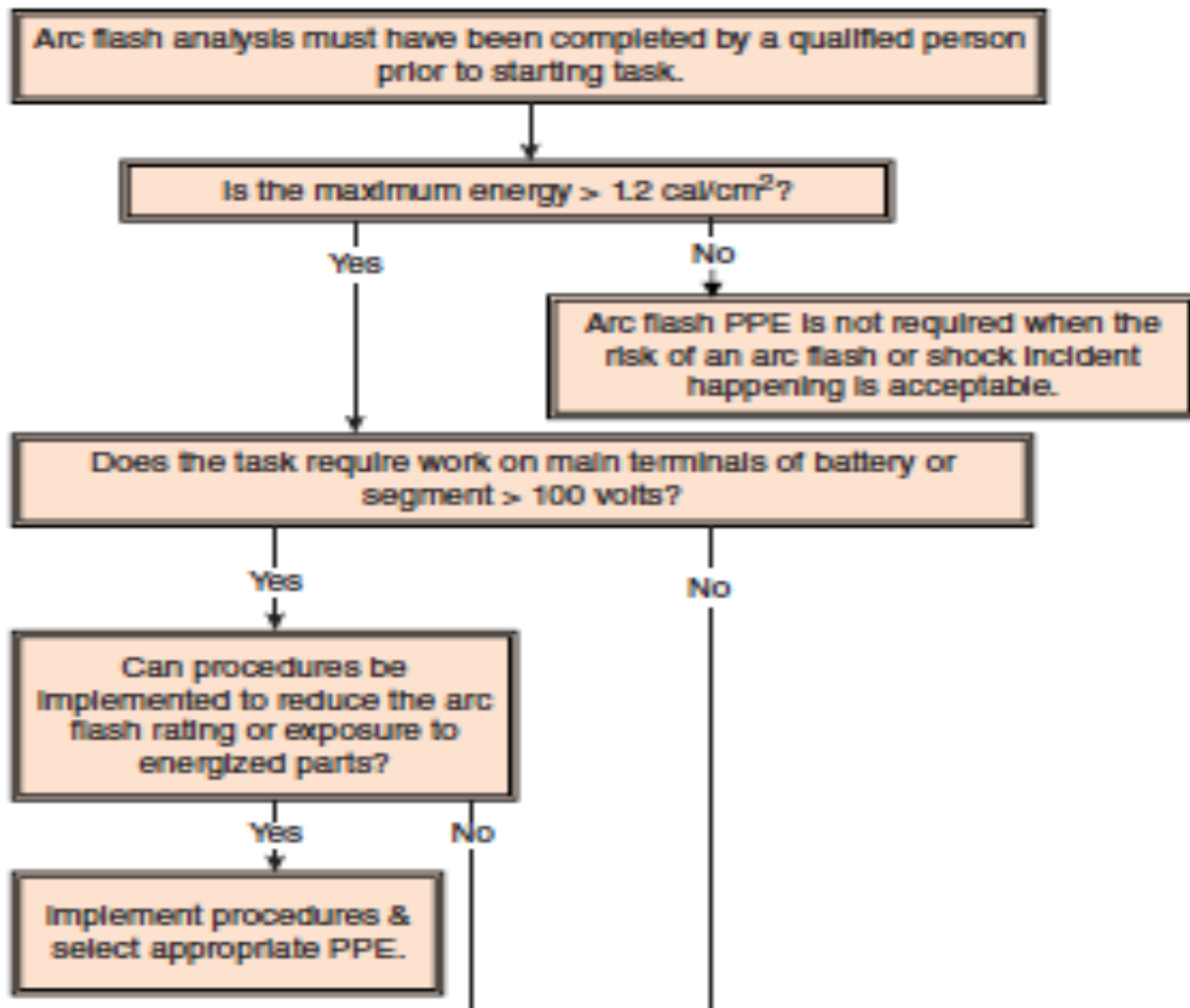

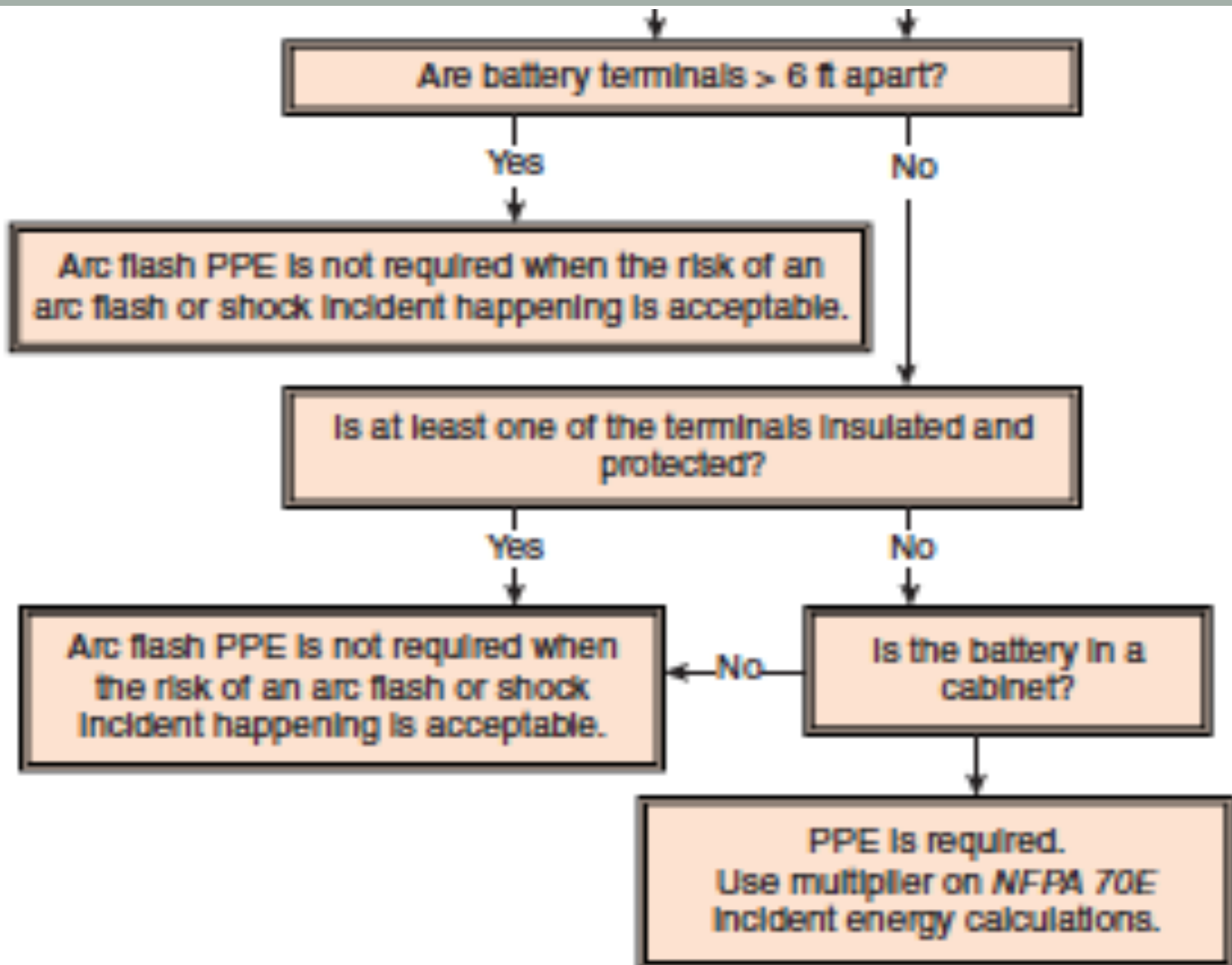

ANNEXS

ANNEXs

- A & B = referenced publications
- C = Limits of Approach
- D=Incident Energy Calculation
- E= Electrical Safety Boundary
- F=Risk Assessment Procedure

ANNEXs

- G = Sample Lock and Tag Out
- H = PPE Selection
- I = Job Briefing Checklist
- J = Energized Electrical Work Permit
- K = General Categories of Hazards
- L = Cell Line Zone (DC)

ANNEXs

- M = PPE Layering
- N = Working Near Overhead Lines
- O = Safety Related Design Requirements
- P = NFPA – OSHA relations
- K = General Categories of Hazards
- L = Cell Line Zone (DC)

Supplement

- List of NFPA 70 sections
- Preventive Maintenance Program
- Selection and inspection of insulated PPE (typical safety procedure)
- Case Study of Arc Flash Incident

SAFETY PROGRAM

Annex E – Electrical Safety Program

- Inspecting and Evaluating Electrical Equipment
- Maintaining the Electrical Equipment
- Planning every job and document first-time procedures
- De-energizing when possible
- Anticipating unexpected events
- Identifying the electrical hazards and reduce the risk
- Using the right tool
- Assessing peoples ability
- Auditing the principles

Annex E - Safety Program Controls

- Employer develops the program and trains the employees
- Procedures used to identify, eliminate and/or control risks
- Every electrical conductor is considered live until proved otherwise
- De-energize and make electrically safe
- Tasks are identified and categorized
- Take appropriate Precautions
- An approach is used to determine risk

Safety Program Procedures

- Purpose of task
- Qualification and # of people involved
- Assessment of risks
- Limits of approach
- Safe work practices used
- PPE required
- Insulating material and tools
- Special precautionary techniques
- Electrical Single Line Diagram
- Equipment Details
- Photos of unique features
- Reference data – IB's

RISK ASSESSMENT

ANNEX F

F Risk Assessment Procedure

- Determines protective measures to reduce likelihood of injury
- Risk assessment is a process of assigning a severity and a likelihood to each hazard associated with an at risk behavior
- Allows for ADEQUATE risk reduction = 8 Acceptable with moderate risk

Likelihood of occurrence in period	Severity of the injury (consequences)				
	Slight	Minor	Medium	Critical	Catastrophic
Unlikely	1	2	3	4	5
Seldom	2	4	6	8	10
Occasional	3	6	9	12	15
Likely	4	8	12	16	20
Definite	5	10	15	20	25

Risk Assessment Includes

- Identify and analyzing the hazards
- Identify task to be performed by their component parts
- Documenting hazards associated with each task
- Estimating the risk for each hazard
- Determine the appropriate measures to reduce the risk

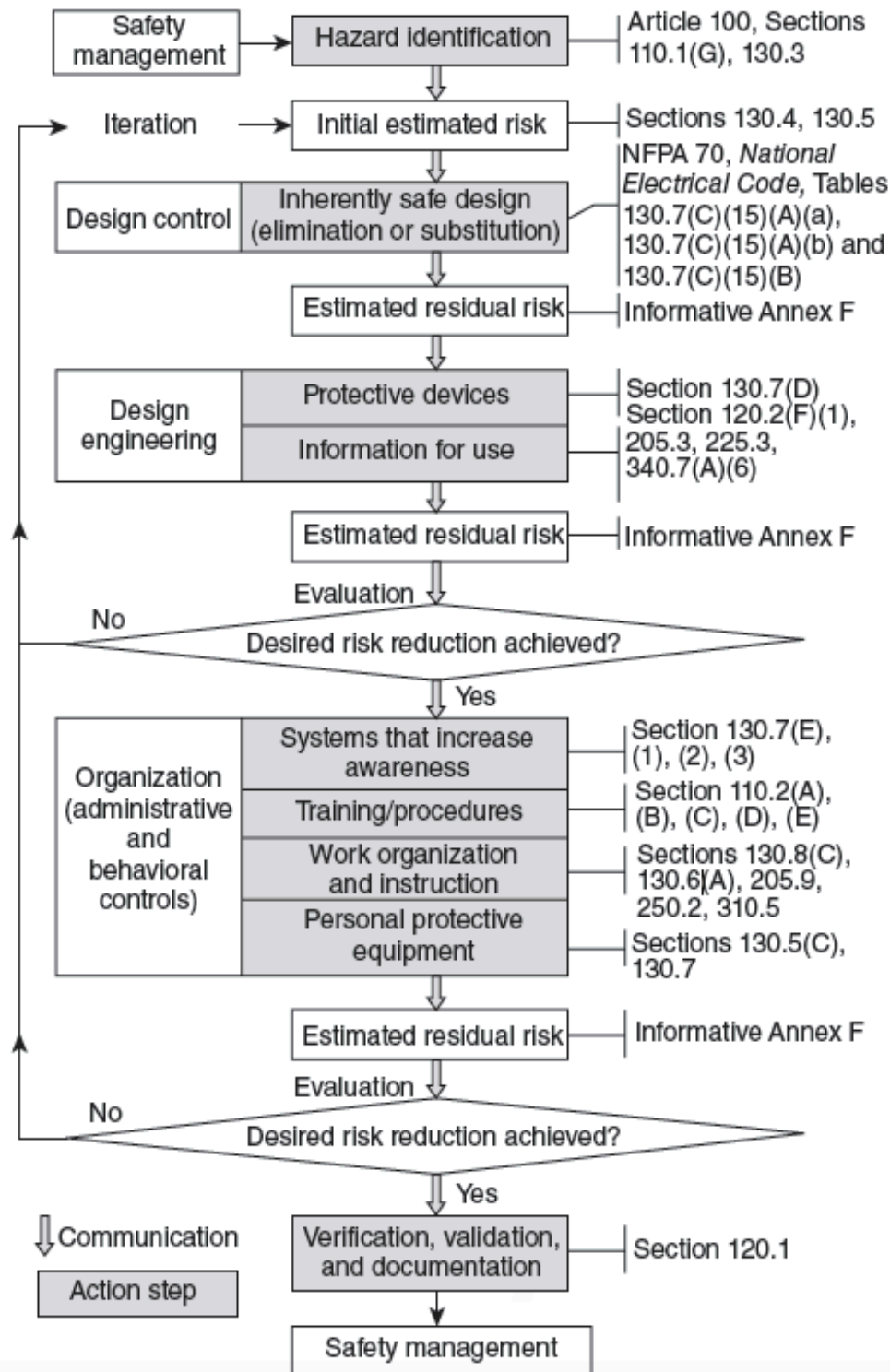

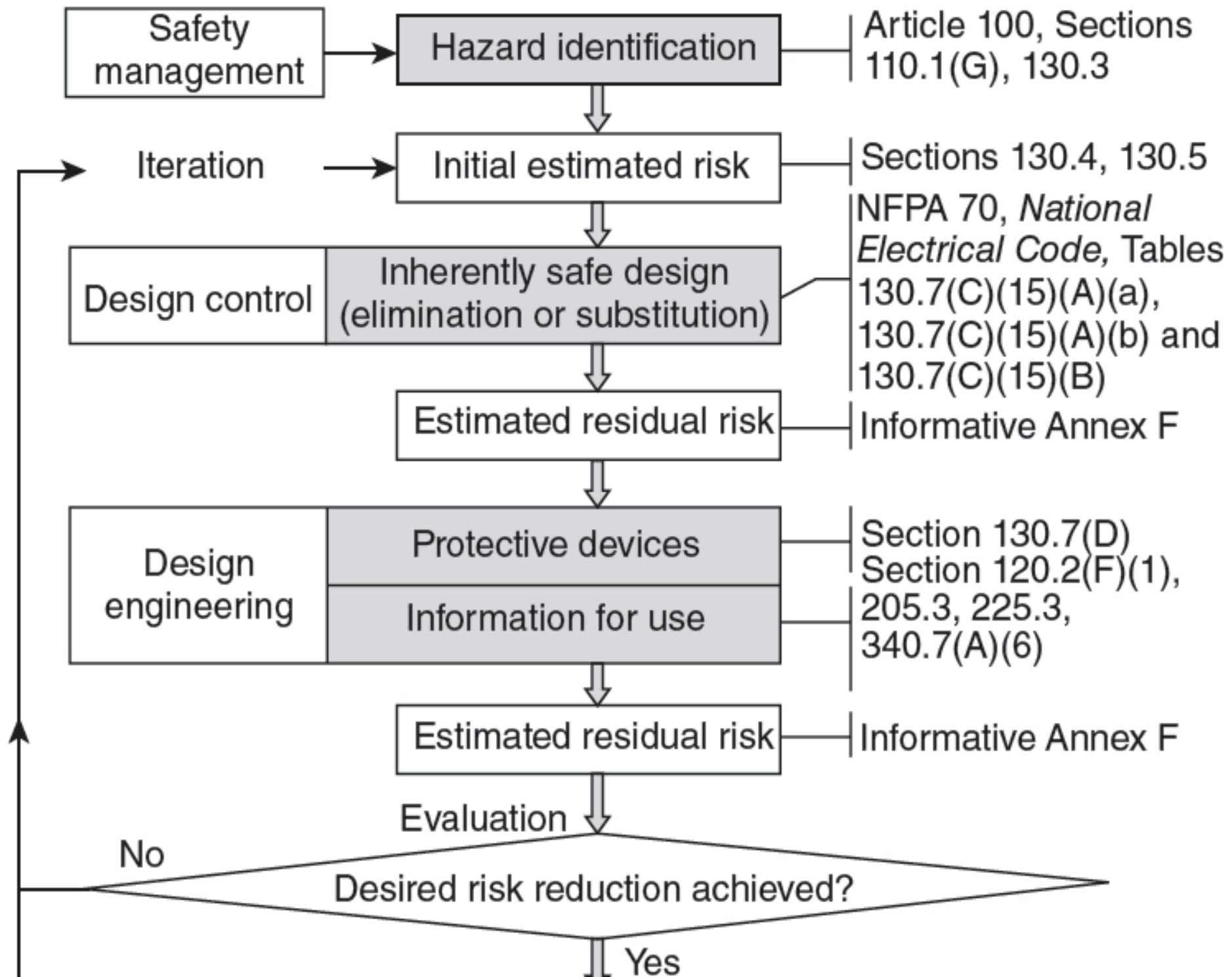

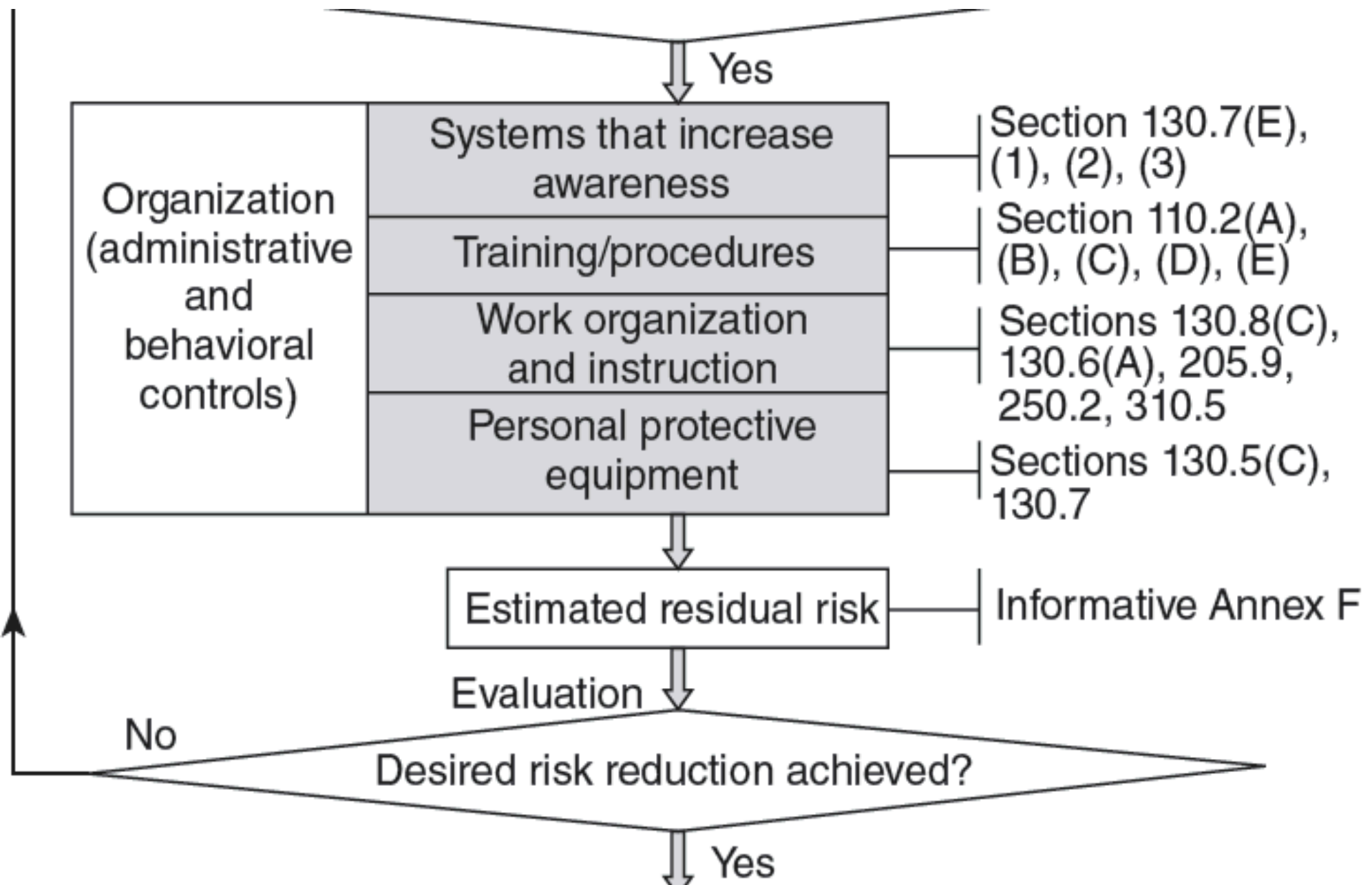

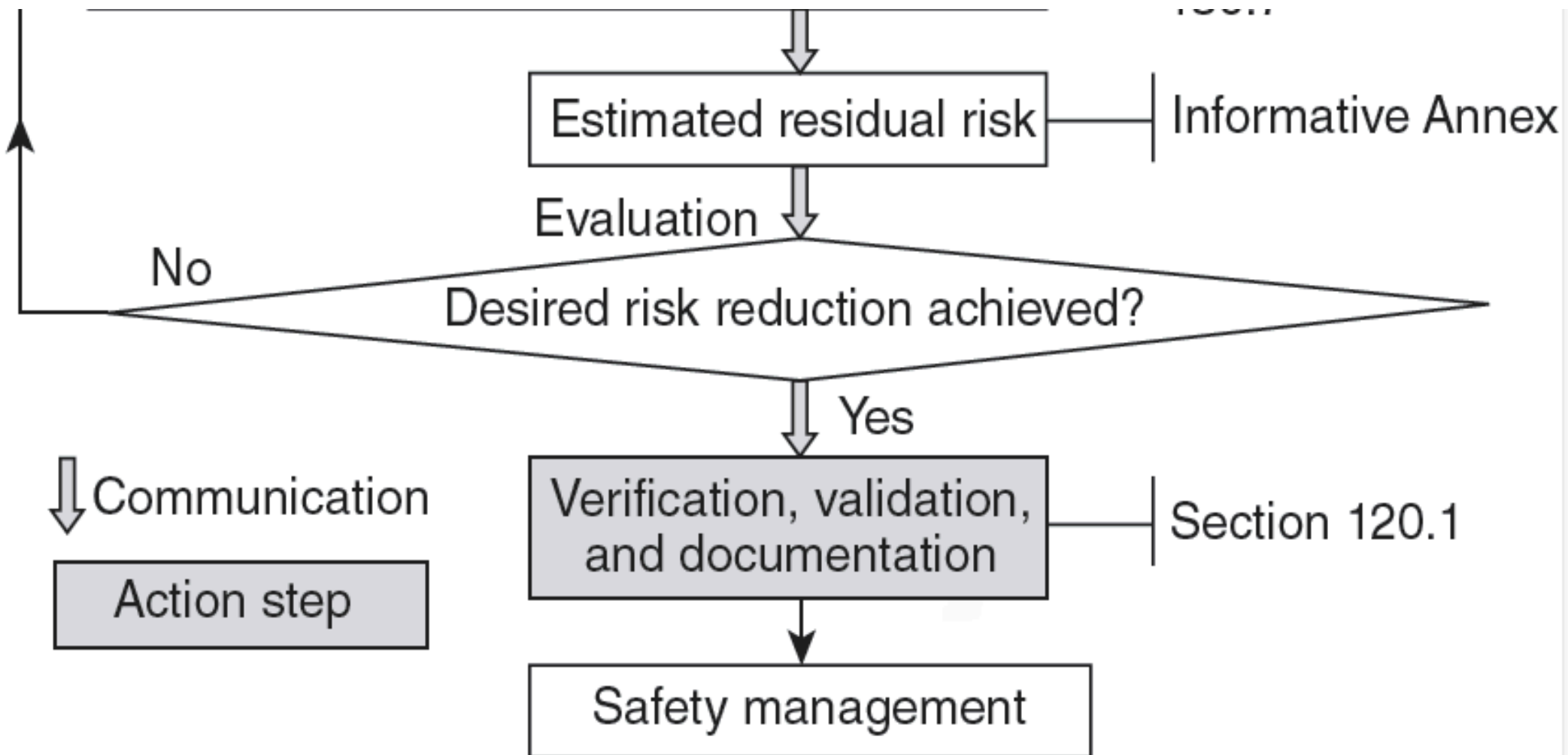

Annex F - Responsibility

- Designers and constructor and users have a responsibility for achieving tolerable risk

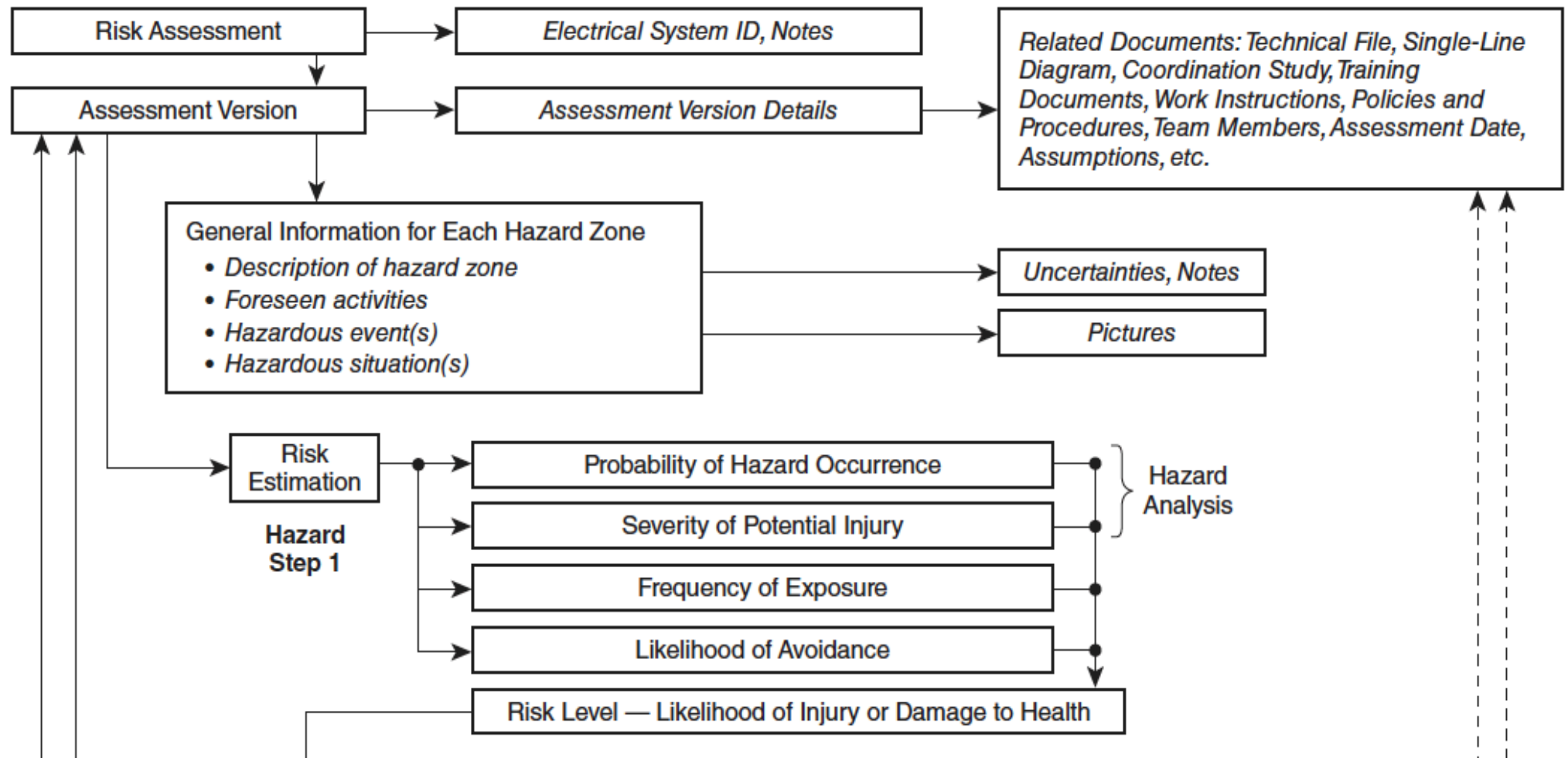

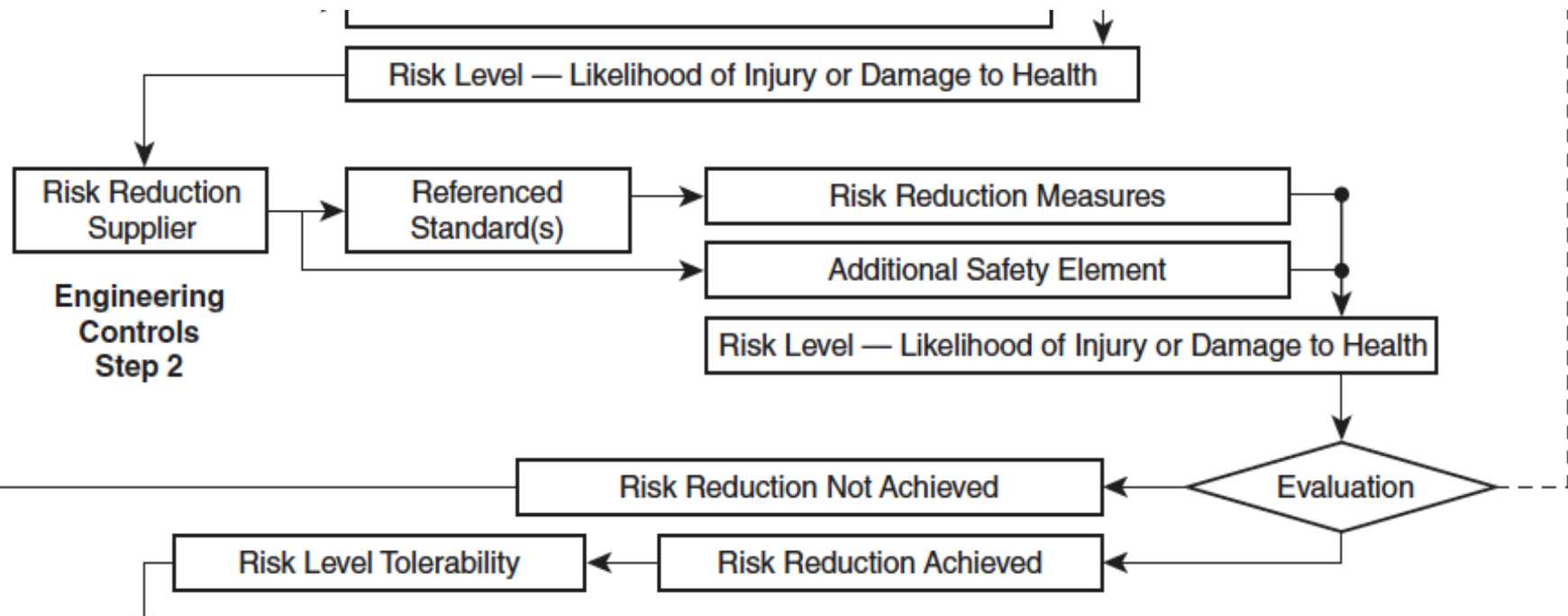

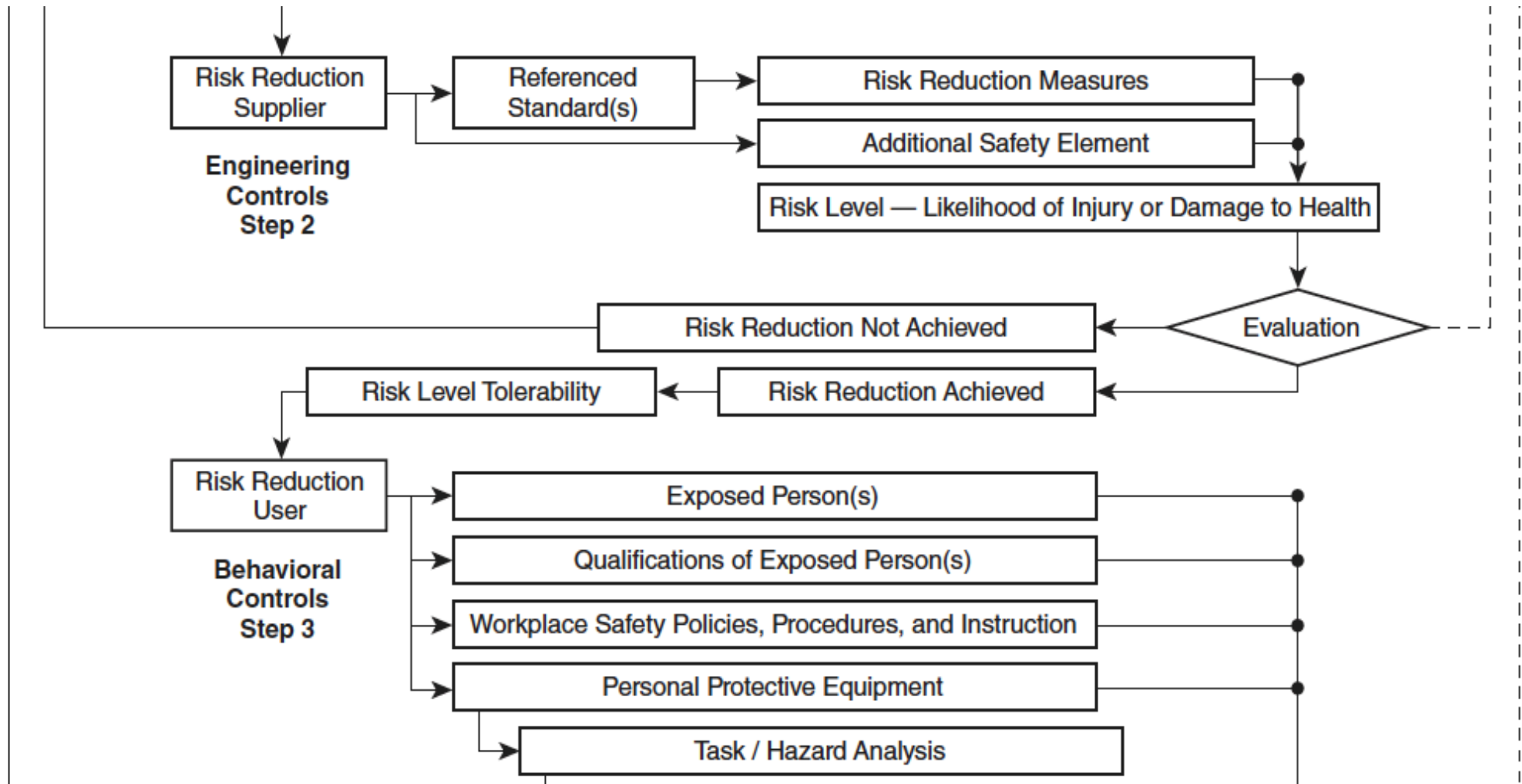

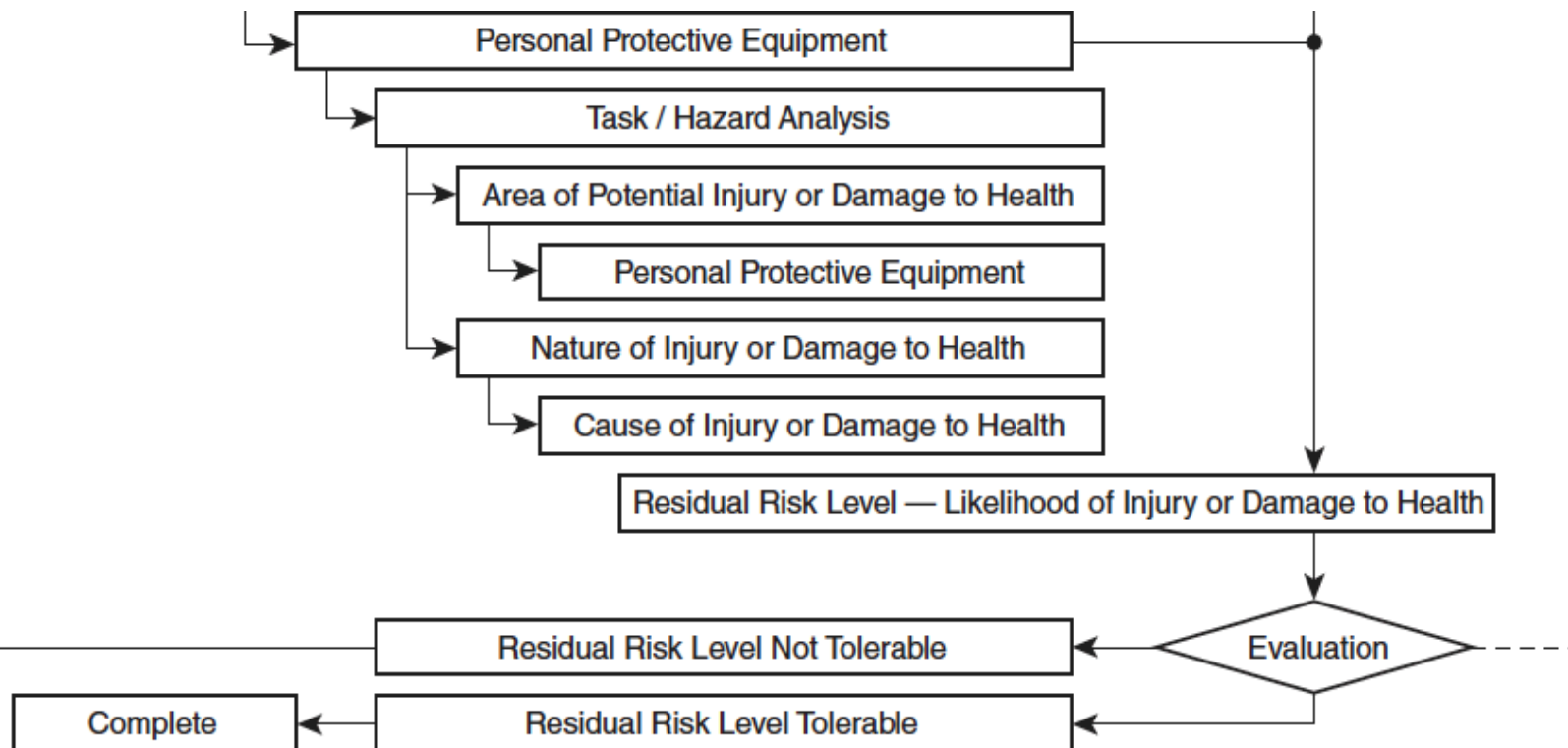

Initial Risk Estimation

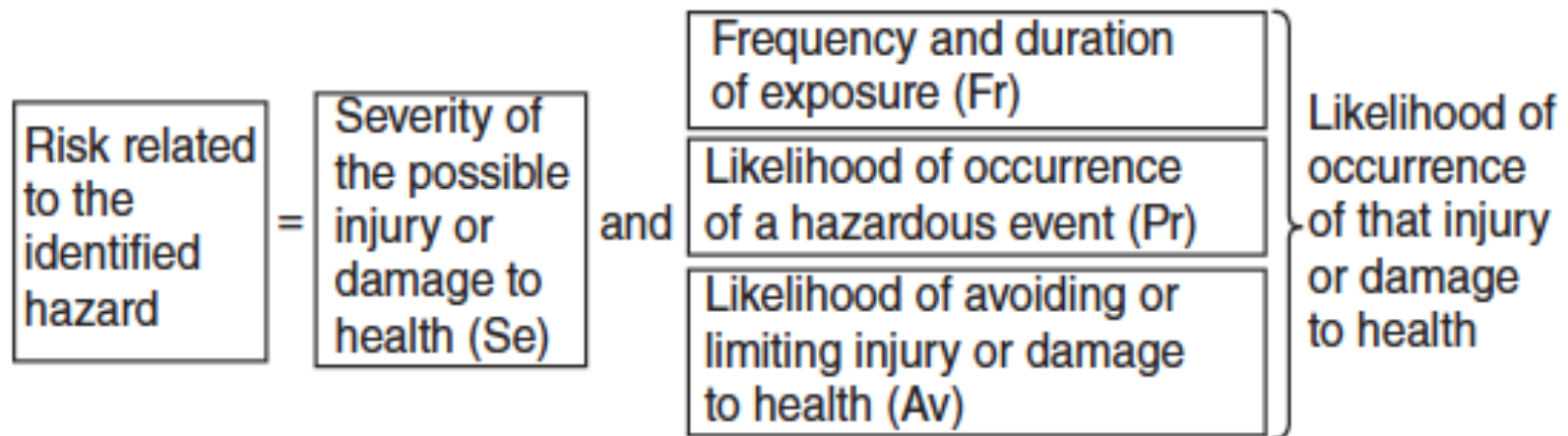

FIGURE F.2.1 *Elements of Risk.*

- Sum of $Se+FR+PR+Av = \text{Risk}$
- Or $Se(Fr+Pr+Av) = \text{Risk}$
- Or use the risk register

Se = Severity

TABLE F.2.3 *Severity of the Possible Injury or Damage to Health (Se) Classification*

<i>Severity of Injury or Damage to Health</i>	<i>Se Value</i>
Irreversible — trauma, death	8
Permanent — skeletal damage, blindness, hearing loss, third degree burns	6
Reversible — minor impact, hearing damage, second degree burns	3
Reversible — minor laceration, bruises, first degree burns	1

Fr = Frequency

TABLE F.2.4.1 Frequency and Duration of Exposure (Fr) Classification

<i>Frequency of Exposure</i>	<i>Fr Value (for Duration >10 min)</i>
≤ 1 per hour	5
> 1 per hour to ≤ 1 per day	5
> 1 per day to ≤ 1 every 2 weeks	4
> 1 every 2 weeks to ≤ 1 per year	3
> 1 per year	2

Pr = Likelihood

TABLE F.2.4.2 *Likelihood of a Hazardous Event (Pr) Classification*

<i>Likelihood of a Hazardous Event</i>	<i>Pr Value</i>
Very high	5
Likely	4
Possible	3
Rare	2
Negligible	1

Typical Pr questions

- At what point in its life is the equipment
- Has an IR scan been done under load
- When was the last time the upstream breaker was operated
- Is the breaker within its nameplate rating

Risk

Extreme (E)	RED	Intolerable Risk
High (H)	ORANGE	Unsupportable risk
Moderate (M)	YELLOW	Tolerable Risk
Low (L)	GREEN	Supportable Risk

Risk assessment matrix

	Severity of the injury (consequences)				
Likelihood of occurrence in period	Slight	Minor	Medium	Critical	Catastrophic
Unlikely	L	L	L	M	M
Seldom	L	L	M	M	H
Occasional	L	M	M	H	E
Likely	M	M	H	E	E
Definite	M	H	E	E	E

Risk assessment using numbers

	Severity of the injury (consequences)				
Likelihood of occurrence in period	Slight	Minor	Medium	Critical	Catastrophic
Unlikely	1	2	3	4	5
Seldom	2	4	6	8	10
Occasional	3	6	9	12	15
Likely	4	8	12	16	20
Definite	5	10	15	20	25

Protective Measures

- Once prior risk established evaluate risk reduction using controls
- Both technical and behavioural failures must be considered
- As a minimum all items in the risk assessment in red and orange must be reduced with controls to yellow and green
- If substitution and elimination can not control the risk a combination of less level controls may be needed

Design or Elimination or Substitution

- Eliminate the severity or likelihood
- Substitution effects severity and likelihood
- Engineering Controls by Design effects likelihood

Awareness

- Warning signs
 - POTENTIAL IMPACT on limiting likelihood
 - POTENTIAL IMPACT on exposure
 - No Impact on severity
- Personnel Training
 - Limit injury severity
 - May impact likelihood under limited conditions
- Access restrictions
 - Impact on exposure
 - No impact on severity
- Safe work Practices
 - Impact on Likelihood
 - No impact on severity



PPE

- Impact on severity
- Negative impact on likelihood of some events due to mobility and visibility



Shock OR ARC Blast causes

- Loose connections
- Loose object in enclosure
- Equipment, component, or part at the end of life
- Improperly grounded equipment
- Vermin in the equipment
- Defective component or part
- Moisture or other contaminant in the equipment
- Improper size or type of component
- Improperly maintained circuit breaker
- Alignment issues on with-drawable components

Auditing

- Each activity that has been assessed it may require an audit prior to work taking place.

Hazard (situation)	Risk Reduction Strategy	Confirmation (in place) Yes / No
Human factors (mistakes)	Training and instructions include details regarding hazardous situations that could arise.	
Human factors (willful disregard)	Policies and supervision are in place in order to ensure that instructions are followed.	
Unqualified person performing electrical work	Work permit system is in place to control personnel activities.	
Inappropriate overcurrent protection	Instructions include details regarding the selection or replacement of fuses and/or circuit breakers.	

Circuit Breaker Operation while Energized

- Assume operating a 1600A 480V molded case circuit breaker. One line says 35kA available.
- Per table 130.7(C)(15)(A)(b) at 18inches assume greater than 25cal/cm²
- The maint records show the breaker is operated twice a year when maint is done on the facility
- Se Severity from table F.2.3 is 6,
- Fr Frequency of exposure table F2.4.2 is 3
- Pr Frequency and duration from table F.2.3.1 is determined to be 1
- Av The likelihood of avoiding injury is determined to be 1 since it is 480VAC metal enclosed equipment
- Total Risk is 36 and as such requires some other control Typically a score of 10 is orange.
 - Since it is operated twice a year I would put a shunt trip or else investigate an arm extension. NFPA70E recommended PPE.

Annex H PPE selection for arc flash risk assessment

- Incident energy method
- Table method (PPE Category)
- Also offers a two category method

Table H.2 Simplified Two-Category, Arc-Rated Clothing System

<i>Clothing^a</i>	<i>Applicable Tasks</i>
<p data-bbox="310 574 873 634">Everyday Work Clothing</p> <p data-bbox="100 651 1083 862">Arc-rated long-sleeve shirt with arc-rated pants (minimum arc rating of 8)</p> <p data-bbox="569 883 625 927"><i>or</i></p> <p data-bbox="113 948 1068 1008">Arc-rated coveralls (minimum arc rating of 8)</p>	<p data-bbox="1173 574 2049 862">All arc flash PPE category 1 and arc flash PPE category 2 tasks listed in Table 130.7(C)(15)(A)(a), Table 130.7(C)(15)(A)(b), and Table 130.7(C)(15)(B)^b</p>
<p data-bbox="428 1062 753 1122">Arc Flash Suit</p> <p data-bbox="50 1138 1131 1414">A total clothing system consisting of arc-rated shirt and pants and/or arc-rated coveralls and/or arc flash coat and pants (clothing system minimum arc rating of 40)</p>	<p data-bbox="1178 1062 2039 1349">All arc flash PPE category 3 and arc flash PPE category 4 tasks listed in Table 130.7(C)(15)(A)(a), Table 130.7(C)(15)(A)(b), and Table 130.7(C)(15)(B)^b</p>

Table Method

TABLE H.3(b) Guidance on Selection of Arc-Rated Clothing and Other PPE for Use When Incident Energy Exposure Is Determined

Incident Energy Exposure	Protective Clothing and PPE
<p>$\leq 1.2 \text{ cal/cm}^2$ Protective clothing, nonmelting (in accordance with ASTM F 1506) or untreated natural fiber</p>	<p>Shirt (long sleeve) and pants (long) or coverall</p>
<p>Other PPE</p>	<p>Face shield for projectile protection (AN) Safety glasses or safety goggles (SR) Hearing protection Heavy-duty leather gloves or rubber insulating gloves with leather protectors (AN)</p>

Table Method

> 1.2 to 12 cal/cm²

Arc-rated clothing and equipment with an arc rating equal to or greater than the determined incident energy (See Note 3.)

Arc-rated long-sleeve shirt and arc-rated pants or arc-rated coverall or arc flash suit (SR) (See Note 3.)

Arc-rated face shield and arc-rated balaclava or arc flash suit hood (SR) (See Note 1.)

Arc-rated jacket, parka, or rainwear (AN)

Other PPE

Hard hat

Arc-rated hard hat liner (AN)

Safety glasses or safety goggles (SR)

Hearing protection

Heavy-duty leather gloves or rubber insulating gloves with leather protectors (SR) (See Note 4.)

Leather footwear

Table Method

▷ 12 cal/cm²

Arc-rated clothing and equipment with an arc rating equal to or greater than the determined incident energy
(See Note 3.)

Arc-rated long-sleeve shirt and arc-rated pants or arc-rated coverall and/or arc flash suit (SR)
Arc-rated arc flash suit hood
Arc-rated gloves
Arc-rated jacket, parka, or rainwear (AN)

Other PPE

Hard hat
Arc-rated hard hat liner (AN)
Safety glasses or safety goggles (SR)
Hearing protection
Arc-rated gloves or rubber insulating gloves with leather protectors (SR) (See Note 4.)
Leather footwear

Annex I Job Briefing

- Check list

Identify

- Hazards
- Voltage levels involved
- Skills required
- Any “foreign” (secondary source) voltage source
- Any unusual work conditions
- Number of people needed to do the job
- Shock protection boundaries
- Available incident energy
- Potential for arc flash (Conduct an arc flash hazard analysis.)
- Arc flash boundary

Ask

- Can the equipment be de-energized?
- Are backfeeds of the circuits to be worked on possible?
- Is a standby person required?

Check

- Job plans
- Single-line diagrams and vendor prints
- Status board
- Information on plant and vendor resources is up to date
- Safety procedures
- Vendor information
- Individuals are familiar with the facility

Annex I Job Briefing

- Check list

Know

- What the job is
- Who else needs to know — Communicate!
- Who is in charge

Think

- About the unexpected event . . . What if?
- Lock — Tag — Test — Try
- Test for voltage — FIRST
- Use the right tools and equipment, including PPE
- Install and remove temporary protective grounding equipment
- Install barriers and barricades
- What else . . . ?

Prepare for an emergency

- Is the standby person CPR trained?
- Is the required emergency equipment available?
Where is it?
- Where is the nearest telephone?
- Where is the fire alarm?
- Is confined space rescue available?
- What is the exact work location?
- How is the equipment shut off in an emergency?
- Are the emergency telephone numbers known?
- Where is the fire extinguisher?
- Are radio communications available?

Annex J

Energized Work Permit

- Give the example
- List a flow chart for how this is to be developed

ENERGIZED ELECTRICAL WORK PERMIT	
PART I: TO BE COMPLETED BY THE REQUESTER:	
	Job/Work Order Number _____
(1) Description of circuit/equipment/job location:	_____
(2) Description of work to be done:	_____
(3) Justification of why the circuit/equipment cannot be de-energized or the work deferred until the next scheduled outage:	_____
Requester/Title	Date
PART II: TO BE COMPLETED BY THE ELECTRICALLY QUALIFIED PERSONS DOING THE WORK:	
	Check when complete
(1) Detailed job description procedure to be used in performing the above detailed work:	<input type="checkbox"/>
(2) Description of the safe work practices to be employed:	<input type="checkbox"/>
(3) Results of the shock risk assessment:	<input type="checkbox"/>
(a) Voltage to which personnel will be exposed	<input type="checkbox"/>
(b) Limited approach boundary	<input type="checkbox"/>
(c) Restricted approach boundary	<input type="checkbox"/>
(d) Necessary shock, personal, and other protective equipment to safely perform assigned task	<input type="checkbox"/>
(4) Results of the arc flash risk assessment:	<input type="checkbox"/>
(a) Available incident energy at the working distance or arc flash PPE category	<input type="checkbox"/>
(b) Necessary arc flash personal and other protective equipment to safely perform the assigned task	<input type="checkbox"/>
(c) Arc flash boundary	<input type="checkbox"/>
(5) Means employed to restrict the access of unqualified personnel:	<input type="checkbox"/>
(6) Evidence of completion of a job briefing, including a copy of the permit (attach to permit):	<input type="checkbox"/>
(7) Do you agree the above-described work can be performed safely by the electrically qualified personnel (attach to permit):	<input type="checkbox"/>
Electrically Qualified Person(s)	_____
Electrically Qualified Person(s)	_____
PART III: APPROVAL(S) TO PERFORM THE WORK:	
Manufacturing Manager	_____
Safety Manager	_____
General Manager	_____
Note: Once the work is complete, forward this form to the requester.)	
© 2014 National Fire Protection Association	
NFPA 70E	

- ✓ Select Tool
- Hand Tool
- Marquee Zoom
- Previous View
- Rotate Clockwise
- Print... ⌘P
- Find
- Document Properties...

FIGURE J.1 Sample Permit for Energized Electrical Work.

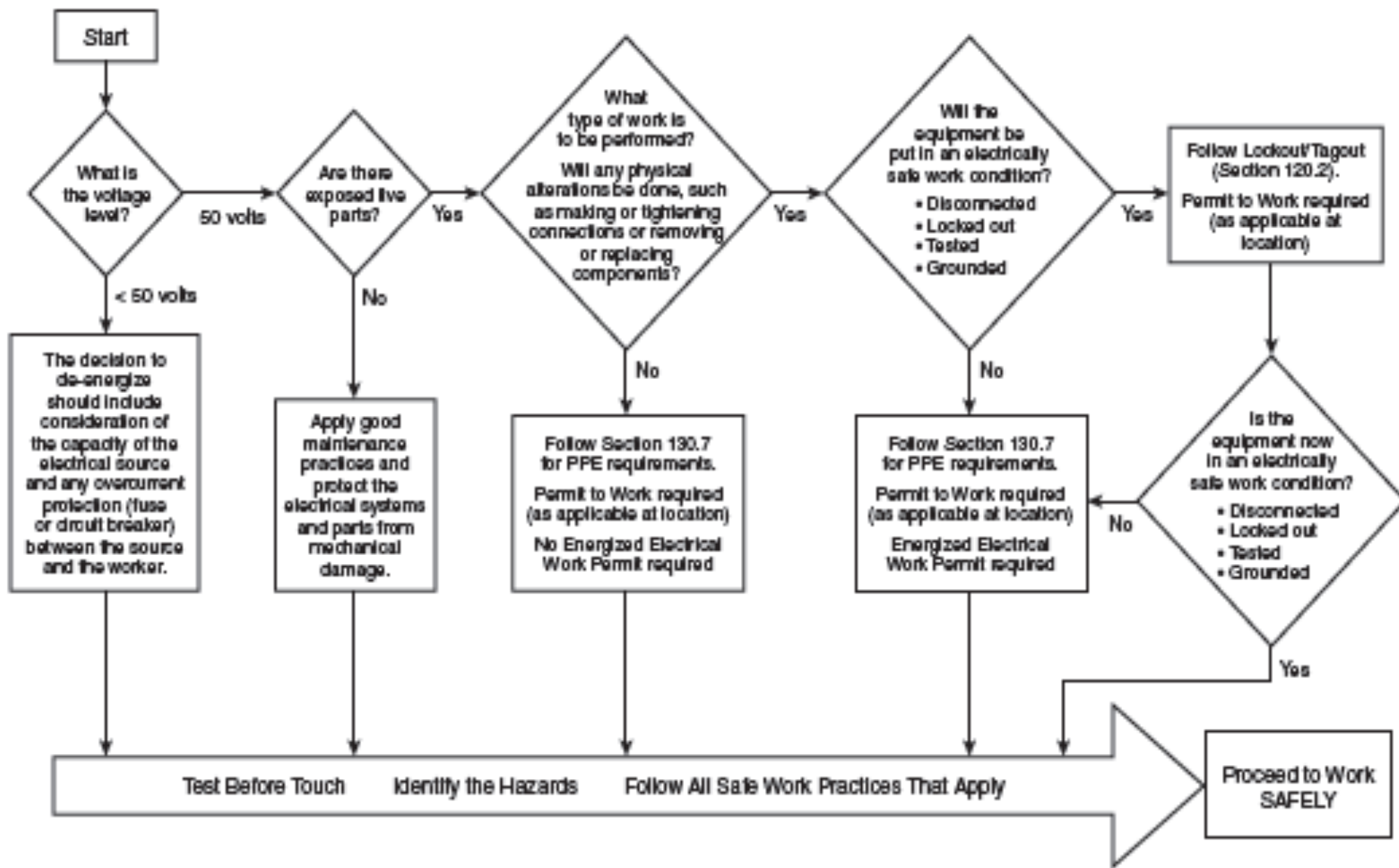

FIGURE J.2 Energized Electrical Work Permit Flow Chart.

Annex J-Energized Work Permit

- Part 1
 - Description and Justification by requester
- Part 2
 - Detailed job description
 - Results of shock risk assessment
 - Approach boundaries
 - Results of arc flash risk assessment
 - Barricades type
 - “Do you agree the work can be done safely?”
 - Signature
- Part 3
 - Management Signatures

Annex K Electrical Hazards

- **Electrical Shock**
 - 30,000 nonfatal shock occur every year
 - 1000 fatal electrocutions
 - Half of these are on systems less than 600 VAC
 - 4th leading cause of industrial fatalities- Traffic, homicide, construction accidents, electrocution
- **Electrical Arc Flash**
- **Electrical Arc Blast**

Fatalities 2003 – 2010 /BLS

COMMENTARY TABLE K.1 *Number of Deaths from Contact with Electricity, 2003 to 2010, by Employment*

<i>Employment</i>	<i>Number of Fatalities</i>
Electricians	300
Construction laborers	146
Electrical power line installers and repairers	132
Tree trimmers and pruners	79
Industrial machinery installation, repair, and maintenance employees	71
Heating, air conditioning, and refrigeration mechanics and installers	55
Driver/sales employees and truck drivers	50
Material moving employees	44

COMMENTARY TABLE K.2 *Percentage of Electrical Deaths, 2003 to 2010, by Activity*

<i>Percent of Electrical Fatality (percentage)</i>	<i>Activity</i>
45	Contact with overhead power lines
28	Contact with wiring transformers or other electrical components
18	Contact with electric current of machine, tool, appliance, or light fixture

Electrical Arc Flash

- 2000/yr are admitted to burn center for flash burns

Arc Blast

- Copper expanding to 67,000 times its volume as it is turned to vapor
- Pressure hundreds of psi, sound @ 160dB, and shrapnel @ 700mph
- $P = (11.5 \times I_a) / D^{0.9}$
- P = pressure (lb/ft²)
- I_a = arcing current (kA)
- D = distance from the center of the arc (ft)

Annex M layering of Protective Clothing

- Layering is an effective approach to achieving higher arc rating
- Natural fiber can ignite under arc-rated clothing
- Total system arc rating example:
 - Are rated overall (5cal) worn over
 - Arc rated long sleeve shirt and pants (5 cal)
 - ***This two layer approach would be good for 3 time the arc rating of the individual layers would be over 20cal/cm²***
- ***Manufacturer provide layer ratings for their clothes***

Sallsbury pro-wear color code	Hazard risk category (HRC)	Clothing description (Typical number of clothing layers given in parentheses)	Minimum arc thermal performance exposure value (ATPV) rating of PPE
Navy blue	1	FR long-sleeve shirt and FR pants or FR coverall plus arc-rated face shield or switching hood (1)	4 cal/cm ²
	2	FR long-sleeve shirt and FR pants or FR coverall plus switching hood (or face shield with balaclava) (1 or 2)	8 cal/cm ²
Royal blue	3	FR long-sleeve shirt and FR pants or FR coverall and FR jacket and FR pants or total FR clothing system with hood (2 or 3)	25 cal/cm ²
Gray/Khaki	4	FR long-sleeve shirt and FR pants or FR coverall and FR jacket and FR pants or total FR clothing system with hood (2 or 3)	40 cal/cm ²

Liquid Electrolyte

- Goggles and face shield
- Gloves and apron
- Portable or stationary eye wash facilities



Probability of
Injury 40.9 cal
rated PPE

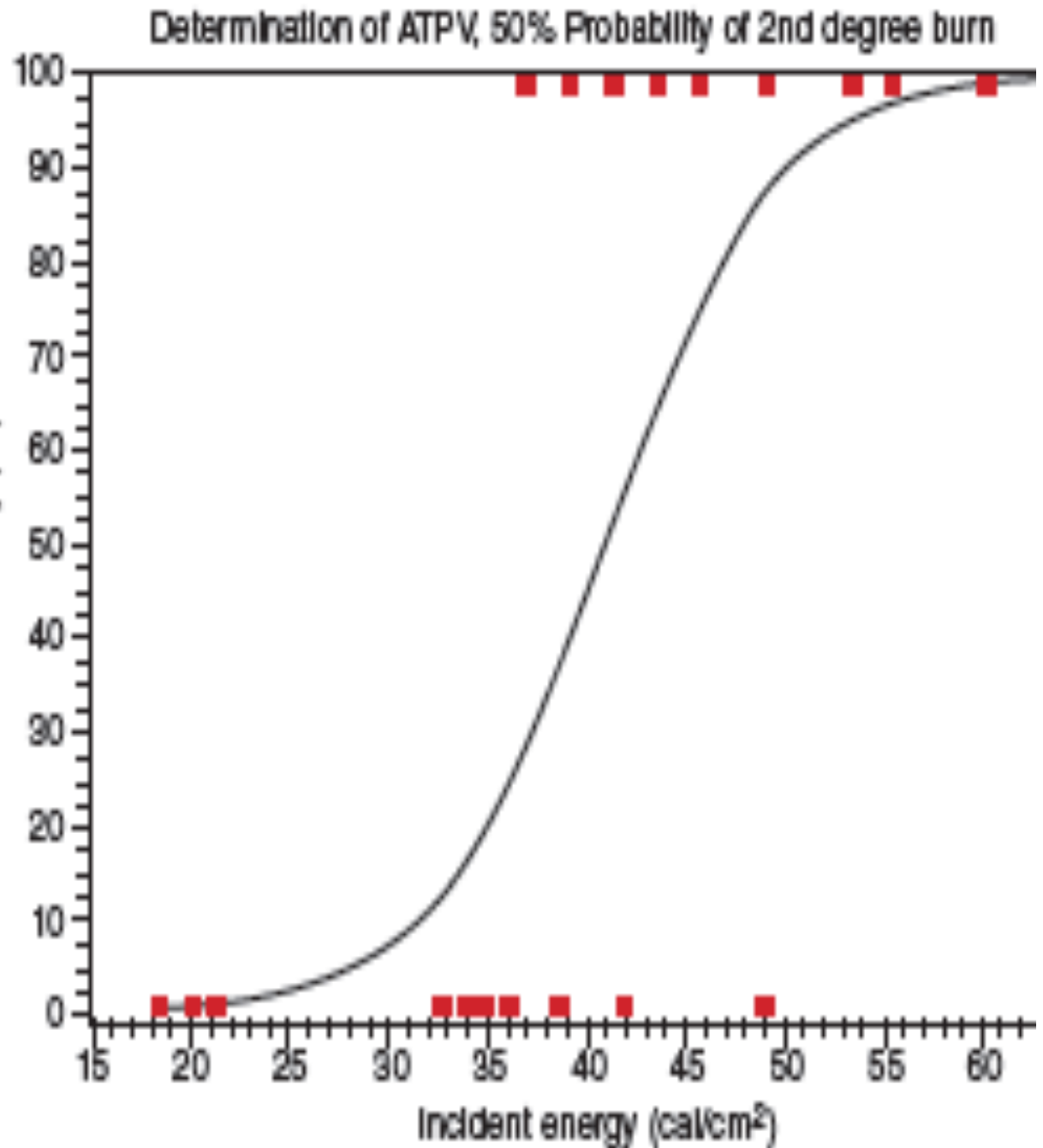

Annex N Overhead Line

- Employees not place themselves in close proximity to overhead power lines. “Close proximity” is within a distance of 10 ft. for systems up to 50 kV, increased 4 in. for every 10 kV above 50 kV.
- Employees be informed of the hazards and precautions when working near overhead lines.
- Warning decals be posted on cranes regarding the minimum clearance of 3 m (10 ft.).

Annex N Overhead Lines

- A “spotter” be designated when equipment is working near overhead lines. This person’s responsibility is to observe safe working clearances around all overhead lines and to direct the operator accordingly.
- Warning cones be used as visible indicators of the 3 m (10 ft.) safety zone
- That the local responsible person be notified at least 24 hours before any work begins to allow time to identify voltages and clearance requirements

Annex O Safety Related Design

- Perform electrical hazard risk assessment during the design
- Eliminate hazards or reduce the risk via designs
 - Reduce the likely hood
 - Reduce the severity
 - Enable a safe work condition

Annex O Cont.

- Incident energy reduction methods
 - Zone selective interlocking
 - Differential relaying
 - Energy reducing maintenance switches
 - Crow bars and arc Vaults
 - Arc flash relaying
 - High resistance grounding
 - Current limiting devices

Annex P AIHA Z10 Safety Management

- ANSI/AIHA Z10 Std for Occupational Health and Safety Mgmt. Systems
 - Sets minimum safety requirements for
 - Management
 - Employees
 - Planning
 - Evaluation
 - Corrective action
 - PLAN-Do-Check-Act
 - Target audience is the Safety Professional

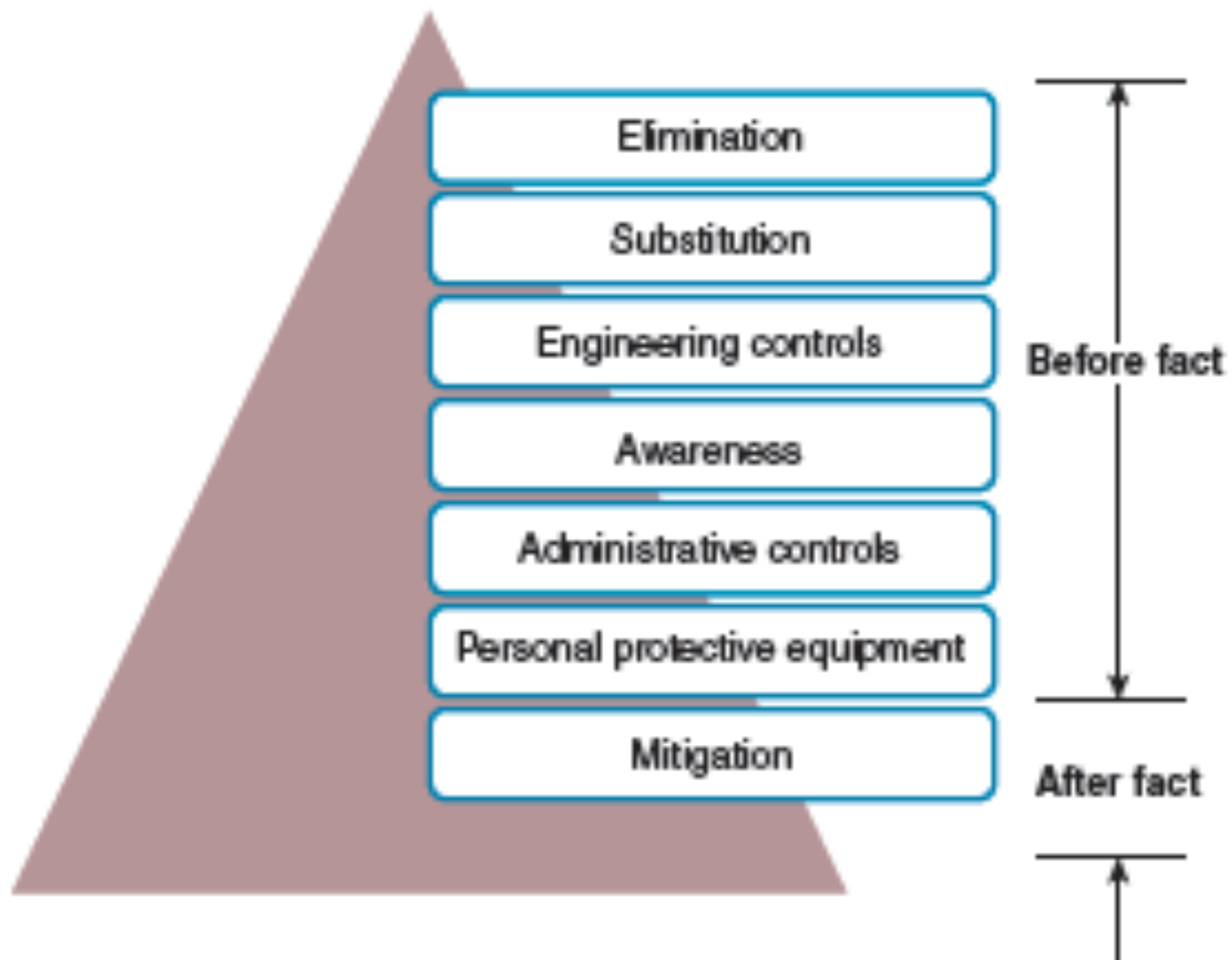

Annex P

- Always use the highest level of control
- A combination is advised when using lower order controls
- Examples
 - Arc rated switchgear = substitution or engineering control
 - Job planning, training, and temp barricades = Administrative control
 - Incident response plan = mitigation

Conditions of Acceptable Risk

- Equipment Properly Installed
- Equipment Maintained
- Equipment Doors are Secured
- No Evidence of Impending Failure
- The equipment is used according to manufacture's instructions

THE END



ARC FLASH MITIGATION FOR 1500 SUBSTATIONS A CORPORATE APPROACH

~~Rakan El-Mahayni~~ — ~~Jamal Bugshan~~ — ~~Ritchie~~
Pragale

SAUDI ARAMCO

2015 Petroleum and Chemical Industry Committee Technical Conference
Houston, Texas – October 5-7, 2015



OUTLINE

Introduction

Arc Flash Studies

**Technology Evaluation and
Planning**

Conclusion

Introduction

- Large Oil and Gas company with more than 1500 Substations
- Five Years Master Power Systems Plan including AF Mitigation
- Ongoing arc flash studies for new and existing facilities
- “Dangerous” arc flash locations are somewhat consistent:
 - Budgeting for implementing AF mitigation becomes predictable
 - Engineering and Material standards can be modified

Current Status

- General Instruction Document (Existing Facilities):
 - Heavily focused on PPE
 - Remote Racking Devices and PPE in all substations
 - Using Remote Switching when available (mostly MV)
- Engineering Standard Document (New Projects):
 - Arc Flash studies for all equipment rated 38 kV and below
 - Arc Flash Incident Energy must be below 8 cal/cm²

OUTLINE

Introduction

Arc Flash Studies

Technology Evaluation and
Planning

Conclusion

13.8 kV System- Scheme I

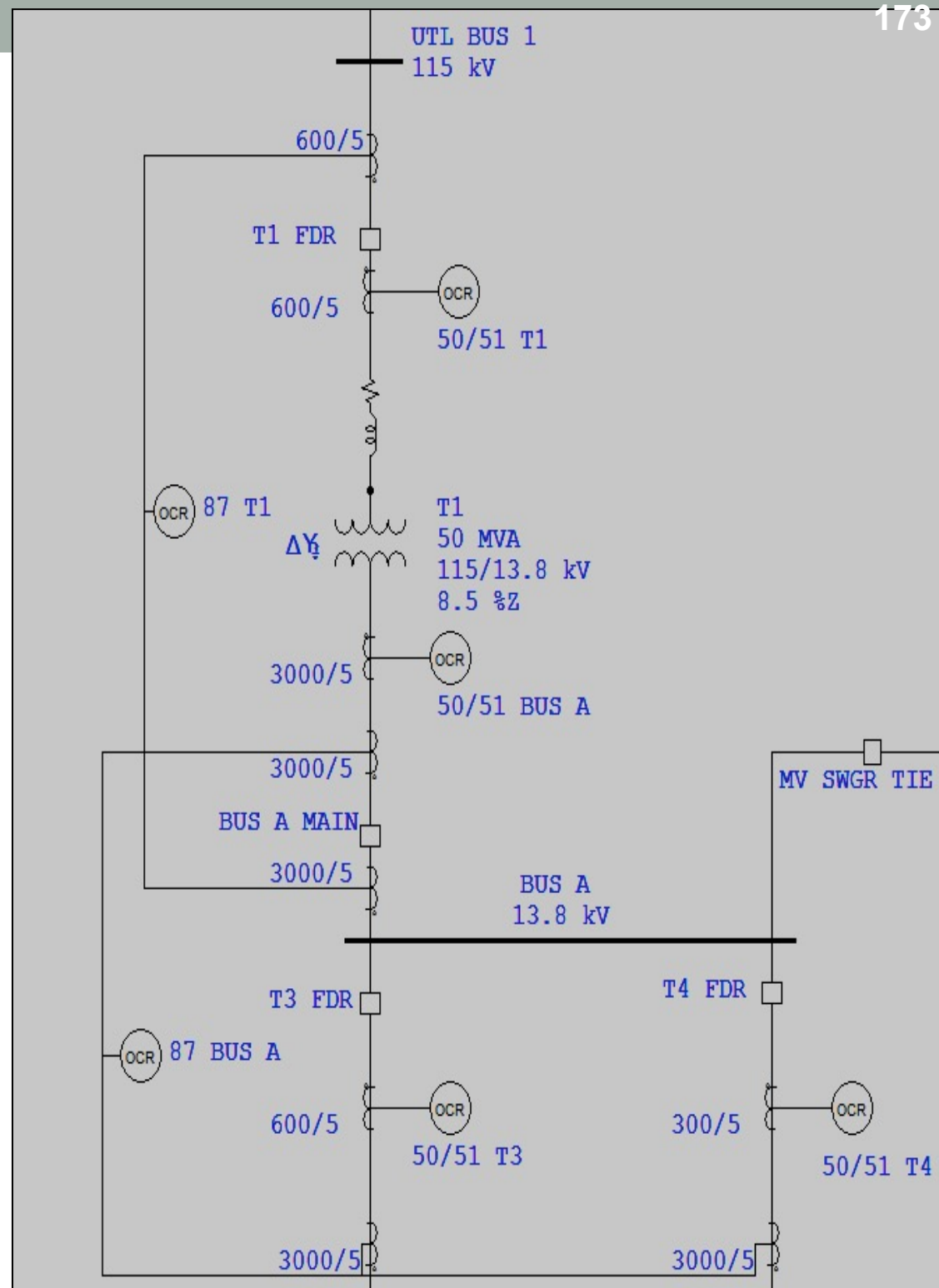

4.16 kV System- Scheme II

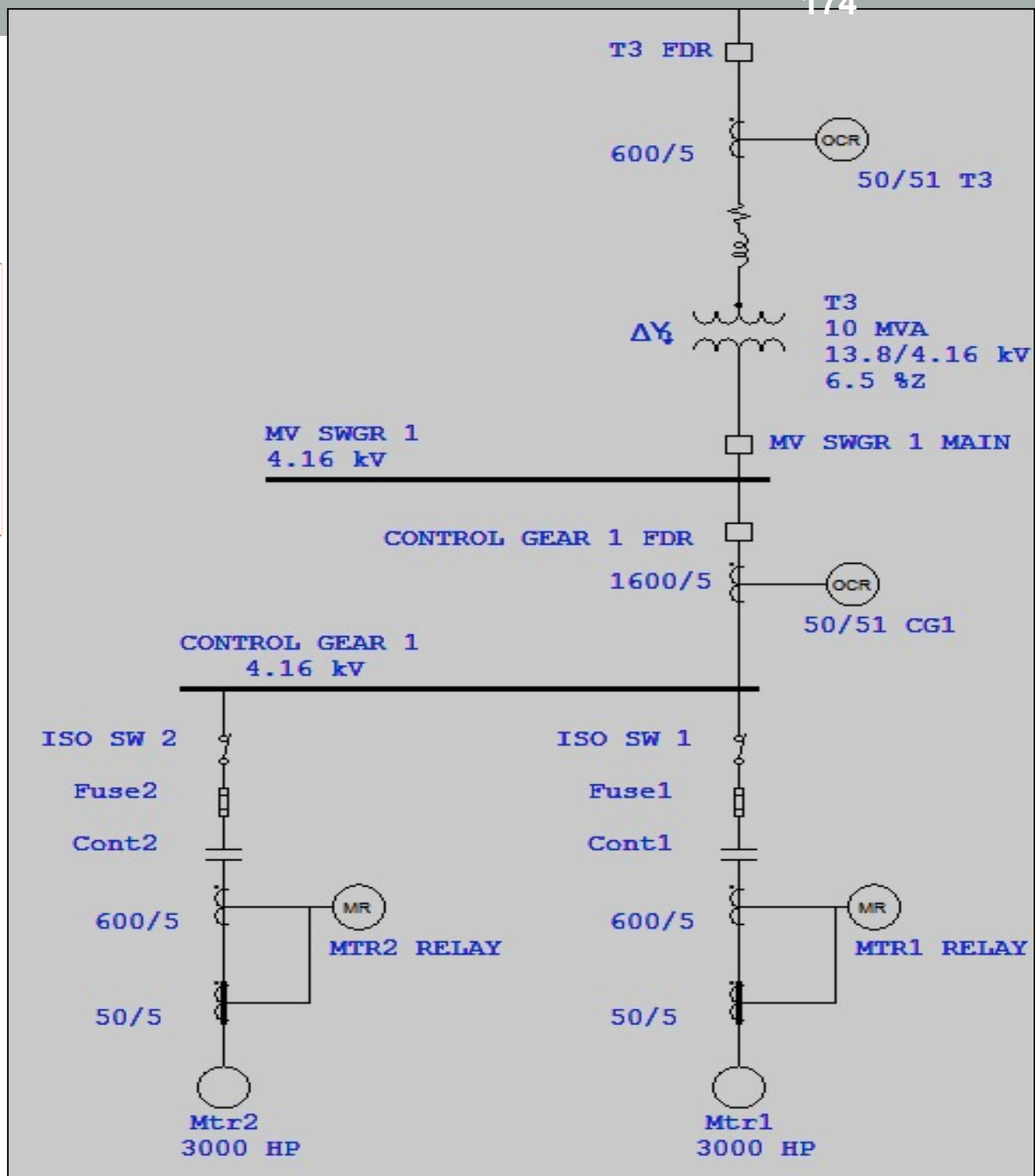

0.48 kV System- Scheme III

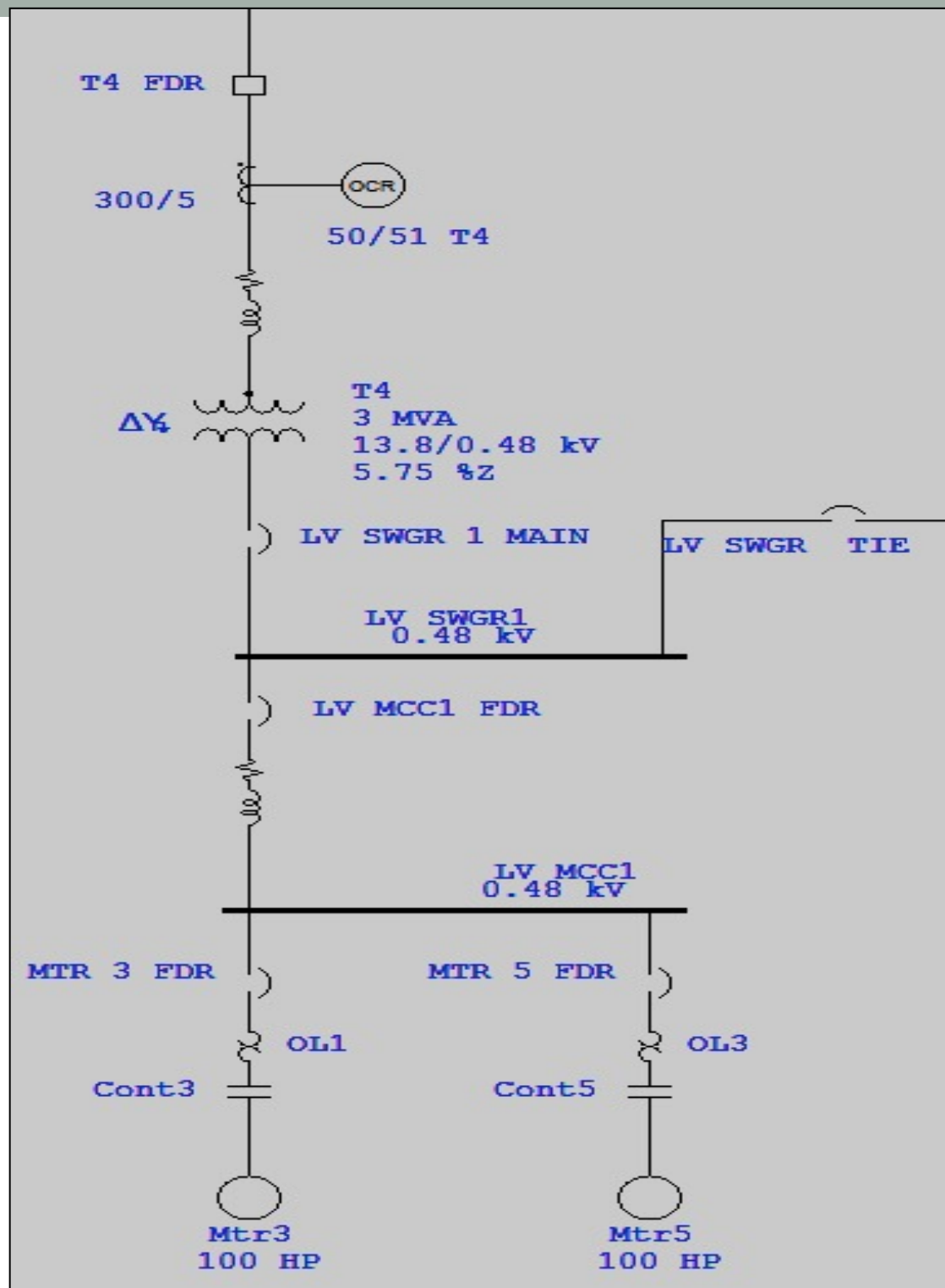

AF Study Road Map

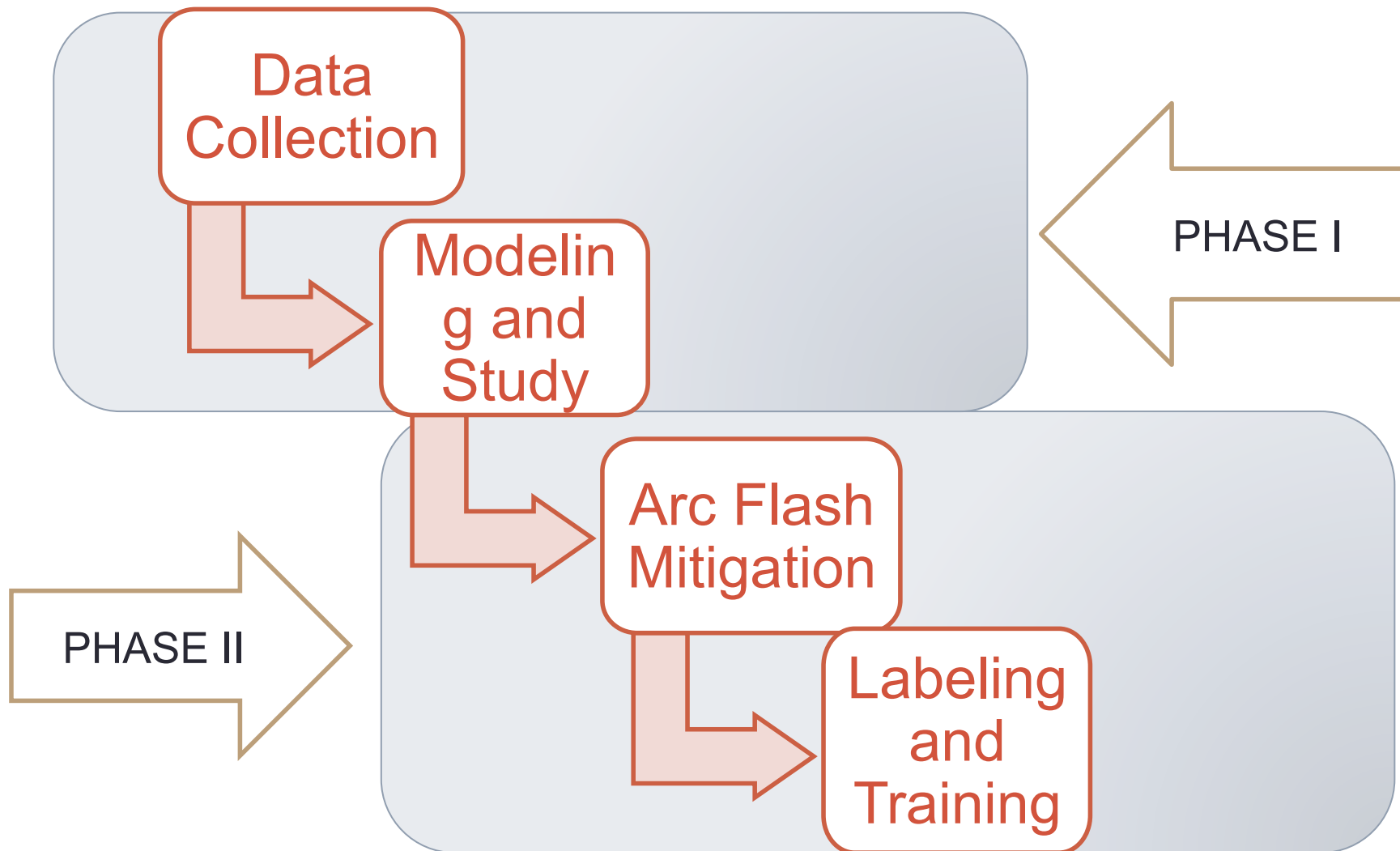

Arc Flash Study Results

Facility	A	B	C	Danger	LV Line Side (%)
F1	1	53	92	57	46
F2	381	136	206	132	55
F3	1	198	59	152	50
F4	4	81	96	30	90

Energy Levels per NFPA 70E-2012- Annex H

Minimum Calculated Incident Energy (cal/cm ²)	Maximum Calculated Incident Energy (cal/cm ²)	Arc Flash Level
0.0	1.2	A
>1.2	12	B
>12	40	C
>40	40+	DANGER

Line Side Energy

Amps X 10 BUS A (Nom. kV=13.8, Plot Ref. kV=13.8)

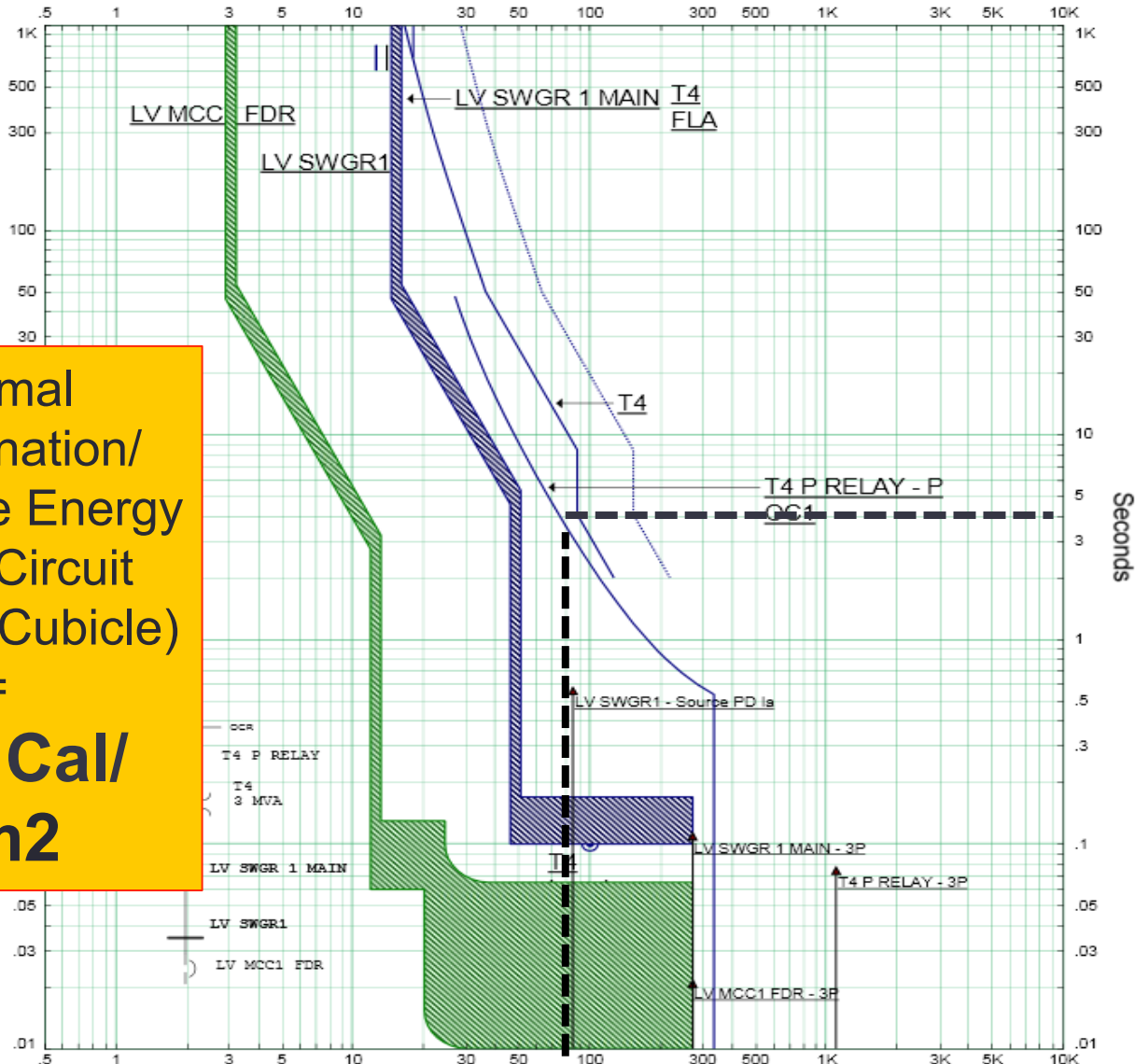

Normal
Coordination/
Line Side Energy
(Main Circuit
Breaker Cubicle)
=
**118 Cal/
cm²**

4 Seconds

OUTLINE

Introduction

Arc Flash Studies

**Technology Evaluation and
Planning**

Conclusion

Feedback on Technologies

Remote Racking/Distance



Optical Sensor/Time

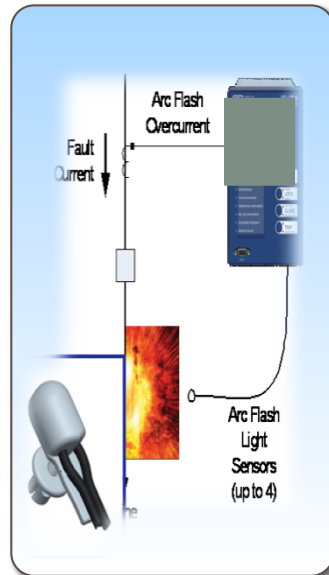

Maintenance Switch/Time



Crowbar/Time



Bus Differential/Time

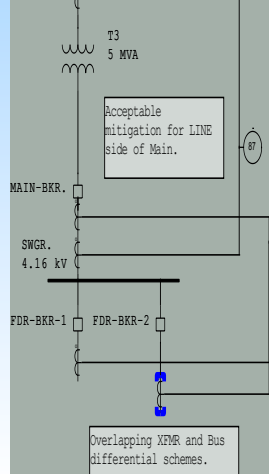

Zone Selective/Time

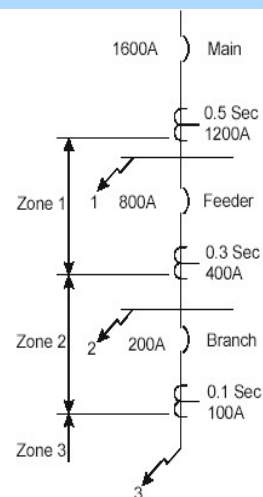

Remote switching / Distance

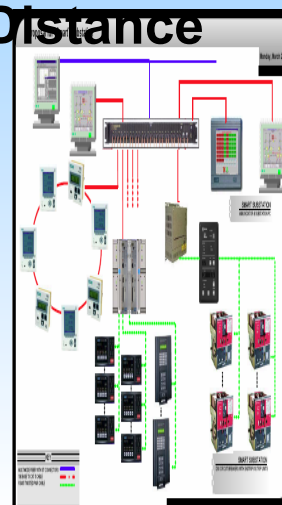

AR Switchgear / Time & Dist



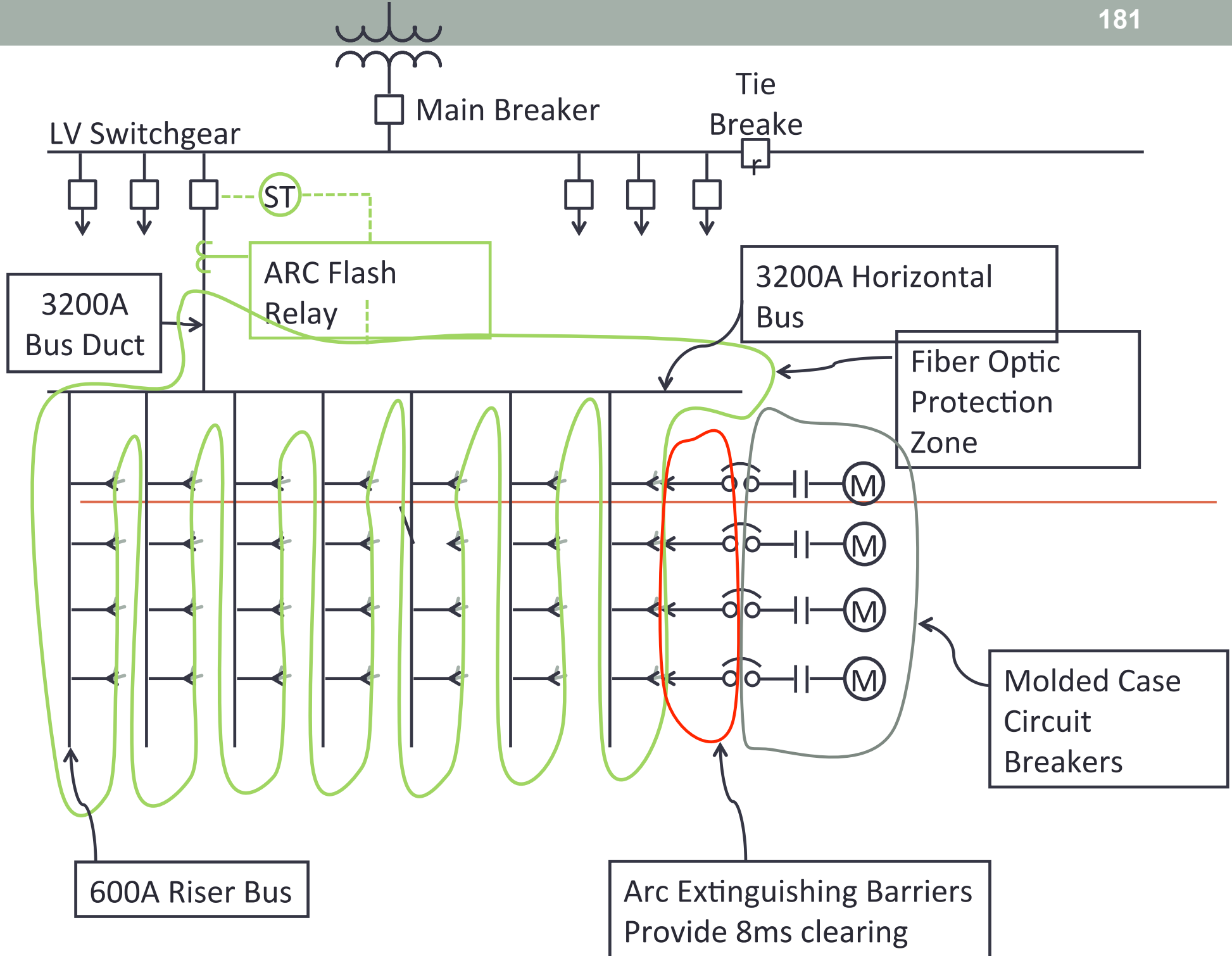

Feedback on Technologies

ERMS (Energy Reducing Maintenance Switch)

Benefits

-
-



ance (less

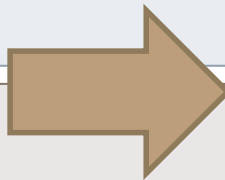

ination dur
could be fo

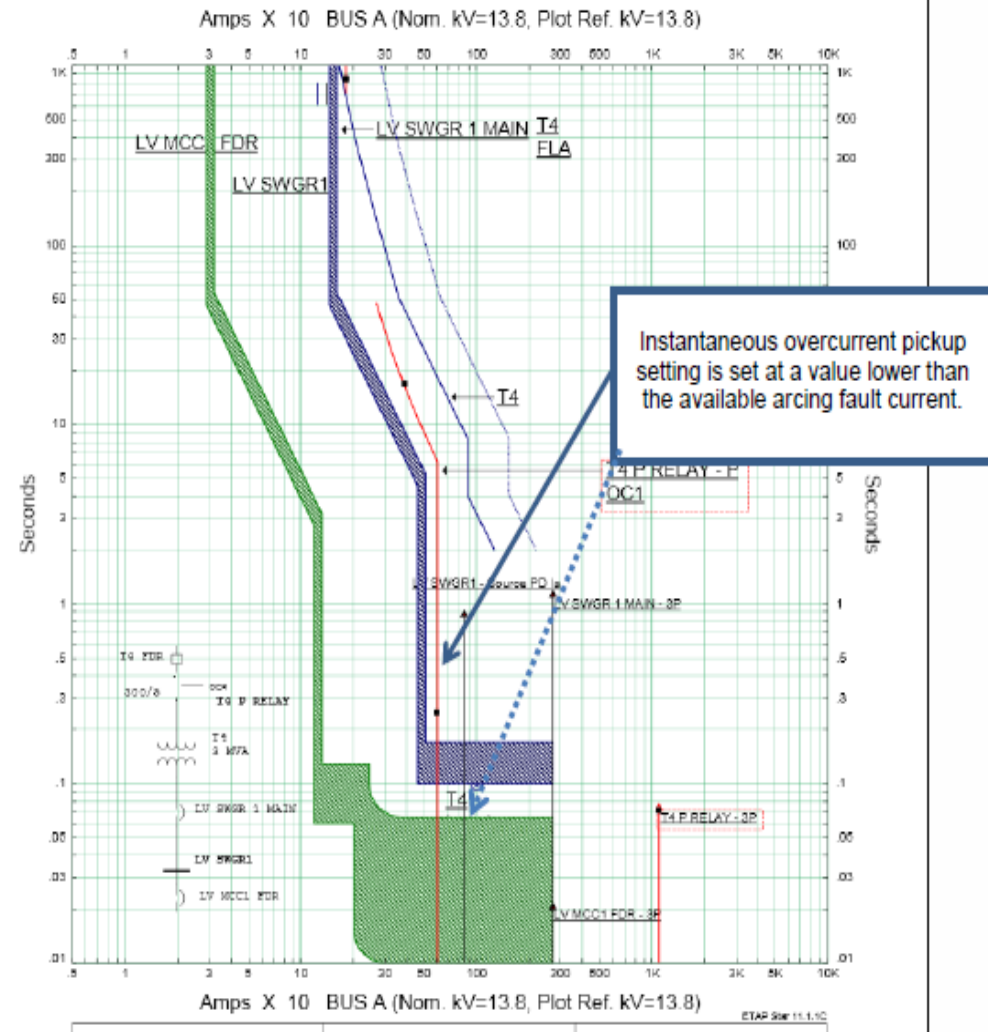

Feedback on Technologies

Line Side Energy Resolution

To 6 Cal/
Cm²

From 118
Cal/Cm²

Coordination/Line
Side Energy (Main
Circuit Breaker
Cubicle)

Maintenance
Coordination/
Line Side
Energy

Instantaneous overcurrent pickup
setting is set at a value lower than
the available arcing fault current.

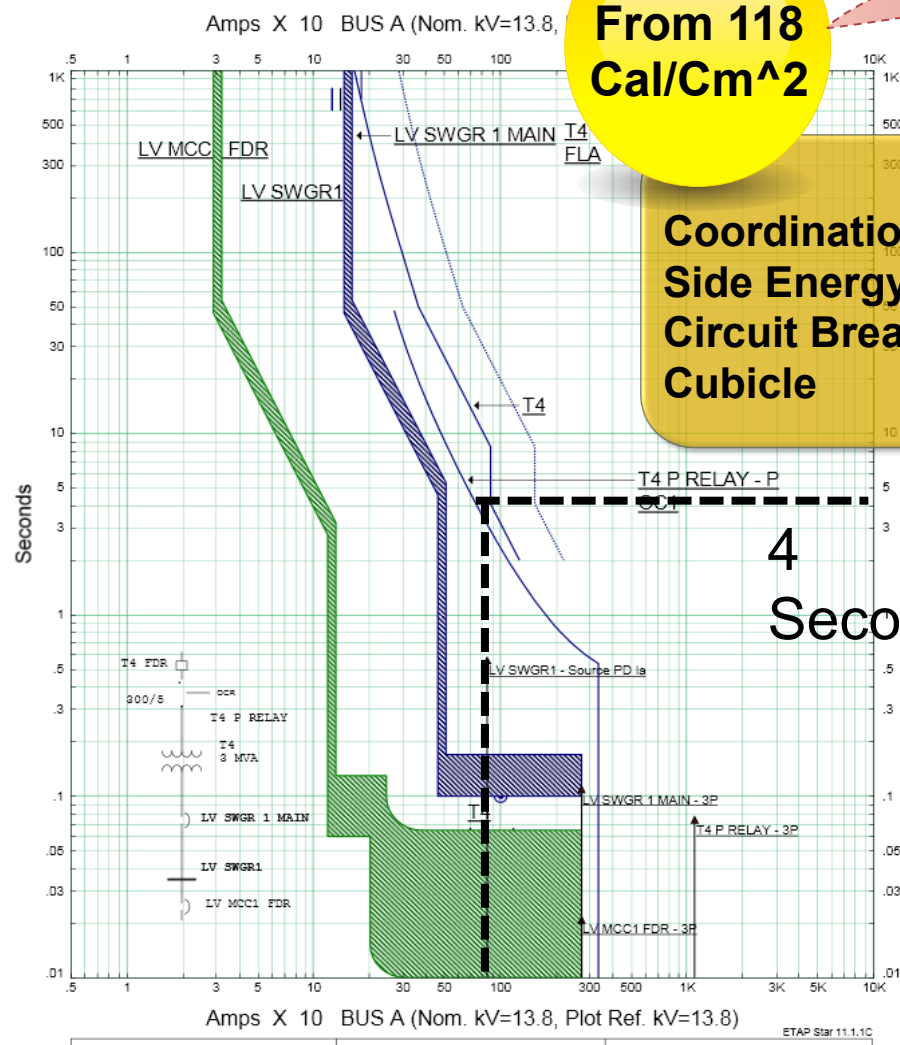

4
Seconds

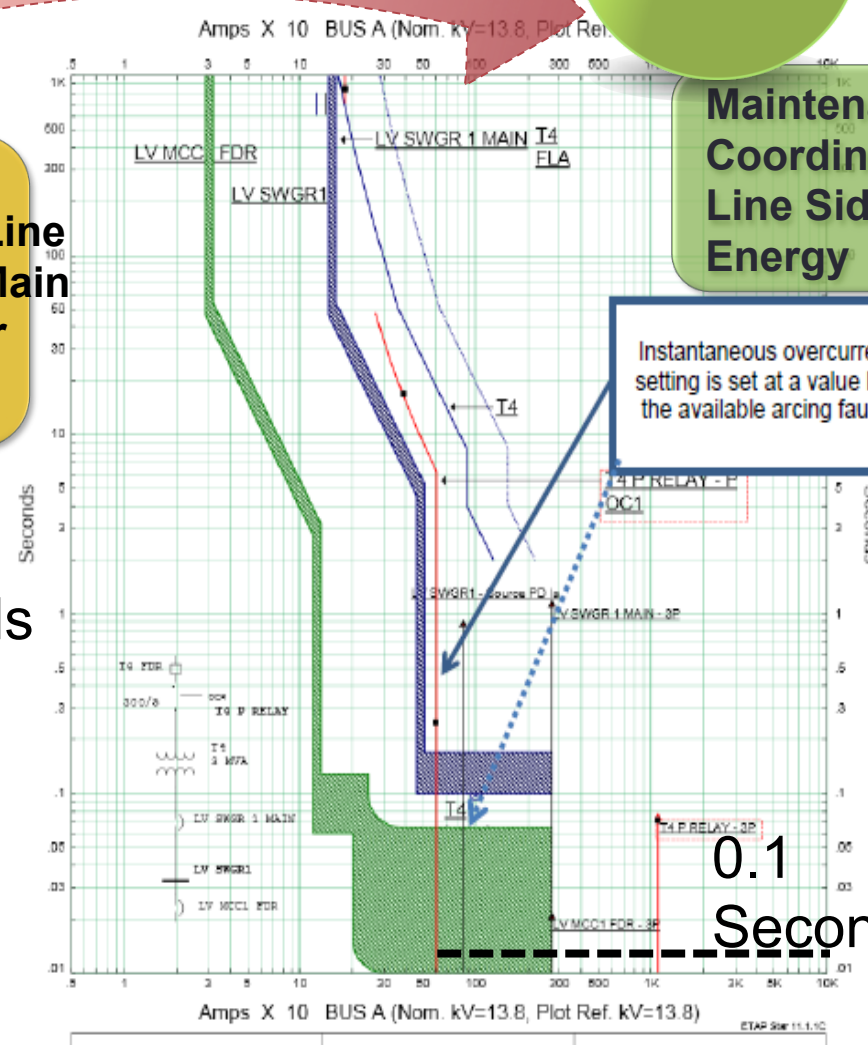

0.1
Second

ERMS AF Results

S.No	ETAP ID	kV (kV)	Type	Existing Scenario		Recommendation	Proposed Scenario	
				Total Energy (cal/cm ²)	Energy Levels		Total Energy (cal/cm ²)	Energy Levels
1	A-P-LVSG-01 IN	0.48	LV CB	42.96	> Danger	Maintenance Switch	6.71	Level B
2	CB56	0.48	LV CB	73.15	> Danger		7.32	Level B
3	CB635	0.48	LV CB	53.37	> Danger		7.12	Level B
4	CB843	0.48	LV CB	43.19	> Danger		6.75	Level B
5	CB846	0.48	LV CB	23.57	Level C	Maintenance Switch	7.19	Level B
6	EC-P-B-02	0.48	LV CB	39.27	Level C		6.54	Level B
7	EC-P-B-6	0.48	LV CB	39.94	Level C		6.66	Level B
8	EC-P-B-8	0.48	LV CB	35.19	Level C		6.77	Level B
9	EC-P-LVSG-04 IN	0.48	LV CB	25.67	Level C	RELT	6.42	Level B
10	30-P-LVSG-01 IN	0.48	LV CB	24.17	Level C		3.18	Level B
11	A-P-LVSG-002A IN	0.48	LV CB	11.58	Level B		3.62	Level B
12	A-P-LVSG-002B IN	0.48	LV CB	19.46	Level C		3.6	Level B
13	CB1658	0.48	LV CB	13.39	Level C		2.09	Level B
14	EC-P-B7	0.48	LV CB	12.72	Level C		1.99	Level B

Feedback on Technologies

Zone Selective Interlock

• Benefits

- No intentional delay for bus side faults
- Reasonable cost when pre specified

• Limitations

- Does not reduce line side arc flash energy
- Does not function when fault is less than

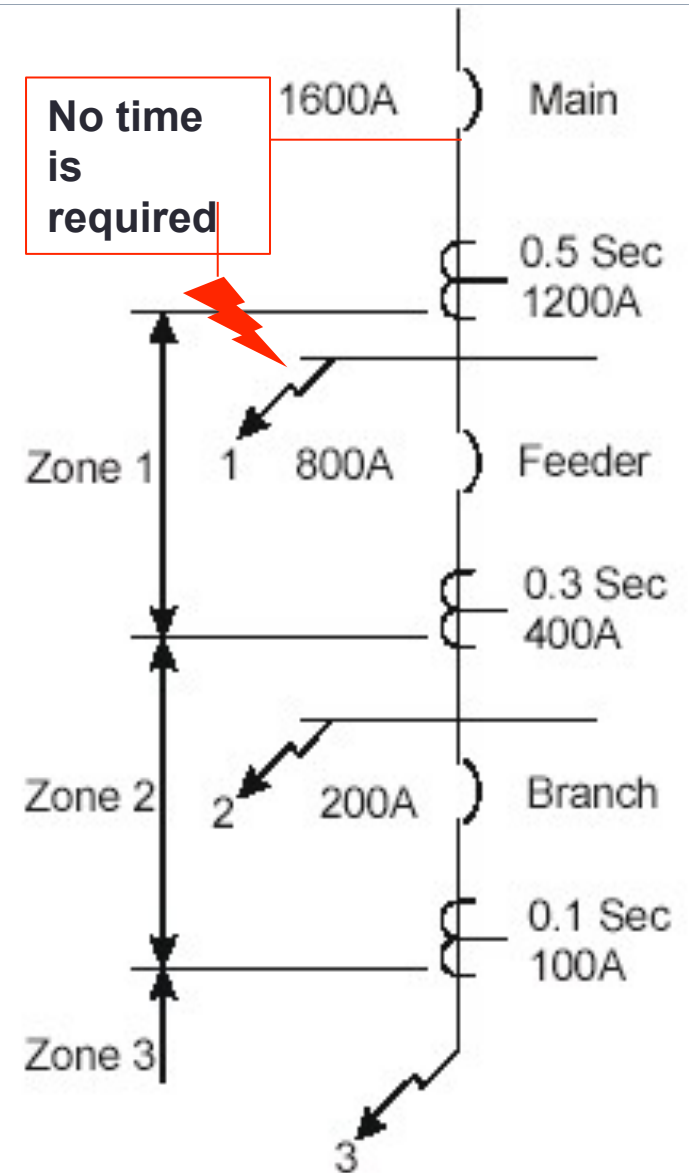

Feedback on Technologies Remote Racking Device

- **Benefits**

- Reduced energy by increasing distance
- Universal application for various
- Reasonable cost

- **Limitations**

- Local customer support
- Torque calibration
- Limited mobility
- Applicable only for racking procedures



Feedback on Technologies

Optical Sensor

• Benefits

- Fast Operating time.
- No interface with layers
- Many compartments covered



CURRENT SENSORS



Arc
Detection
Relay

Incomer
Breaker

TRIP COMMAND



• Limitations

- Only retrofitting on existing equipment.
- Manufacturer Certification
- Sensor Replacement

Breaker



LIGHT SENSOR

Extended ZSI

To be Evaluated

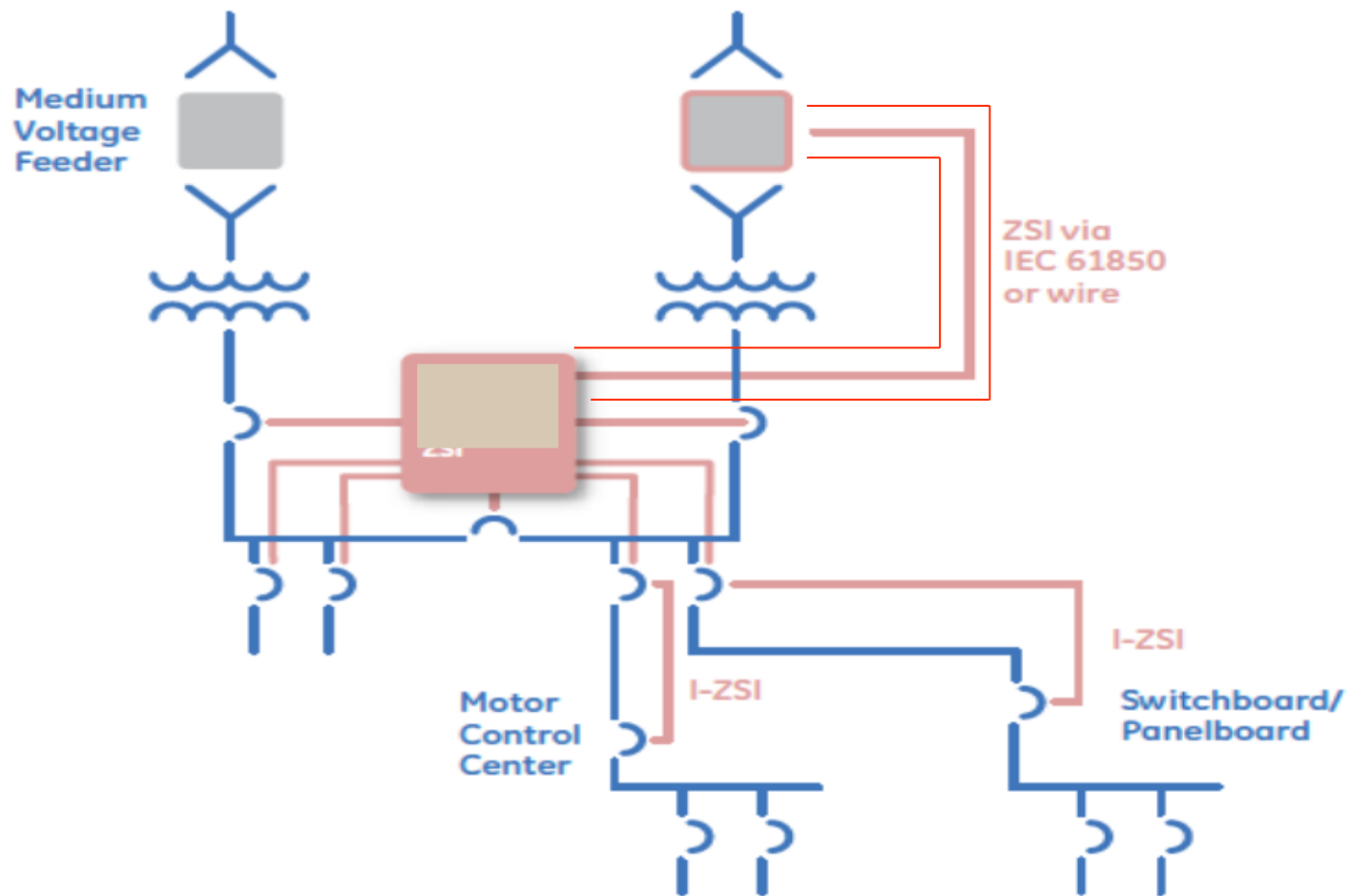

Other Solutions

LVCB Characteristics Emulation

**From 118
Cal/Cm²**

**To 23
Cal/Cm²**

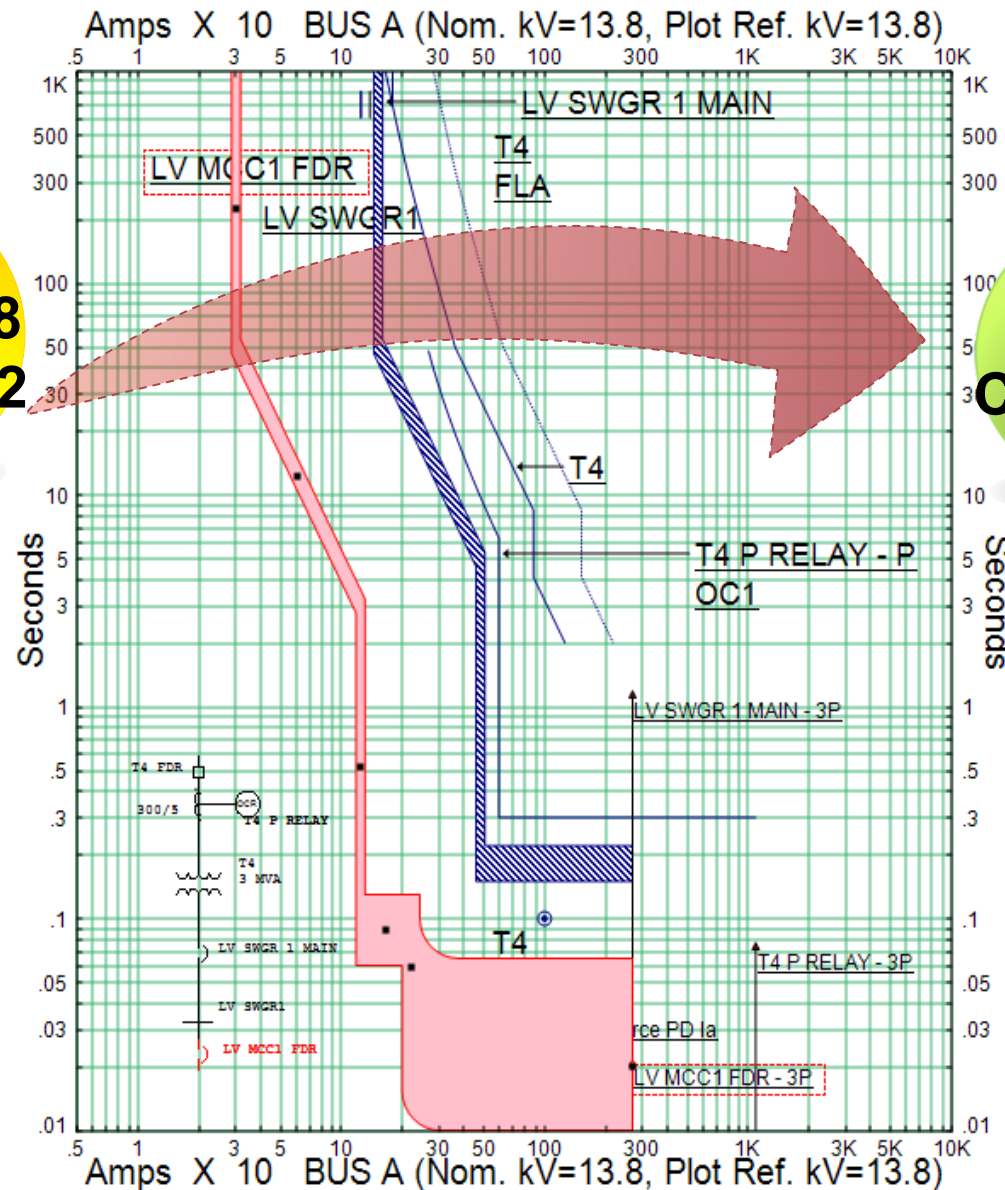

Solution Matrix

	Suggested Solution	Component Description	Quantity	Remarks
Type III Scheme	Digital Trip Units/ ERMS	LV main circuit breakers	950	Replace trip units of 480 V main power circuit breakers
	Digital Trip Units/ ERMS	LV outgoing feeder circuit breakers	2147	Replace trip units of 480 V feeder power circuit breakers
Type II & Type III Schemes	Micro Processer Relays/ ERMS	Power transformer feeders	1358	Replace overcurrent protective relays of feeder circuit breakers upstream of power transformers
Type II Scheme	Micro Processer Relays/ ERMS	4.16 kV MCCs	225	Replace overcurrent protective relays of feeder circuit breakers upstream of MV motor control centers (directly fed motors are not counted)

Standard Update

- Specify Bus Differential Schemes for 4.16 kV Switchgears
- ERMS with all outgoing transformer feeders
- ERMS with all outgoing power circuit breakers

OUTLINE

Introduction

Arc Flash Studies

Technology Evaluation and
Planning

Conclusion

Conclusion

Typical locations with excessive arc flash incident energy were identified

Line side of low voltage switchgear constitute a substantial portion of the overall dangerous locations

Combined effort can move mitigation into feed stage of new projects

Energy Reducing Maintenance Switch effective in reducing line side arc flash incident energy at low voltage switchgear

Extended ZSI to be considered



ARC FLASH MITIGATION FOR 1500 SUBSTATIONS A CORPORATE APPROACH

~~Rakan El-Mahayni~~ — ~~Jamal Bugshan~~ — ~~Ritchie~~
Pragale

TI PAID

2015 Petroleum and Chemical Industry Committee Technical Conference

Houston, Texas – October 5-7, 2015





LVMCC Self-EX Modification Program



A tested method for mitigating arc flash hazards in existing LV Motor Control Centers.

Supplemental to NFPA 70E and IEEE 1584

Allows open door troubleshooting of LV Motor Control Center bucket components with a reduced level of PPE

LVMCC Self-EX Modification Program

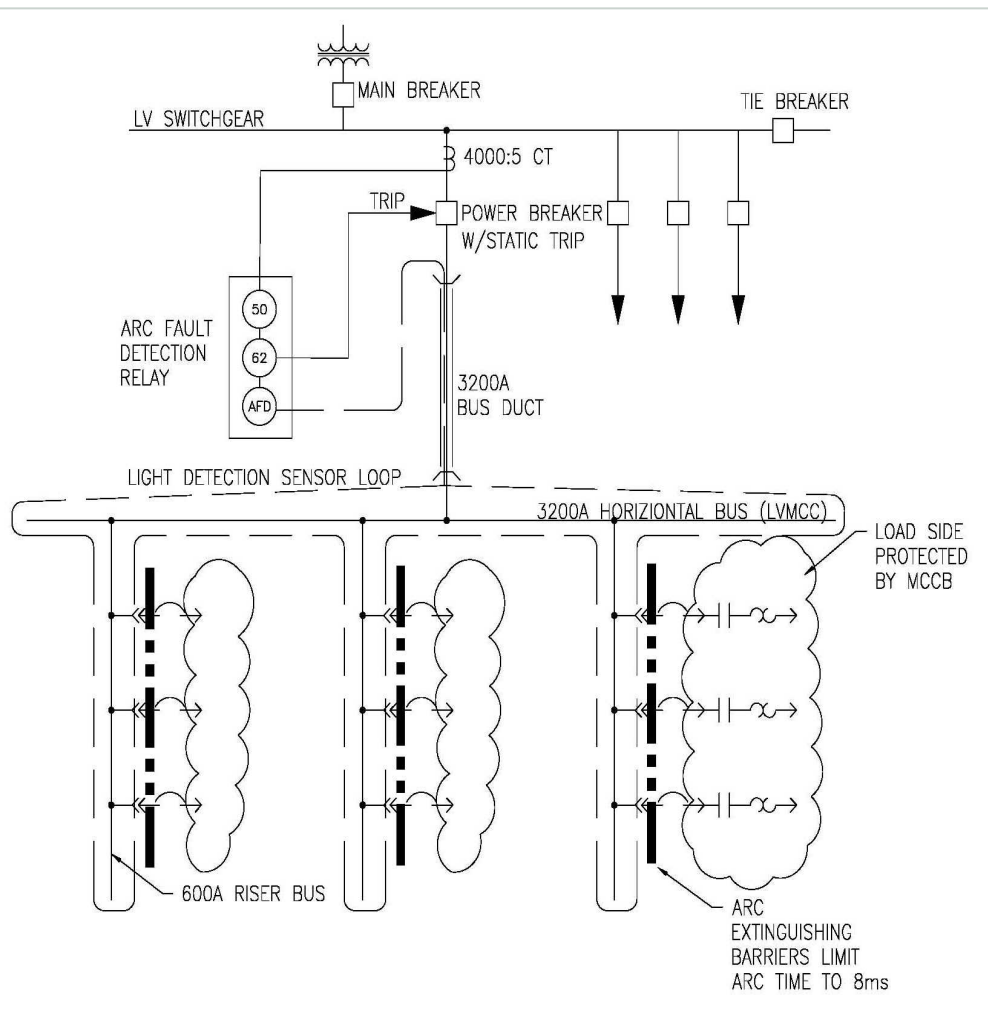

Summary of Program

1. Addition of arc-extinguishing barriers within the bucket on the line side of the MCCB/MCP
2. Addition of Light Detection Sensors in the rear of the LVMCC
3. Insulation of Main Horizontal Bus at end of lineup
4. Addition of Arc Fault Detection Relay and CT's to LV Feeder Breaker
5. (Optional) Addition of Light Detection Sensors in Bus Duct

Bucket Modifications

- Glass Polyester breaker cover on MCCB secured with a heavy duty cable tie
- Braided tin copper sleeves added to the line side of the MCCB and grounded to the bucket ground tab.
- Stab Assembly sealed with silicone caulk/insulating material



Structure Modifications

- Light Detector sensors looped in rear of LVMCC as shown
- Can be added from the end of the LVMCC without removing rear panels.
- Small junction box for connection to fiber to Arc Flash Detection Relay
- Ends of main horizontal bus insulated fully



LV Switchgear Modifications

- Addition of CT in Feeder Breaker Circuit
- Addition of trip circuit in Feeder Breaker (Shunt trip or existing)
- Addition of Arc Flash Detection Relay
- Relay could be remotely mounted

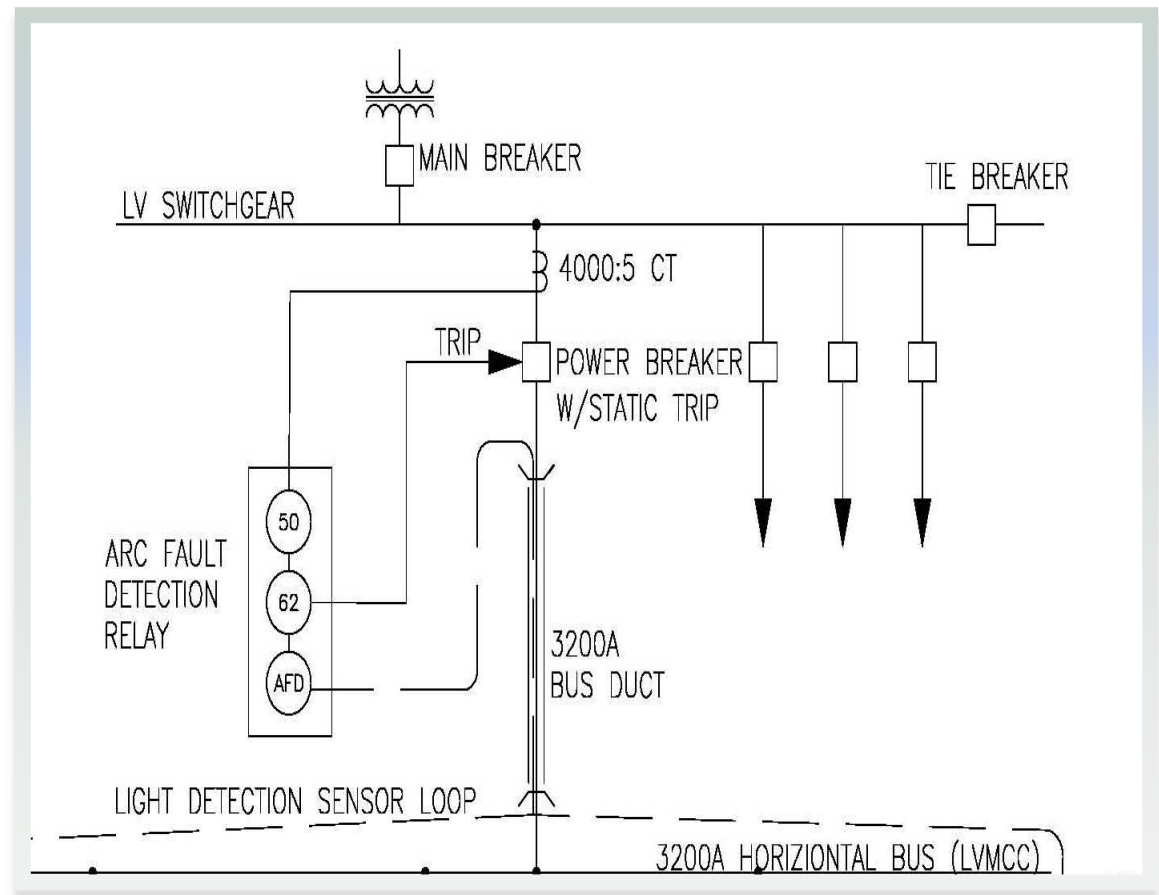

Arc Flash Detection Relays



- Different models available
- 360° Fiber Optic sensors applied in a loop in rear of LVMCC
- Radius Supports to avoid sharp bends
- Installed from end of LVMCC
- Relays can be mounted in existing switchgear or separate panel
- CT's required

Results - Typical Arc Extinguishing Pattern

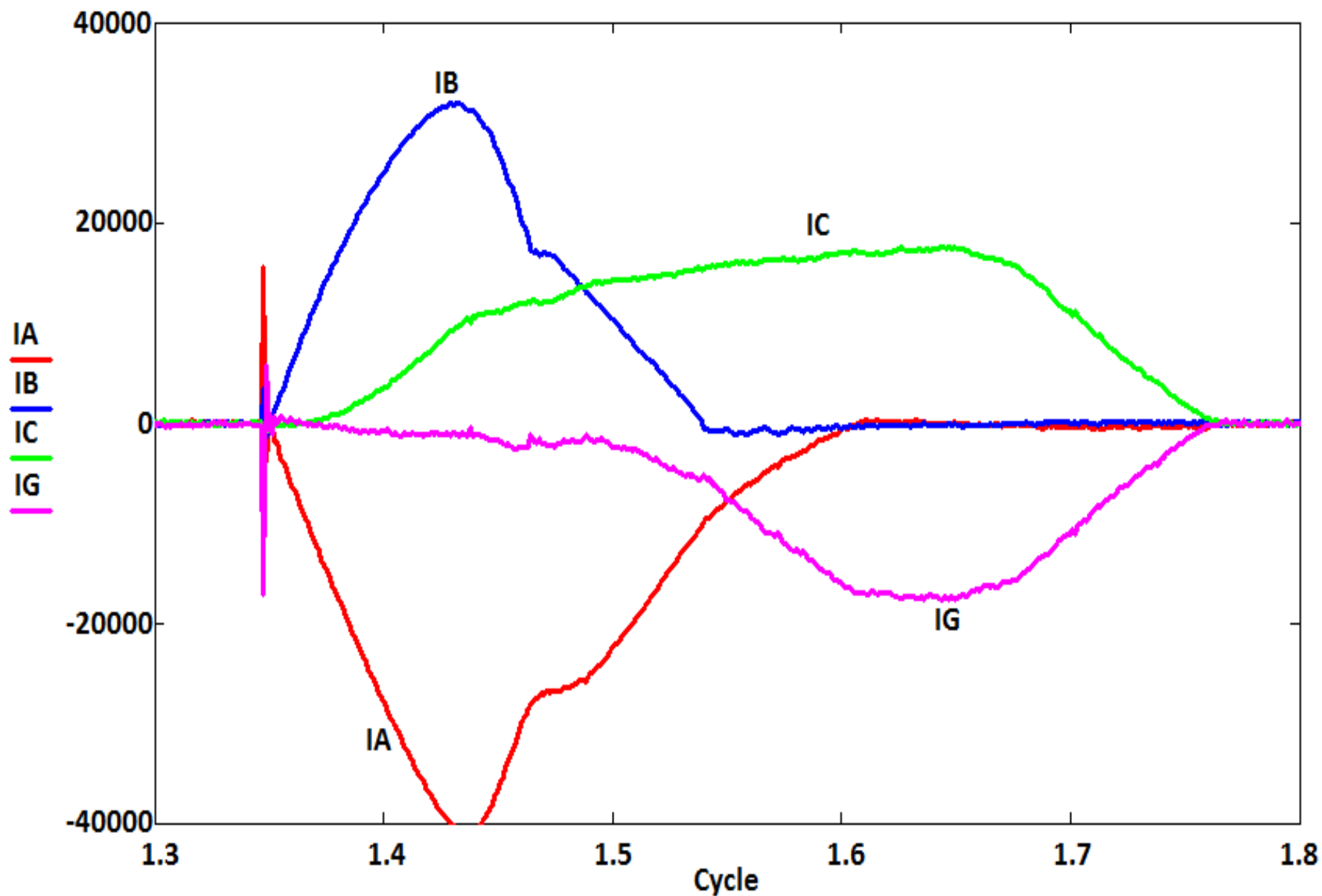

Results -

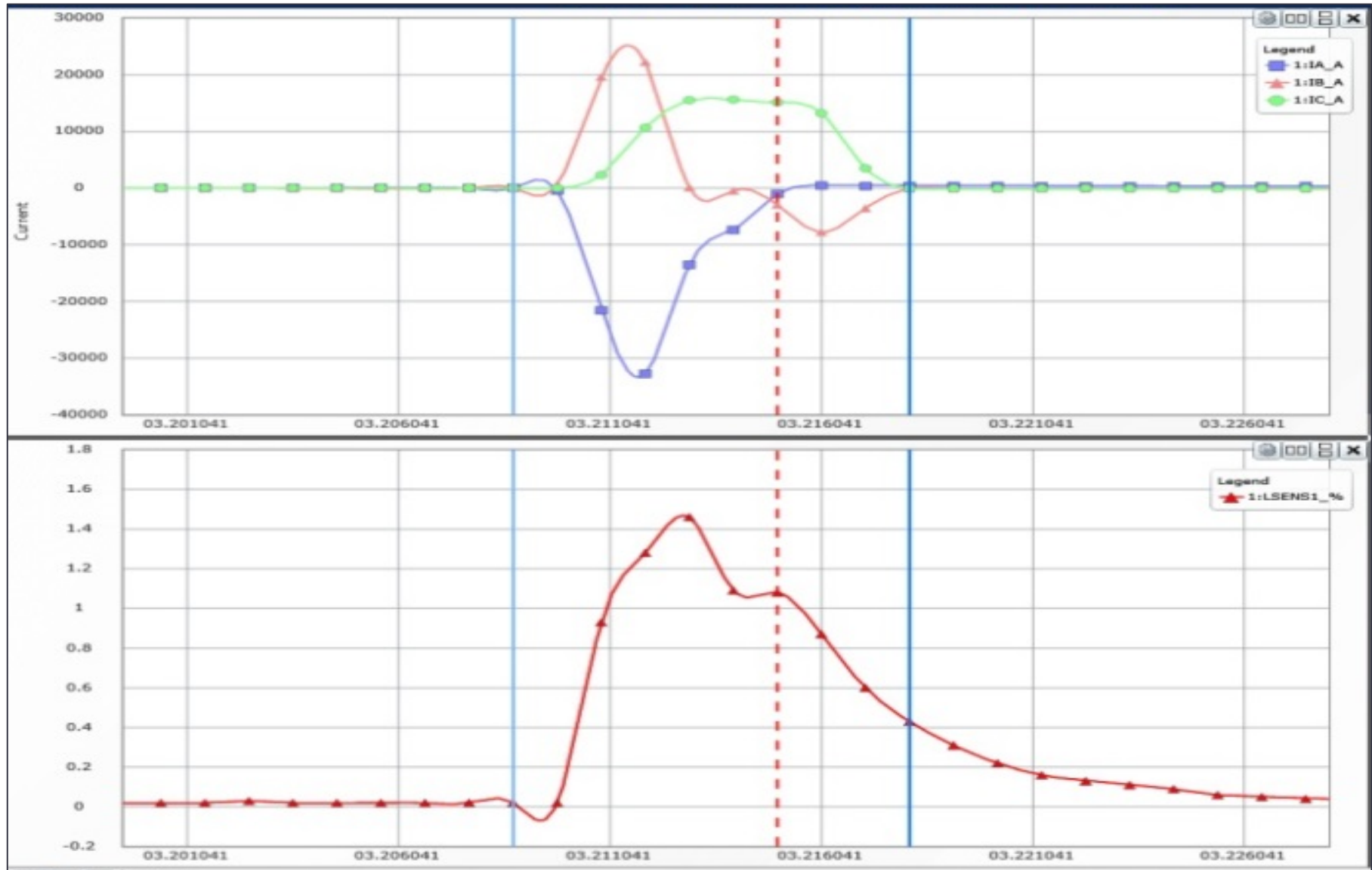

Results

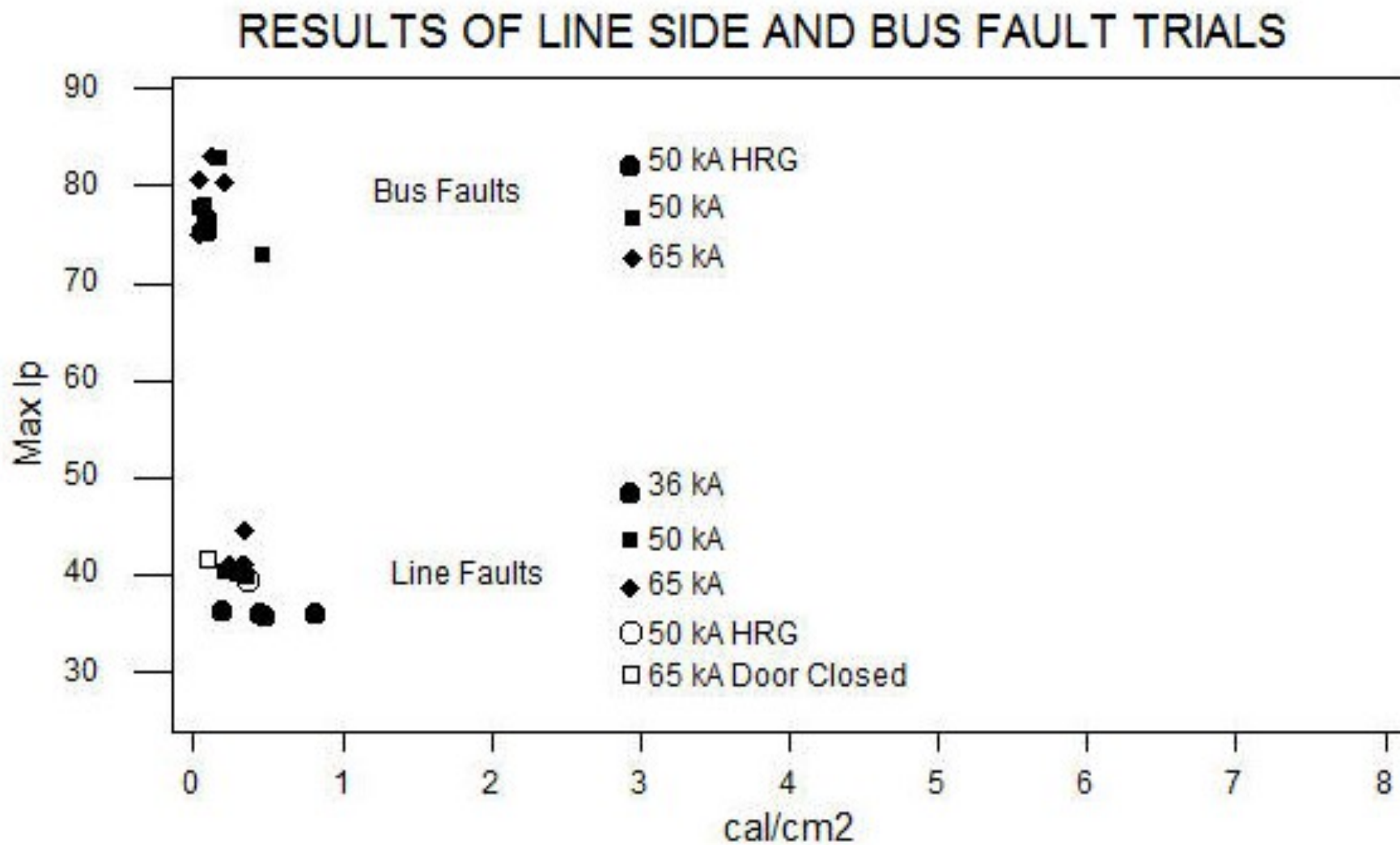

Summary

- These modifications cover typical open door troubleshooting activities done during normal operating conditions.
- They are supplemental to NFPA 70E and IEEE 1584 Arc Flash Requirements. LVMCC with these modifications will have supplemental labels indicating reduced PPE requirements.
- Tasks such as removing or inserting buckets should be done with PPE per IEEE 1584 Arc Flash Calculations.
- Modifications must be done with LVMCC de-energized.

OK, I want to do this...Now What??

- **Initial Site Survey**
 - Review test data with installed equipment
 - Determine if additional tests are required
 - Thermographic Inspection
 - Verification of Equipment type and arrangement
 - Scope of work
- **Program Planning**
 - Turnaround schedule
 - Installation Schedule
 - Procurement/Sub-Assembly
- **Installation**
 - Verification/Inspection Process
- **Post Installation Check**
 - Thermographic Inspection
 - Update Drawings to comply with NFPA 70E

Initial Site Survey

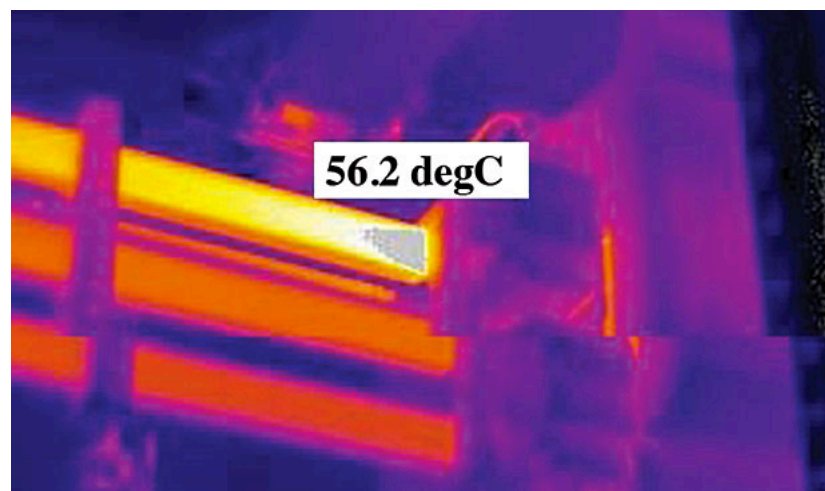
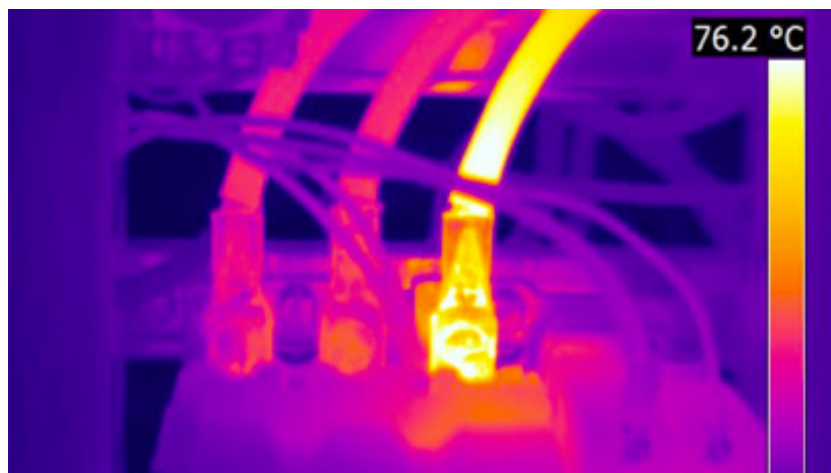

- Review of existing Arc Fault calculations
- Initial Thermographic Inspection
- One-Line Verification
- LV Switchgear details
- Installation Plan

- Determine if additional tests are required for performance verification

Initial Site Survey

- Buckets
 - Quantities by size
 - Review thermography

- Structures
 - Remove side panels
 - Install radius supports (x4)
 - Install light sensor loops
 - Install Junction box at each end for fiber connections

Program Planning

- Basics of Modification Program
 - Buckets
 - Removal of bucket
 - Remove existing Stab Assemblies
 - Add MCCB Breaker Cap and Tie Wrap
 - Install upgraded Stab Assemblies
 - Properly ground tinned copper leads
 - Insert, seal, and re-torque line leads to MCCB
 - Reinsert and connect buckets
 - Structures
 - Remove side panels
 - Install radius supports (x4)
 - Install light sensor loops
 - Install Junction box at each end for fiber connections

Program Planning

- Basics of Modification Program
 - Structures
 - Remove side panels
 - Install radius supports (x4)
 - Install light sensor loops
 - Insulate ends of horizontal busbars
 - Re-install side panels
 - Install junction box for fiber connections
 - Bus Duct (Optional)
 - Remove space heater access covers or splice plate covers (depends on configuration)
 - Install light sensor loops
 - Install junction box for fiber connections
 - Re-install covers

Program Planning

- Basics of Modification Program
 - LV Switchgear
 - Access rear compartment
 - Determine CT installation location
 - Review trip circuitry for trip input means from AFDR
 - Determine best location for mounting AFDR
 - Determine wiring requirements and fiber route(s)
 - Close rear compartments

THE END
