

Factory Equipment Testing of Single Lift Substation

Presented by: Kurt Vosburg & Ronak Goswami

IEEE CED – Houston Chapter
November 17-18, 2015

Objective

- This technical presentation will discuss various aspects of factory acceptance testing for the prefabricated electrical substation and its related SS system components (such as MV-LV Swgr, MV-LV MCC, UPS systems, AC/DC panels etc.) to assure the systems have been properly fabricated in strict accordance with design specifications.
- We will go through the various stages of project life cycle to discuss the procedures and safety considerations for a successful factory acceptance test (FAT).
- This presentation will emphasize the importance of detailed & structured FAT for a successful vertical plant start-up.

Understanding the prefabricated electrical substation



What is a Prefab building?

Custom engineered, prefabricated and fully integrated substation tailored to meet specific requirements of the electrical system package to reduce expediting and on-site civil construction costs.



Equipments inside the building:

Integrated Switchgear, Motor Control Centers, & other Associated Electrical & Control Equipment (i.e. VFD, UPS, Batteries, Instrumentation, etc.)

Understanding the prefabricated electrical substation



- Single and Multiple Split Configurations
- Designed for Concrete Slab or Elevated Piers
- Fully Integrated Electrical Equipment
- Readiness for future extension, floor cutouts
- Power and control interconnections

Understanding the prefabricated electrical substation



- Functional Test of Building Systems
 - Utilities
 - HVACs
 - Fire & Gas Detection / Suppression

- Integrated Inspection and FAT
 - MV/LV Switchgear
 - MV/LV MCC
 - UPS Systems
 - Battery Chargers
 - SS automation



Agenda

- Night 1:
 - Bid Clarification
 - Review RFQ package and all commercial/technical documents
 - Initiate estimating process & provide quote for the project
 - Kick Off Meeting
 - Define project members and their roles.
 - Project clarification and review documentation.
 - Safety precautions during electrical inspection
 - General precautions/checks that needs to be observed/made before & during testing of electrical equipment.
 - Understanding the manufacturing facility & equipment under test.

Agenda

- Night 1 (cont'd):
 - Equipment Internal Inspection
 - Getting equipment ready for the inspection.
 - Check equipment against all checklist and start with in-process inspection.
 - Start final inspection by performing various tests on the equipment (such as bussing check, control check, primary injection test etc.)
 - Make sure equipment is ready for the factory acceptance test.

Agenda

- Night 2:
 - Bid Clarification
 - Define project scope, schedule and timeframe for each phase of project.
 - Pre-FAT Meeting
 - Review inspection test plan (ITP) for each equipment type.
 - Define roles of each team member who is going to perform/witness the test.
 - Set an agenda illustrating the FAT schedule.

Agenda

- Night 2:
 - FAT Process (Test-Punch list-Retest)
 - Function Check
 - MV/LV MCC
 - MV/LV Switchgear
 - Annunciators
 - Fire Alarms
 - HVAC
 - Plant interlock scheme
 - Temporary power panel
 - Ship prep after FAT



Bid Clarification Process

The bid clarification process begins when a project issues a Request for Quotation (RFQ) which includes technical and commercial requirements.

- The technical information includes the details specifying the equipment details and fabrication specifications.
- The Sales Engineer/Estimating Engineer performs a detailed review of the project specifications/drawings and creates a costed bill of material and preliminary layout, which meets the requirements of the RFQ.
- Any exceptions to the technical specifications are identified and documented by the person estimating the job.

Bid Clarification Process

The preliminary design includes:

- Outline dimensional information for Pre-fab building/Equipment sizing.
- Estimated material & labor costs based on project's spec interpretation.
- Preliminary Bills of Material (BOM's) including Pre-fab building, buyout items, Switchgear, MCC's, Bus Duct, breakers and devices as per the project specifications.

Once quote proposal is submitted the process of bid evaluation & negotiations starts.

After successful bidding, purchase order or letter of intent (LOI) will be issued.

Kick Off Meeting

- Kick-off meetings are invaluable to disseminating information within the project environment. It is extremely important that correct and accurate information is processed and transferred from project to engineers.
- This is the opportunity for vendor to ensure that their interpretations are per project requirement & also an opportunity for customer to understand what they are really getting from the vendor.

Kick Off Meeting

- Project clarification
 - Ensure that all technical discrepancies and questions have been addressed prior to starting the design process.
 - Lesson learned from the past projects.
 - Discuss any unique fabricated or buyout items, alignment of vendor deviations or exceptions from the project requirements, or any long lead time items.

Kick Off Meeting

- Define project members and their roles
 - Review project organization chart and associated roles.
 - Discuss the tasks of different vendors associated with the project and the associated deliverables expected to be produced.

Each project participant should know their responsibility and understand the issues that may impact the successful completion of the project.

Kick Off Meeting

Project Organization Chart

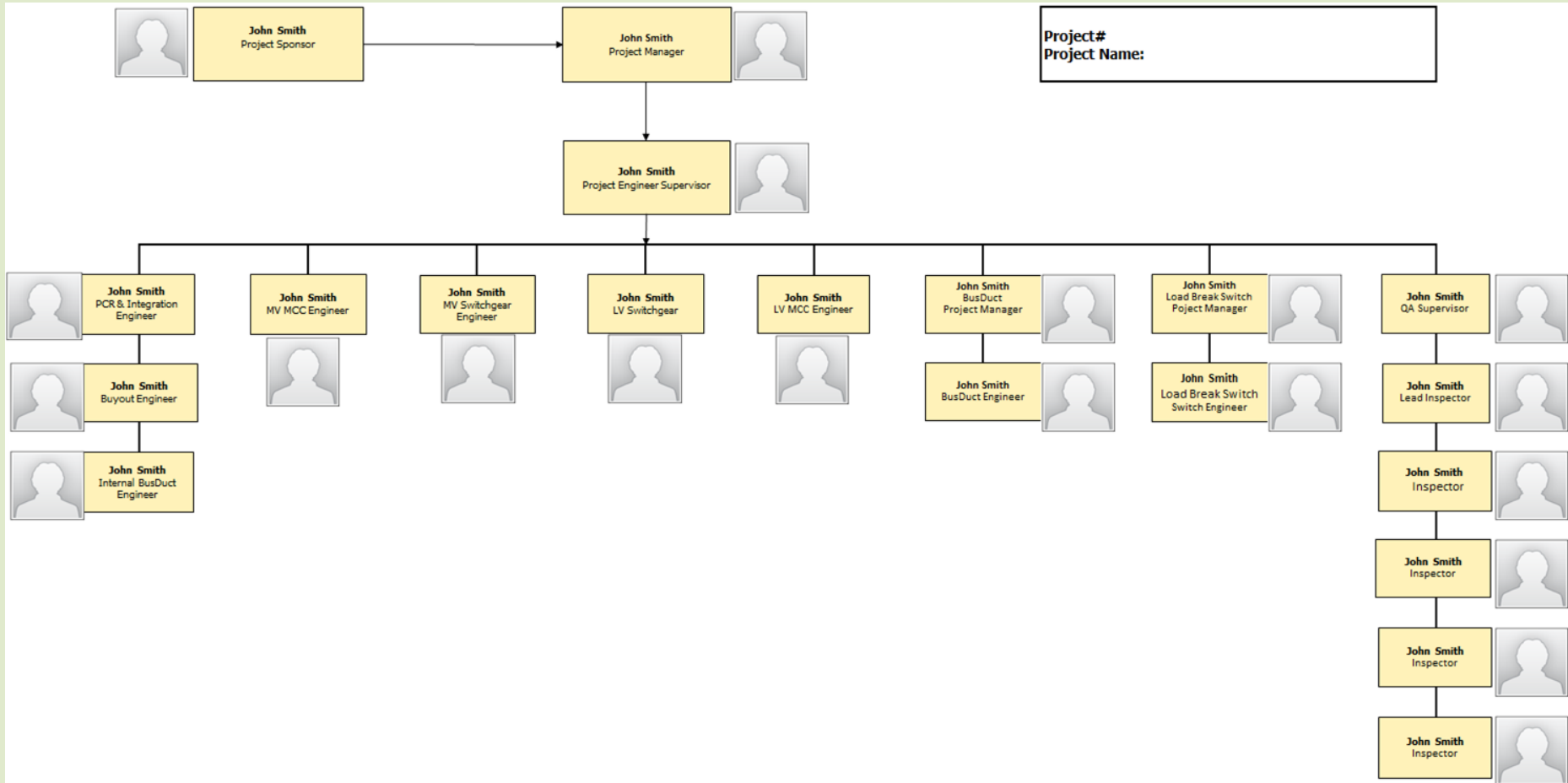

Kick Off Meeting

Equipment List

No.	Equipment Tag No.	Equipment Name	Dimensions (L x W x H)	S/L DWG.	Brief Description / Remarks
1	SUB-123	Prefabricated Substation	24' x 60' x 12'	N/A	Including access platforms (stairways, landings, steel ladders), raceways/cable trays, lighting, receptacles, photocelles, switches, HVAC system, fire precautions, grounding, lightning protection, etc. required for completion of the package.
2	SWGR1/123	4.16kV Switchgear/Controlgear		SUB 123-01110	
3	MCC1/123	4.16kV Motor Control Center		SUB 123-01111	
4	SWGR2/123	480V Switchgear		SUB 123-01210	Including High Resistance Grounding (HRG)
5	BD1/123	4.16kV Busduct		SUB 123-01110	
6	BD1/123	480V Busduct		SUB 123-01210	
7	MCC2/123	480V Motor Control Center		SUB 123-01310	
8	MCC3/123	480V Motor Control Center		SUB 123-01123	
9	UPS2/123	125V DC Battery Charger		SUB 123-01510	
10	BAT2/123	125V DC Battery Rack		SUB 123-01510	
11	SW2/123	125V DC Battery Disconnect Switch		SUB 123-01510	
12	UPS1/123	120V AC UPS 60KVA		SUB 123-01520	
13	BAT1/123	120V AC UPS Battery Rack		SUB 123-01520	
14	SW1/123	120V AC UPS Battery Breaker Switch		SUB 123-01520	
15	ANN/123	Annunciator Panel		N/A	
16	LP1/123	3BSS123 Lighting and Receptacle Panel		N/A	Including Transformer
17	LCP/123	3BSS123 DC Lighting Control Panel		N/A	
18	AP1/123	3BSS123 HVAC Panel		N/A	
19	FAP/123	3BSS123 Fire Alarm Control Panel		N/A	

Kick Off Meeting

- Review QA/QC procedures & forms
 - Discuss test description, method of test & responsible party for each equipment type.
 - Define customer inspection policy and specify if additional tests are required.
- Capture meeting minutes
 - Document major discussion points, resolutions, action items and the corresponding team member responsible for those actions.

What happens next?

- Engineering Design
- Building Construction
- Equipment Assembly
- Equipment Installation

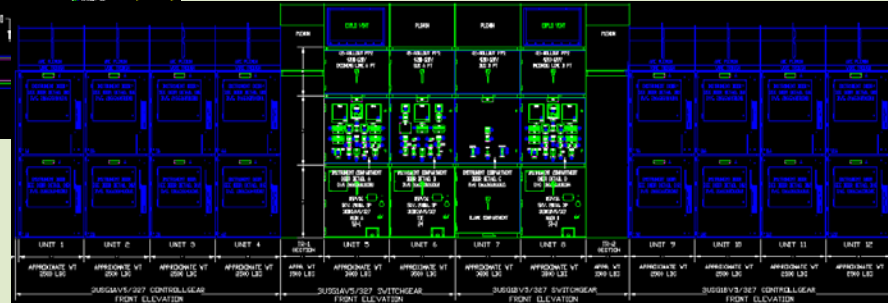
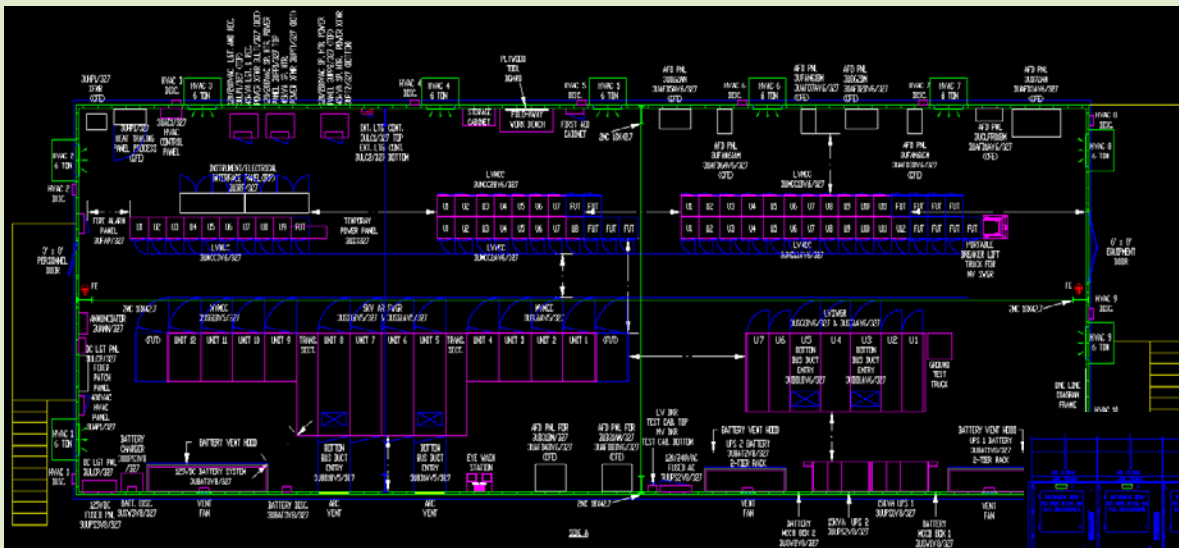

What happens next?

- Engineering Design
- **Equipment Assembly**
- Building Construction
- Equipment Installation



What happens next?

- Engineering Design
- **Building Construction**
- Equipment Assembly
- Equipment Installation



What happens next?

- Engineering Design
- Building Construction
- Equipment Assembly
- **Equipment Installation**



Finish Production



Safety precautions during electrical inspection

- PPE for electrical inspection:
 - *Safety Glasses*: to be used when circuit bridging (jumpering)
 - *Touchless AC voltage indicator*: to detect the presence of AC voltage
 - *Lock out device*: for electrical lockout/tagout
 - *Hasp*: for electrical lockout/tagout
 - *Personal lock & tag*: for electrical lockout/tagout

Safety precautions during electrical inspection

- **General safety precautions/checks:**
 - Do not wear conductive article of jewelry and clothing.





Safety precautions during electrical inspection

- **General safety precautions/checks (cont'd):**
 - Always use test equipment that is in good working order and in safe condition.
 - Always assume all conductors are “HOT” until verified to be de-energized.
 - A ground wire must be attached to all equipment under test and to all test equipment prior to energizing.
 - Get acquainted with the equipment to be tested prior to energization.



Safety precautions during electrical inspection

- **General safety precautions/checks (cont'd):**
 - When using wall or floor junction boxes, the power cable should be secured to the box to prevent the cable from being unplugged.
 - Arrange power cords or other types of extension cords such that it prevents a trip hazard.
 - Always turn off test equipment and disconnect from the source before disconnecting it from the job.



Safety precautions during electrical inspection

- **General safety precautions/checks (cont'd):**
 - PT and CPT primary circuit fuses must be removed when running secondary voltage unless the primary is energized with bus wires removed from the fuse block.
 - Power factor correction capacitors and surge arrestor should not be energized.
 - Never use alligator clips to attach high voltage test carts leads to the bus bar.

Safety precautions during electrical inspection

- Define the boundaries that prohibit unauthorized personnel from entering the restricted area.



Safety precautions during electrical inspection

- Use warning lights on the test equipment to warn area personnel of presence of voltage on the equipment.



Safety precautions during electrical inspection

- Limit the use of high voltage as much as possible. Ensure that all high voltage test leads are color coded and readily identifiable. “A” phase is black, “B” phase is red and “C” phase is yellow.



Safety precautions during electrical inspection

Special precautions should be observed with following:

Device	Potential Danger	Required Action
Circuit Breakers	Stored Energy	<ul style="list-style-type: none">• Make sure springs are discharged & contacts are open before attempting any service.
Current Transformers	Shock Hazard & Equipment Damage	<ul style="list-style-type: none">• Do not open secondary of any CT under load.• Before disconnecting any CT leads, remove power source or short the secondary at shorting type TB.
Capacitor Trip Device	Shock Hazard & Electrical Burns	<ul style="list-style-type: none">• Removing the device cover automatically discharges some cap trip devices.• Shorting output with resistor can also be used to discharge cap trip device.



Safety precautions during electrical inspection

- Customer Inspection Safety:

CUSTOMER INSPECTION SAFETY REVIEW

Sales Order No.: _____

Lead Inspector: _____

1. I have been made aware of the hazards associated with testing this equipment.
2. I have been made aware of the voltages that will be present during this inspection.
3. I have been made aware of the significance of inspection tapes, barriers, lights and signage being used on this equipment.
4. I have been made aware of the physical obstacles and hazards associated with this equipment.
5. I will always ask a Powell Inspector to turn on any switches and breakers.
6. I will never touch any bus work, T leads or circuits unless a Powell Inspector verifies that it is de-energized.
7. I will always ask a Powell Inspector before operating, changing positions, or removing devices.
8. Remember that many devices utilize stored energy, both electrical and mechanical. Never put your hands inside a device without first asking a Powell Inspector.
9. Remember that the energization status of equipment may change many times during the course of the inspection. Never assume that a circuit is de-energized. Always check with a Powell Inspector before touching the equipment.



Safety precautions during electrical inspection

Conclusion:

- Familiarize yourself with manufacturing facility & equipment under test.
- Only the authorized personnel is responsible for the handling of the power handle.
- Read manufacturer's instruction bulletin prior to any testing.
- Do not look for shortcuts.
- Do not put yourself in a position where you feel your safety has been compromised.

Equipment Internal Inspection

Objective: To thoroughly inspect the equipment utilizing internal checklists and procedures to ensure that the equipment have been properly designed and constructed to meet the specifications.



Equipment Internal Inspection

Process Flow

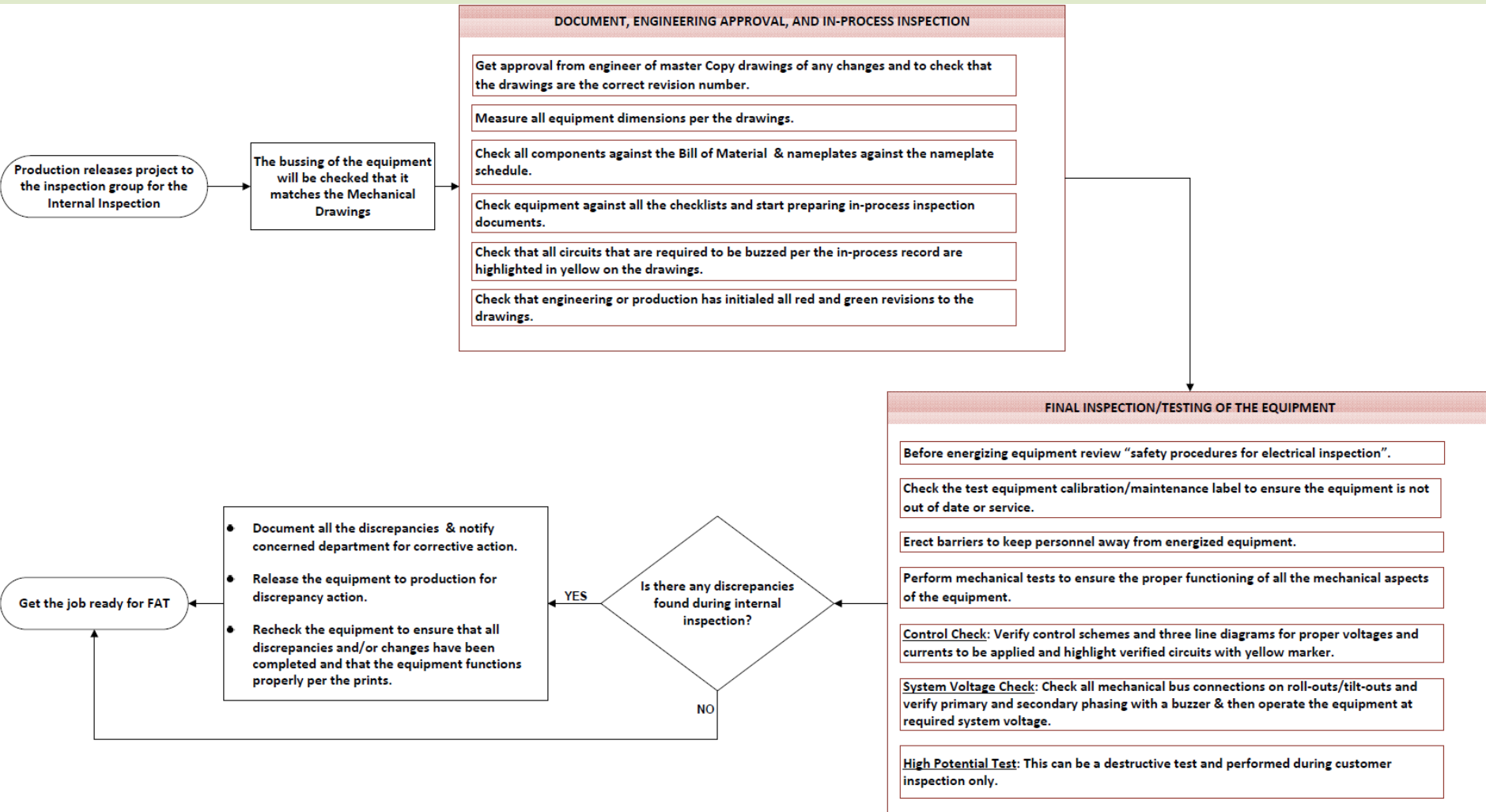

Equipment Internal Inspection

Equipment Line History Checklist:

EQUIPMENT LINE HISTORY CHECKLIST – PVAR		
Check	YES	N/A
Verify that you are using the latest revision of this form by checking the Master List of Controlled Documents.		
W.O.#		
1. MECHANICAL TESTS AND CHECKS		
1.1 Mechanical Operations Tests		
A. Circuit Breaker Checks		
a. Test position, check that the circuit breaker cannot be racked in when closed.		
b. Check that circuit breaker trips free at any position between test and connected.		
c. Check that circuit breaker cannot be racked in or out with door open unless interlock is defeated.		
d. Check that the closed door racking interlock operates correctly		
e. Check the racking position indicators for proper alignment		
f. Check racking in pressure for excessive force. On all ½" copper breakers if breakers are difficult to rack in, rack breakers in and out five times, remove from cell, grease stabs and rack in and out until breaker racks in smoothly.		
g. Check that the circuit breaker front cover does not hit terminal blocks, relays, fuse blocks, etc, when racking.		
h. Check that TOC operates correctly		
i. Close the circuit breaker.		
j. Check that MOC operates correctly.		
k. Check that secondary disconnect cannot be pulled out when circuit breaker is racked to connected position.		
l. Connected position, check that circuit breaker cannot be racked out when closed.		
m. Check that push to trip operates correctly.		
n. Check each unit that the rear door interlock prevents you from opening the rear door when the breaker in that unit is racked in.		
o. Rack circuit breaker to disconnected position.		
p. Check each unit with rear door interlock that the door can be opened with the circuit breaker racked out.		
q. Check that all springs discharge when circuit breaker umbilical cord is removed from breaker.		
r. Repeat for all circuit breakers and cells.		
B. Assembly, Cells, Doors, Cover Plates, and Barrier Checks		
a. Check the dimensions on elevation, base plan and sectional view drawings against the switchgear.		
b. Check three-line diagram against each unit for correct polarity and size of current transformers.		
c. Check that shutter assembly opens completely with breaker in, and closes with breaker out		
d. Check that shutter position indicator operates correctly.		
e. Check that tack welds have not warped the breaker pan to prevent damage to the breaker trip rod.		
f. Check each unit for correct hardware and for tightness		
g. Check that barriers and cover plates are installed and fit correctly.		
h. Check that doorstops prevent damage to relays or if they are required.		
i. Check that door alignment guides have been installed and are working correctly.		

Equipment Internal Inspection

Equipment Line History Checklist:

EQUIPMENT LINE HISTORY CHECKLIST – PVAR		
Check	YES	N/A
C. Key Interlocks		
a. Check that each key interlock assembly and the entire key interlock system operates correctly.		
b. Record key interlock key numbers on key interlock schedule.		
D. Bus Work		
a. Check the three-line and sectional view drawings against the switchgear bus work.		
b. Check bus location and size of bus against original job prints if switchgear is adding on to an existing job.		
c. Check all bus clearances.		
d. Check that no silicon bronze hardware has been mixed with stainless or plated steel hardware.		
e. Check all bus boots for proper fit and application, no gaps.		
f. Check that bus dimensions and phasing will line up to transformer or mating equipment drawings.		
g. Check with engineering that the voltage rating of lightning arrestors is correct for the system voltage of the equipment.		
h. Check that ground bus connections have been made between units and to mating equipment.		
i. Check that bus duct has been fitted to equipment and pictures taken.		
j. Check that splice plates or flex connectors for bus duct, xfmr, and etc. connections have been provided.		
j. Check with engineering that there is adequate room for terminating cables in tight locations.		
k. Check that the first 2-3 inches of the high voltage cable are not in contact with ground or another phase conductor and that the strands are not nicked or cut.		
l. Check that customer cables will fit through ground fault CT.		
m. If equipment is matching to customer equipment in field, (MV MCC, HV Switch, transformer, etc.) question sales on the EDR if we are to provide bus splice material, bus hardware, and assembly hardware.		
E. Roll Out Transformer Compartments		
a. Check that all PT/CPT/Fuse Rollouts roll in and out smoothly.		
b. Check all rollout stabs for proper alignment, tightness, and that the entire curved surface touches the stationary stab.		
c. Check rollout secondary is grounded when the unit is pulled out or opened.		
d. Check that CPT rollout is interlocked with CPT secondary circuit breaker		
e. Check PT/CPT/Fuse Rollout primary fuse clips for tightness.		
f. PT and CPT fuses checked with ohmmeter before and after testing.		
g. Check rollouts for bus or cable per three-line diagram.		
h. Check three-line diagram against equipment for proper placement of PT's and CPT's.		
i. Check with buzzer that the primary phasing of all PT and CPT connections is per the three-line diagram.		
j. Check rollout primary phasing are labeled per three-line diagram.		
k. Check potential transformers with ohmmeter for proper location of primary windings.		
l. Check that Neutral ground resistor for HRG has not been mounted above breaker.		

Equipment Internal Inspection

Equipment Line History Checklist:

EQUIPMENT LINE HISTORY CHECKLIST – PVAR		
Check	YES	N/A
F. Wiring		
a. Check with buzzer that the secondary wiring of all PT and CPT connections is per the three-line diagram.		
b. Check with buzzer that the secondary wiring of all current transformers is per the three-line diagram.		
c. Check that closely spaced terminals have insulated lugs or heat shrink installed		
d. Check test switches for correct wiring and/or jumpers		
e. Check that space heaters do not interfere with conduit or cable entrance		
f. Check that mimic bus dimensions are AS-BUILT for future extension of equipment		
G. Accessories		
a. Test cabinet checked and tested with breakers on job.		
b. Breaker lift truck for switchgear, check that unit has no loose hardware and use with job.		
c. Electric rack in device checked in each unit.		
1.2. Interchangeability Tests and Checks		
a. All breakers of the same rating checked for interchangeability into same rating cells		
b. Breakers of different ratings checked – Higher rating breaker will go into lower rating breaker cell but lower rating breaker will not go into higher rating cell.		
2. ELECTRICAL TESTS & CHECKS		
a. Check each circuit breaker part number against the bill of material.		
b. Check three line that all "67" and "87" relay circuits are connected per the manufacturer's bulletin		
c. "67" and "87" relay circuits that cannot be tested, buzz out entire circuit per three line and manufacturer's bulletin		
d. Check that differential relay circuits are grounded in one place only		
e. Check with engineering when line and load side of equipment is not identified on three line diagram		
f. Pull and insert each PT Roll-Out while main buss is energized with system voltage. Listen for noise		
g. Pull and insert each fuse Rollout while main buss is energized with system voltage. Check that CPT secondary breaker is open or that all loads have been denergized		
h. Rack circuit breakers in and out while main buss is energized with system voltage		
i. Check under voltage schemes for both momentary dip and sustained loss of voltage		
j. Check location of UV relays on three-line for main-tie-main control schemes		
k. Check phase relationships on all power relays, meters, and transducers		
l. Check all with engineering on all components on 50 Hz jobs not marked for 50 Hz operation on nameplate		
m. Check all Current Test switches that before shorting blade disengages from jaw that bottom cam on blade are making contact with shorting spring.		
n. On relays with ground fault check that the current transformer ratio and relay input are correct, 1 amp versus 5 amp input.		

Equipment Internal Inspection

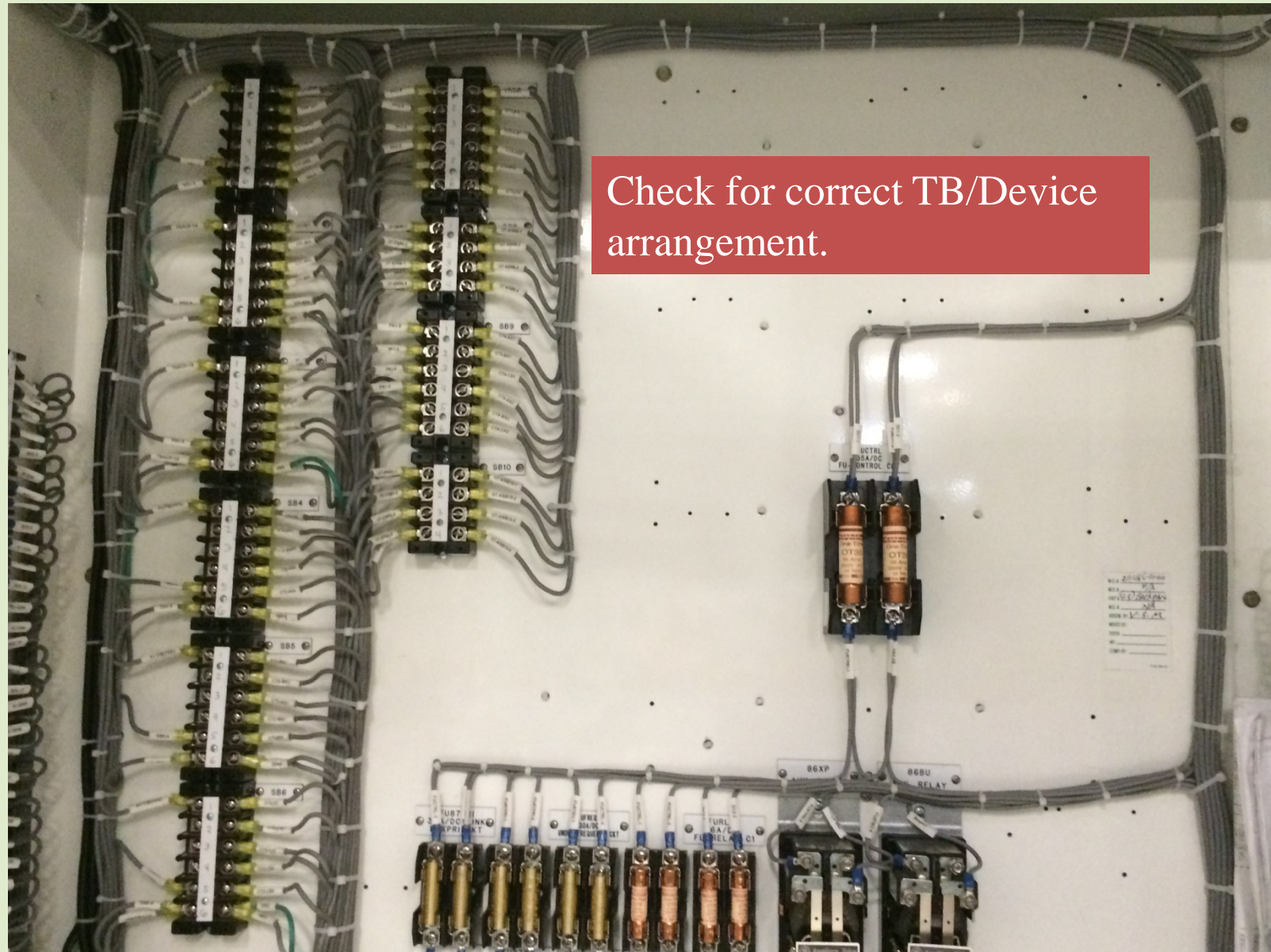

Check for correct TB/Device arrangement.

Equipment Internal Inspection

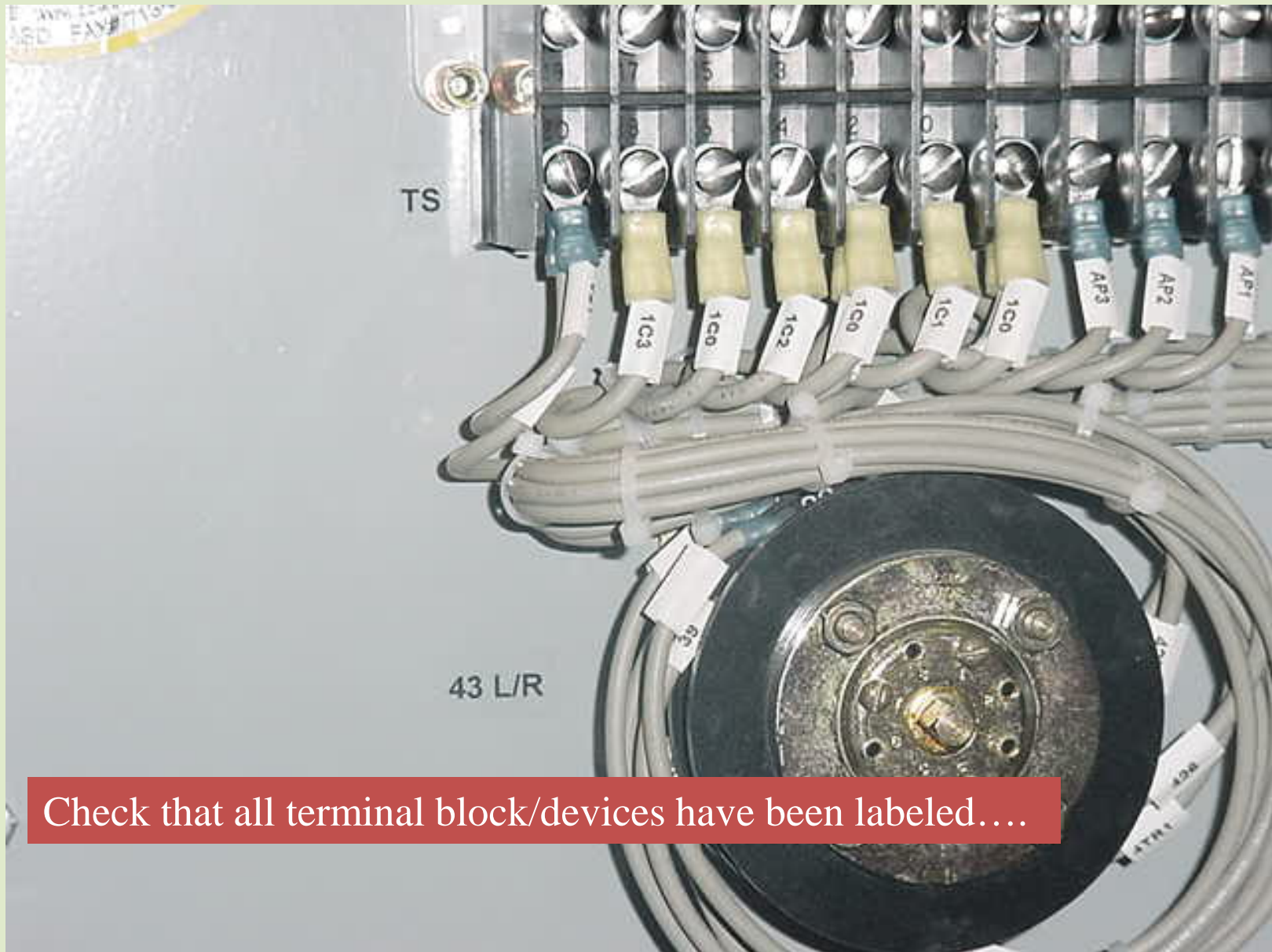

Check that all terminal block/devices have been labeled....

Equipment Internal Inspection

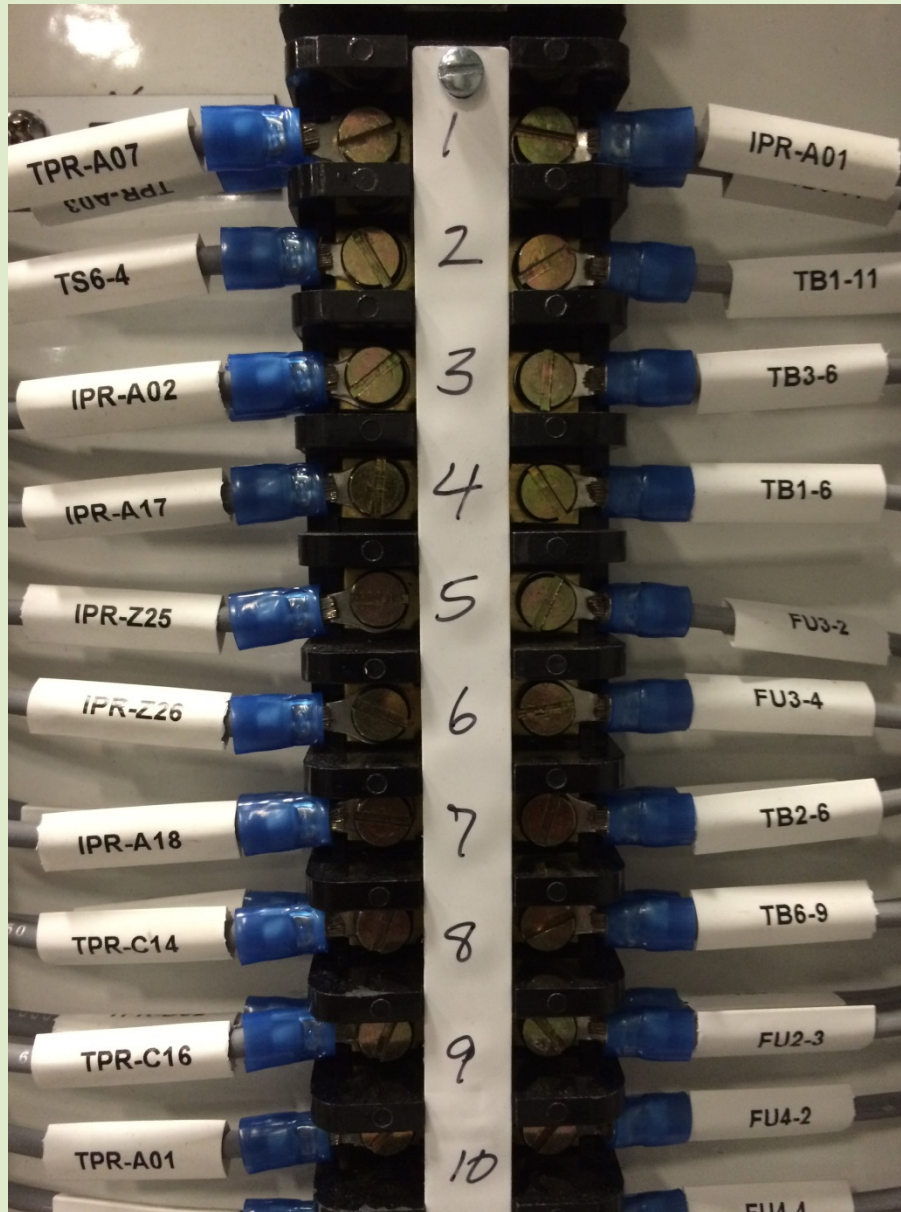

....Check that TB markings are legible.

Equipment Internal Inspection

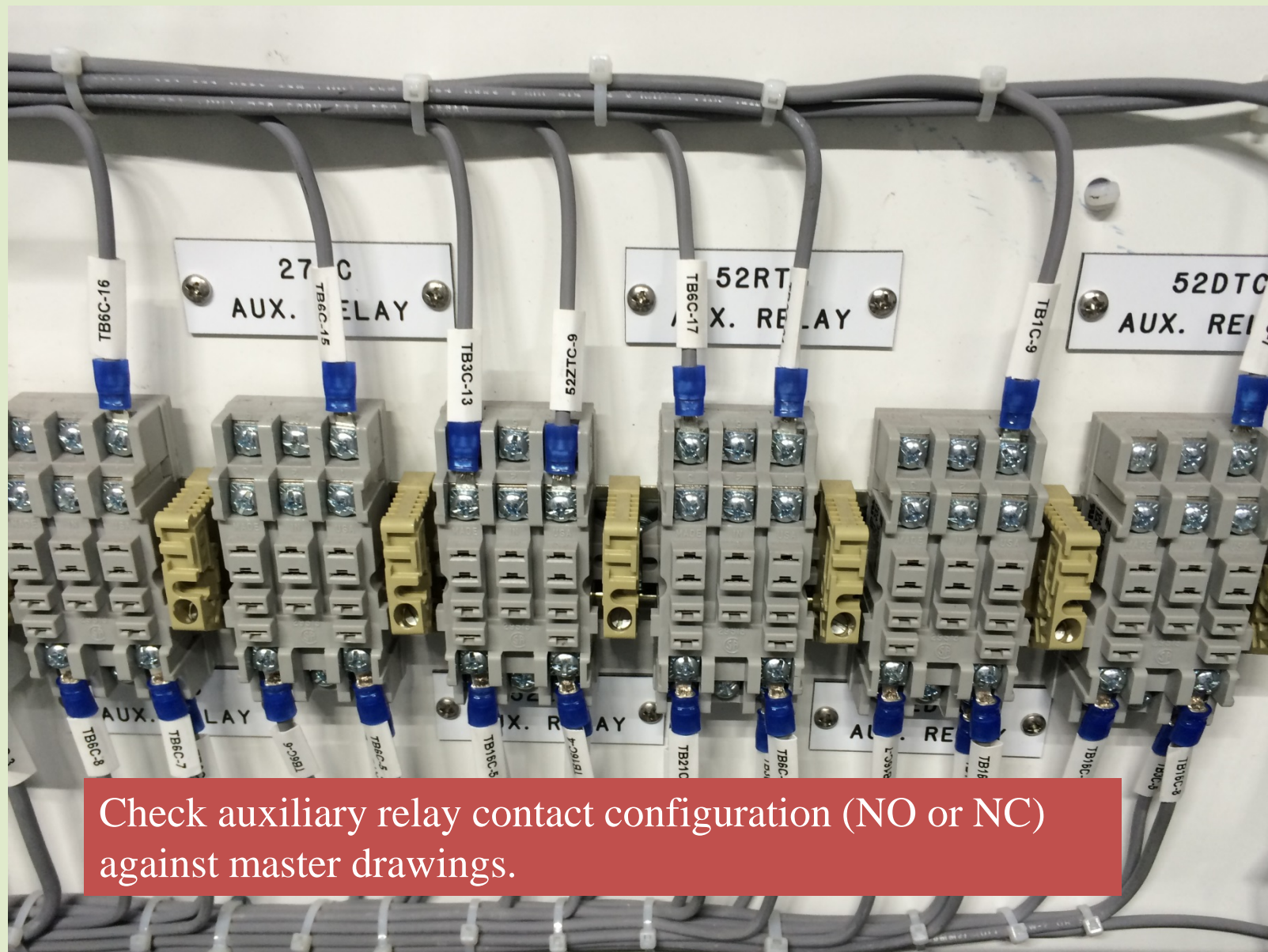

Check auxiliary relay contact configuration (NO or NC) against master drawings.

Equipment Internal Inspection



- Check that correct fuses or links have been installed.
- Check that the TOC has been installed and adjusted.

Equipment Internal Inspection

Check that MOC has been installed and adjusted.



Equipment Internal Inspection

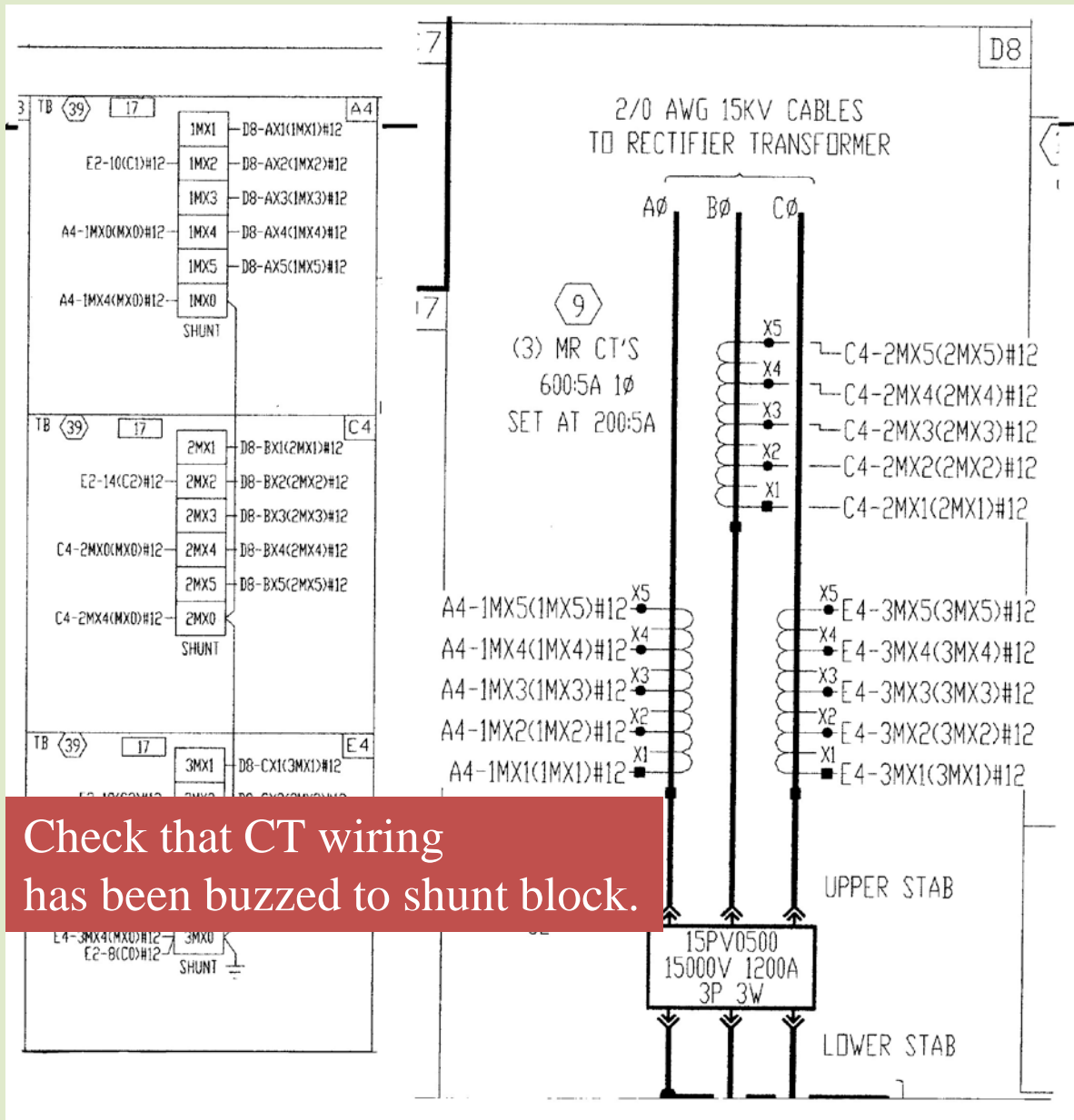

Check that CT wiring has been buzzed to shunt block.

Equipment Internal Inspection

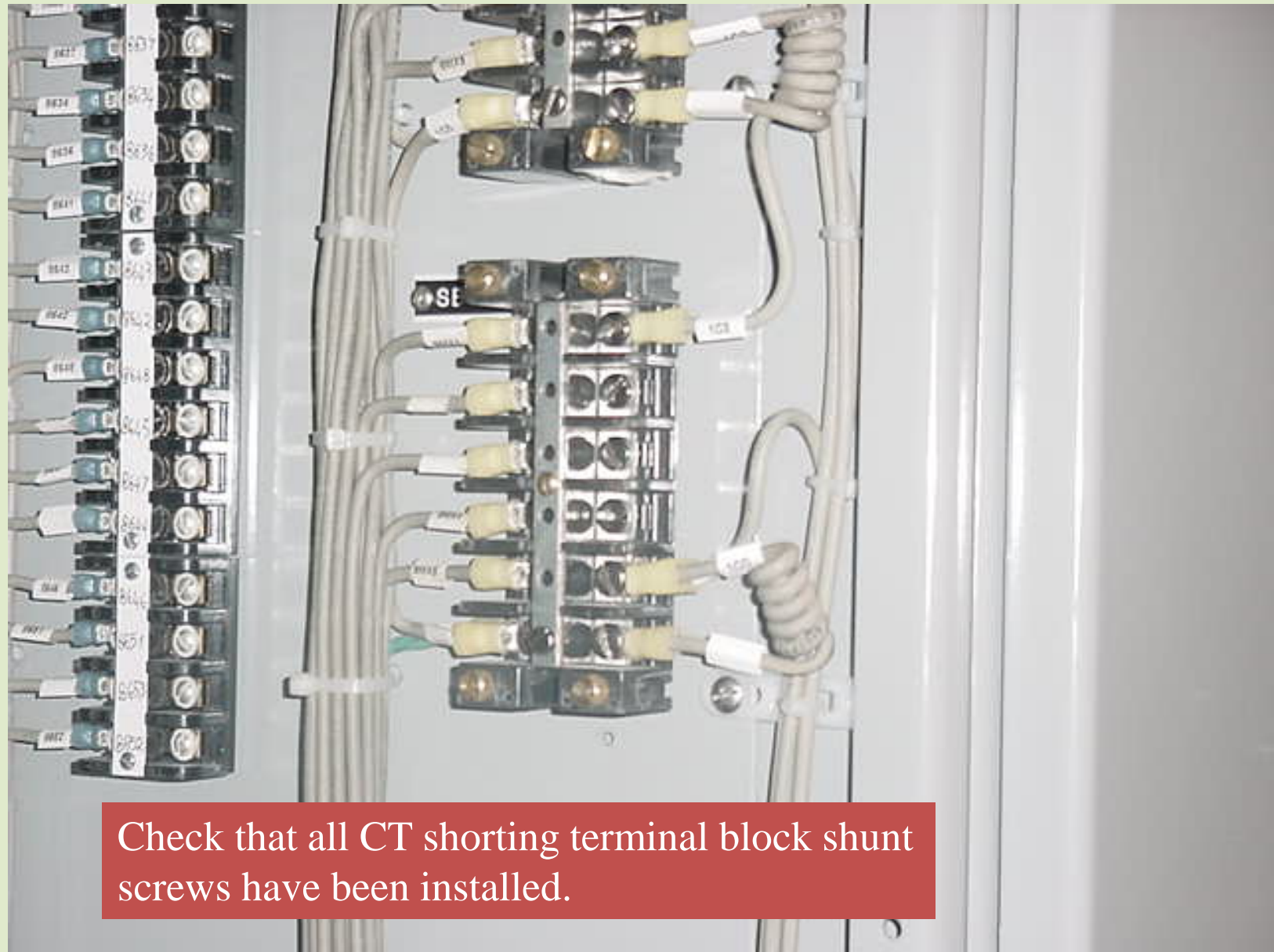

Check that all CT shunting terminal block shunt screws have been installed.

Equipment Internal Inspection

Buzz all PT, CPT, & DC wiring to fuse blocks or circuit breakers.

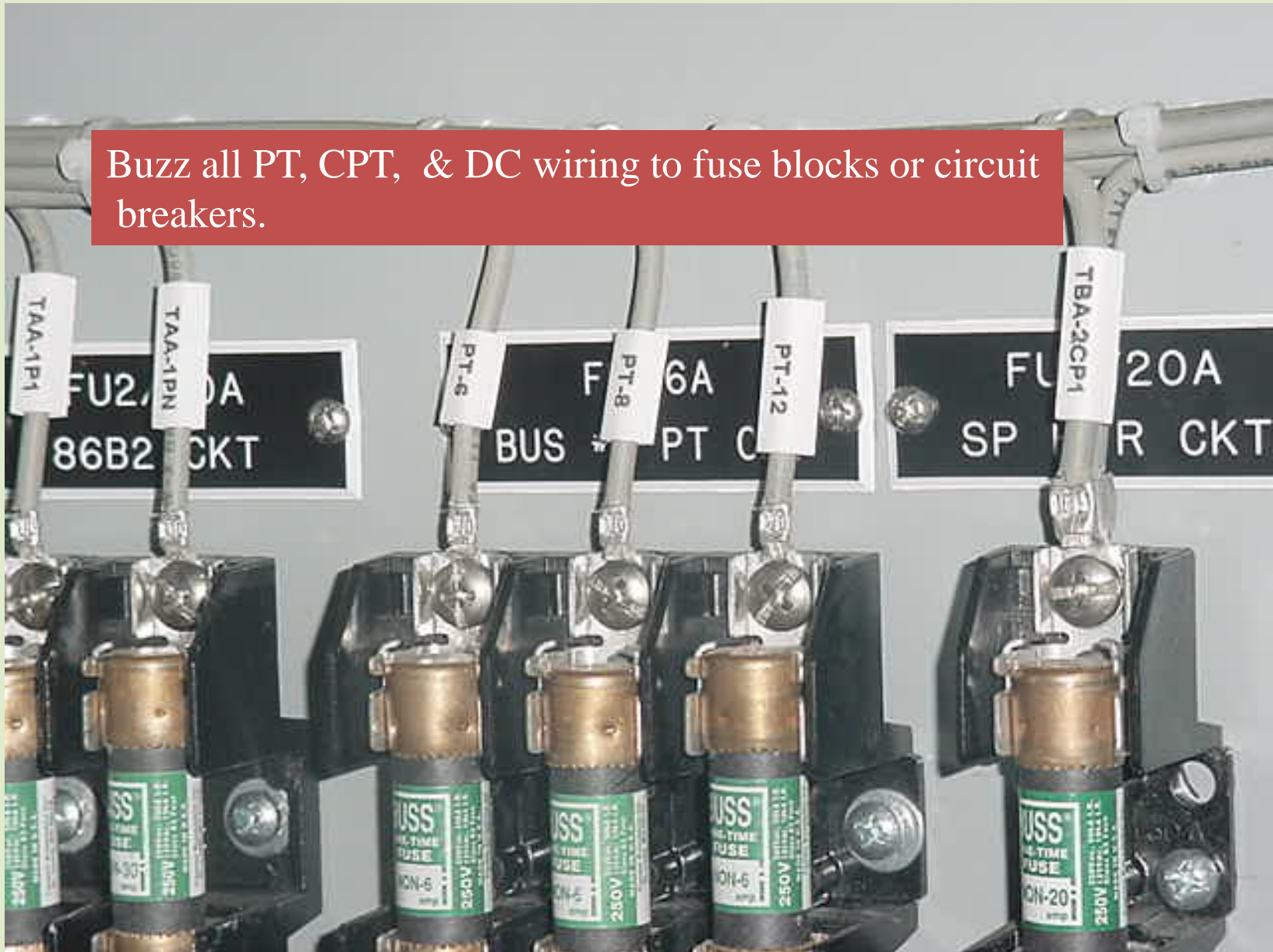

Equipment Internal Inspection

POWVAC-AR 5/15KV SWITCHGEAR SPECIFICATIONS

I. Equipment Classification

Metal-Clad Arc Resistant Switchgear (per ANSI/IEEE C37.20.7)
 system voltage 24KV BIL kV 60 95
 phase 3
 wire 3
 frequency Hz 50 60

System Grounding type:
 Solidly grounded
 Low resistance grounded
 High resistance grounded
 Ungrounded

Max. Ambient Temperature Is 40°C at 3300' elevation or below.
 Other: * (de-rating of equipment may apply)

II. Construction & Finish

A. STANDARD CONSTRUCTION REQUIREMENTS

- Enclosure to be constructed of:
 - 11 gauge steel
- Enclosure to be:
 - AR Type 1
 - AR Type 2B
- Front & back Equipment accessibility.
 - 4. Channel base:
 - Shipping purpose only
 - Permanent on equipment
 - Not required
 - (Note: Recommended leveling channels to be furnished and installed by others.)
 - 5. Equipment dimensions:

total overall height	<u>118 13/8</u>
total overall width	<u>864 (432 X 2)</u>
total overall depth	<u>104</u>
max. shipping sect. dim. (HxWxD)	<u>*</u>
<input checked="" type="checkbox"/> Shipped inside PCR W.D. #	<u>*</u>
6. Nameplates (See NP schedule for size and color) (unless specified, adhesive labels to be provided for all devices, including back of front door)
 - On front door
 - Not required

B. SPECIAL CONSTRUCTION REQUIREMENTS

- Special exterior paint color: * Other
 - AR top barriers / plenum
 - AR plenum integral to switchgear
 - AR plenum integral to PCR
 - AR rear door interlocks
 - Gasketed bottom-entry cover plates:
 - Power cable entry
 - Control cable entry
 - UL label
 - Nameplates: Interior Devices Back of Front door
 - IR windows (bulkhead with D-410 label req. on AR doors)
 - Plenum barrier at tie breakers to isolate Bus 1 & Bus 2
- SHUTTERS SHALL BE CLEARLY MARKED WITH FOLLOWING INSCRIPTION INDICATING (1/2" HIGH WHITE LETTER WITH RED BACK GROUND), 3"x5" NAMEPLATE SIZE
 MAIN BREAKER: "CONNECTED TO INCOMING"
 FEEDER BREAKER: "CONNECTED TO OUTGOING"
 TIE BREAKER: "CONNECTED TO BUS SIDE"

III. Bussing

A. STANDARD BUSSING REQUIREMENTS

- Main bus current ratings (Amps - Bar size/phase)
 - 1200A - (1) 1/4 x 4 2000A - (1) 1/2 x 6
 - 3000A - (2) 1/2 x 6 4000A - (2) 5/8 x 6
- Ground bus (1) 1/4 x 2, tin-plated
 - PCR floor PCR loop and lug size 4/0
- Main bus voltage rating kV: 4.76 15
- Bus bracing kA (rms sym):
 - 25 (5kV option) 36 50
- Bus arrangement:
 - Standard bus arrangement A-B-C (=1-2-3) left to right, front to back, top to bottom.
7. Bus insulation:
 - FLUIDIZED BED - Epoxy
8. Equipment incoming services:
 - top cable bus
 - bottom cable bus
9. Feeder exit:
 - top cable bus
 - bottom cable bus

B. SPECIAL BUSSING REQUIREMENTS

- Tin plated copper main bus Other
 - EPOXY - HI-PDXY 2000 bus insulation
 - Cycloaliphatic Epoxy standoff insulators
 - Porcelain standoff insulators
 - Stainless Steel hardware
 - Silicon Bronze hardware
 - Belleville washers
 - Special bus arrangement: *
 - Ground bus plating matches main bus
 - Main bus support to be sheet glastic with cycloaliphatic epoxy inserts (5kV option)
 - Main bus support to be sheet glastic with porcelain inserts (5kV option)
- CABLE SUPPORT SHALL BE LOCATED 6 INCHES FROM THE ENTRY AND 18 INCHES FROM THE CONNECTION POINTS.
 - THE DISTANCE FROM THE CABLE ENTRY POINT TO THE TERMINATION LOCATION SHALL BE 36 INCHES OR GREATER.
 - CONNECTIONS OF PRIMARIES OF VT'S FROM THE MAIN BUS SHALL BE THROUGH INSULATED COPPER BUS.
 - CABLE TERMINATION SHALL BE PLATED AND SUITABLE FOR 4-NEMA 2 HOLE CONNECTION

IV. Wiring

A. STANDARD WIRING REQUIREMENTS

- Wiring:

	wire gauge	wire type	wire color/code	lug type	lug insul.
Control circuits	14	SIS (VV-1)	GRAY	LOCKING FORK	YES
Potential circuits	14	SIS (VV-1)	GRAY	LOCKING FORK	YES
Current circuits	10	SIS (VV-1)	BLACK	RING	YES
Control power bus	8	SIS (VV-1)	GRAY	SEAMLESS RING	YES
Space heater circuits	14	SIS (VV-1)	GRAY	LOCKING FORK	YES
506A GSCT	10	SIS (VV-1)	BLACK	RING	YES
Analog/digital outputs	16	SHIELDED	SEE DWG.	LOCKING FORK	YES
Communications	22	SHIELDED	SEE DWG.	NONE	N/A

(When special color-coding is required on wiring larger than #10 awg, colored tape shall be used on both ends of each wire. See Wiring Dia.)
- Space heaters:
 - Required

watts	<u>125W/500W</u>
volts	<u>120V/240V</u>
oper. volts	<u>120VAC</u>
 - Not required
 - Thermostat per line-up
 - Thermostat per unit
- Control cable entry:
 - Top
 - Bottom
 - Top and bottom
- Terminal Blocks:
 - Control TB type: EB-25
 - Shorting TB type: EB -27

B. SPECIAL WIRING REQUIREMENTS

- Destination type wiring
 - Humidistat for space heater ckt.
 - 20% spare terminal blocks.
 - High/Destination type wiring
 - Other
- WIRING THAT CROSSES HINGED DOORS OR PANELS SHALL BE EXTRA FLEXIBLE TYPE WITH 37 OR MORE STRANDS
 - WIRE BUNDLES SHALL BE ARRANGED IN A SPIRAL CONFIGURATION SO THAT THE BUNDLE TWISTS RATHER THAN BENDS WHEN DOOR IS OPENED.
 - ALL GROUNDING CONDUCTORS SHALL BE MADE WITH GREEN INSULATED WIRE.

Check that equipment is in compliance with the Master Copy specification print.

Equipment Internal Inspection



Check Bill of Material against equipment and master drawings

Equipment Internal Inspection

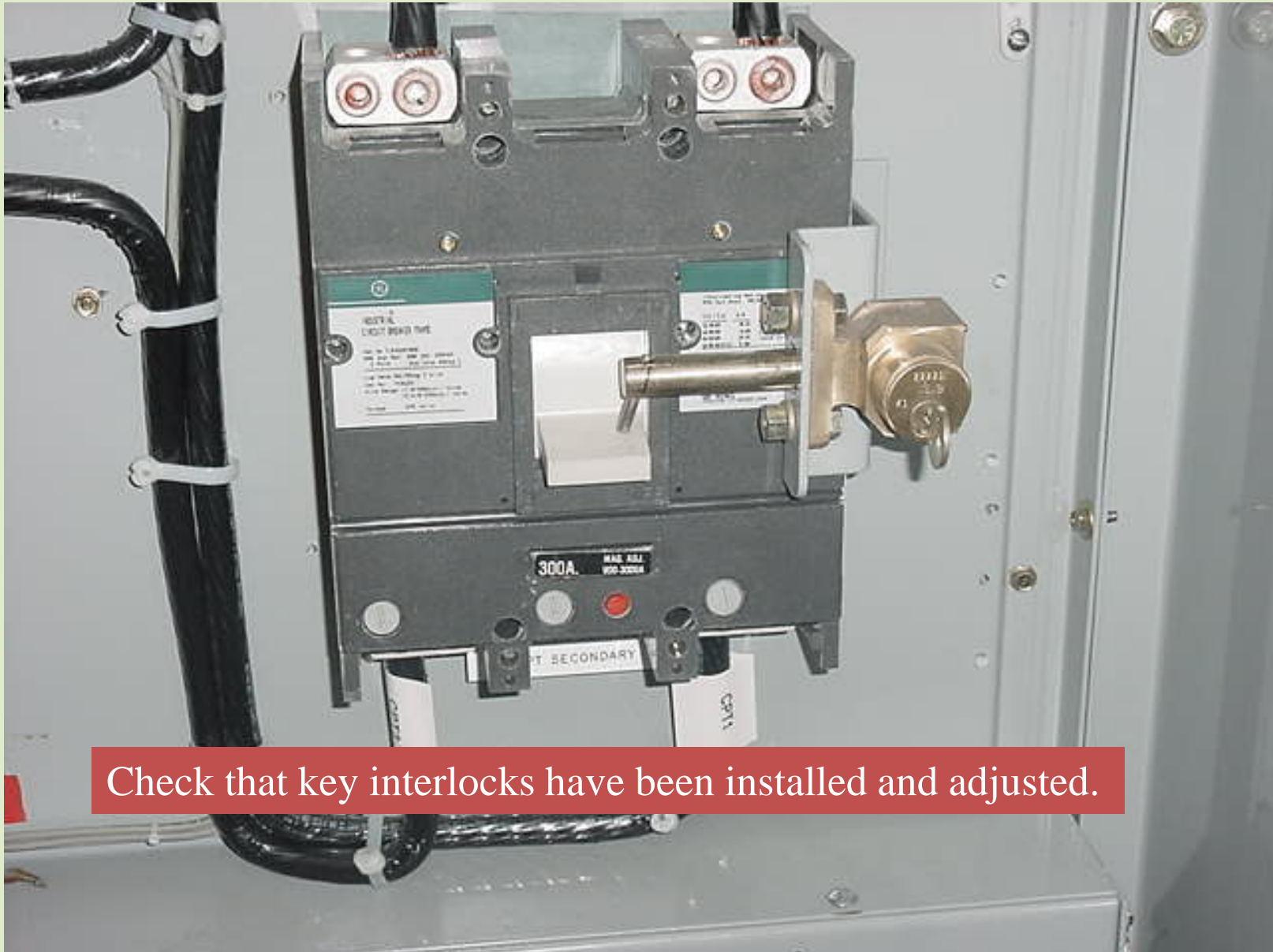

Check that key interlocks have been installed and adjusted.

Equipment Internal Inspection

Check that each key interlock assembly and the entire key interlock system operates correctly.

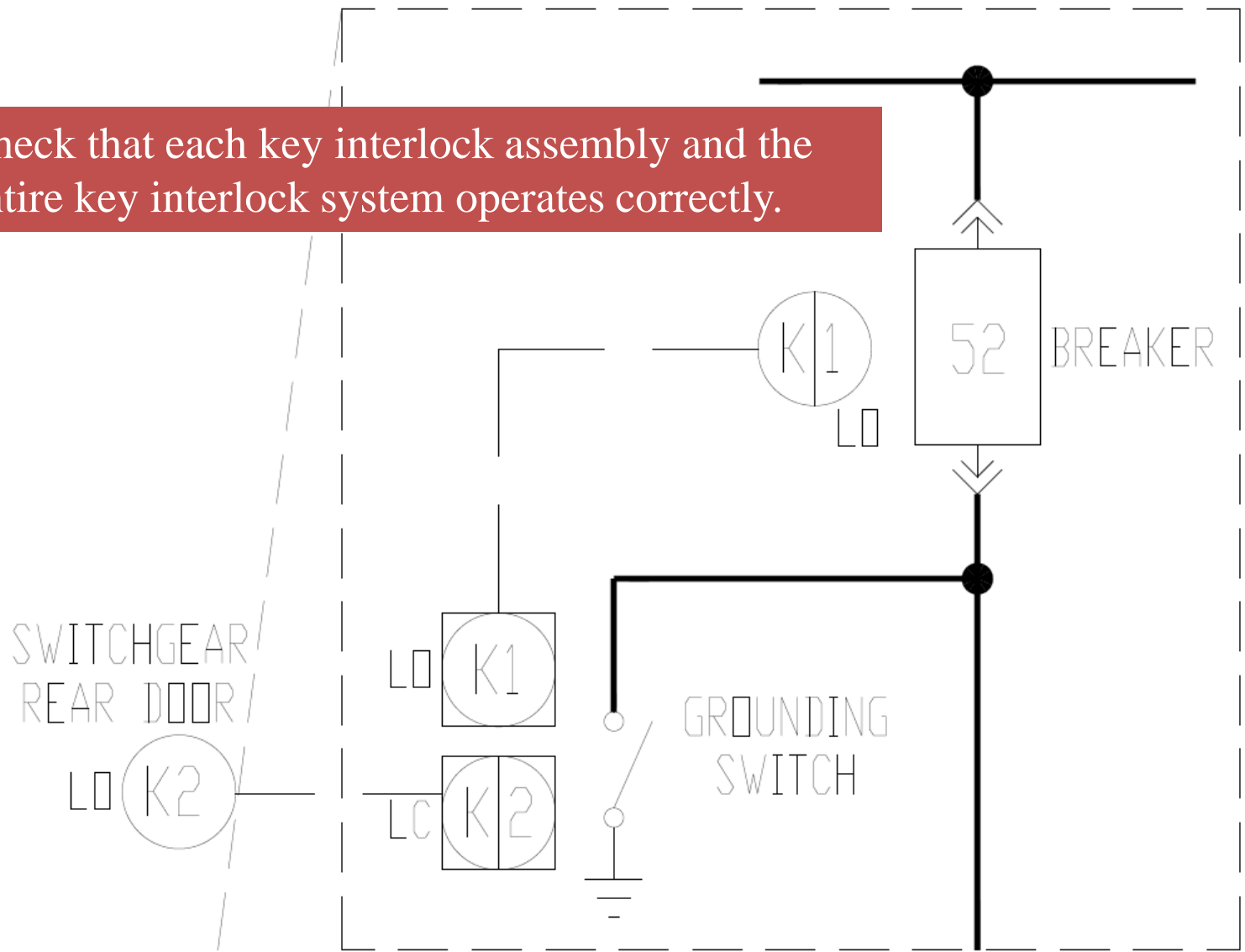

Equipment Internal Inspection

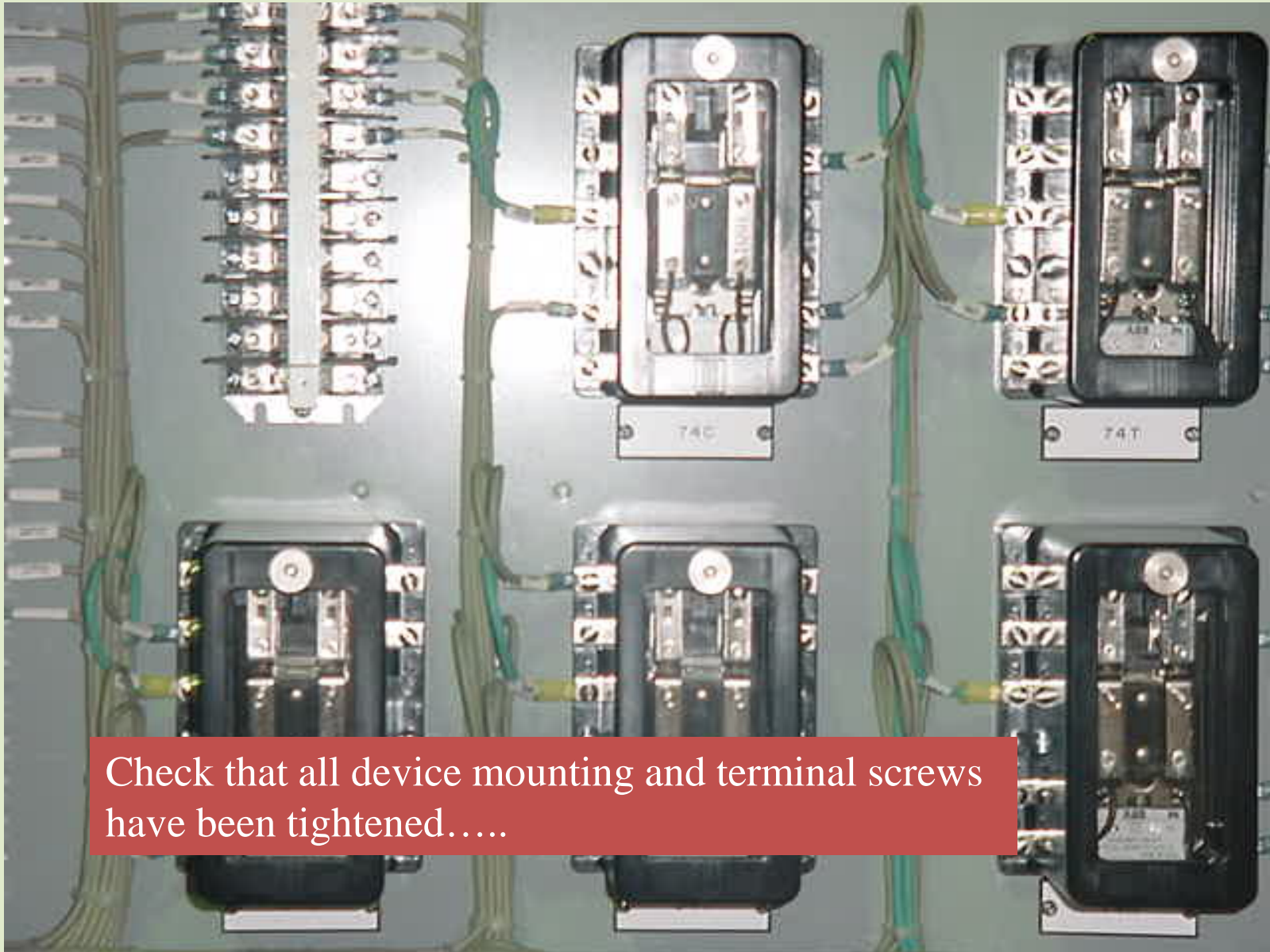

Check that all device mounting and terminal screws have been tightened.....

Equipment Internal Inspection

.....Check for correct crimping and tightness of all lug terminations.

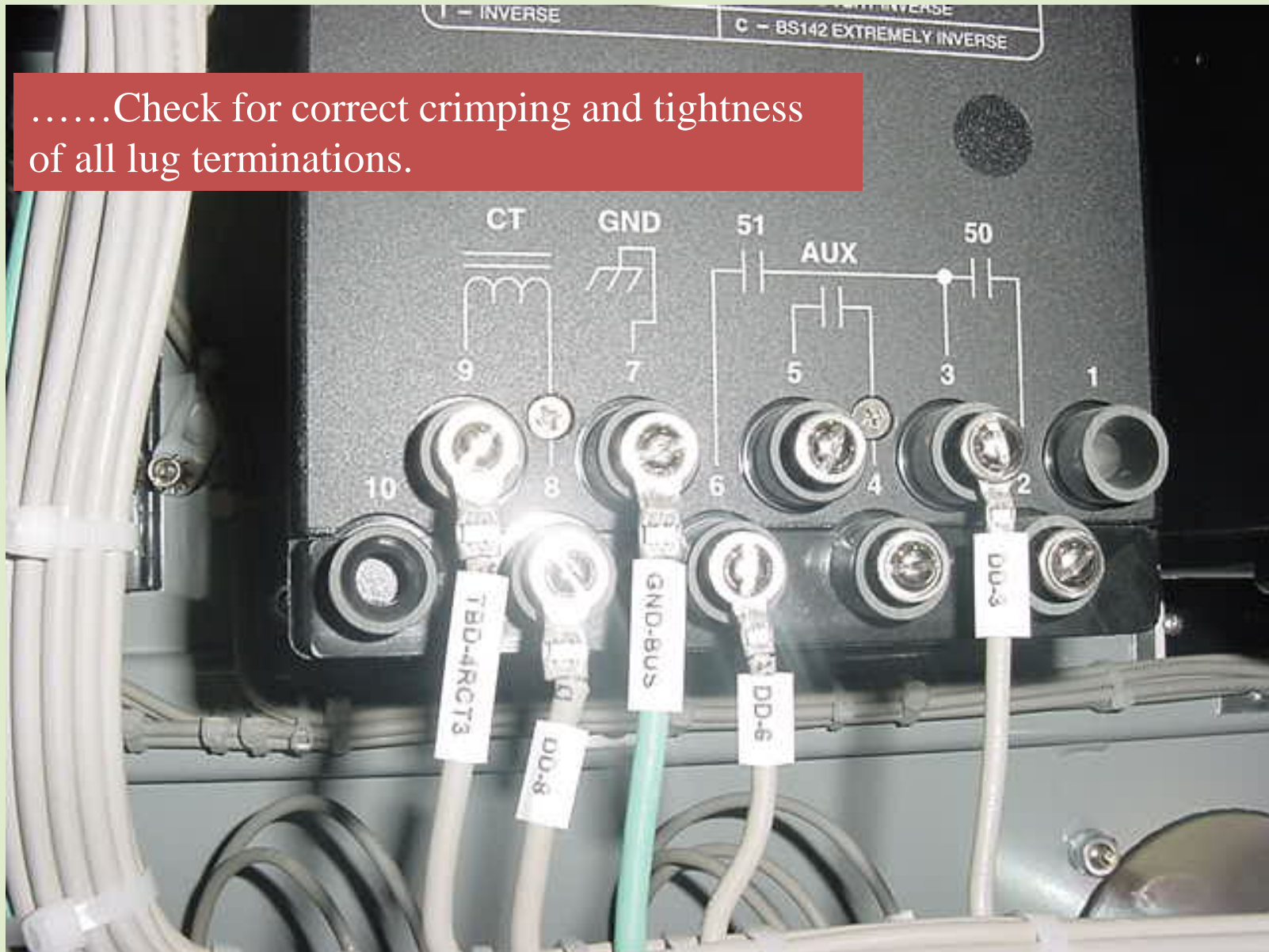

Equipment Internal Inspection



- Check that doors have been installed and adjusted.
- Check that nameplates have been installed in accordance with Master Copy print.
- Check all interconnect wiring against Master Copy print.

Equipment Internal Inspection



Check that door-bonding jumper has been installed.

Equipment Internal Inspection



Check that all CT's have been installed with polarity correct and wired in accordance with Master Copy wiring print.

Equipment Internal Inspection

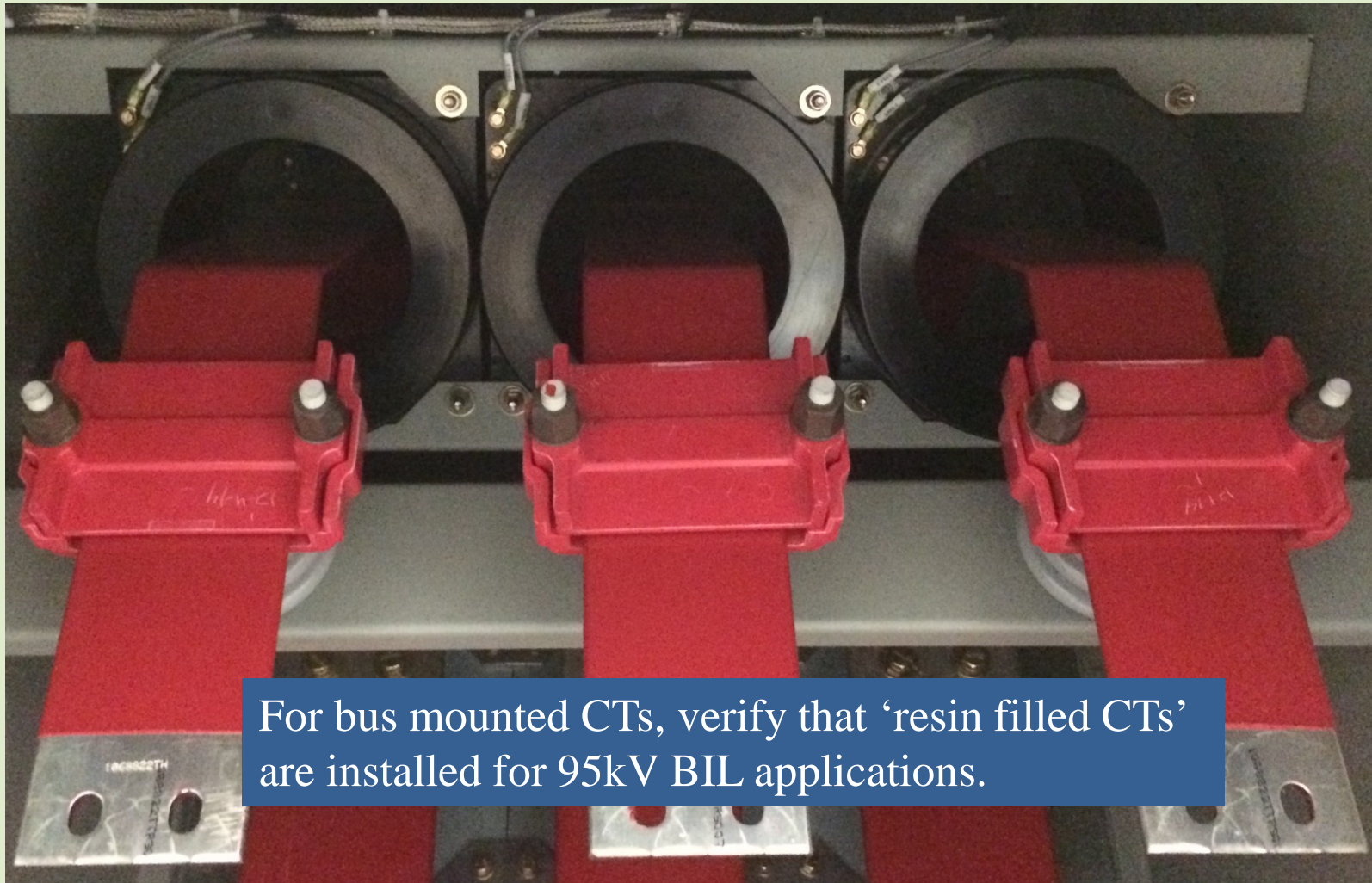

For bus mounted CTs, verify that 'resin filled CTs' are installed for 95kV BIL applications.

Equipment Internal Inspection

- Wire tags – checked against Master Copy wiring print.
- Check that all wire/metal jumpers have been installed in accordance with Master Copy wiring print.

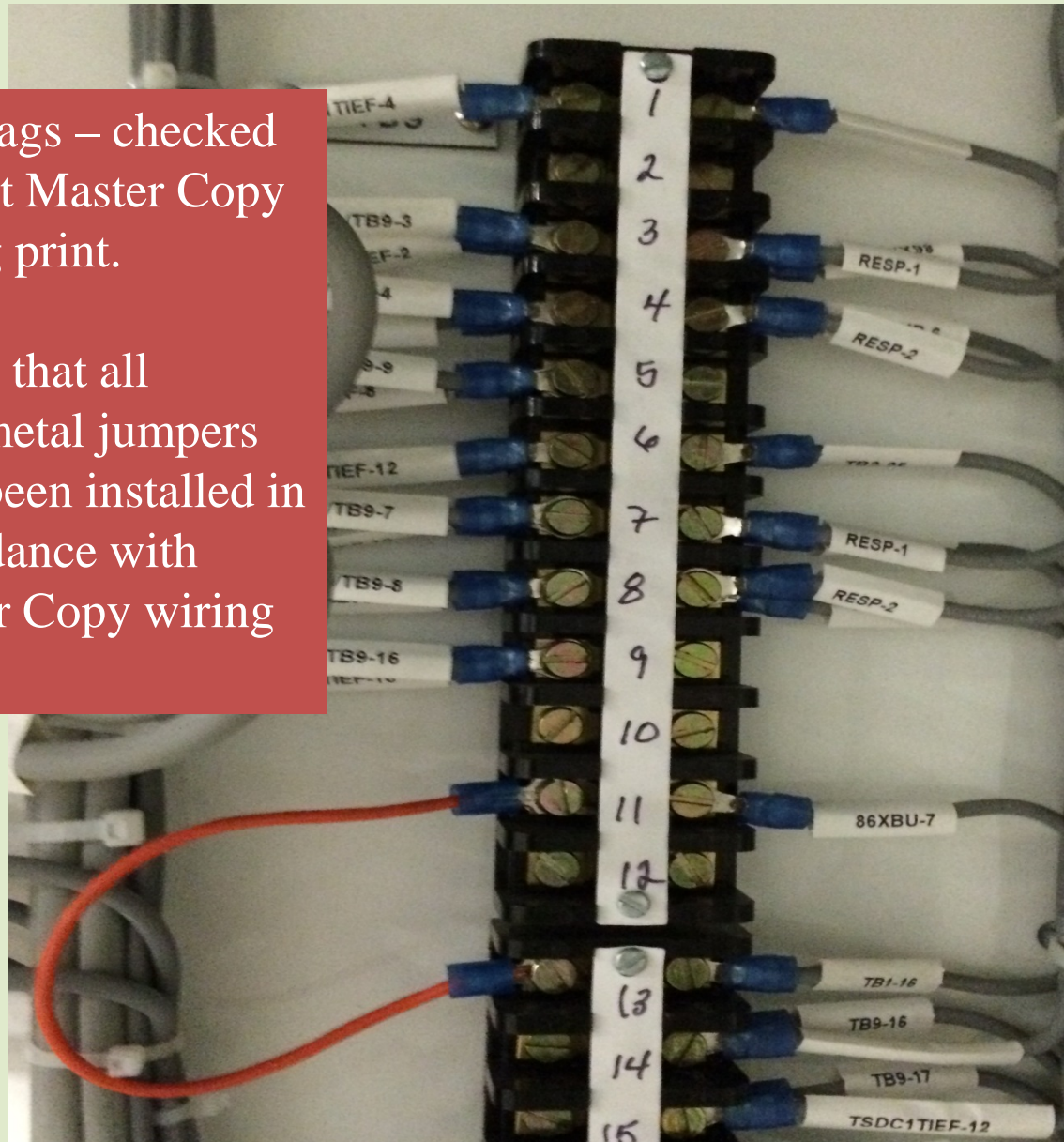

Equipment Internal Inspection



Check that low voltage wiring is isolated from high voltage by metal.

Equipment Internal Inspection

Check that mimic bus has been installed per Master Copy print.

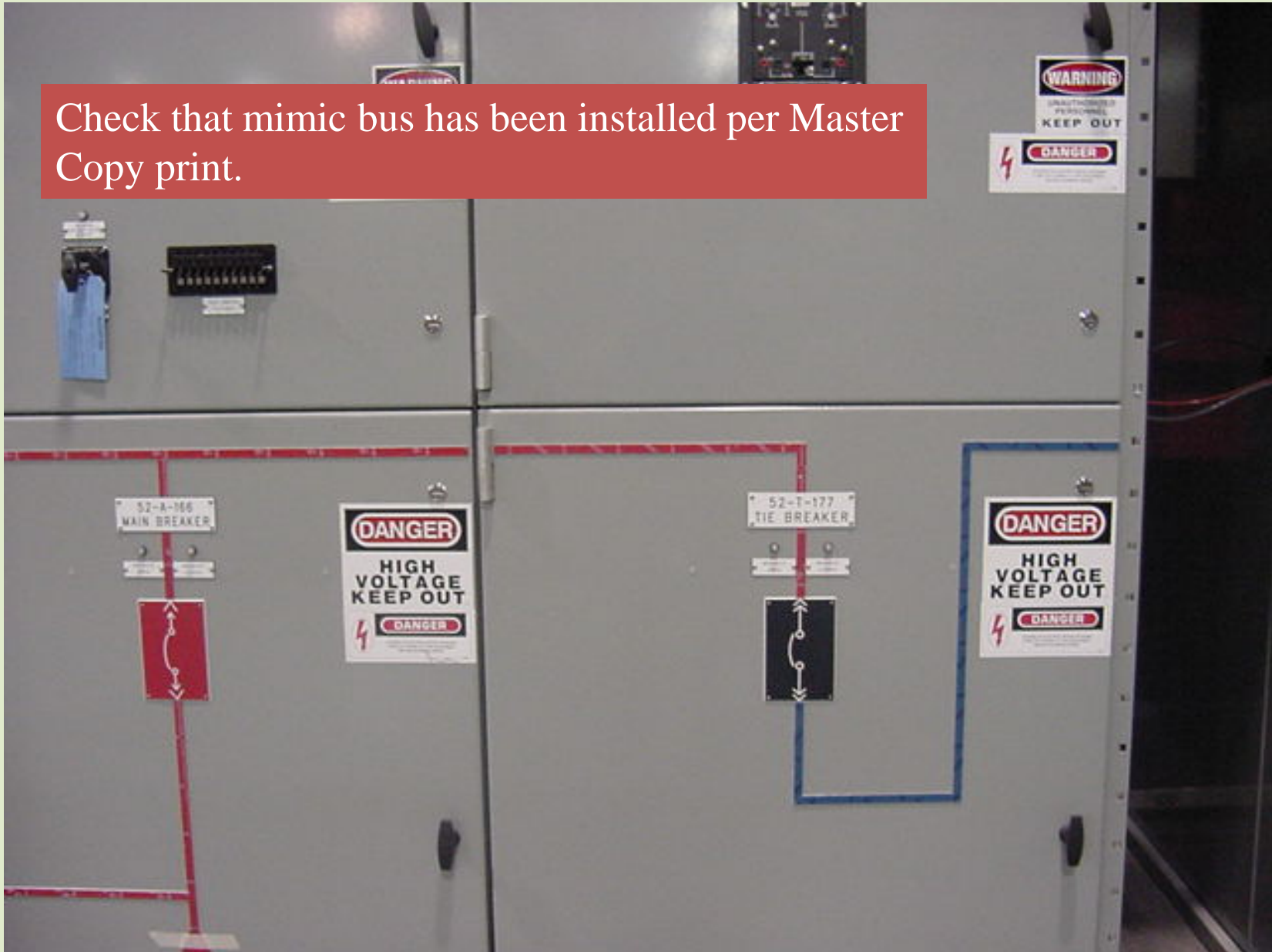



Equipment Internal Inspection

- **Review meeting minutes to see if all the project requirements are captured.**

For example:

- Check primaries of VTs are connected through hard copper bus.
- Check bus joints have boots and not tape.
- Check ring lugs are provided for current circuits.
- Check Origination-Destination type wiring is used
- Check test switch contacts connected in trip circuit has red handles.
- Check that all relays have conformal coating.

Equipment Internal Inspection

Final Inspection/Testing of the equipment:

- Visual Inspection
- Bussing Check
- Mechanical Tests
- CT Inspection
- UPS System Tests
- AC/DC Circuit Breaker Panel Tests
- Primary Injection Test
- High Voltage Test
- High Potential Test
- SS Automation Tests

CAUTION: BEFORE ENERGIZING EQUIPMENT REVIEW "SAFETY PROCEDURES FOR ELECTRICAL INSPECTION AND GENERAL TESTING PRECAUTIONS AND CHECKS".

Final Inspection/Testing of the equipment:

Type of Test	Purpose	What to check?
Visual Inspection	<ul style="list-style-type: none">• To verify base, layout, elevation, and door detail dimensions against Master Copy Drawings.• To verify all Material per Master Copy Drawings.• To ensure nameplates installed matches the Master Copy Drawings.	<ul style="list-style-type: none">• Measure all equipment dimensions per the drawings and highlight the acceptable dimensions in yellow.• Check all components against the Bill of Material. Investigate any differences in catalog numbers & material shortage.• Check all nameplates against the nameplate schedule. Investigate any differences in nameplates and/or spelling with the schedule.

Final Inspection/Testing of the equipment:

Type of Test	Purpose	What to check?
Bussing Check	<ul style="list-style-type: none">To ensure that the bussing of the equipment matches the drawings and is built to the standards.	<ul style="list-style-type: none">Check the three-line and sectional view drawings against the switchgear bus work.Check all bus clearances.Check that bus dimensions and phasing will line up to transformer or mating equipment drawings.Check that ground bus connections have been made between units and to mating equipment.

Final Inspection/Testing of the equipment:

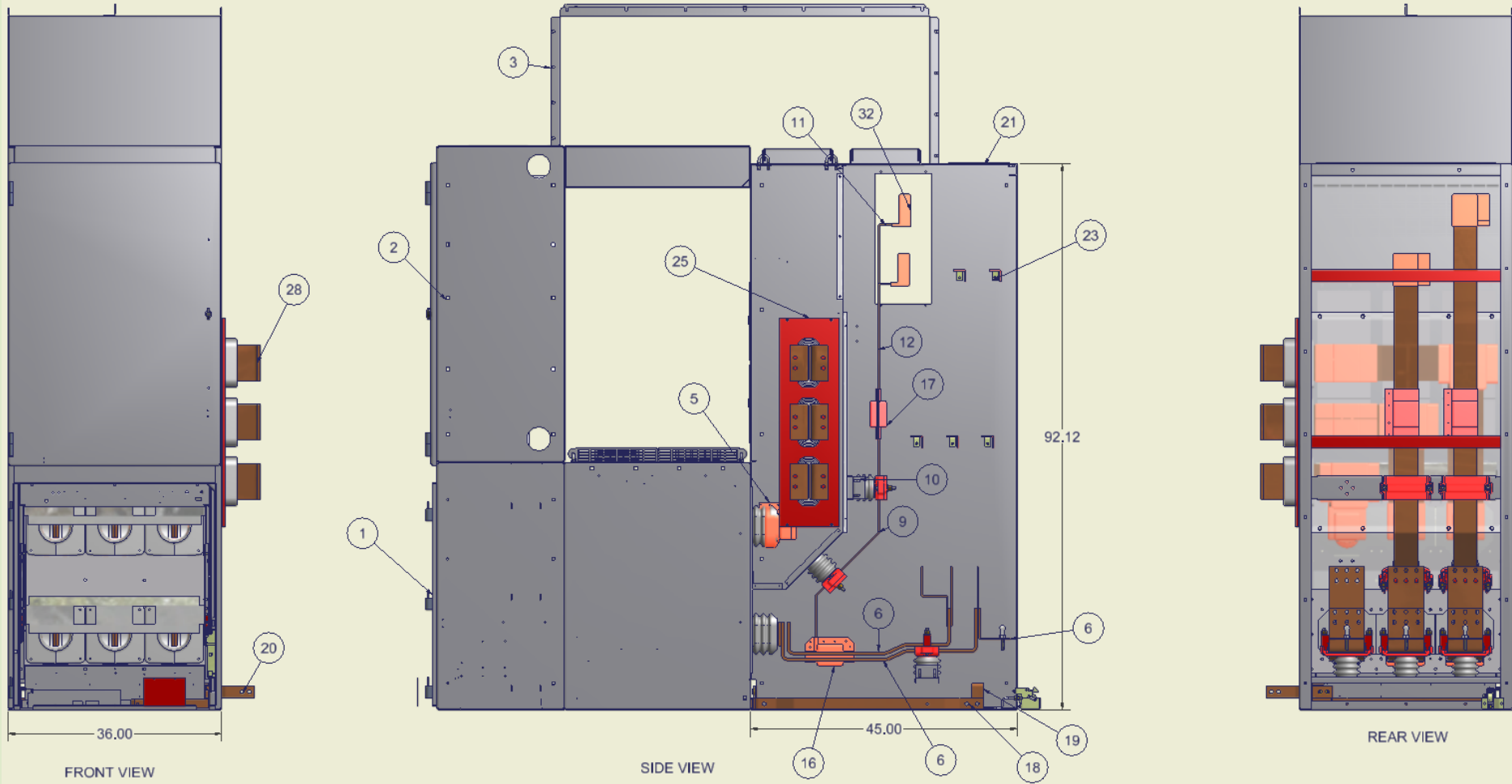

Final Inspection/Testing of the equipment:

Type of Test	Purpose	What to check?
Mechanical Tests	<ul style="list-style-type: none">To ensure the proper functioning of all the mechanical aspects of the equipment.	<ul style="list-style-type: none">Check all shutters, mechanical interlocks, racking mechanism, cell switches (mechanism and truck operated), and door interlocks for proper operation.Check all doors, locks, doorstops, mechanical interlocks, overhead lift devices, and louvers for proper operation.Check all key interlock systems (if applicable).Verify the interchangeability of all draw out or removable elements of the same rating. And those elements of a lower rating shall not be interchangeable with a higher rating element.

Final Inspection/Testing of the equipment:

Type of Test	Purpose	What to check?
CT Inspection	<ul style="list-style-type: none">To verify all relays, meters, and devices in the circuits operate as required by the three-line diagrams and schematics.	<ul style="list-style-type: none">Ensure that all circuits are verified; highlight each circuit with yellow marker as they are verified.Functional check the equipment per applicable control scheme and three-line diagrams.Perform circuit continuity check on any equipment, which cannot be functionally operated.

Final Inspection/Testing of the equipment:

Type of Test	Purpose	What to check?
Control Tests	<ul style="list-style-type: none">To verify all relays, meters, and devices in the circuits operate as required by the three-line diagrams and schematics.	<ul style="list-style-type: none">Ensure that all circuits are verified; highlight each circuit with yellow marker as they are verified.Functional check the equipment per applicable control scheme and three-line diagrams.Perform circuit continuity check on any equipment, which cannot be functionally operated.

Final Inspection/Testing of the equipment:

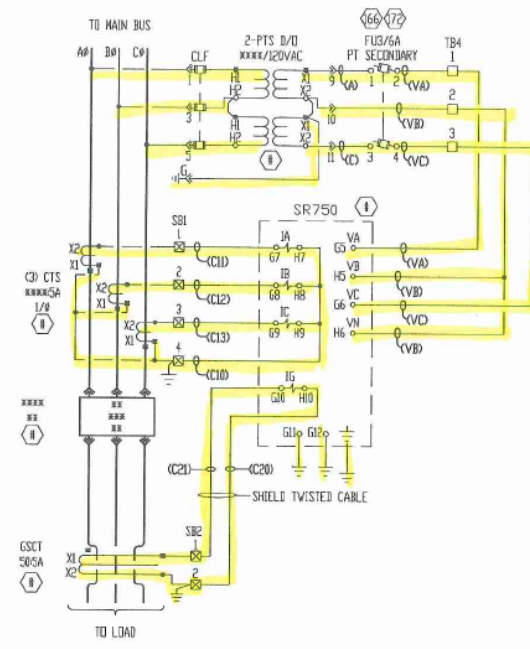
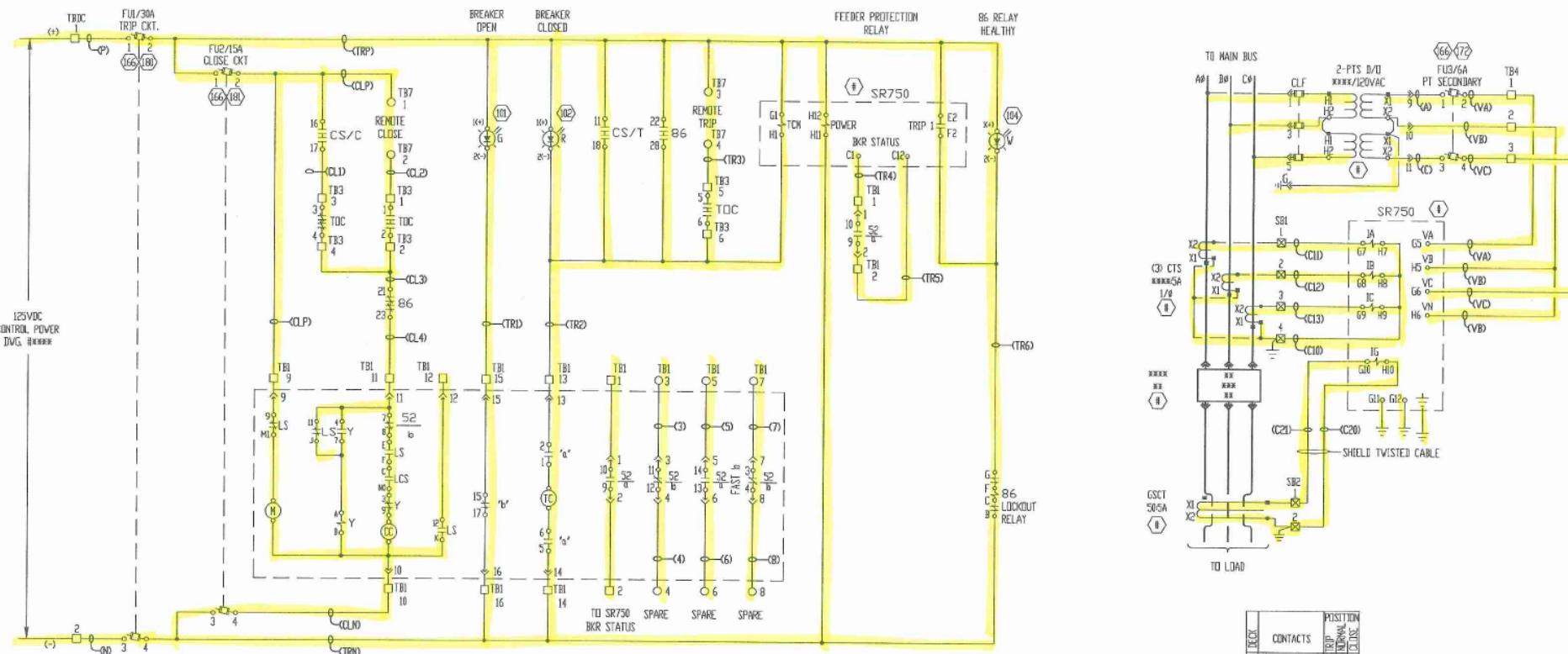

TERMINAL	CONTACTS	POSITION	
		TRIP	HEALTHY
11	11-11-1-17	X	
15	15-11-1-17		X

CIRCUIT BREAKER CONTROL SWITCH CAT. #2438D (23)

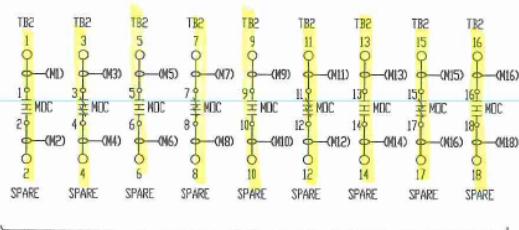

MDC CONTACTS ASSIGNMENT (1) (8)
CONTACTS SHOWN BREAKER OPEN

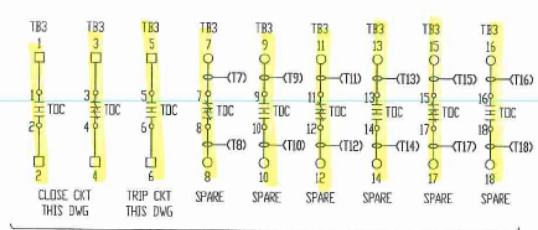

TOC CONTACTS ASSIGNMENT (1) (4)
CONTACTS SHOWN WITH BREAKER IN DISCONNECTED POSITION

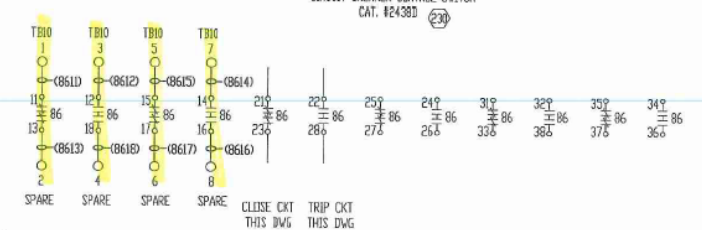

86 LOCKOUT RELAY CONTACTS ASSIGNMENT (24)

Final Inspection/Testing of the equipment:

Primary Injection Test:

Purpose:

- To verify instrument transformers circuits, ratio and ensure correct operations of primary disconnecting device.

Checks:

- Ensure that potential transformers and control power transformers mounted in rollouts have their primary fuses removed.
- Check bus work is clean and free from all debris.
- Check all current transformer polarity marks for proper orientation against the relay bulletin and three-line diagram.
- Verify all relay and current transformer connections with a buzzer before energizing circuit.

Final Inspection/Testing of the equipment:

Primary Injection Test:

Process:

- Connect current leads of test cart to incoming bus (observe phasing) with a bolted ring-tongue-lug arrangement. Connections should be tight to prevent arcing.
- Short the bus on the unit to be tested with a braided copper strap and turn current & control power on.



Final Inspection/Testing of the equipment:

Primary Injection Test:

Process (cont'd):

- Apply secondary potential on PT circuits to check all power type meters and relays.
- Verify CT ratio & polarity by varying the current and voltage to check that the test equipment readings match the equipment in test.
- Verify relay operations by varying current from the test cart and adjusting settings of protective relays to see if relay is picked up which will either trip the breaker or drop out the contactor.
- Ensure that all circuits are verified; highlight each circuit with yellow marker as they are verified.

Final Inspection/Testing of the equipment:

Primary Injection Test:



Final Inspection/Testing of the equipment:

High Potential Test:

Purpose:

- Hi-Pot testing is performed to demonstrate the ability of the insulation system to withstand the voltages in accordance with ANSI C37.09, IEEE C37.20.1, IEEE C37.20.2, ANSI/IEEE C37.20.3, ANSI/IEEE C37.23, IEEE C57.13 and NEMA Standards Publication No. ICS 1 & 3.

Checks:

- Check bus work is clean and free from all debris.
- Check that all bus boots have been installed.
- Check that clearances are within the limits per IEEE C37.20.1

Final Inspection/Testing of the equipment:

High Potential Test:

Checks (cont'd):

- Potential transformers and control power transformers mounted in rollouts must have their primary fuses removed and the rollout or tilt-out compartment inserted for the test.
- Check that wiring on rollout and in rollout compartment has been secured properly.
- Before applying test voltage, disconnect all glow tubes, lightning arresters, power factor correction capacitors, and surge capacitors.

Final Inspection/Testing of the equipment:

High Potential Test:

Process:

- Primary Hi-Pot tests are performed at the specified voltage listed in the relevant product's ANSI/IEEE standard's tables for voltage and rated insulation levels.

Table 1 - DC EQUIPMENT BUS WORK HI-POT VALUES

Equipment Type	Operating Voltage	Insulation Level (kV)	
		Rated Frequency Withstand	DC Withstand
DC Bus Duct	300/325	2.4	3.1
	800	4.2	5.9
	1200	4.8	6.8
	1600	5.4	7.6
	3200	8.8	12.4
DC LV Switchgear	300/325	2.2	3.1
	800	3.7	5.2
	1000	4.6	6.5
	1200	4.8	6.8
	1600	5.4	7.6
	3200	8.8	12.4

Final Inspection/Testing of the equipment:

Table 2 - AC EQUIPMENT BUS WORK HI-POT VALUES

Equipment Type	Max Operating voltage (kV)	Insulation Level (kV)	
		Rated Frequency withstand	DC Withstand
Switchboards	0.6	2.2	-
Nonsegregated-Phase Bus	0.635	2.2	3.1
	4.76	19	27
	15	36	50
	15.5	50	-
	27	60	-
	38	80	-
LV MCC	0.6	2.2	-
Metal-Enclosed LV Switchgear	0.254	2.2	3.1
	0.508	2.2	3.1
	0.635	2.2	3.1
E2 Controllers	2.5	7.625	-
	2.501 – 5.0	13.25	-
	5.001 – 7.2	18.2	-
Metal-Clad Switchgear	4.76	19	27
	8.25	36	50
	15	36	50
	27	60	①
	38	80	①
Metal-Enclosed Interrupter Switchgear	4.76	19	27
	8.25	36	50
	15	36	50
	27	60	②
	38	80	②

① See IEEE C37.20.2, Table 1, note b.

② See IEEE C37.20.3, Table 1, note b.

Final Inspection/Testing of the equipment:

High Potential Test:

Process (cont'd):

- With primary switching device in the connected position and closed, apply specified voltage (per tables) between each phase with other phases grounded.
- The High-Pot is a pass-fail test. Pass shall be that after reaching the specified test voltage the equipment will maintain that voltage for one minute.
- At the conclusion of the test, the voltage should be decreased slowly to the minimum obtainable before the circuit is opened.
- After the test has been completed, all circuit breakers and disconnecting switches must be opened and the high-potential cable grounded.

Final Inspection/Testing of the equipment:

High Potential Test:

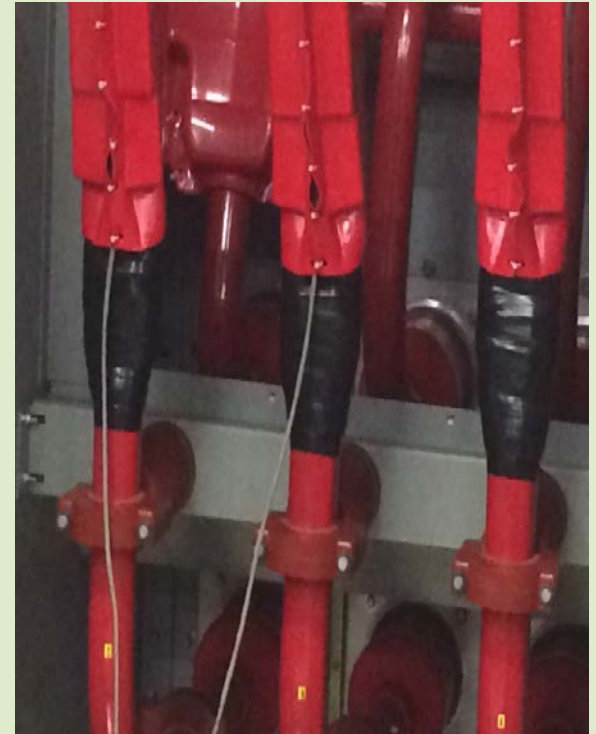

Final Inspection/Testing of the equipment:

High Potential Test:



Final Inspection/Testing of the equipment:

High Voltage Test:

Purpose:

- High voltage or system voltage testing is performed to run the primary system voltage on the equipment to energize potential transformers, control power transformers and to check out the associated secondary equipment in a situation as near to field conditions as possible.

Final Inspection/Testing of the equipment:

High Voltage Test:

Checks:

- Check all mechanical bus connections on roll-outs and tilt-outs and verify primary and secondary phasing with a buzzer.
- Place primary fuses back to potential transformers and control power transformers mounted in rollouts. Insert rollout/tilt-out compartment back in for the test.
- Connect ground wires on test cart to equipment under test and to building column ground.
- Ensure no other foreign voltages are present.

Final Inspection/Testing of the equipment:

High Voltage Test:

Process:

- Connect high voltage leads of HVTC to incoming bus (observe phasing) with a bolted ring-tongue-lug arrangement. Connections should be tight to prevent arcing.
- Test all components according to circuit requirements and highlight the prints with yellow marker as the circuits are completed.
- Once high voltage testing is complete deenergize the bus by switching off the circuit breaker on the HVTC control panel.
- Check bus work with voltage detector before disconnecting the high voltage leads. Secure the HVTC high voltage leads and the color coded power cable.

Final Inspection/Testing of the equipment:

Substation Automation:

- Substation automation testing are generally divided in two parts:
 - Factory Acceptance Tests (FATs): To verify communication architecture for all the equipment inside substations, IED configuration & management, testing activities related to ECMS etc.
 - Site Acceptance Tests (SATs): This involves detailed testing for each electrical piece of equipment that is connected to overall plant automation system either via hardwired interface or over a communication interface.



Final Inspection/Testing of the equipment:

Substation Automation:

- **Verify communication architecture**

- Ensure that all the communication cables are wired correctly between all IEDs, energy meters, Ethernet switches, communication processors etc.
- Verify all IRIG-B interconnections for precise time recording for all IEDs through satellite clock.
- Check all the IEDs, meters and other substation equipment like UPS, battery charger etc are communicating over the specified protocol (Modbus, DNP3, IEC 61850 etc)

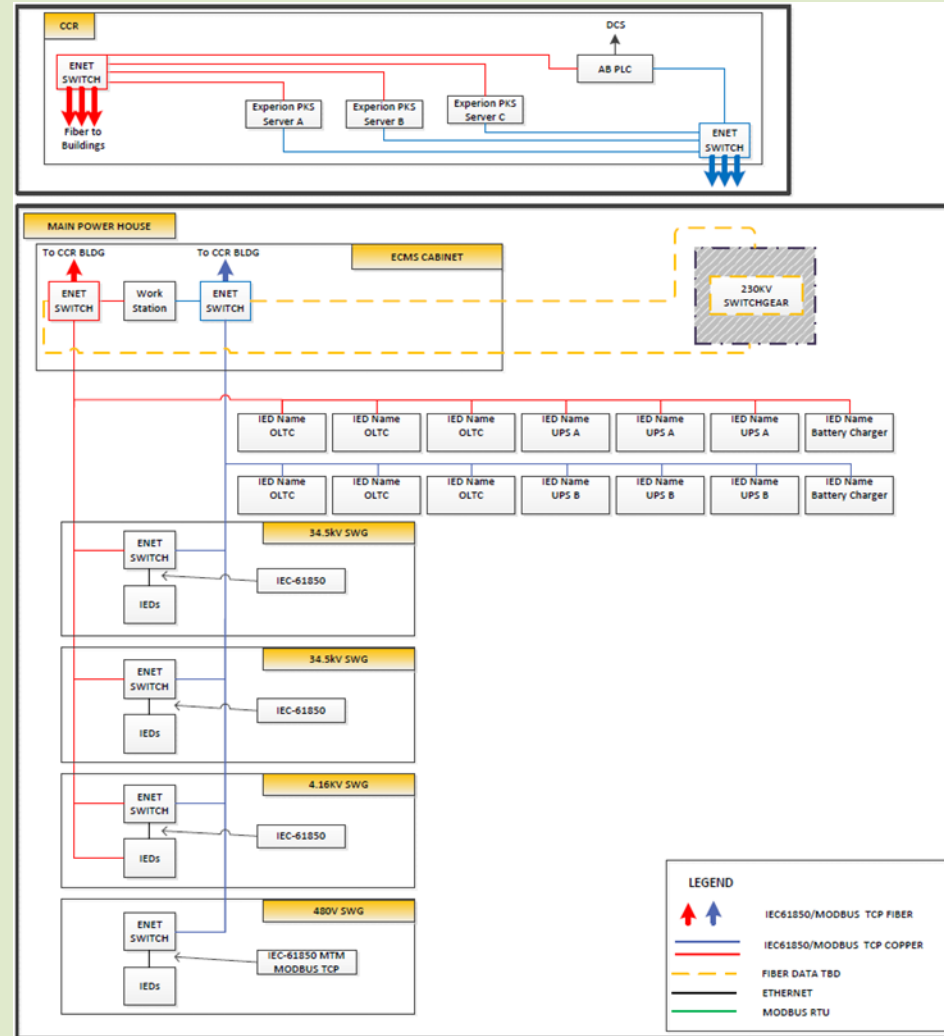

Final Inspection/Testing of the equipment:

Substation Automation:

- **If substation has electrical control & management system (ECMS),**
 - Verify that all analog and discrete data from all the IEDs is transferred over correct protocol.
 - Verify that system is able to perform remote switchgear operations, generator management, sequence of events, executing load shed/restoration controls etc per customer requirement.
 - Conduct static simulation of HMI during the process & check all analog and discrete data points that need to be displayed on HMI.
 - Ensure that HMI screens have all the relevant one-lines, all associated IED detail screens, remote control of MCCs/VFDs etc per customer specifications.

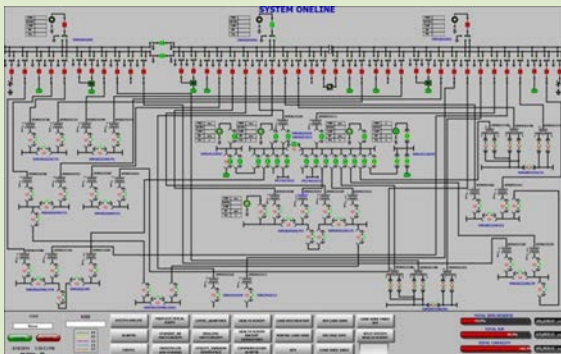

Final Inspection/Testing of the equipment:

Other Substation Equipment's Tests:

Type of Test	What to check?
UPS system tests	<ul style="list-style-type: none">• Check system out per manufacturer's bulletin.• Check functional operations for transfer and check all alarms and output contacts.• Check for full charging of batteries before shutdown of system.• Check panel breakers and/or fuses for correct size and rating.• Before shipment, check that the batteries are charged and disconnected.
AC & DC circuit breaker panel tests	<ul style="list-style-type: none">• Check all wires with buzzer to assure correct destination per drawings.• Check for correct voltage and phase rotation per drawings on line side of main breaker.• Check each feeder breaker one at a time to check that circuit works per Master Copy print.• Check each feeder breaker one at time with clamp-on ammeter to see that load current is per breaker size.
Battery Chargers	<ul style="list-style-type: none">• Check that battery chargers source breaker (LV MCC or panel breaker) current rating is correct per manufacturer's bulletin• Connect battery circuit of equipment under test to battery test cart with test cart charging system off.• Check for charging current on battery charger ammeter.• Check battery charger for alarms and troubleshoot system per Master Copy Prints and battery charger bulletin. Check all alarms against PLC and/or annunciator.• Turn off the charger by de-energizing all DC loads and restart again.
Annunciators	<ul style="list-style-type: none">• Annunciator systems are tested at the vendor's factory and they are generally tested for the interconnection to the associated equipment to be monitored during substation FAT.• Verify that description and location of all annunciator windows is per the drawings.• Start individual window testing and check that windows light up and alarm sounds.• Depress Silence button, horn will stop alarming but light will stay in blinking mode.• Depress Acknowledge button and all window lights will stop blinking.