

DIPOLES FOR DUMMIES

As well as the rest of us without a PhD in electromagnetics

Presented By:

Henry W. Ott

Henry Ott Consultants

Livingston, NJ 07039

(973) 992-1793

www.hottconsultants.com

hott@ieee.org

Presented at:

Santa Clara Valley IEEE EMC Chapter

May 8, 2012

© 2012 Henry W. Ott

HOC
ELECTROMAGNETIC
COMPATIBILITY

INTRODUCTION

- **An Understanding of some basic antenna theory would be helpful for all engineers, especially those involved in EMC.**
- **If a product radiates, or is susceptible to, rf energy it is an antenna even if you prefer to call it something else – such as a cable or PCB board.**
- **This presentation is a simple, insightful, and intuitive discussion of how a dipole antenna functions, and how that is related to the common-mode radiation from a product.**
- **Attendees will end up with a better understanding of dipole antenna theory and why that is so important to EMC engineers.**
- **All of this will be accomplished without using any mathematics or writing a single equation.**

© 2012 Henry W. Ott

HOC
ELECTROMAGNETIC
COMPATIBILITY

BASIC DIPOLES FOR DUMMIES

© 2012 Henry W. Ott

HOC
ELECTROMAGNETIC
COMPATIBILITY

DIPOLES

- A dipole is a very basic antenna structure consisting of two straight colinear wires.
- The first thing to observe about a dipole is that it has two parts

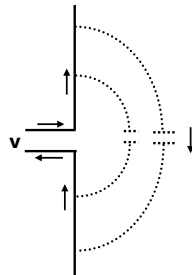

- How can one explain the fact that you can drive current into a dipole when the two ends are open.
- The simplest way to resolve this dilemma is to consider the parasitic capacitance between the two arms.
- Therefore, a dipole requires two parts in order to radiate.
- **Note, that a dipole does not require a ground to radiate.**

© 2012 Henry W. Ott

HOC
ELECTROMAGNETIC
COMPATIBILITY

MONOPOLES

- What about a monopole, does it require only one part to radiate?
- The answer is no, a monopole requires **two parts** to radiate.
- A monopole is just a dipole in disguise.
- The second part is usually a reference plane located below the one arm (pole).
- The current path in this case is through the capacitance from the one arm (pole) to the reference plane.
- Therefore, a monopole also requires two parts in order to radiate.
- Note, that even in the case of a monopole, **no ground is required for it to radiate**.

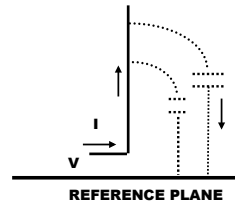

© 2012 Henry W. Ott

HOC
ELECTROMAGNETIC
COMPATIBILITY

SUMMARY

- Therefore, the way to make an antenna, dipole or monopole, is to have an rf potential between two pieces of metal.
- It does not matter what potential the two pieces of metal are at, only that there is a potential difference between them.
- The capacitance between the two pieces of metal will provide the current path.
- The radiation will be proportional to the magnitude of the current between the two pieces of metal.
- **The way to prevent the radiation is to:**
 - Somehow reduce the current between the two pieces of metal, or
 - Connect the two pieces of metal together so that they are at the same potential and, therefore cannot radiate since there will be no current through the parasitic capacitance between them.

© 2012 Henry W. Ott

HOC
ELECTROMAGNETIC
COMPATIBILITY

DIPOLES (MONOPOLES) AND EMC

- So what does all this have to do with EMC?
- It turns out quite a bit.
- Let's consider a simple product in a metallic enclosure, with a single cable attached to it.
- If there is a potential difference between the cable and the chassis, we have produced a monopole antenna.
- This potential difference is often referred to as a common-mode voltage.
- To make it interesting, let's assume that the product is orbiting the earth in space.
- Under these circumstances, I think that we can bypass the discussion on how we should "ground" the product.

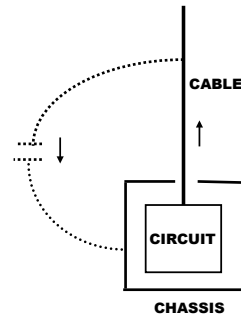

© 2012 Henry W. Ott

HOC
ELECTROMAGNETIC
COMPATIBILITY

SO WHAT CAN WE DO?

- Since we do not want a potential difference to exist between the cable and the chassis, how we connect the circuit to the chassis becomes very important.
- The internal circuit reference (often called "ground") should be connected to the chassis as close to where the cable enters the enclosure as possible.
- This connection must provide a very low rf impedance. At 200MHz a 1" long conductor has an impedance of approximately 20Ω (Not Exactly Low Impedance).
- This connection to chassis is often made with a poorly placed metal standoff(s), or worse yet by a long PCB trace to a single ground connection point.
- Seldom is this connection optimized for EMC purposes.
- This connection, and how it is made, is crucial to the EMC performance of the product.

© 2012 Henry W. Ott

HOC
ELECTROMAGNETIC
COMPATIBILITY

NOTE

- In the previous example, it matters not what potential the chassis is at with respect to the earth, or any other arbitrary reference.
- Only the difference of potential between the cable and the chassis matters.

-
- Now let's take our product out of orbit and bring it down to earth.
 - Does it matter how we ground the chassis to some external reference, such as the earth or the power-line ground?
 - Not from a radiation point of view.
 - The only requirement is to have no common-mode voltage between the cable and the chassis.

© 2012 Henry W. Ott

HOC
ELECTROMAGNETIC
COMPATIBILITY

INTERMEDIATE DIPOLES FOR DUMMIES

© 2012 Henry W. Ott

HOC
ELECTROMAGNETIC
COMPATIBILITY

DIPOLE/MONOPOLE CURRENT DISTRIBUTION

- Let's now determine the current distribution along the length of a monopole antenna.
- The same result will be applicable to a dipole, if we apply the result to each arm individually.
- Let's drive a current "1" into the base of a monopole antenna. The current at the tip of the antenna must be zero.
- If the antenna is short ($< \frac{1}{4}$ wavelength), the current distribution will be linear.
- If the antenna is long, the current distribution will be sinusoidal.

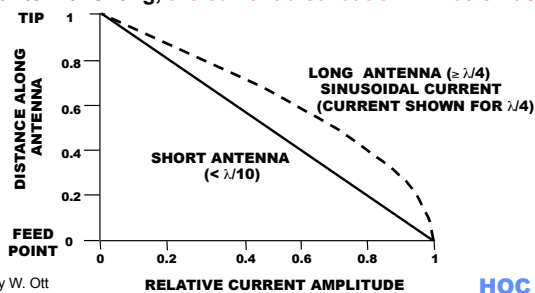

© 2012 Henry W. Ott

HOC
ELECTROMAGNETIC
COMPATIBILITY

DIPOLE/MONOPOLE RADIATION

- Clearly, the antenna does not radiate uniformly along its entire length.
- The bottom mm will radiate the maximum, and the top mm will hardly radiate at all.
- For a short antenna, the average current will be 0.5 I.
- For a quarter wavelength antenna, the average current will be 0.637 I.
- Compared to an "ideal" antenna (one having uniform current across its entire length) a short antenna will produce only 50 % as much radiation.
- Compared to an "ideal" antenna (one having uniform current across its entire length) a quarter wavelength antenna will produce only 63.7 % as much radiation.

© 2012 Henry W. Ott

HOC
ELECTROMAGNETIC
COMPATIBILITY

INCREASING MONOPOLE/DIPOLE RADIATION

- How can we make the antenna more efficient?
- By increasing the average current.
- This means forcing more current up to the top.
- Since the current flows through the parasitic capacitance of the antenna arm,
- We must do something to increase the capacitance between the top of the antenna and the reference plane.
- The figure (above, right) shows what is often called a “top hat” or a capacitively loaded antenna.
- The top hat can be a metal disk, radial wires, a sphere, etc.
- A similar approach can be used in the case of a dipole, only now we must apply the top hat to the ends of both arms.
- This is often called a “dumbbell” antenna.

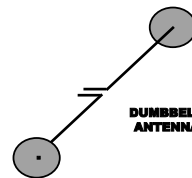
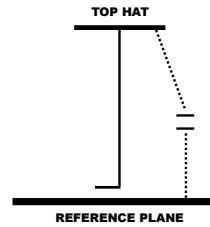

© 2012 Henry W. Ott

HOC
ELECTROMAGNETIC
COMPATIBILITY

HOW DOES THIS RELATE TO EMC?

- You don't want to configure your product in such a way that you produce a top hat antenna.
- The figure shows a product that consists of a PCB connected at the end of a long cable mounted a significant distance above a metal chassis.
- The cable is the monopole, the PCB is the top hat, and the chassis is the reference plane. The structure will radiate very efficiently.
- Therefore, when a PCB is mounted in a product with a metal chassis, it should be mounted as close to the chassis as possible, and have its reference plane (ground) connected to the chassis.

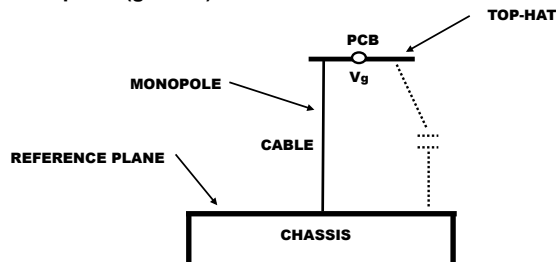

© 2012 Henry W. Ott

HOC
ELECTROMAGNETIC
COMPATIBILITY

ADVANCED DIPOLES FOR DUMMIES

© 2012 Henry W. Ott

HOC
ELECTROMAGNETIC
COMPATIBILITY

DIPOLE IMPEDANCE

- Let's determine the impedance of both a dipole and monopole.
- Impedance is important because it affects our ability to couple energy into, or extract energy from, the antenna structure.
- The wire that the antenna is made from has inductance, and the current flows through the parasitic capacitance between the antenna arms (poles).
- Therefore, the impedance will consist of an inductor in series with a capacitor.
- If the antenna radiates, some energy is lost and this must be accounted for in our model.
- The only component that will dissipate power is a resistor. We will call this the radiation resistance.
- Therefore the equivalent circuit of a dipole must be a **series R-L-C network**.

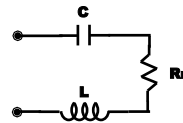

© 2012 Henry W. Ott

HOC
ELECTROMAGNETIC
COMPATIBILITY

MONOPOLE IMPEDANCE

- From the figure below we can clearly see that the impedance of a monopole is one half that of a dipole
- The inductance and resistance will be one half that of a dipole
- The capacitance will be twice that of a dipole

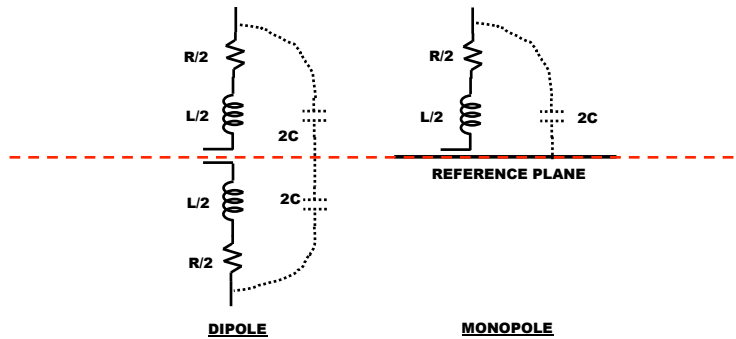

© 2012 Henry W. Ott

HOC
ELECTROMAGNETIC
COMPATIBILITY

THEORY OF IMAGES

How do the fields produced by a dipole compare to the fields produced by a monopole? To answer this we can use the theory of images.

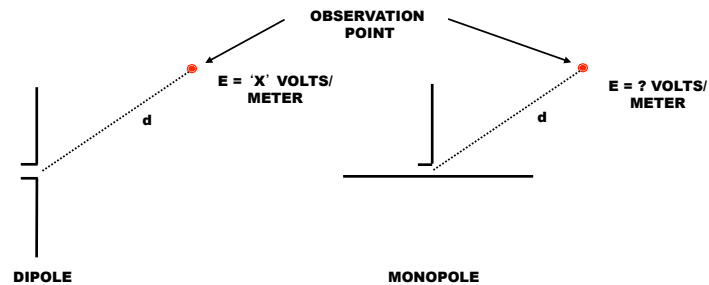

As long as we limit ourselves to the fields in the upper hemisphere,
The monopole and dipole produce the exact same field.

© 2012 Henry W. Ott

HOC
ELECTROMAGNETIC
COMPATIBILITY

SUMMARY

- Both Dipole and Monopole Antennas Require Two Parts
- Neither a Dipole or Monopole Require a “Ground” to Radiate
- The Magnitude of the Radiation is Proportional to the Antenna Current
- Adding Metal (Capacitance) to the End(s) of a Dipole/Monopole Will Increase the Radiation
- The Impedance of a Dipole/Monopole is a Series R-L-C
- At the Resonant Frequency, it is Much Easier to Couple Energy Into a Dipole/Monopole
- A Dipole and Monopole Both Produce the Same Field (in One Hemisphere)
- The Way to Make an Antenna is to Have an RF Potential Between Two Pieces of Metal
- The Way to Prevent Radiation, is Not to Have an RF Potential Difference Between the Two Halves of the Antenna

© 2012 Henry W. Ott

HOC
ELECTROMAGNETIC
COMPATIBILITY

BIBLIOGRAPHY

- Ott, H. W., *Electromagnetic Compatibility Engineering, Appendix D (Dipoles for Dummies)*, John Wiley & Sons, 2009.
- Iizuka, K. “Antennas for Non-Specialists,” *IEEE Antennas and Propagation*, February, 2004.

© 2012 Henry W. Ott

HOC
ELECTROMAGNETIC
COMPATIBILITY