



CSA
Group

Luminaires in general, LED & Retrofit kits

Presented by: Pradeep (Jolly) Sharma
November 26, 2013



- Certification of lighting products – North American
 - Testing laboratories shall be accredited by OSHA for US and accredited by SCC for Canada

Luminaire



- Hundreds of new and exciting lighting products are introduced in the U.S. each year, bringing with them significant business opportunities, but also a product testing and certification challenges.
- How best to get your products to market on time and on budget?

Luminaire Construction



Submitting the product(s), following shall be considered:

- Construction/design of the product
 - Enclosure: metal or non metallic type
 - May have specific thickness for metal enclosure and shall be as per standard.
 - Polymeric material: Shall have flammability ratings and RTI (Relative Thermal Index) to UL 746C etc. as per standard.
 - Barrier
 - Grounding means etc.

Intended for any either Dry, damp or Wet location.

Luminaire Construction



Mounting means :

- Such as Pendant, pole post, ceiling (suspended or surface), wall, recessed (IC or Non IC), portable etc.
- Critical Components or Parts:
 - It is advisable to have certified components intended for the application, because of it is cost effective for certification process.
 - See next slide for some of the critical components.

Luminaire Components

Wall Mount



- Components such as:
 - Wire, Wiring Devices
 - Power supply, Transformers, Ballast, LED drivers etc.
 - Lamp holder
 - Gasket
 - Strain Relief
 - Printed Wiring Board (PWB)
 - Fuses and Fuse holder
 - Switches.
 - etc.

Ceiling Mount - Indoor



- Some of the lighting standards:
 - UL 1598 Luminaires
 - UL 8750 LED Equipment for use in lighting
 - UL 48 Electric Signs
 - UL 153 Portable Luminaires
 - UL 234 Low-Voltage Lighting Fixtures for Use in RVs
 - UL 676 Underwater Lighting Fixtures
 - UL 924 Emergency Lighting and Power Equipment

Recessed Lighting



- UL 935 Fluorescent Lamp Ballasts
- UL 1433 Control Centers for Changing Message Type Electric Signs
- UL 1573 Stage and Studio Luminaires and Connector Strips
- UL 1574 Track Lighting Systems
- UL 1598A Supplemental Requirements for Luminaires for Installation on Marine Vessels
- UL 1598B Supplemental Requirements for Luminaire Reflector Kits for Installation on Previously Installed Fluorescent Luminaires

Standards Continued



- UL 1786 Nightlights
- UL 1838 Low Voltage Landscape Lighting Systems
- UL 1993 Self-Ballasted Lamps and Lamp Adapters
- UL 2108 Low Voltage Lighting Systems
- UL 2388 Flexible Light Cable Systems
- Etc.

Most common type of illumination sources

Landscape Lighting



- Incandescent (Possibly Phasing out)
- Fluorescent
- HID: LPS, HPS & MH
- Halogen
- Induction
- LED (New Generation)
- Etc.



- Some of the common tests:
 - Temperature
 - Abnormal
 - Dielectric withstand or Hi Pot
 - Bond Impedance
 - Articulate probe
 - Strain relief
 - Rain
 - Many more as per standard requirements depending on product features



- We see LED as a light source everywhere and it is growing rapidly:
 - In departmental stores, Grocery stores, Street lights, Traffic lights, exit signs, cell phone – Discuss later in detail
- Benefits of LED
 - Energy efficient (Approx. 100,000 hour lifespan)
 - Long life
 - Smaller size etc.
 - Impact and vibration resistant

LED New Generation



- Reduces energy cost drastically
- Deliver 25% more light to work area than standard CFL or incandescent
- Instant on
- Dimmable
- Environmental friendly

LED New Generation



- Home lighting: Imagine a “light-bulb” with 100,000 hours of use. In other words:
 $100,000 \text{ hours} / 24 \text{ hours a day} = 4,166 \text{ days}$
 $4,166 \text{ days} / 365 \text{ days a year} = 11.4 \text{ years.}$
- Not only will the light bulb last for 11.4 years, but it will also require much less energy than a traditional light-bulb. If one LED-light bulb requires half the energy of one Incandescent light-bulb, we may not have to suffer through blackouts ever again!

LED Lighting Applications



- Commercial and Residential Lighting
- Architectural
- Sign
- Hand Held
- Solar
- Stage and Studio
- Vehicle tail and dashboard
- General lighting
- Medical



LED Luminaires Consist of:

- LED Lighting Unit - LED package, array, or module that converts electrical energy to light
- LED Package: An assembly of one or multiple LED that contains wire bond connections, possibly with an optical element and thermal, mechanical, and electrical interfaces. The device does not include a POWER SOURCE



- **LED Controller** - Control circuitry that may switch, dim or otherwise control the electrical energy to the LEDs.
- **LED ARRAY:** An assembly of LED packages on a printed circuit board, possibly with optical elements and additional thermal, mechanical, and electrical interfaces. The device does not contain a **POWER SOURCE** and is not connected directly to the branch circuit.
- **LED Driver(s)** - Power source that supplies the necessary voltage and current to operate the LEDs

Power Source



LED Drivers or Power Source Standards

- UL1310 – Class 2
- UL1012
- UL60950 Part 1
- UL 8750 LED



- Transformers
 - UL 5085-1 & 3 Low Voltage
 - UL 5085-2 Low Voltage General purpose.
 - UL 1411 Audio, Radio and Television
 - UL 1561 Dry Type General purpose.



Mechanical

- Enclosures & barriers
- Conductor protection
- Strain Relief

Electrical

- Accessibility
- Input / Output Connections & Terminals
- Internal wiring
- Insulating materials & PWB's
- Spacing's
- Protective Devices etc.

Performance Tests



Performances

- Input Test
- Normal Temperature Test
- Abnormal Test
 - LED driver subjected to Short Circuit test unless previously evaluated
- Dielectric Voltage Withstand
- 50 W power measurements
- Leakage Current
- Cord strain & Pushback relief
- Security of output

Performance Tests



- Insulation-piercing connection thermal cycling test
- Adhesive support
- Environmental
- Mechanical strength tests for metal enclosures
- Determination of low-voltage, limited-energy circuit status
- Knockout secureness test
- Thermal aging test
- Impact

Retrofit Kit

T8/T10/T12 Fluorescent Light Fixture

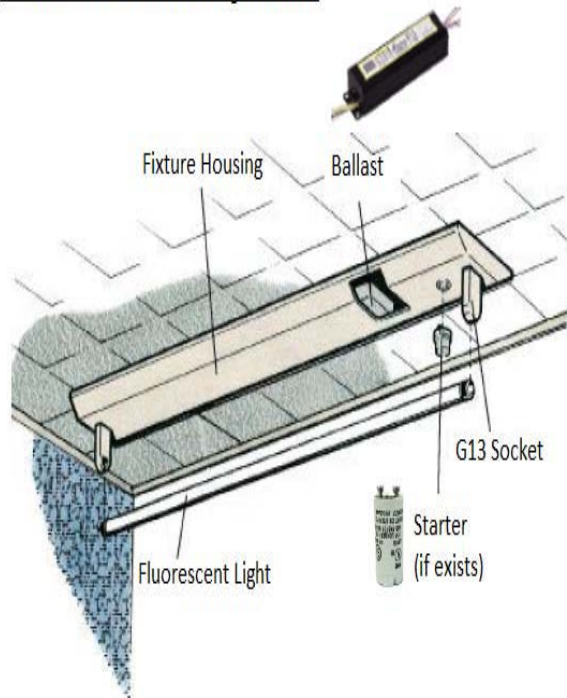

- Power Source
 - As per Standard evaluated to
- LED and Control Modules
 - Manufacturer
 - Model name or number
 - Ratings: Input Volts, Amps, or Watts
 - Date of manufacture
- Other markings:
 - As per standard requirements such as Class Type, Wall mount, Environmental, mountings etc.

Retrofit Kit



- Light-emitting diode (LED) retrofit luminaire conversion kits that are intended to replace existing light sources and systems including incandescent, fluorescent, induction, and high intensity discharge (HID) light sources in previously installed luminaires that already comply with the requirements in the Standards UL 1598.
- Retrofit Kits Standards (LED): UL 1598C, CSA TIL B-79, UL 8750 and CSA 250.13.

Retrofit Kits

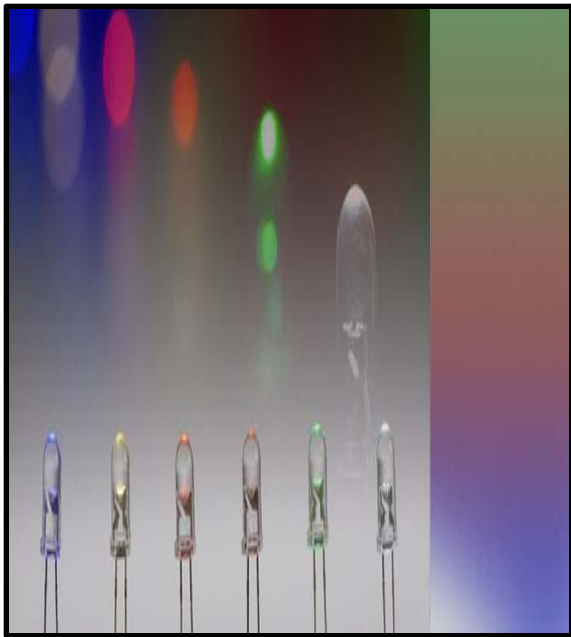

The kits are intended for use on:

- a) Luminaires where specific luminaire model or part numbers are identified in the kit installation instructions or
- b) One or more generic type luminaires that meet specific criteria identified in the installation kit instructions.

Retrofit Kits Diagram

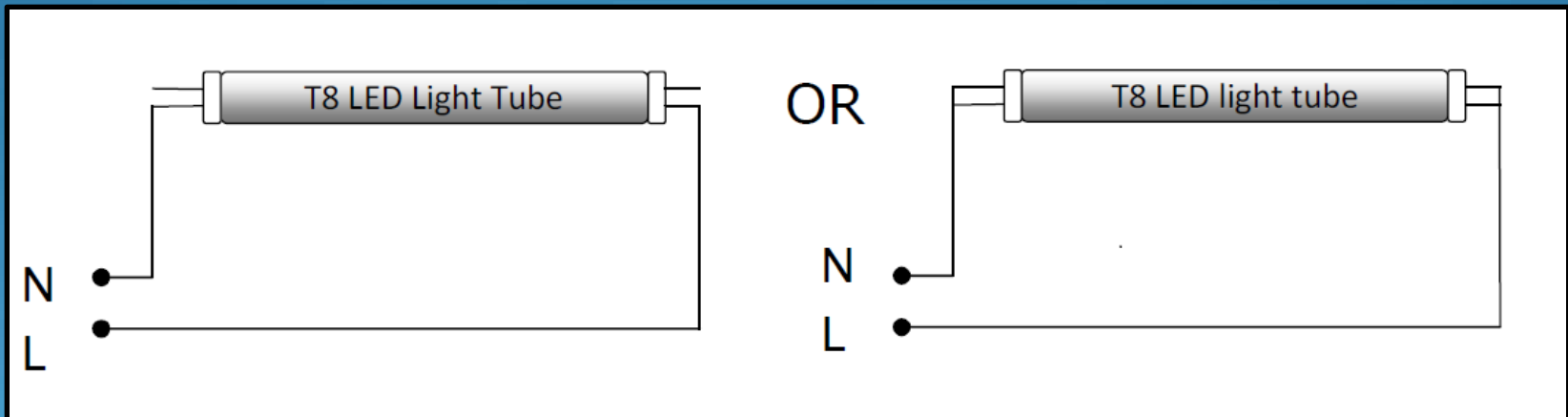
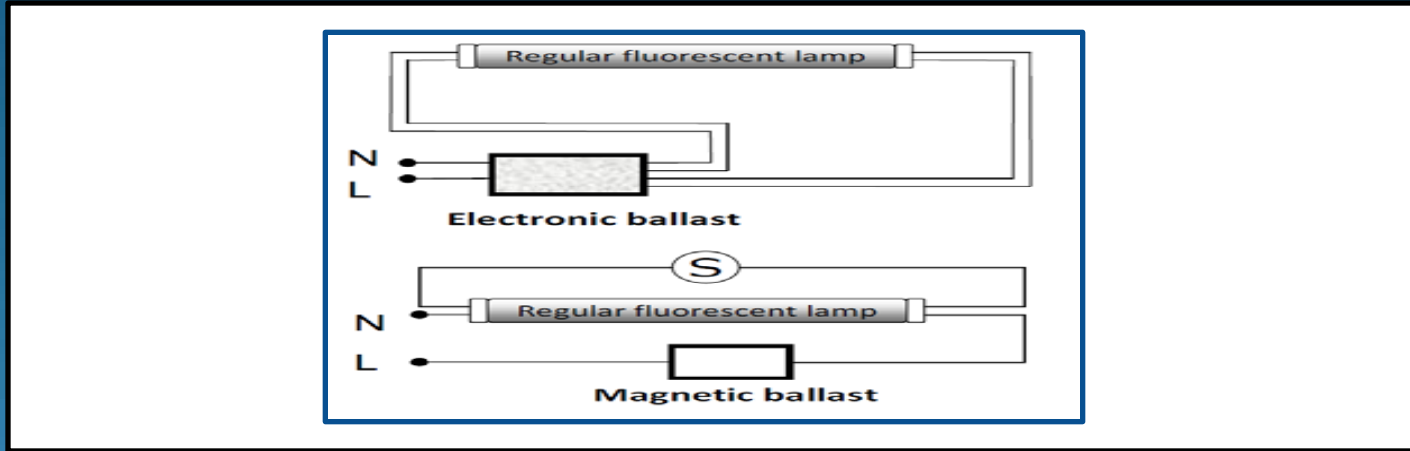

LED Retrofit kits



LED retrofit Kits Included:

- LED Lamps & Arrays including LED Tubular lamp
- Control modules
- Power supply
- Wiring
- Lamp holder
- Brackets
- Wire connectors
- Reflector
- Diffuser
- Mechanical, electrical or optical devices

Conclusion

Any

Questions?