

# Ultra Low Power Electronics in the Next Decade



**Ajith Amerasekera**

**Texas Instruments Inc.  
Dallas, USA  
February 2012**

**[amerasekera@ti.com](mailto:amerasekera@ti.com)**

***SSCS Distinguished Lecture***

# OUTLINE

- Growth in Electronics
- What Do We Need?
- Next Steps in Low Power Electronics
- Key Challenges
- Conclusion

# Growth in Electronics

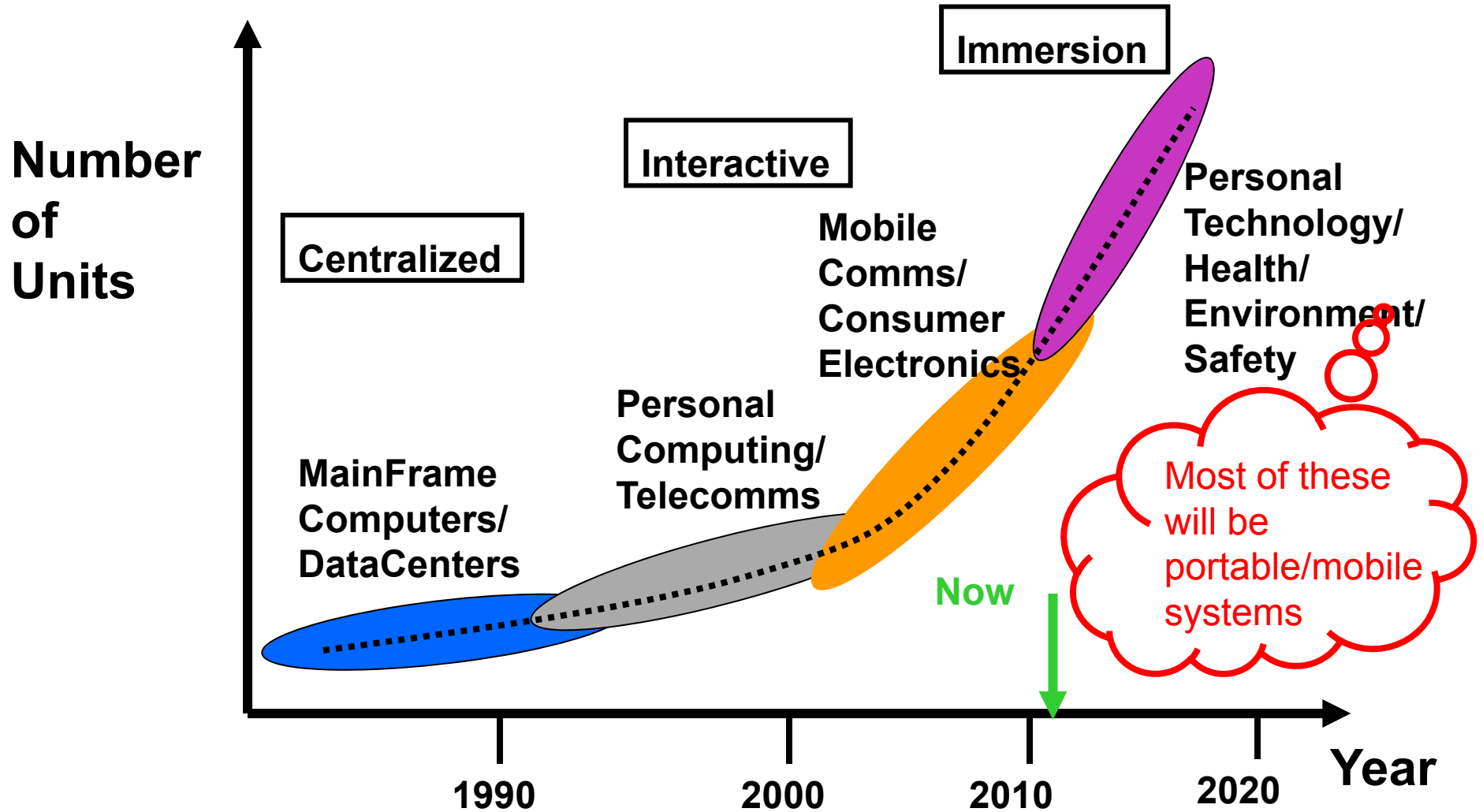

# 10x to 100x Increase in Units

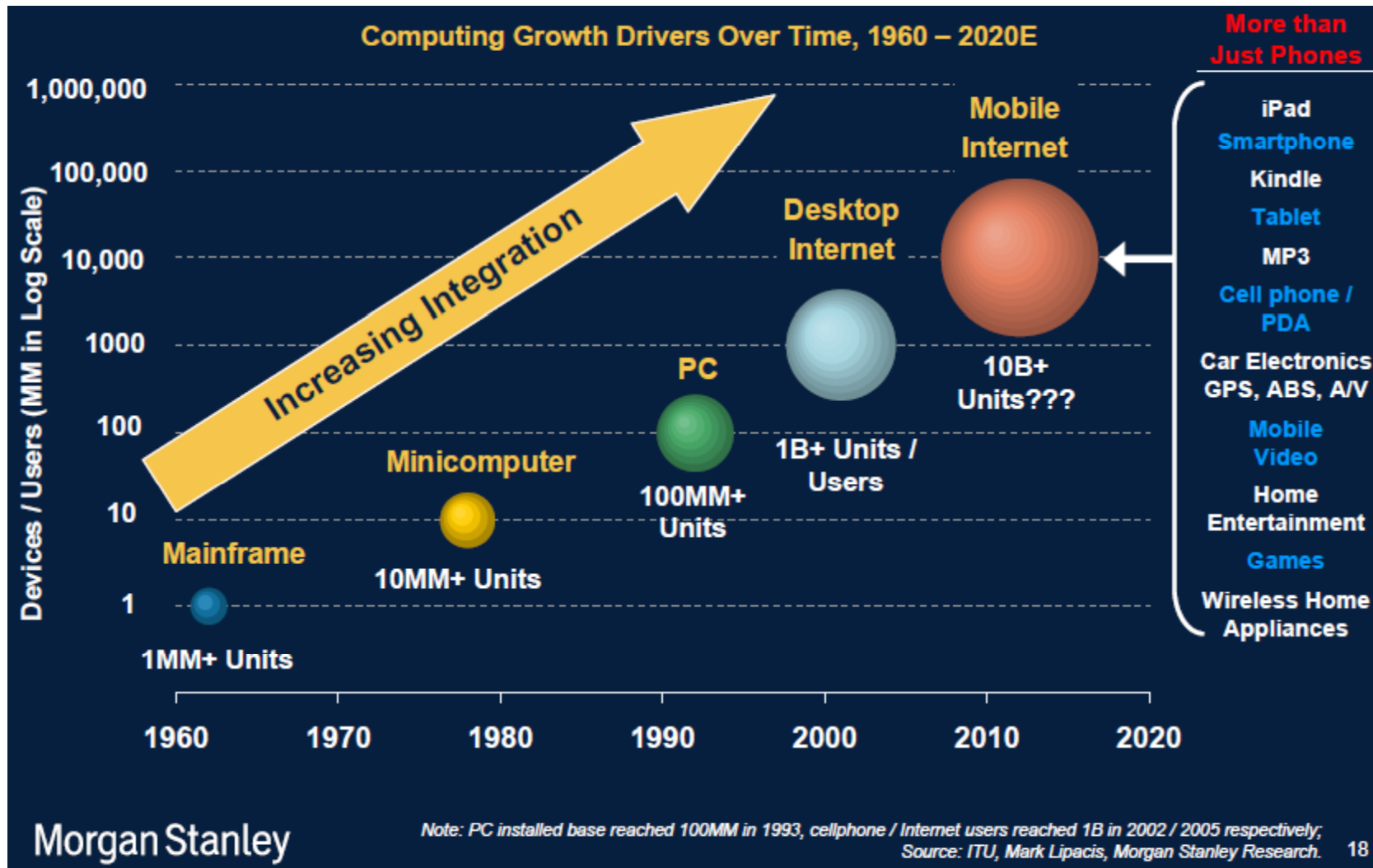

## .....But Cost is Important

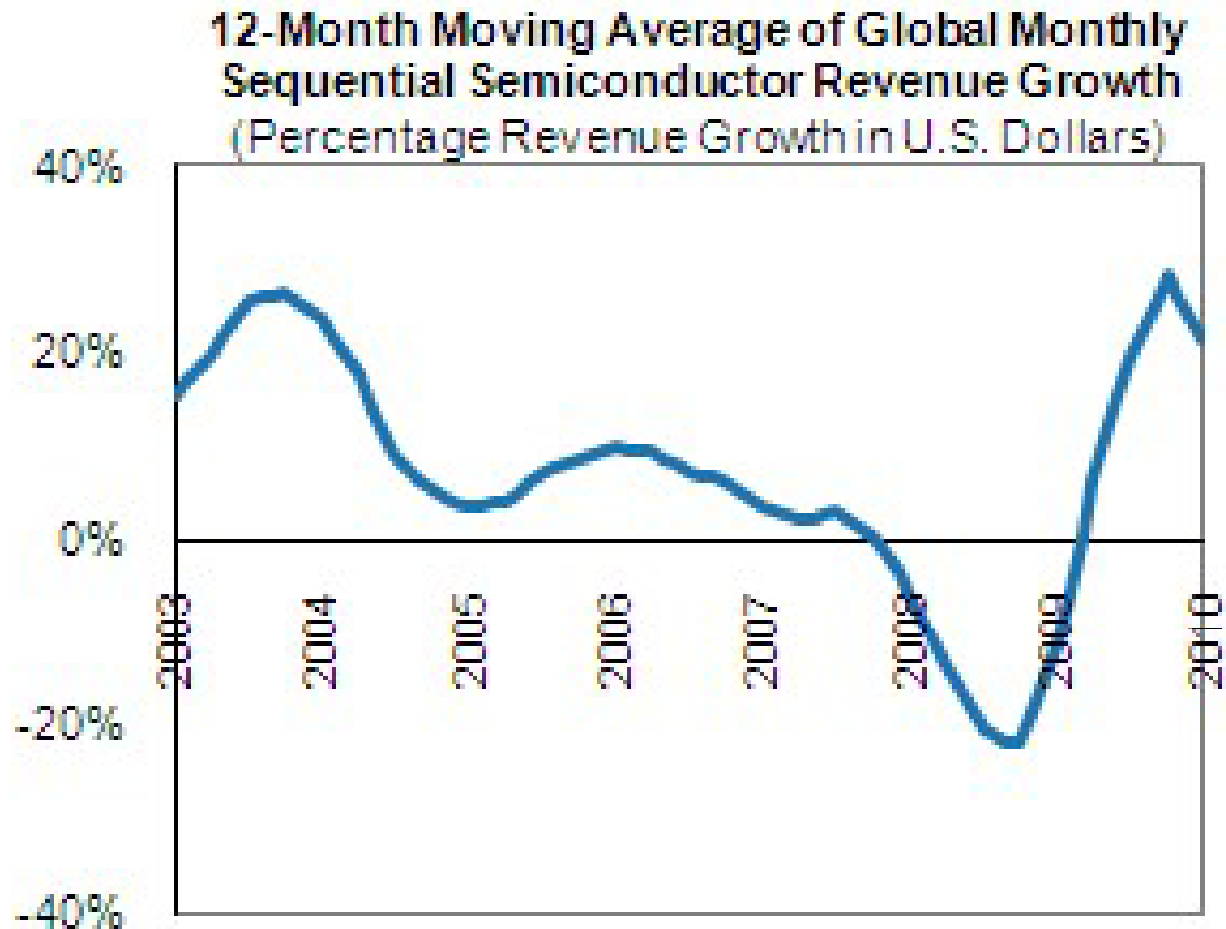

Source: iSuppli

- Semiconductor Revenue grows at <10%/year on average.
- Low cost solutions are critical to growth.

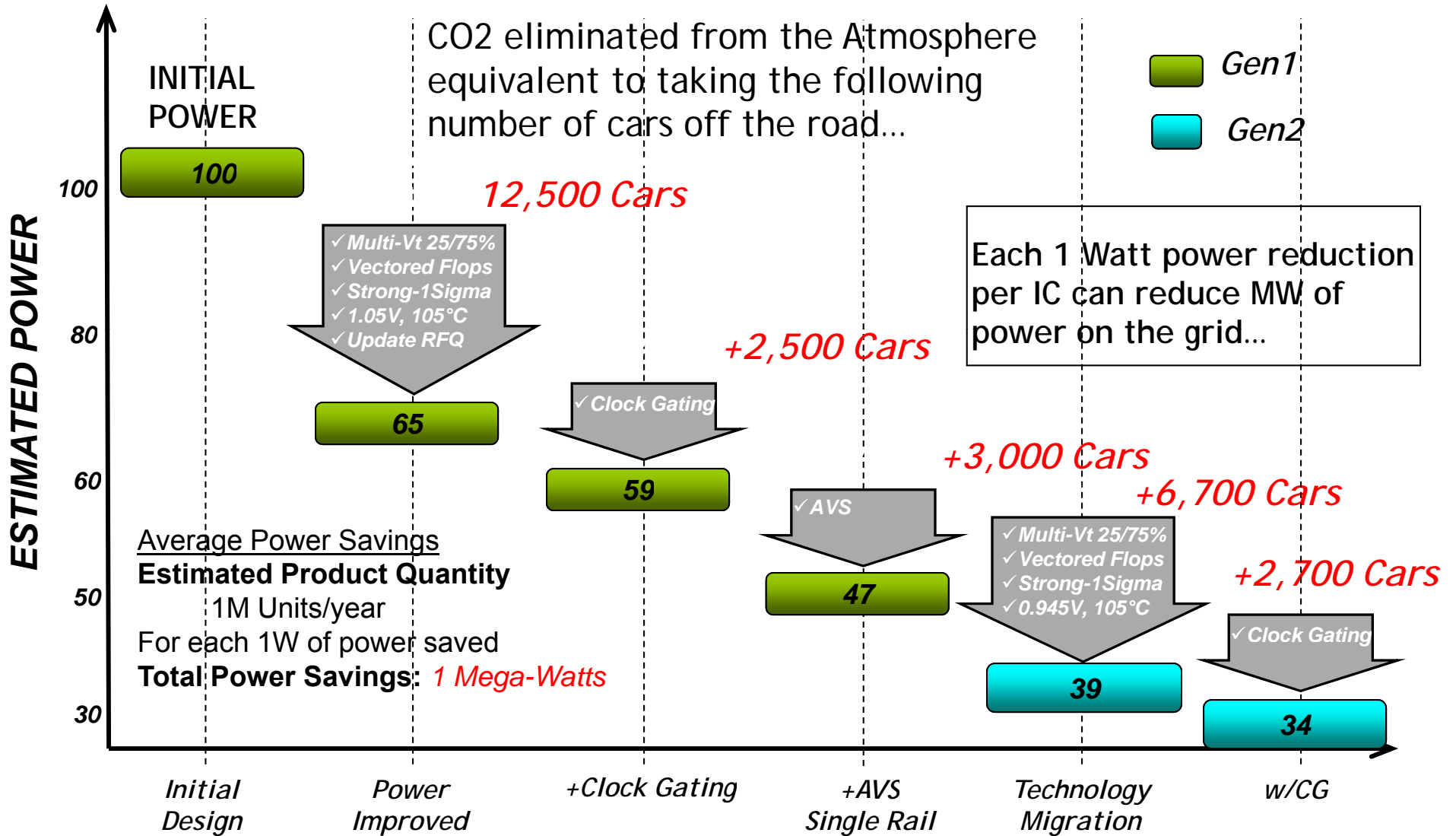

# Reducing Chip Power Has Big Impact



# Wireless?

[EE Times: Latest News](#)  
**Wireless is everywhere; ignore it at your peril**

[Bolaji Ojo](#)  
Page 1 of 2  
[EE Times](#)  
(01/07/2008 9:00 AM EST)

 PRINT THIS STORY  
 SEND AS EMAIL  
 REPRINTS

The search is over for the next killer app. It is wireless, it is all around you, and it will leave no sector of the global economy untouched.

Growth of Wireless to  
Continue  
Unabatedly!

EE Times,  
January 07, 2008

- 5 Billion people to be connected by 2015  
(Source: NSN)
- 7 trillion wireless devices serving 7 billion people in 2017 (Source: WWRF)
  - 1000 wireless devices per person?

# THE IT PLATFORM OF THE NEXT DECADE(S)

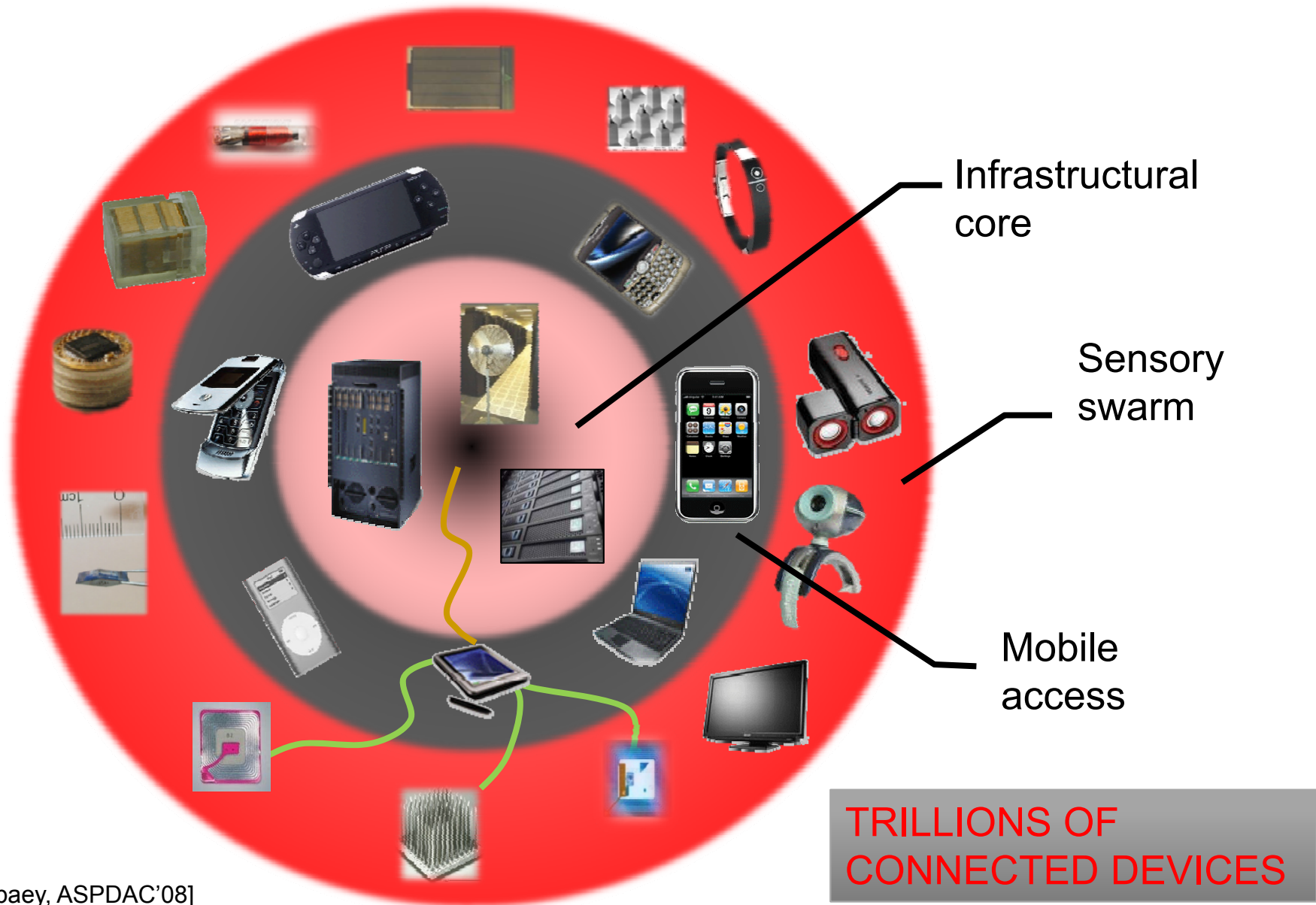



***WHAT DO WE NEED?***

# Life in the Future

From back in the 60's!!



## Techno-Optimism

- Man on the Moon
- Concorde and Jumbo Jets
- Electric Music, Video, Cassettes
- etc.....

But.....major limitations to the Jetson's World

- Power, Cost, size

What does it take?

- Wireless Networks
- Low Power Circuits
- Sensors
- Human Machine Interfaces
- Energy Harvesting
- RF/Analog
- High speed Data Communication
- Data Analysis

# Energy Generation and Management

- **Major limitation for expansion of the application space for semiconductors**
  - Intelligent environment requires wireless and autonomous systems that can operate for approximately 10 years.
  - Two types of portable electronics:
    - Performance “hub” devices such as computers, multi-media devices, wireless hubs and PDAs which have 1W to 5W needs today.
    - Distributed systems with micro and nano watt needs.
- **Typical autonomous system would be:**
  - 10 years life.
  - Battery size/cost point is  $\sim 1\text{mAh}$ .
  - Average power available from battery  $< 1\text{nW}$ .

# Battery Technology Is Trailing Demand

- Battery technology scaling at about 2x every 10 years compared to semiconductor technology at 2x every 18 months.

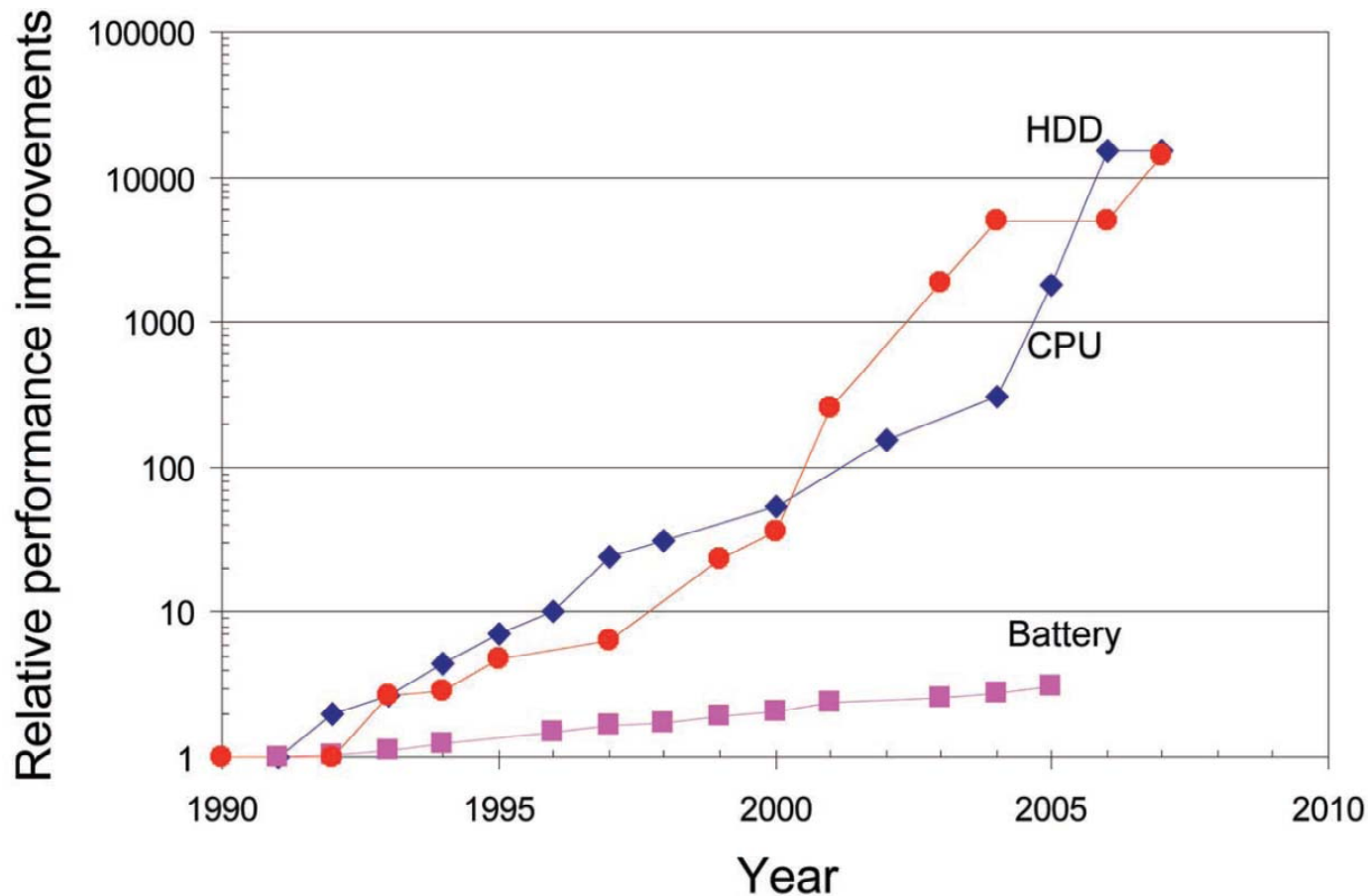

Ref: Chalamal,  
Proc. IEEE, 2007

# Power Management Techniques

	Dynamic Power Reduction <sup>1</sup>	Leakage Power Reduction <sup>1</sup>
Multi-VT and Multi-L	Varies	34%/~7x
Clock Gating	~12% - 30%	Varies
Memory PM Modes	~2x	3-30x
Voltage Islands	CV <sup>2</sup> F	~1.5x
Adaptive Voltage Scaling Static (Open Loop)	~9-15%	~10% -27%
Adaptive Voltage Scaling Dynamic (Closed Loop)	~10-19%	~15%-50%
Optimized IP	Varies	Varies
Power Islands	NA	~20-100x
Dynamic Voltage and Frequency Scaling (DVFS)	Varies	Varies

<sup>1</sup> Figure of Merit, Impact is design dependent

# Energy gap of a mobile device

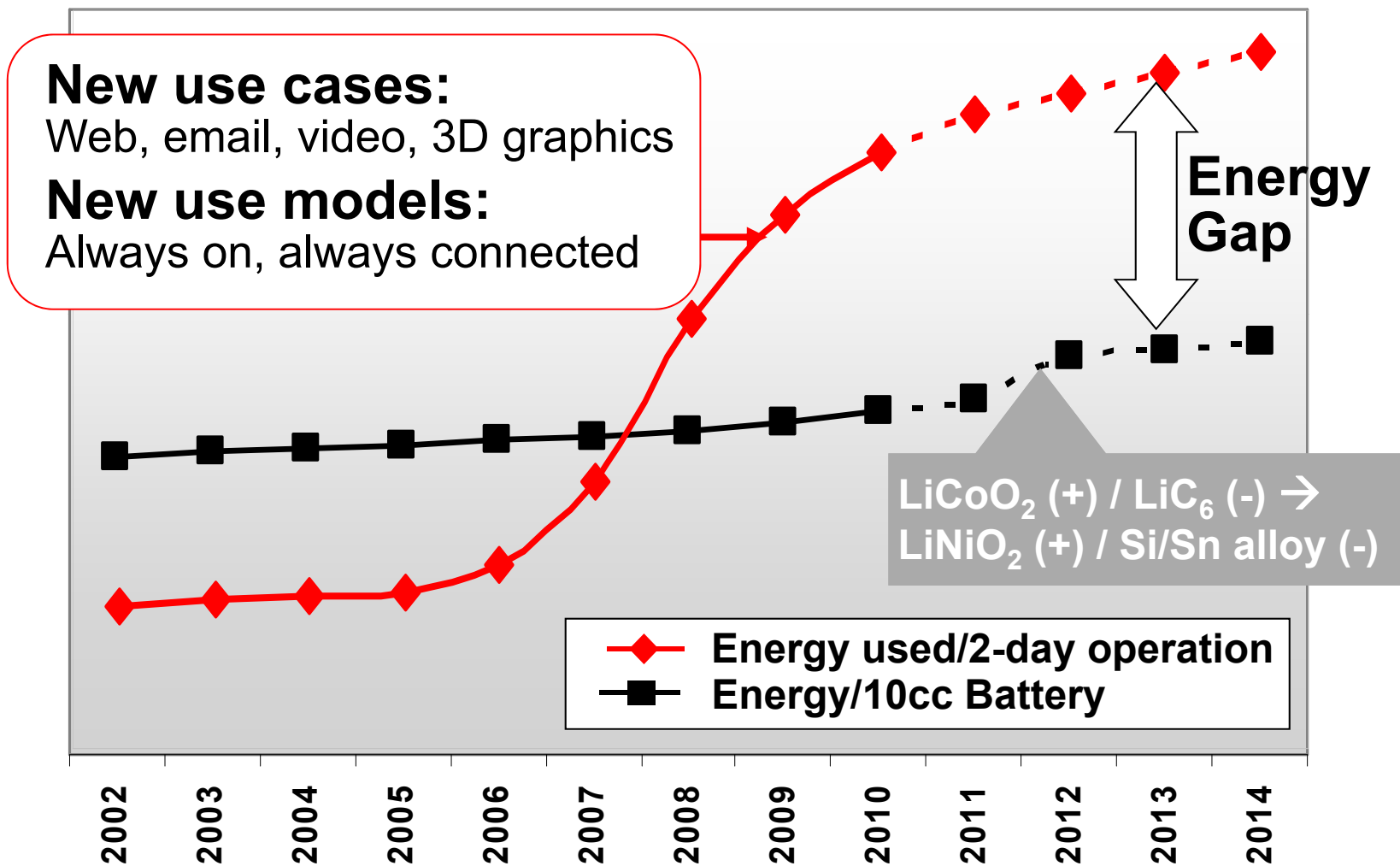

Source: Öfversten [IWPC'08], Samms [IWPC'08]

Delagi, ISSCC10

# Silicon performance advances require power management

Delagi, ISSCC10

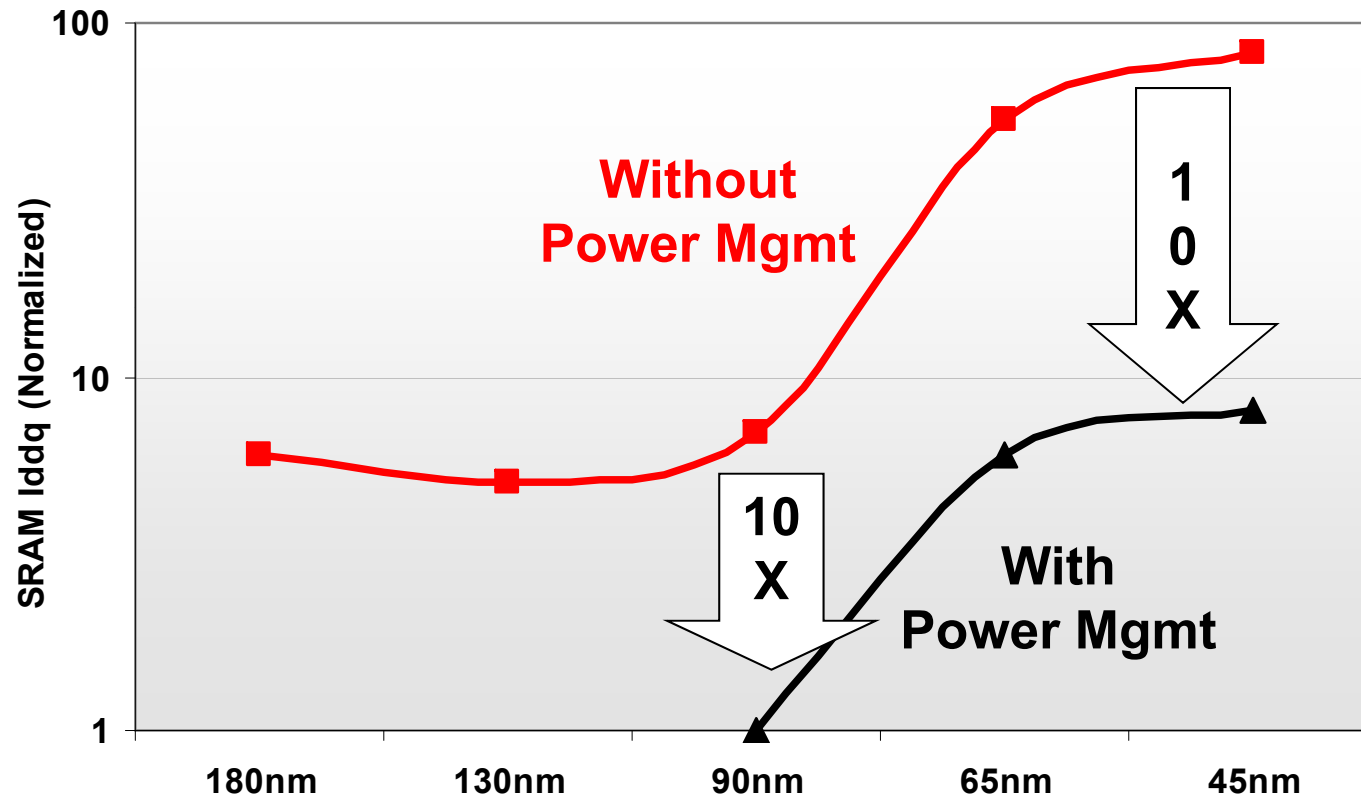

Source:  
Gammie [ISSCC'08]

- Performance: +20~30% node-to-node
- Leakage: a concern in 90nm, required fundamental change in 65nm

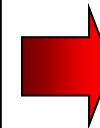

Circuit-level  
power mgmt

# Industry breakthrough examples (published)

- Power & performance management technology
- Reduces both leakage and active power, increases performance

## 65nm leakage power reduction: 300X

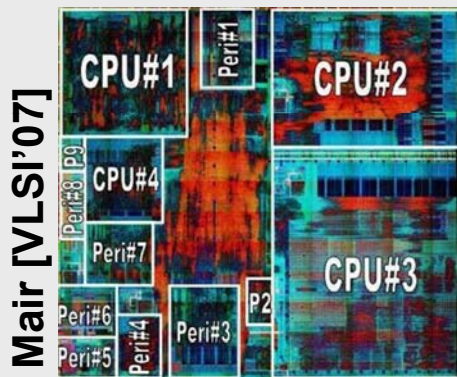

- SRAM retention
- Logic power gate
- Channel length
- Logic retention
- Process/temp AVS
- DVFS

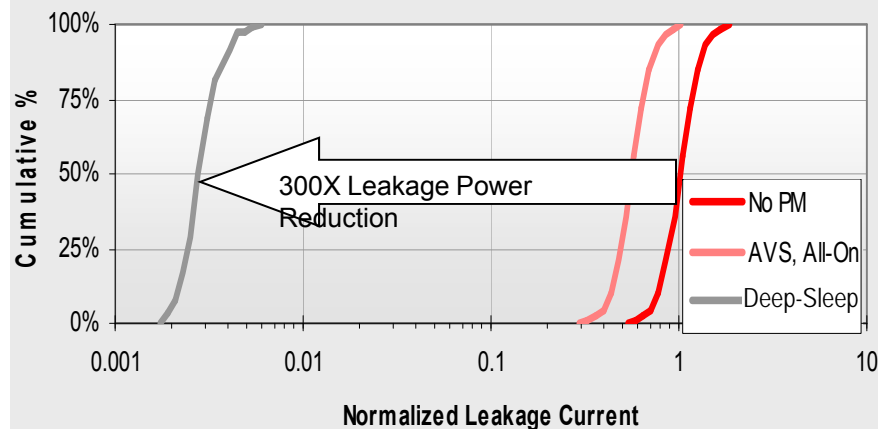

## 45nm active power reduction: 1000X

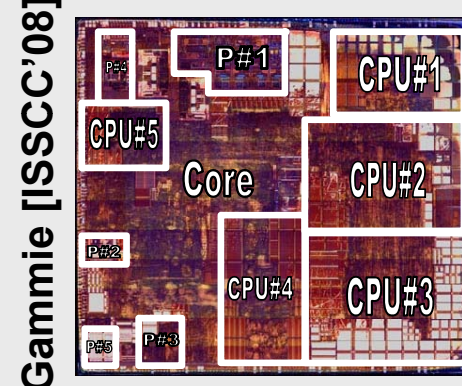

- Adaptive Body Bias (ABB) for performance & power
- Retention 'Til Access (RTA)

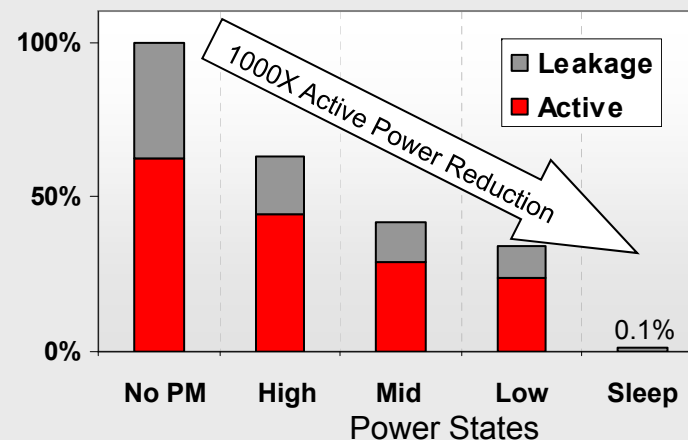



# Directions in ultra-low power

Ultra-low power video codec

Source: JSSC Nov 2009

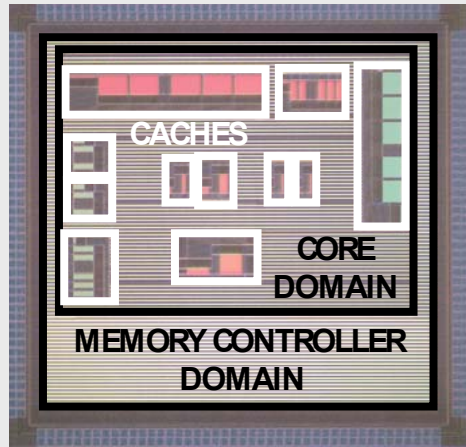

Video decoding for  $< 2 \text{ mW}$  at  $V_{dd} = 0.7\text{V}$

Ultra-low power medical processor

Source: ISSCC 2008

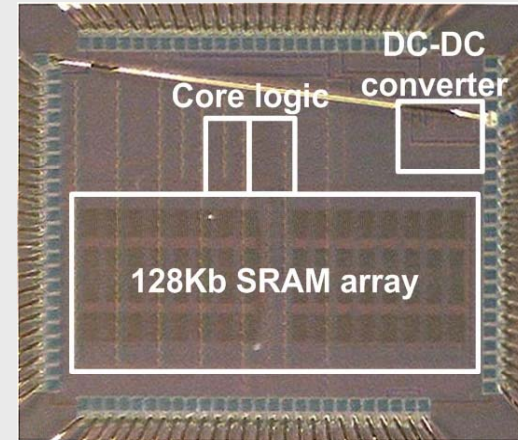

MSP430  $\mu\text{C}$  with SRAM at  $V_{dd} = 0.3\text{V}$

Ultra-low power DC-DC converter

Source: MIT research

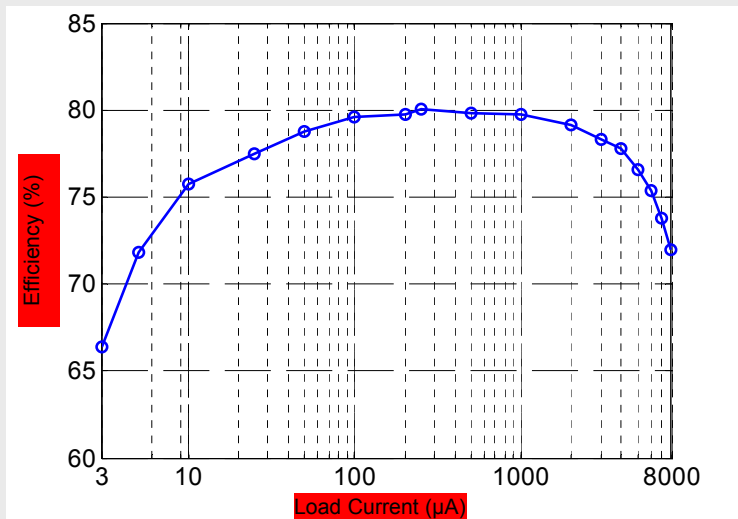

DC-DC with 75% efficiency down to 10  $\mu\text{A}$

Energy scavenging

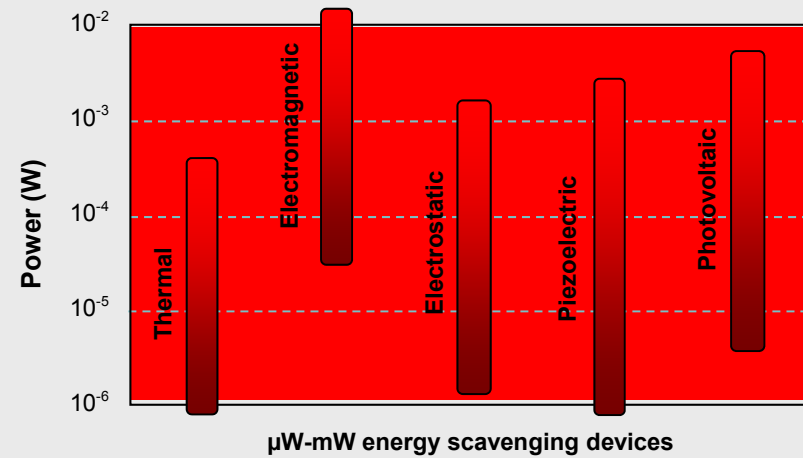

Scavenging energy from the environment

# ***Next Steps in Low Power Electronics***

# Ultra Low Power Chip Design

## Typical Design for Intelligent Ambient Applications

1mA-Hr Battery for 10 years

1uA average power budget

**<1uA** average for digital system

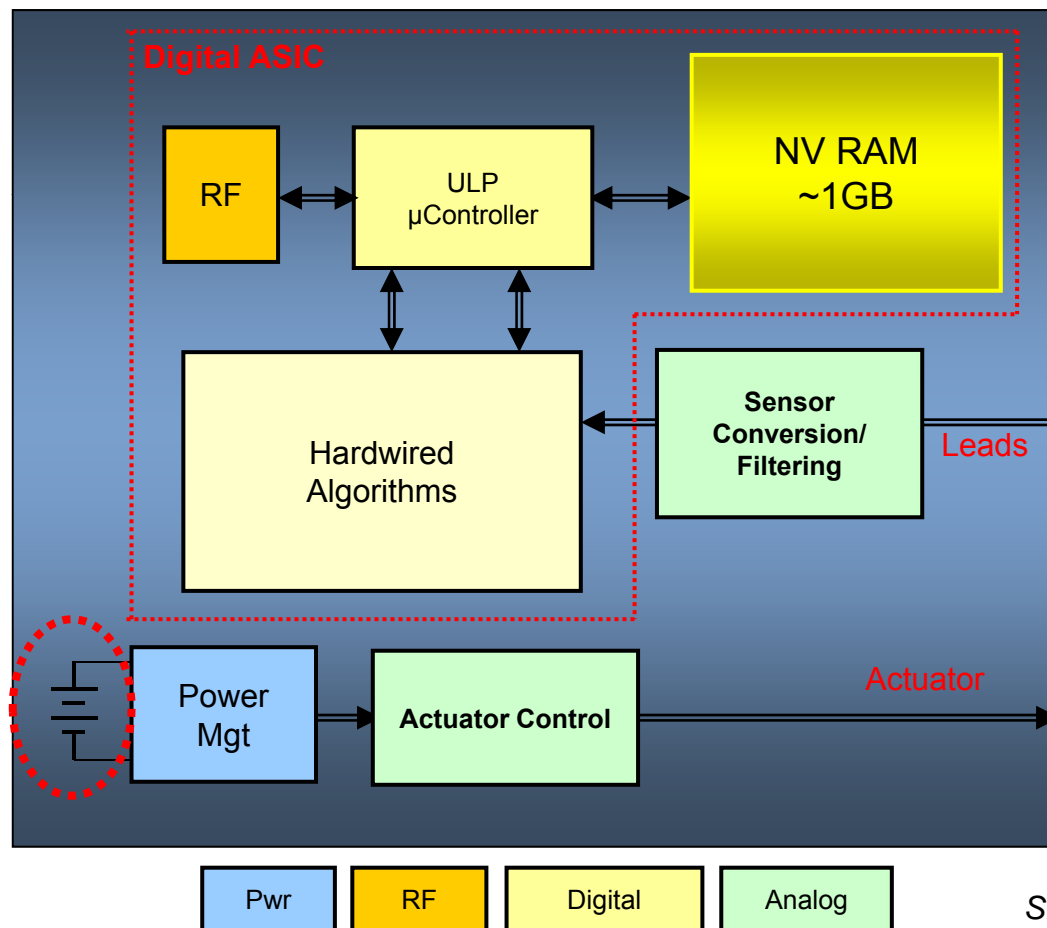

- Use circuit design techniques for optimizing energy-performance

- Then apply system design and software management to reduce power by another order of magnitude

# Battery Technology is Critical

- **Li-Ion was the game-changer for the 2000's.**
  - In 1990s nickel cadmium and nickel metalhydride rechargeable batteries were the preferred energy technology
  - In last 10 years, lithium batteries have taken over with a current market share of over 70%.
  - lithium cell is its high energy density, => small size, lightweight, longer lifespan than comparable battery technologies.
  - Also, high power, high-energy efficiency, low self-discharge, and good cycle life. Specific energy densities greater than 190 Wh/kg.
  - But now approaching its limit with small incremental gains
- ***We need the next breakthrough in energy delivery for the 2020s!!***
  - Capacity, Cycles, Rate, are critical parameters.

# Renewable Energy

- Renewable Energy Has Tremendous Potential
- Solar energy products
  - Photovoltaic systems
  - DC/AC power inverters
- Wind energy products
  - Wind turbines
- Hydro energy products
- Heating systems

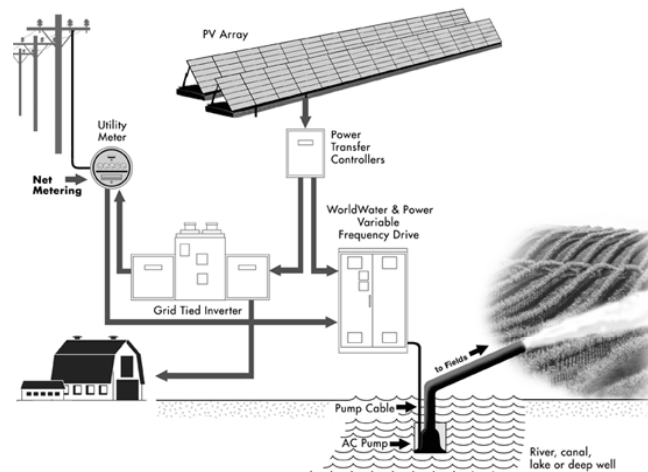

# Energy Harvesting

- Vibrational, thermal, photovoltaic, RF power have been proposed.
  - Harvest energy from motion, heat, light and RF.
  - Great for triggering imagination.
- But micro and nano ampere power levels are very inefficient.
- Laws of conservation usually apply
  - Inserting a harvester can increase the energy usage by the generating system.

***Need a lot more understanding to appreciate trade-offs and practical solutions.***

*Economist, March 2010*

20 Heat scavenging

The Economist Technology Quarterly March 6th 2010

## Stealing the heat

Energy: The idea of recycling paper, glass, metal and plastics has become commonplace. New technologies allow heat to be recycled, too

“WATER, water everywhere, nor any drop to drink,” lamented the becalmed Ancient Mariner. Oddly, the same is true of energy. As with the water that surrounds a desert island, there is abundant energy right under people’s noses, in the form of wind, sun, tides and heat. The trouble is that like saltwater none of these

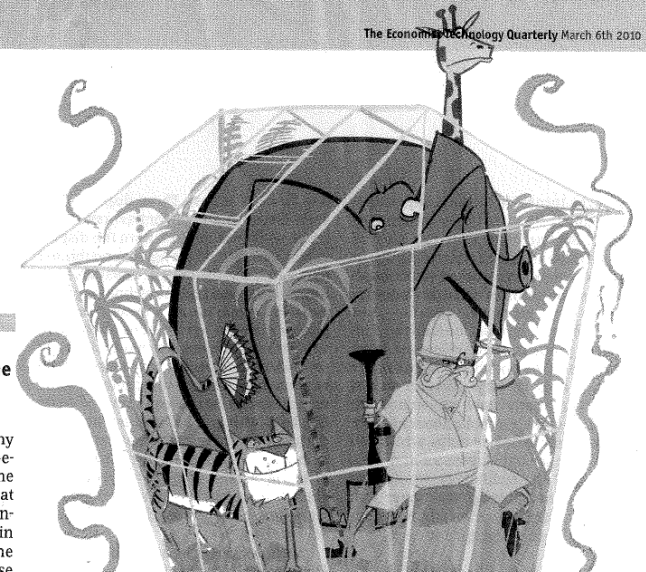

STARTUP TO WATCH

## nPower Makes Battery Charging a Walk in the Park



By Jack M. Germain  
TechNewsWorld  
01/05/10 11:05 AM PT

[Print Version](#)  
[E-Mail Article](#)  
[Reprints](#)

The idea behind Tremont Electric's nPower PEG technology is to harness the kinetic energy you

[guardian.co.uk](http://guardian.co.uk)

[News](#) | [Sport](#) | [Comment](#) | [Culture](#) | [Business](#) | [Money](#) | [Life & sty](#)

[Environment](#)

## Nokia developing phone that recharges itself without mains electricity

Prototype harvests radiowaves from TV, radio and other mobiles  
~ 5mW from 1000 energy sources.

# Energy Scavenging Efficiencies

Energy Source	Characteristics	Efficiency	Harvested Power
Light	Outdoor	10~24%	100 mW/cm <sup>2</sup>
	Indoor		100 μW/cm <sup>2</sup>
Thermal	Human	~0.1%	60 μW/cm <sup>2</sup>
	Industrial	~3%	~1-10 mW/cm <sup>2</sup>
Vibration	~Hz–human	25~50%	~4 μW/cm <sup>3</sup>
	~kHz–machines		~800 μW/cm <sup>3</sup>
Embedded Energy	Chemical	~90+%	~90+%
	Radioactive	~30%	~1- 20 μW/cm <sup>3</sup>
RF	GSM 900 MHz	~50%	0.1 μW/cm <sup>2</sup>
	WiFi		0.001 μW/cm <sup>2</sup>

⇒ Need to look at non-traditional areas for scavenging energy. What else do we have?

⇒ Energy generation using biological, micro-fuel cells, etc.

# Mobile Internet System

- **A distributed computer system**
  - The internet of things – **THE SWARM**
- **Use multiple energy sources**
  - Battery for general functionality
    - energy management and control, wake-up functions, etc.
  - Storage caps for high current functions
    - storage, communications
  - Energy scavenging for extended battery life
  - Wireless power sources for connection to grid
    - Directional use of RF, light, etc. in localized area for “topping up”.
- **Intelligent energy management and control**
  - Highly efficient on-chip power processing
  - Control of energy sources and delivery
  - Management of power demand and access
  - Unreliable energy sources

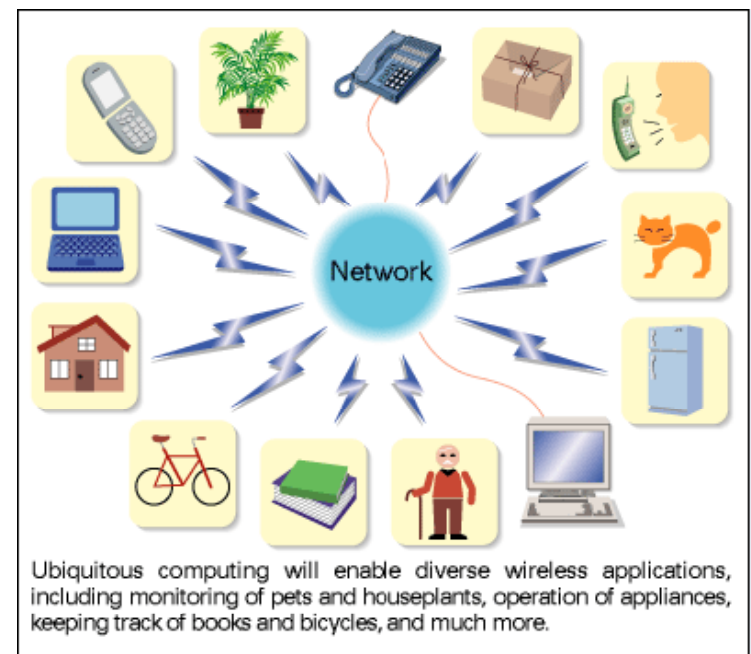

**Ubiquitous Computing**



# KEY CHALLENGES

# Challenges for Next Decade - 1

- **Low-Power Electronic Design**
  - Need another two to three orders of magnitude of power reduction.
  - Most known circuit design approaches have been utilized
  - System-level power optimization is needed
  - Can the process technology help? Not just digital any more.
- **System Design**
  - Managing interconnectivity: wireless and network connectivity; protocols are expensive in power and complexity
  - Partitioning for power optimization
  - Security
- **Low-Power Sensor Technology**
  - The intelligent environment requires a wide range of high performance sensors
  - Sensor interface and control needs to become sophisticated

# Challenges for Next Decade - 2

- **Battery and Storage Technology**
  - We need micropower and nanopower battery capability
  - Nanotechnology can provide some of the solutions
  - Smart Batteries, intelligent power management
- **Energy Scavenging**
  - Truly scavenged from waste
  - Efficiency in collection and storage.
  - We need more work in understanding availability, applicability, and harvest/storage.
- **Off-grid power distribution**
  - Local wireless power to storage elements
  - Sense and deliver on-demand
  - Connecting to the grid

# **CHANGING PARADIGM**

# Optimizing the system requires collaboration and co-design

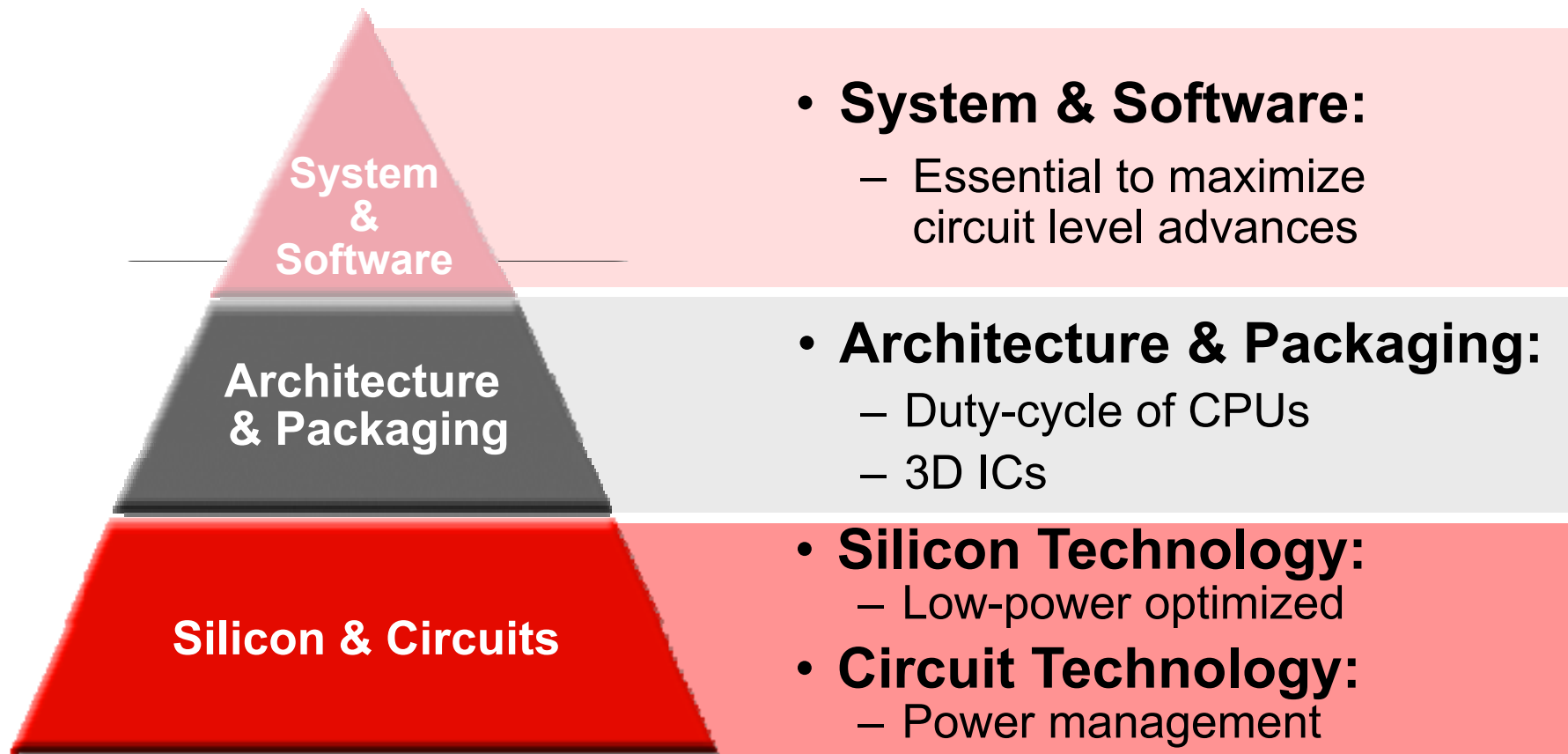

# CONCLUSIONS

# Concluding Reflections

- We are on the threshold of a new wave of electronic technology as we move into the decade.
- Applications driven roadmaps will define what we do.
  - Process technology not driving the roadmap any more
- Ubiquitous intelligence is going to drive wireless connectivity.
- Energy generation and management are critical.
- Low power and cost are key drivers for market growth.
- Close collaboration across all disciplines of electronic engineering from transistors to systems to software.

**THANK YOU!!**

