



Case Study of a High-Speed Distribution Network Reconfiguration Scheme Implementation at PSE&G

Matt Gray, Peter Smith, Mark Johnson, and Steve Blandford

Copyright © SEL 2009

PSE&G "Close-Before-Open" Scheme Eliminates Unnecessary Interruptions



Original Scheme Results in Outages Beyond the Faulted Section

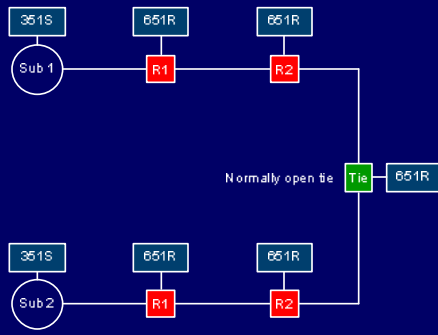

Fault Occurs

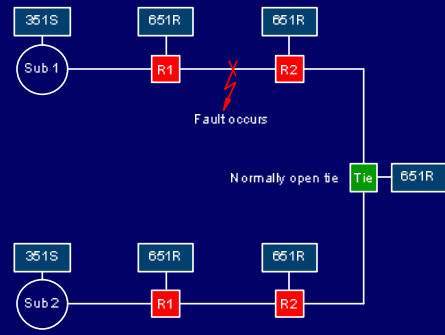

R1 Opens to Clear Fault

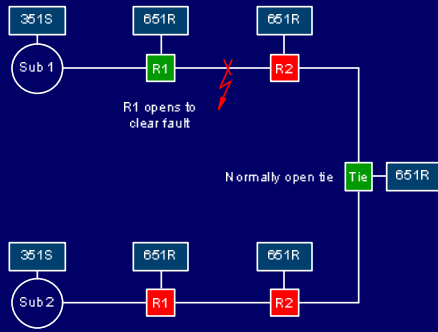

Tie Senses Loss of Voltage

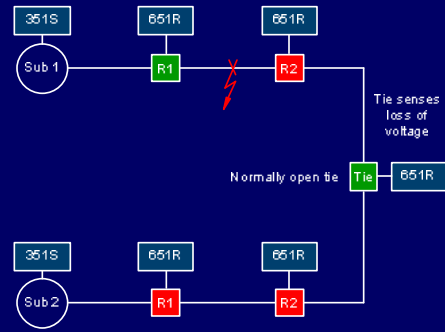

Tie Closes to Restore Service

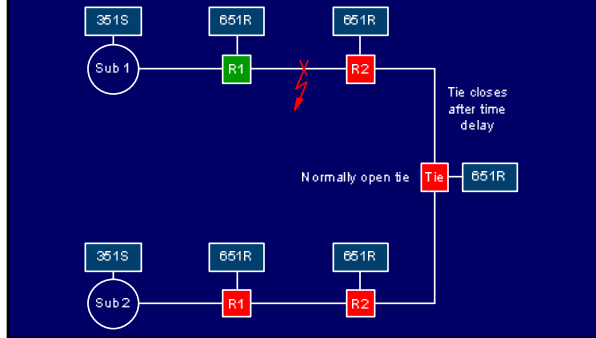

R2 Opens to Complete Sectionalizing

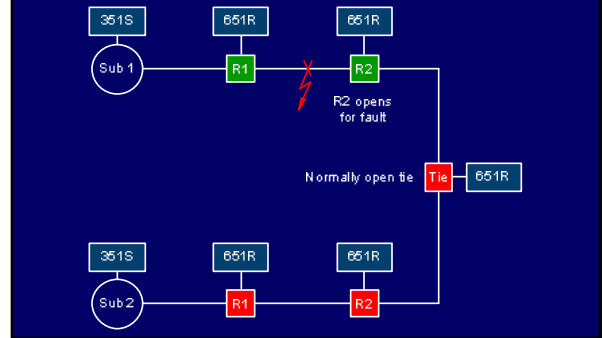

Opportunities to Improve

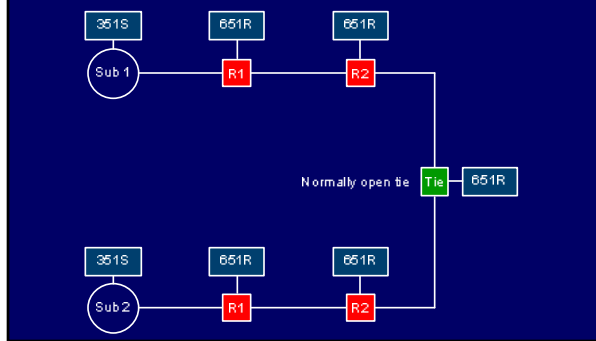

Close Tie Before Clearing Fault to Prevent Unnecessary Interruptions

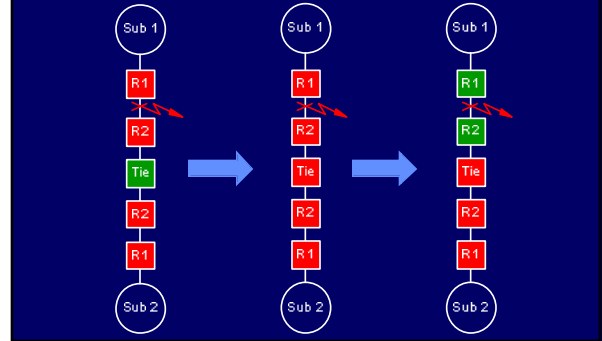

SEL MIRRORED BITS® Communications Is Ready, Willing, and Able

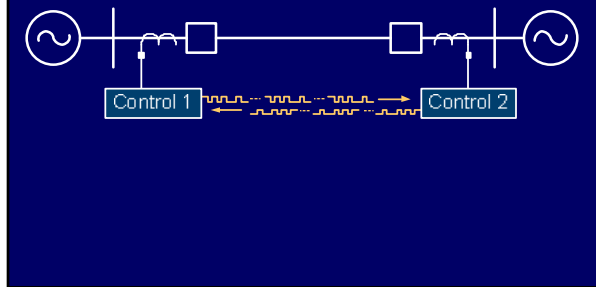

Original Circuit Serves as Starting Point

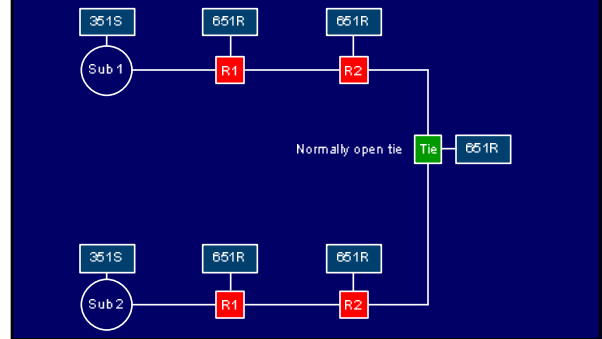

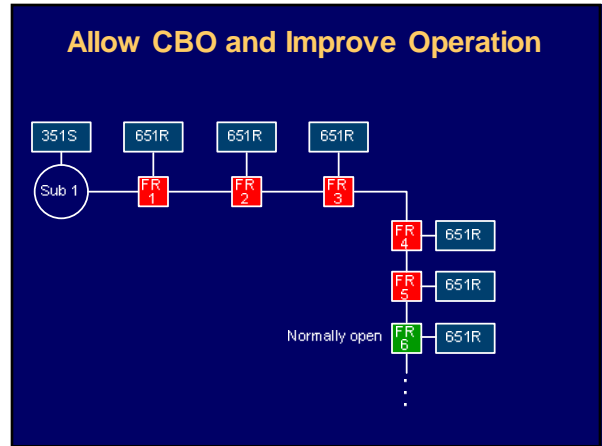
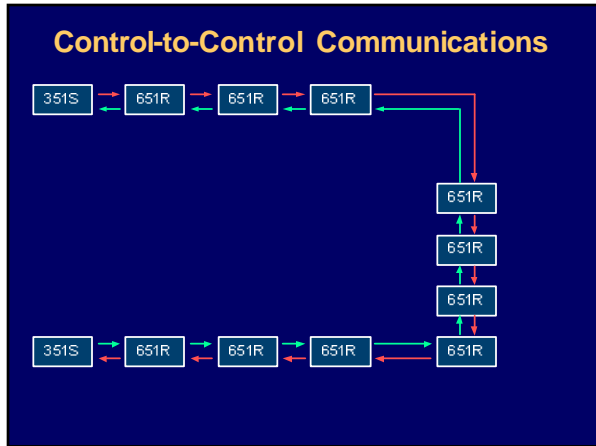
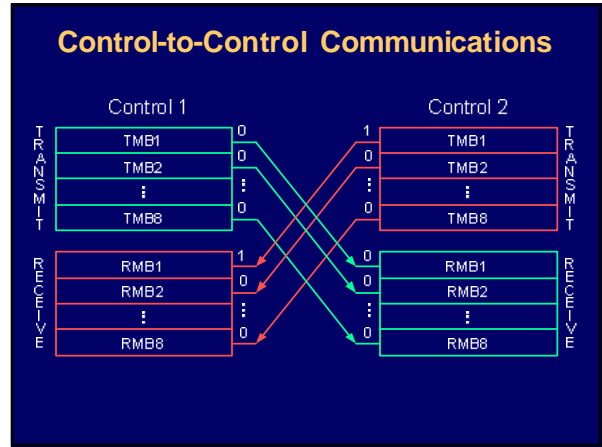
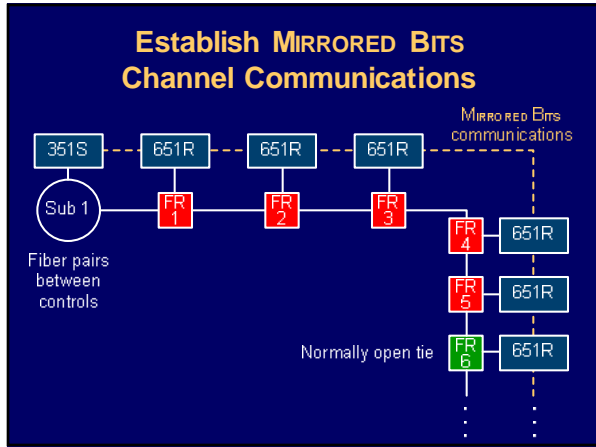
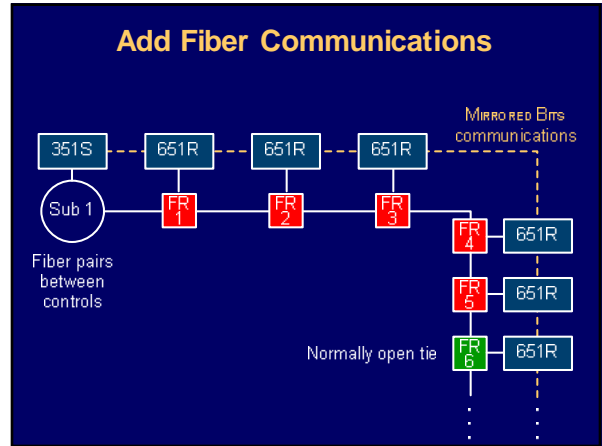
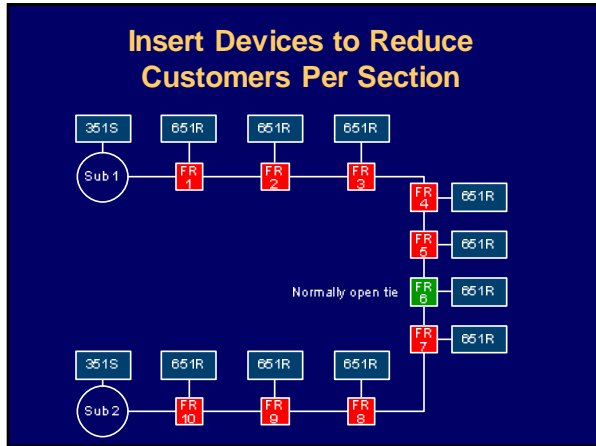

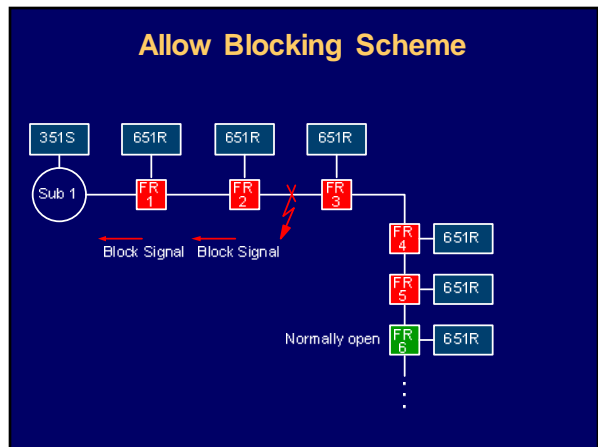
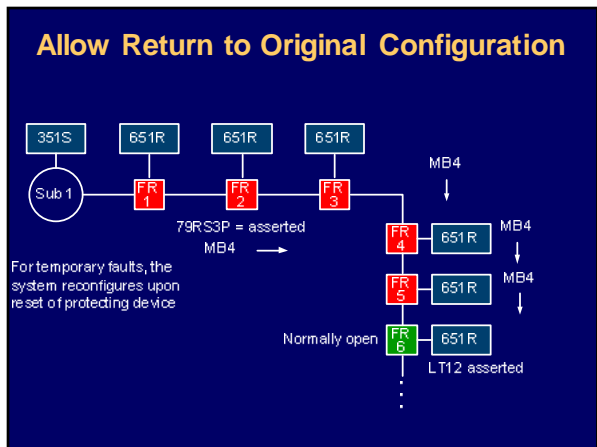
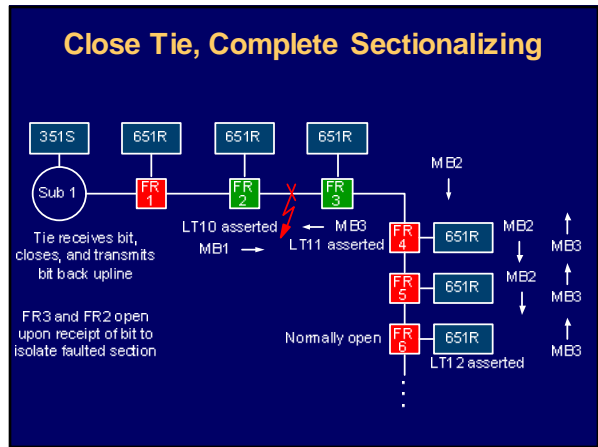
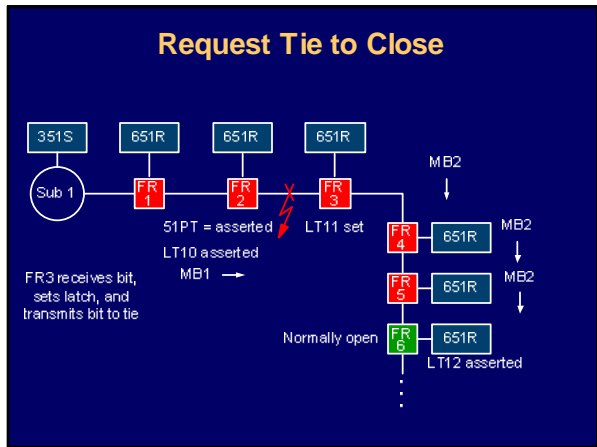
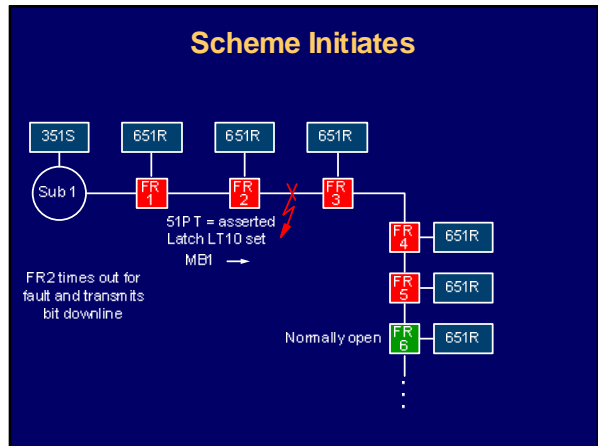
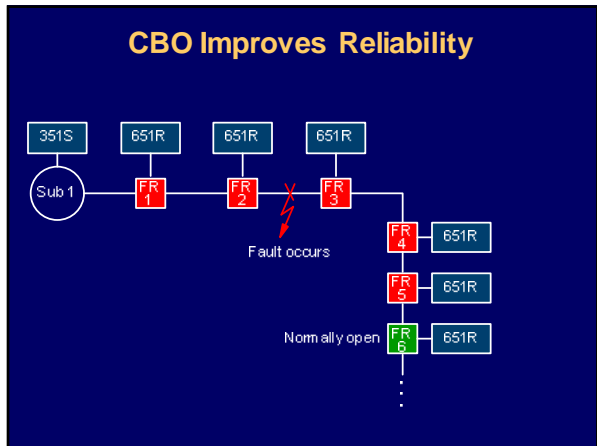

SEL MIRRORED BITS Proves Ideal for CBO

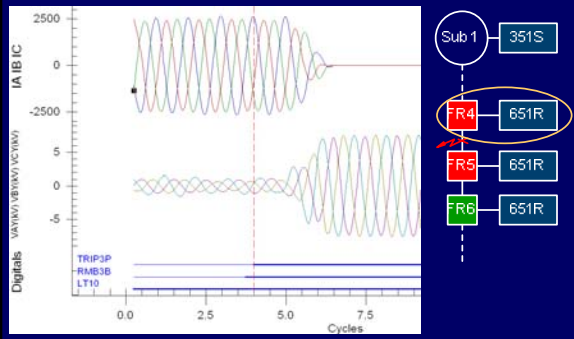

SEL MIRRORED BITS Proves Ideal for CBO

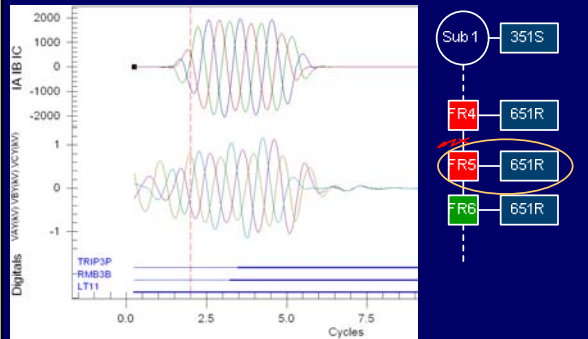

SEL MIRRORED BITS Proves Ideal for CBO

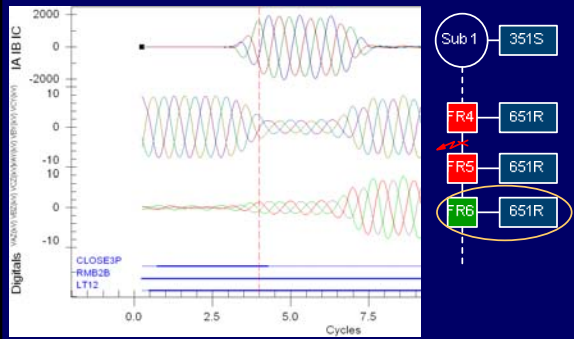

CBO Solution Improves Performance by Reducing Outages to the Minimum

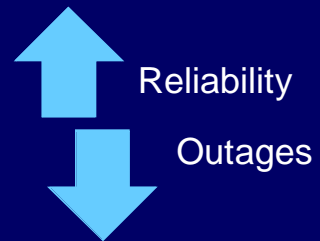

New Scheme Integration

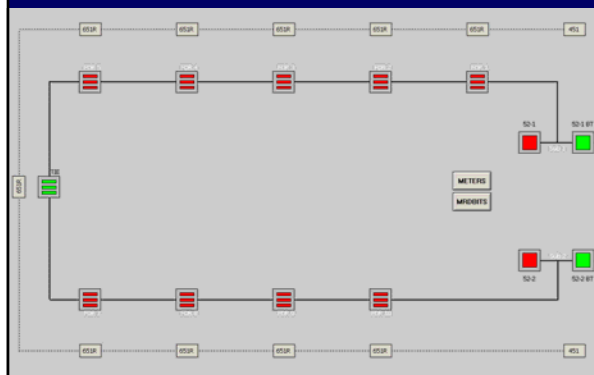

SEL and PSE&G Continue Work to Enhance Operation



