

IEEE Consumer Electronics Society

Calibrating a VR Camera



Adam Rowell
CTO, Lucid VR
adam@lucidcam.com



Virtual Reality Cameras

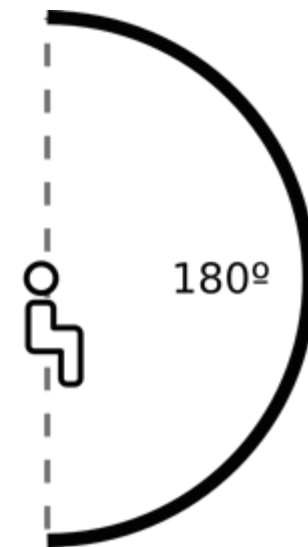

Lucid VR Camera



How Does it Work?

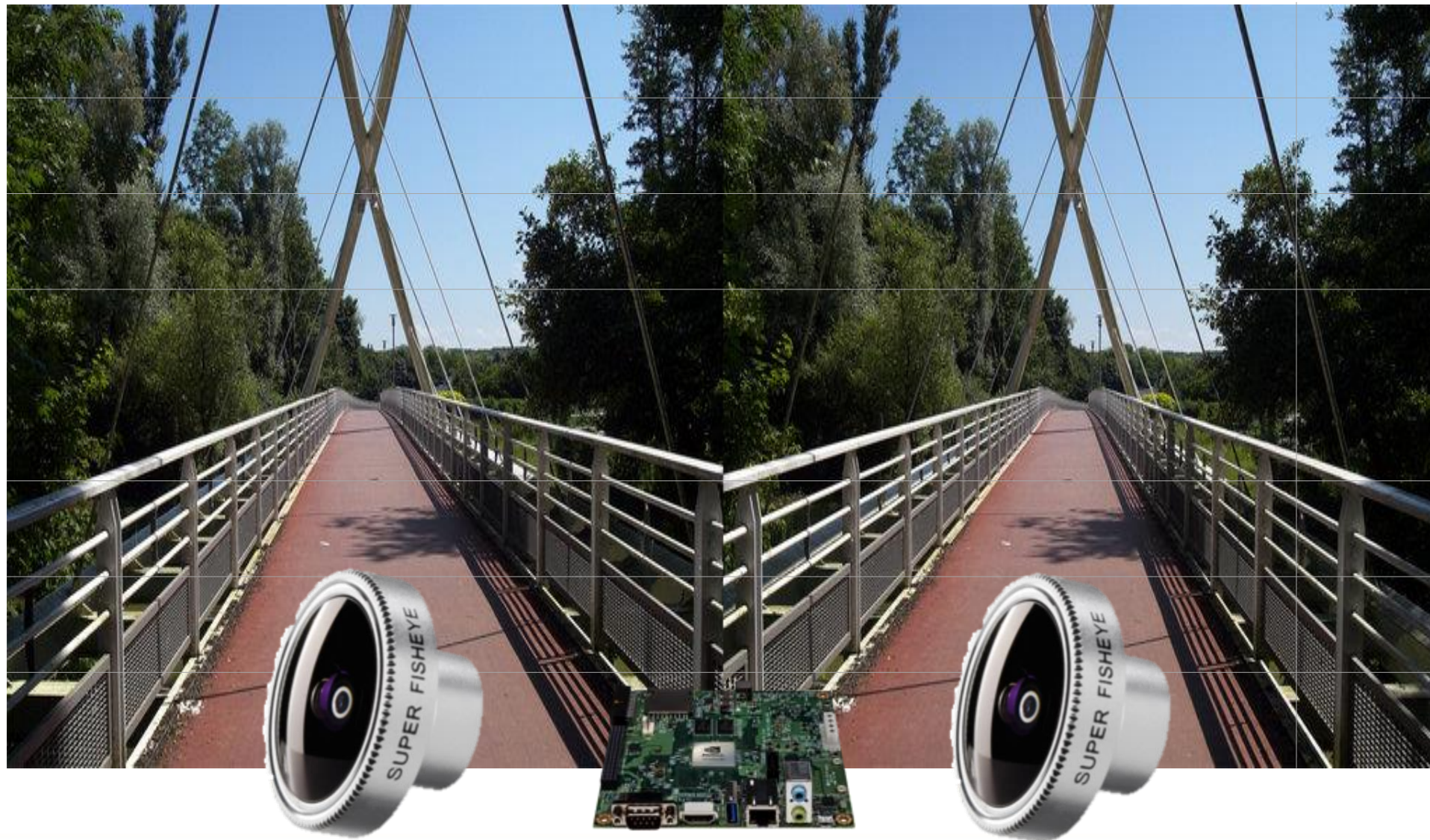

Lucid Software Technology



Recording:

- Synchronization
- Color correction
- Stabilization
- Video encoding
- Streaming



Playback:

- Optimize stabilization
- Color enhancement
- De-warping / rendering
- Add overlays



Post-Processing:

- Video stitching
- Stereo calibration
- Color calibration
- Video editing

How do we transform raw camera frames into great VR video?

STEREOSCOPIC CAMERA CALIBRATION

Stereoscopic Recording & Playback

4K image



4K image



4K x2



(math)

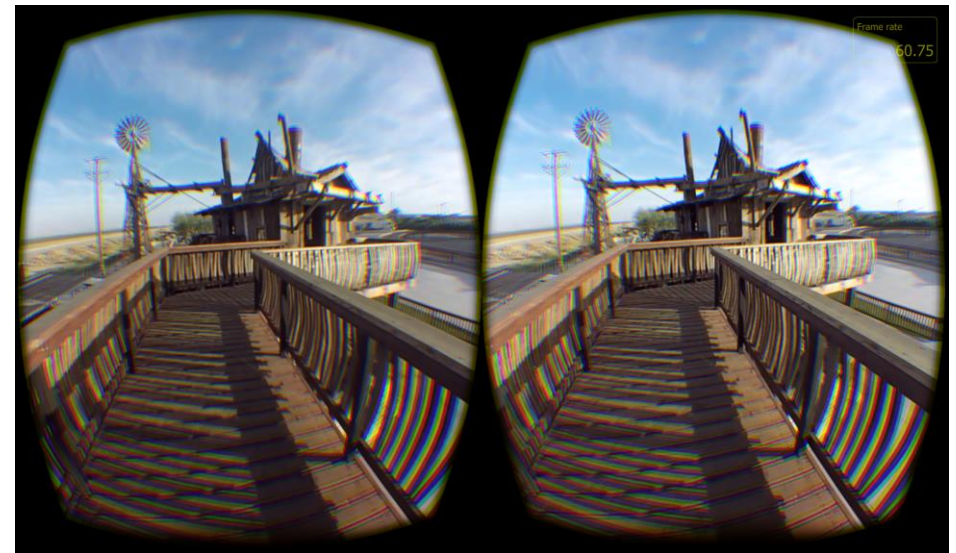

Oculus: 1080x1200 per eye
(2160x1200 total)

Straight Lines Have to be Straight

Calibration fixes the “warping” introduced by the camera lenses



Uncalibrated Video Frame



Calibrated Frame

Fisheye Lenses

The Lucid Camera has two **fish-eye lenses**

Fisheye lenses introduce two main forms of distortion:
Radial and **Tangential**



Radial Lens Distortion

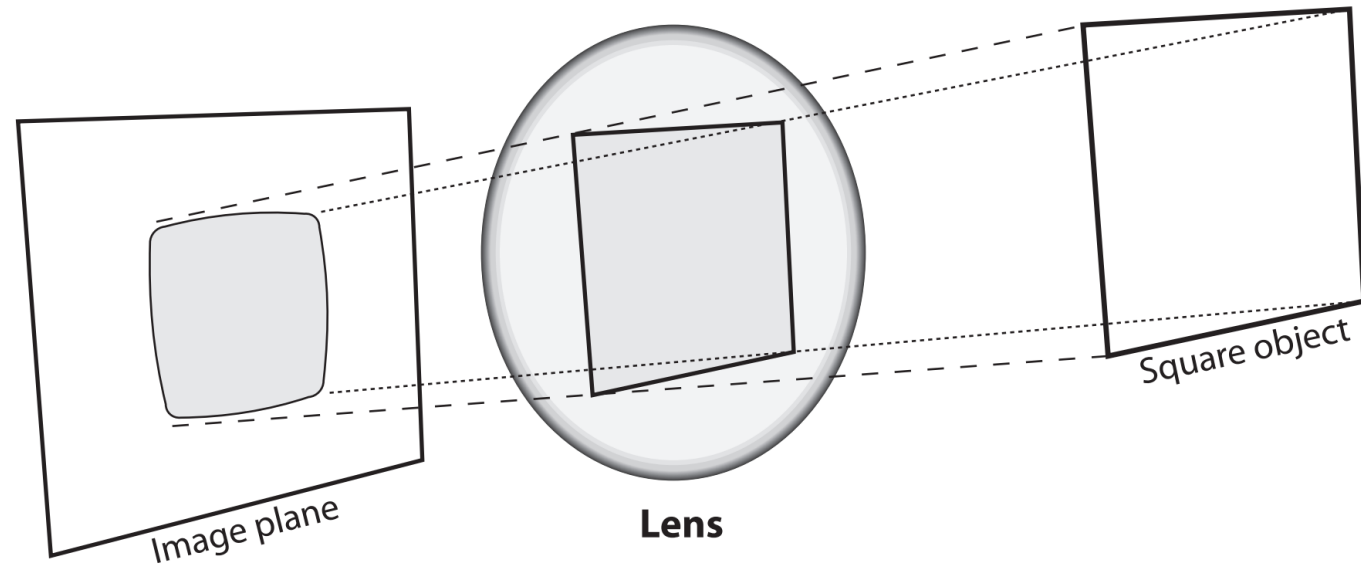

Radial distortion makes straight lines appear **curved**

All lenses have radial distortion – fisheye lenses have extreme radial distortion, especially at the edges

Radial Lens Distortion

The normally straight trees appear to curve around the center of the image

Image is compressed as a function of radius

Calibration will measure the center and strength of the curvature



180° fisheye lens capture

Tangential Distortion

Tangential distortion is caused by tiny differences in angle due to lens mounting. Calibration measures this skewness

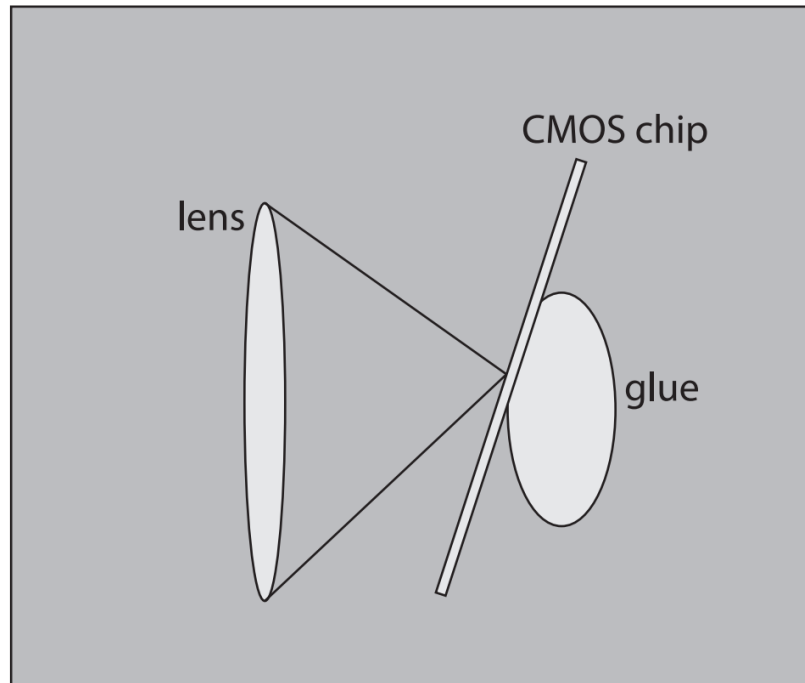

Extreme Example

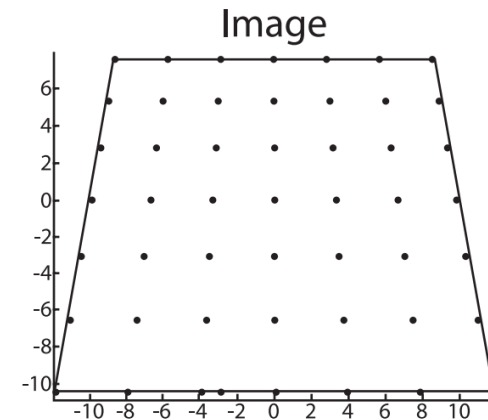

Each camera's calibration parameters may be unique

Stereoscopic Calibration

We also need to align the left and right images to each other

This will correct for any differences in **horizontal, vertical, or rotational disparity** between the two image sensors

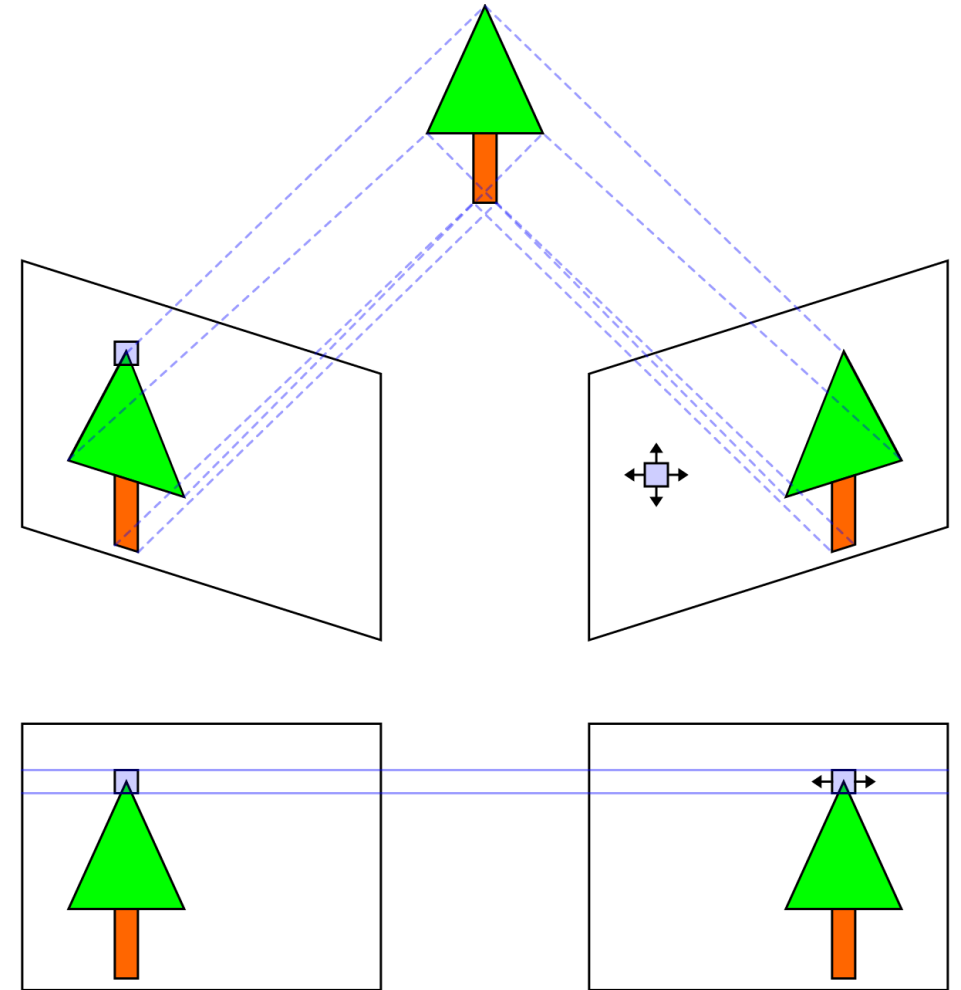
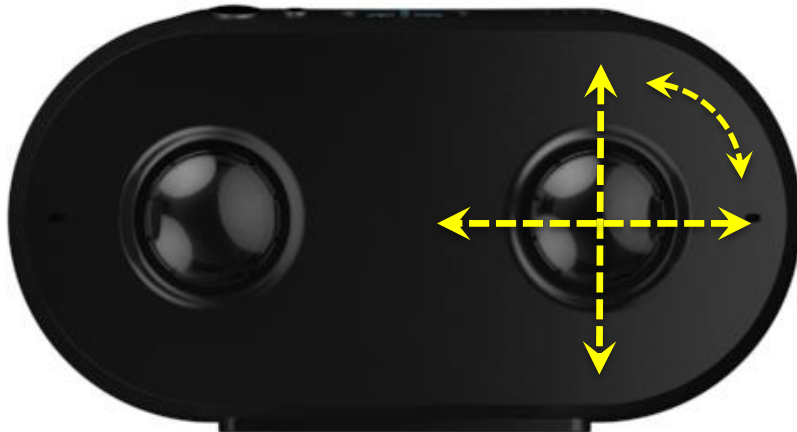

Applying the Calibration

We can apply the calibration in real-time at playback:

1. **Measure VR headset orientation**
2. **For each pixel in the VR headset, determine its latitude/longitude**
3. **Map each VR headset pixel to a point in the raw video frame**
 - Calibration gives us enough information to do this accurately
 - Use radial, tangential, and stereo calibration parameters

This whole process can run on the **GPU** to be really fast

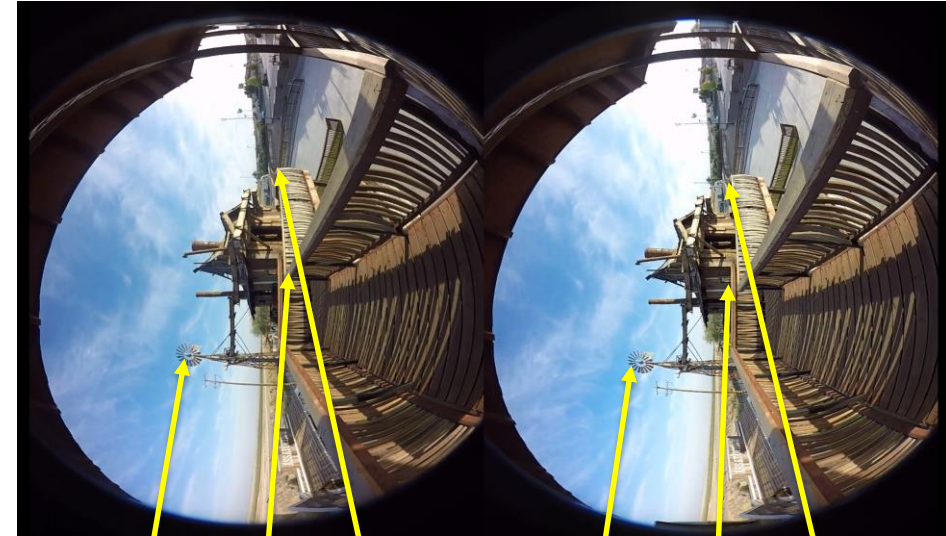

Raw Frame

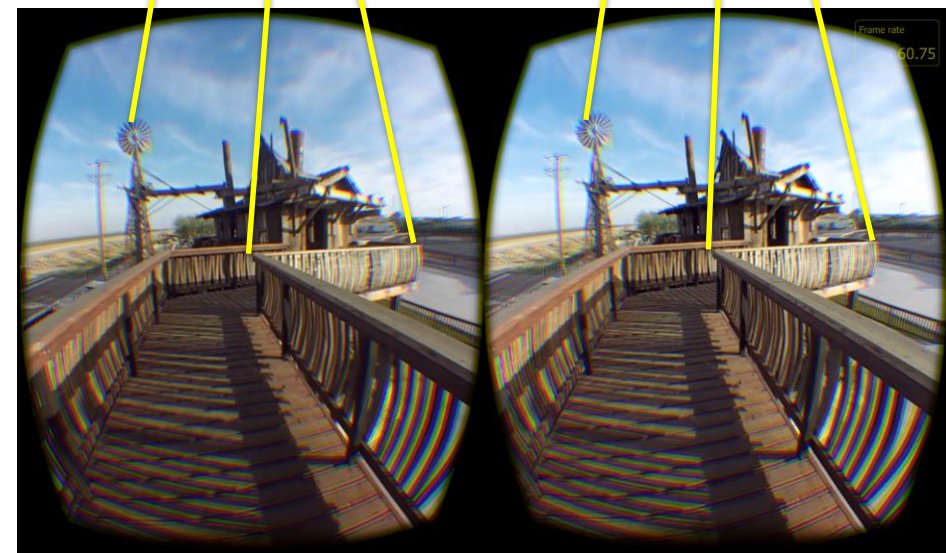

VR headset display

How do we obtain all of the calibration parameters?

CALIBRATION PROCESS

Performing a Calibration

To calibrate, we need to capture a **set of test images**

These test images are used to **compute calibration parameters**

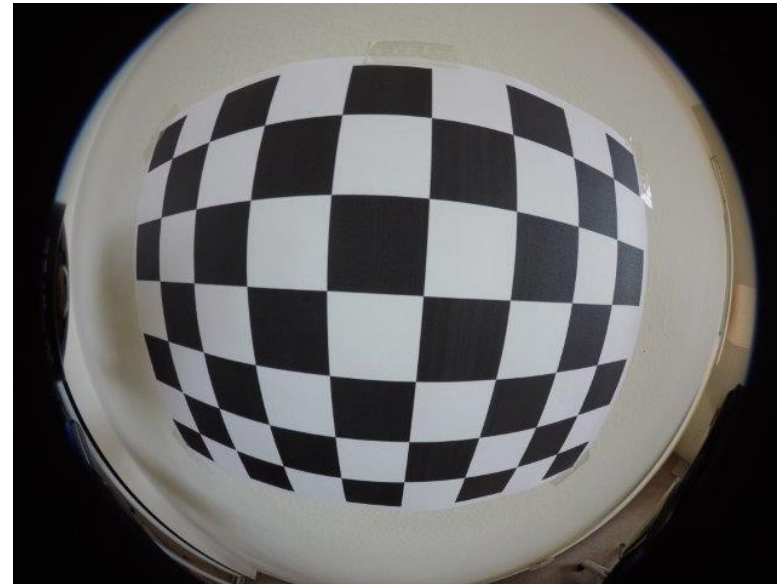
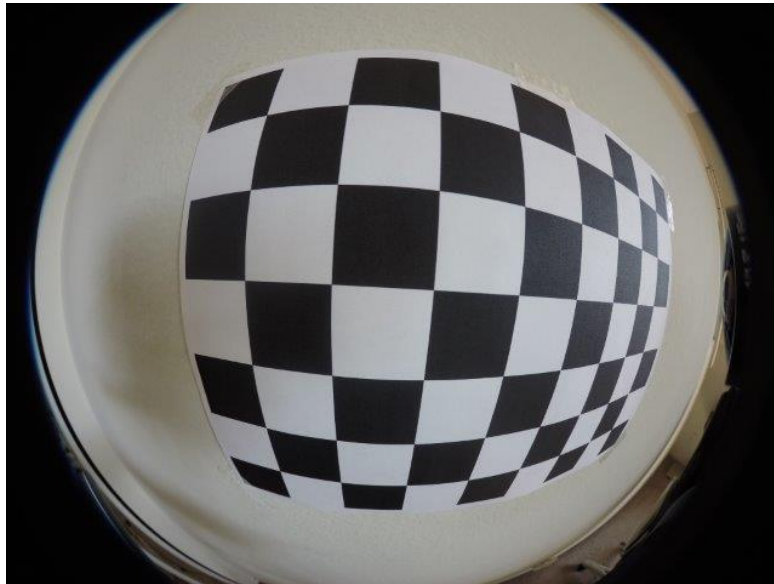

Calibration pattern captured by left and right sensors

Sample Calibration Images

The more images at different distances and orientations the better

Typically a dozen or more orientations are used

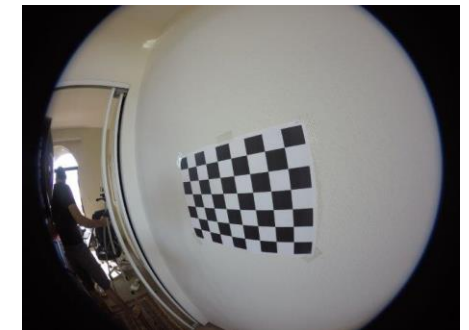
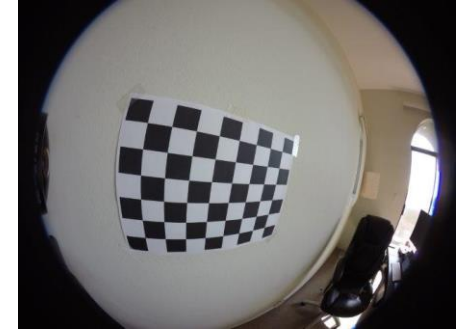
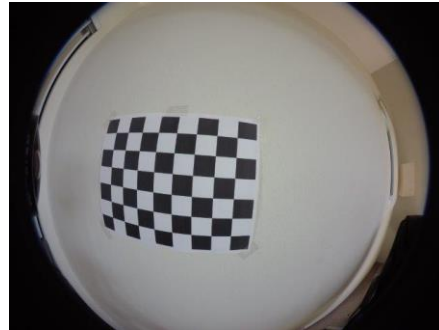
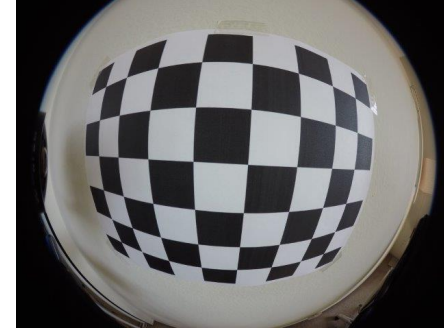
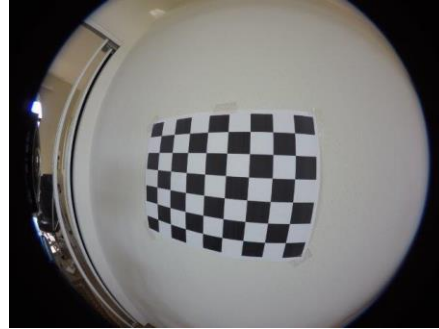

Applying the Calibration

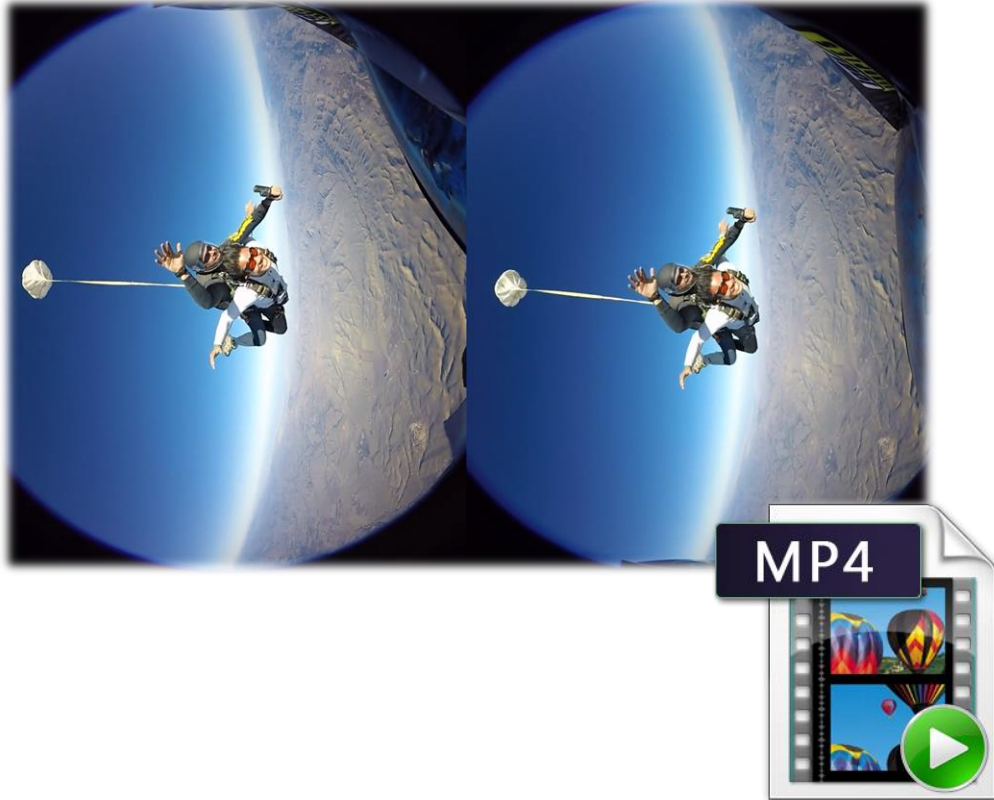

+



Recorded .mp4 video file + Calibration .xml file

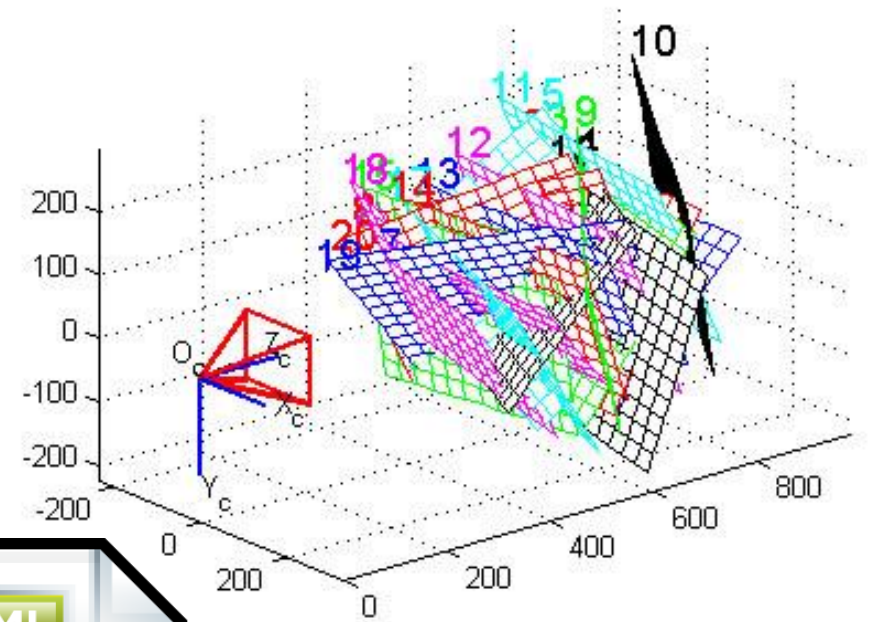

Calibration Program

The calibration image set is passed to our calibration program

The program estimates the optimal stereoscopic calibration settings to explain the distortion in all of the images

- We get back a left and right calibration vector
- Each vector consists of about 10 parameters, to describe the stereoscopic distortion

We use **OpenCV** and other image processing APIs to help perform calibration



360 DEGREE STEREO STITCHING

Video Stitching

Using **3 LucidCams**, we can record 360 degree videos

We need to stitch the **3 left eye** images and the **3 right eye** images

How can we preserve the 3D effect?

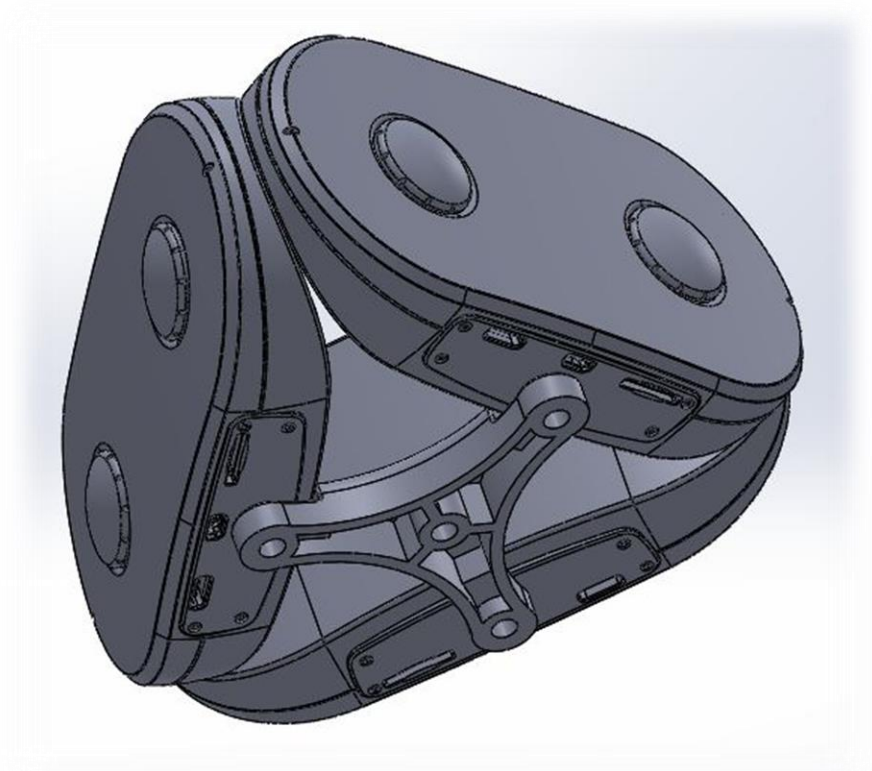

**120 degrees between
each camera**

2D Video Stitching



We have tools and software to do 2D stitching

Getting the stereo effect right is the hard part



Stereo Video Stitching

Stereo video stitching is hard!

3 different camera calibrations

We need to resolve the different lens angle disparities at the seams

There is lots of ongoing research in this field that we're following

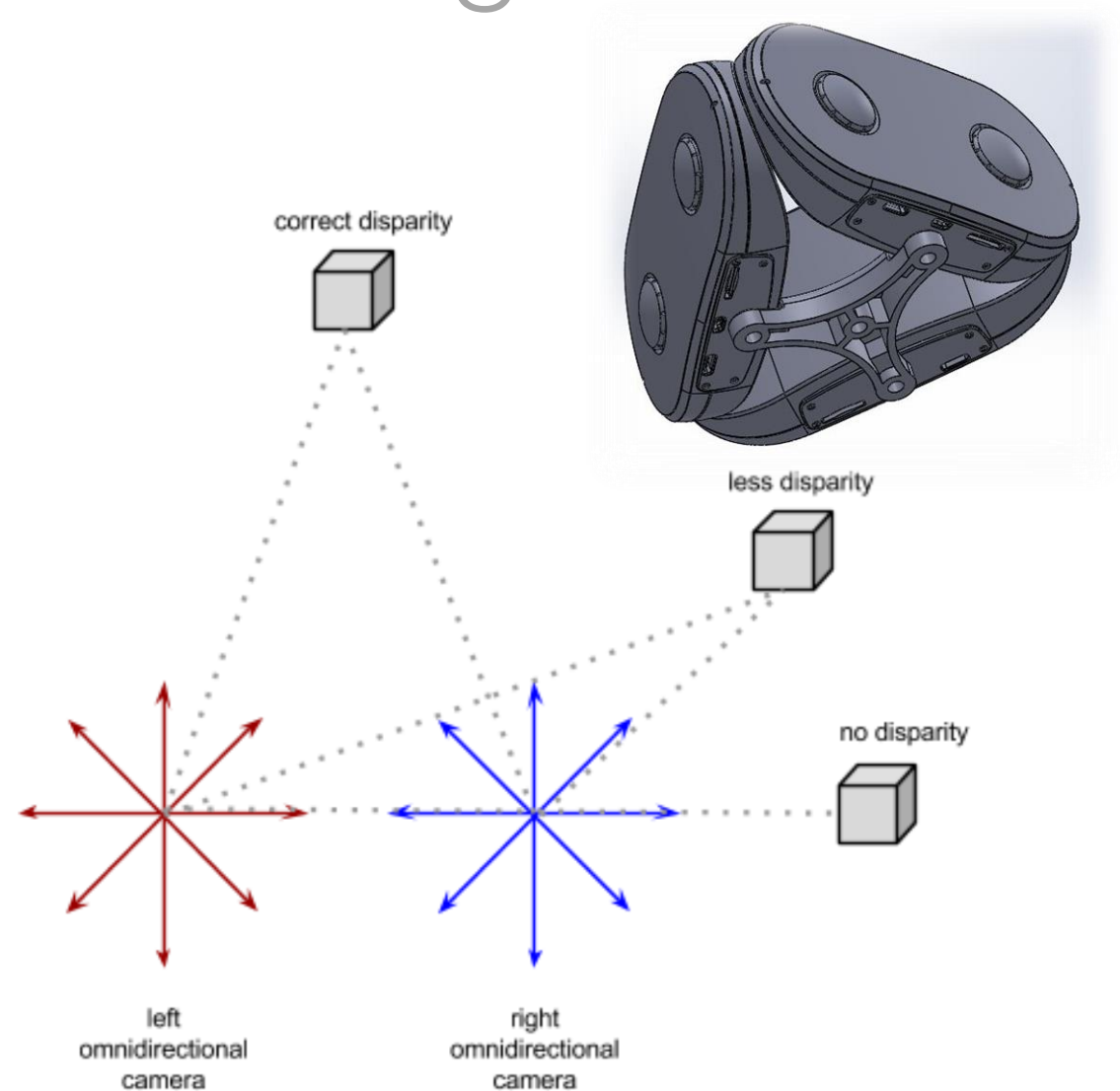

THANK YOU



STEREOSCOPIC 3D CAMERA