

Lesson study on the AREA OF A PARALLELOGRAM for Year 7 students

Leong Yew Hoong

Nanyang University, Singapore
<yewhoong.leong@nie.edu.sg>

**Joseph Phyllis, Lee Hui Ling, Felicia Tan Yi Wei,
Herma Ayuni Binte Hassan, Tay Hui Yih**

Serangoon Garden Secondary, Singapore

The authors of this article came together to form a Lesson Study team with the goal of helping the Year 7 Normal (Academic) students in Serangoon Garden Secondary School develop richer learning experiences in their mathematics classrooms. In Singapore, students in secondary schools are streamed into ability bands. Normal (Academic) is the label for the middle band. The teachers were convinced that Lesson Study provided a valuable platform for professional development. We followed the key steps of the Lesson Study process as delineated by a number of writers (e.g., Stepanek, Appel, Leong, Mangan & Mitchell, 2007; Wang-Iverson & Yoshida, 2005):

1. **Identifying the problem and setting goals.** The first step of the process is for teachers to identify existing problems or difficulties encountered in their instructional practice.
2. **Designing the lesson of focus.** The team meets to design the lesson plan, including lesson objectives, sequences, and materials to be used in class.
3. **Teaching, observing, and refining.** Usually, one member of the team carries out the lesson while the others take on different specific roles during observation of the lesson. A meeting will then be held to reflect on the lesson and to refine aspects of the lesson. The focus of these post-lesson meetings is not on the actions of the teacher carrying out the plan; rather, the purpose of these discussions is primarily to improve the lesson plan;
4. **Sharing of results.** The learning points of the team are shared, consolidated, and then disseminated to a wider audience of professionals in the form of either written reports or by verbal presentations.

As a Lesson Study team, we focused on the topic of Mensuration and subsequently zoomed-in further to the lesson on “area of parallelogram” as

the Lesson of focus. We came together to discuss our experiences in teaching the topic “Area of Parallelogram”, especially the difficulties we faced in helping our students understand how to derive the formula “base \times height”. In the Singapore context, “height” is taken to mean “perpendicular height”. The aim of this paper is to share the learning experiences of the team as we underwent the Lesson Study process.

Area of parallelogram

One of the first considerations that surfaced in our team discussions was that an alternative approach to teaching “area of parallelogram” should address connections between this idea with other concepts (especially those learnt previously) in mathematics. This is so that students do not learn this topic in isolation; rather, it was hoped that when they think of “area of parallelogram”, they would also draw to mind other related knowledge tightly-linked to this concept-in-focus. With stronger conceptual links, we think that students are less likely to forget the method. Moreover, they will have additional mental tools to re-construct the method of computing area of parallelogram should they fail to recall the one-step ‘formula’ of “base \times height”. Making connections is also a valued aspect of the mathematics curriculum in Singapore, as reflected in the insertion of this strand in the latest syllabus revision by the Ministry of Education (MOE, 2007).

The first connection we explored along this line of inquiry is to link area of parallelogram to the area of the corresponding rectangle that shares the same “base” and “height”. Figure 1 shows the typical visual of moving the shaded right-angled triangle piece from one side of the parallelogram to the other to show that the parallelogram can be recomposed into a rectangle. Thus, the area of parallelogram = area of rectangle = base \times height.

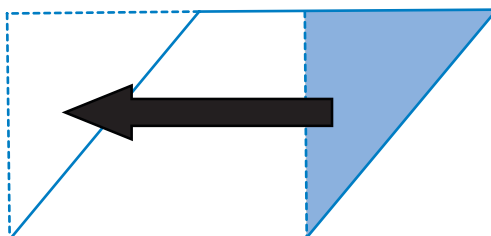

Figure 1. Parallelogram decomposed and recomposed into a rectangle.

Initially, most teachers were positive about this approach as they found the visuals simple enough for the students and easy for the teachers to reproduce. Upon deeper probing, we discussed some further issues that needed to be addressed. First, the approach required two steps:

1. a decomposition of the parallelogram into a trapezium and a right-angled triangle; and
2. a translation of the triangle from one side of the parallelogram to the other to form a rectangle.

Teachers were concerned about step (2). In particular, they wondered if students can perform the visual translation mentally in a way that it becomes a mental tool for them to manipulate parallelograms they confront in future. A few teachers commented that the geometry problems in the Primary levels that required movements of this nature are considered more difficult for students. Second, we noticed that when the parallelogram becomes very skewed, the earlier simple decomposition does not work so easily (see Figure

2); or rather, it requires a decomposition of the parallelogram into more parts, but that would compromise the visual-neatness which is the stand-out feature of this approach. Third, this method of shifting a triangle portion to re-form into a rectangle does not transfer easily when we consider the next figure in the usual instructional sequence: Trapezium. If so, the method can easily degenerate into a one-off procedure that is isolated in its use from the other components of the whole topic on Mensuration. This will not help in our agenda to present mathematics as being connected. Fourth, the language of “base” and “height” are, however, not usually associated with rectangles. This is one challenge of language transition that teachers ought to be sensitised to if using this approach.

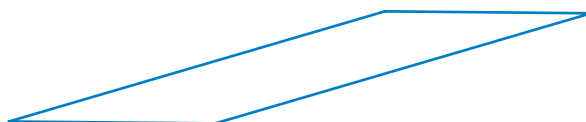

Figure 2. A very skewed parallelogram.

For the above reasons, we explored another approach which is to decompose the parallelogram into two congruent triangles by cutting along a diagonal (see Figure 3). The area of parallelogram is hence equated with twice the area of one triangle = $2 \times (\frac{1}{2} \times \text{base} \times \text{height}) = \text{base} \times \text{height}$. This method avoids the three problems raised in the previous approach:

- no shifting or recomposing into a different shape is needed;
- it works even with very skewed parallelograms; and
- this method can be similarly employed when deriving the ‘formula’ for area of trapezium.

Moreover, no shift of language items—unlike in the case where the conventional language of “length” and “breadth” of rectangle were replaced with “base” and “height”—is required. The terms “base” and “height” are conventionally used for both triangles and parallelograms.

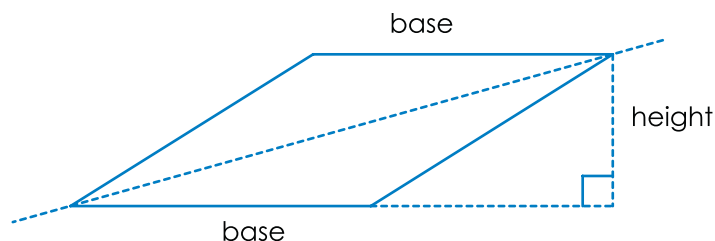

Figure 3. Finding area of parallelogram through decomposition into congruent triangles.

However, this method requires that students are familiar with triangles, and more specifically, with the relationship between base and height of a triangle. We were concerned that if students had weak knowledge of triangles, whatever is built on it—such as area of parallelogram and trapezium—will also be weak. We came to terms with this by reminding ourselves that a substantial revision on triangles is necessary in any case, whether we use this method or otherwise. As such, we see the importance of revising triangles carefully, and putting special emphasis on helping students see the explicit link between area of triangle and area of parallelogram.

Finally, the pragmatic side of us requires that we look into another criterion: Will this method help the students in standard tests/exams? We take the stance that if the method we teach is only for the conceptual

development phase of the topic and not regularly used in standard exercises, they can easily be soon forgotten by the students. Conversely, if students use the method consistently, it can become a conceptual connection that is constantly reinforced and strengthened. We thought that the method of decomposing the parallelogram (or trapezium) into two triangles is straightforward enough and can thus potentially be something students fall back on as a mental tool to help them deal with problems involving area of parallelograms (and trapezium). This need to make connections to triangles would especially be useful in situations when students cannot recall directly the ‘formulas’ for these areas.

The lesson on focus

This was a one-hour lesson. In the first section of the lesson, the teacher for this first cycle (who is also the resident teacher of the class) started with a brief revision on triangles, focusing on labelling “base” and “height” of some triangles she drew on the board. Students then worked on some questions in a worksheet that required the stating of heights of different types of triangles given their respective bases. Examples given in the worksheet covered all types of triangles: acute-angled triangles, right-angled triangles, and obtuse-angled triangles were given. For some triangles, other ‘distractors’ were included to check if students were indeed able to locate the right height that corresponded to the given base. An example of one such item in the worksheet is given in Figure 4. The design of this section of the worksheet was informed by literature on “prototype phenomenon” (e.g., Hershkowitz, 1989; Monaghan, 2000) which highlighted the common misconceptions that students have about “base” and “height”. Anticipated common examples of students’ misconceptions include thinking of base and height as unique to a triangle, base and height being roughly horizontal and vertical respectively, and height being inside a triangle. [To be precise, the term “altitude” should be used in the preceding sentence. The use of “height” here is in keeping with the looser use in the local context where it refers both to the altitude as well as the length of the altitude]. In the worksheet, the choice of examples took into consideration these possible misconceptions. The teacher looked out for these anticipated errors when she observed students’ responses and attempted to address them appropriately. The teacher ended this section of the lesson by summarising that for a given base of a triangle, the height is the (perpendicular) distance between the base and the opposite vertex.

She then moved on to the next section on finding area of triangles. She helped students recall that the area of a triangle is half of the product of a base and its corresponding height.

During our Lesson Study meetings, we discussed whether we should actually help students derive the formula instead of just plain recall here. We finally decided on the latter, for these reasons:

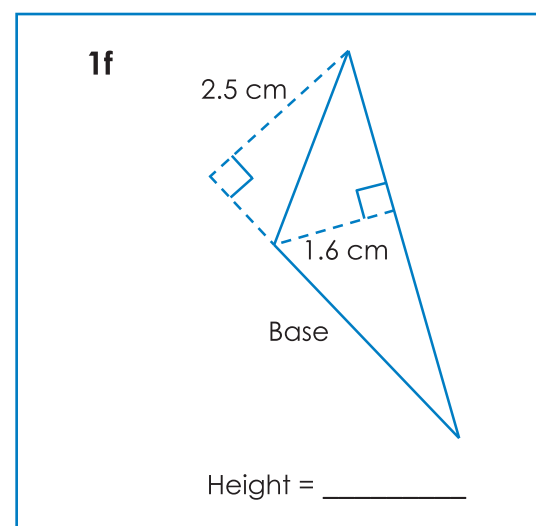

Figure 4. Item 1f of the worksheet.

1. The 'formula' was not new as it was covered in the primary school. We cannot always teach from first principles.
2. The focus of the lesson was to use the area of triangles to find the area of a parallelogram.

We were apprehensive about diverting students' attention to another activity on the derivation of area of triangle.

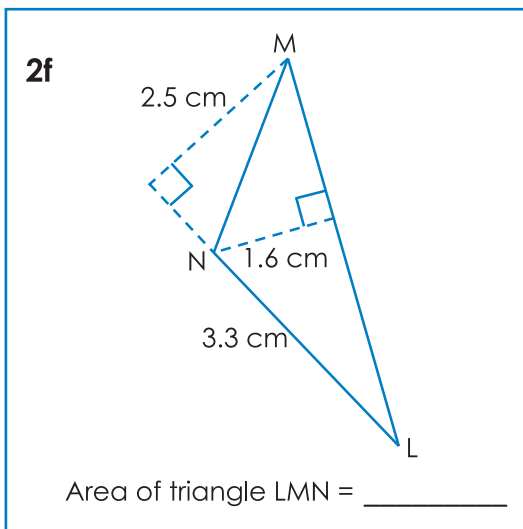

Figure 5. Item 2f in the worksheet.

After showing an example in which she demonstrated the computation of area using the $\frac{1}{2} \times \text{base} \times \text{height}$ 'formula', the students proceeded to attempt the second section of the worksheet where they computed areas of different types of triangles. One such example in the worksheet is given in Figure 5. Like in the first section of the worksheet, the examples used in this second section covered a range of different examples that, when taken together, reinforced the critical attribute of height as paired with the base and is the perpendicular distance between the base and the opposite vertex.

The last section of the lesson was meant as a bridge to connect the previously revised area of triangle knowledge to derive the area of parallelogram 'formula'. The teacher did

so by engaging the students in a cutting activity. Students were given three parallelograms cutouts of different sizes and skewness. These parallelograms were duplicated on the students' worksheets. In pairs, the students were to cut each parallelogram so that it can be decomposed into two congruent triangles. These congruent triangles were then pasted onto the respective parallelograms in their worksheets. After the activity, the teacher summarised by calling to attention that each parallelogram can be decomposed into two congruent triangles when cut along a diagonal. She then wrote on the board that

$$\text{area of parallelogram} = \text{area of two triangles} = 2 \times \left(\frac{1}{2} \times \text{base} \times \text{height} \right) = \text{base} \times \text{height}$$

After that, she only had time to apply the "base \times height" formula on one exercise question before the lesson ended.

Student Jane

Each Lesson Study team member was assigned to sit beside students during the Research lesson to observe their learning behaviour. The first author of this article (henceforth referred to simply as "I") was observing student Jane (a pseudonym) throughout the research lesson. Jane's responses on her worksheet revealed her interpretation of the lesson and can hold important lessons for a revision of the lesson for Cycle 2.

For the first section of the worksheet, Jane was able to proceed quite smoothly—giving correct answers and almost immediately, until Item 1f (see Figure 4). I noticed a discernible pause to look more closely at the diagram. She did eventually give the correct input. For the subsequent questions, there were also pauses but not as long as that for 1f. I interpreted that Jane had found something significantly different in 1f from the previous items. I

was curious to investigate what they were. I observed that the main difference between 1f and the previous items (for example, see 1e shown in Figure 6) was that there were two perforated segments with the perpendicular \perp symbol, whereas there was only one such segment in the previous items. Perhaps Jane was struggling with the two perpendiculars, deciding which to choose as the answer. If that was the case, it would also mean that she had yet to, at that point, develop a strong concept of height being related to the given base. It would also mean that she was aware that “perpendicular” is a critical attribute of height (since this strategy of looking for perpendiculars as “height” would work for the previous items, such as 1e), but not yet conscious of the critical attribute of height as “perpendicular to the base”. It could be the juncture where Jane started to consider other possible attributes of “height”.

That Jane seemed to be narrowly focusing on the \perp symbol gained evidence from her work in Section 2 of the worksheet. In all the items, she consistently computed the area of triangle in the order of $\frac{1}{2} \times \text{height} \times \text{base}$ instead of $\frac{1}{2} \times \text{base} \times \text{height}$, even though the latter is more conventional and certainly the one highlighted by the teacher. I interpreted this to mean that she was first looking out for height (by searching for the segment with the \perp symbol) and then figure out the base. For example, in 2f (see Figure 5), she first wrote “h” beside “2.5 cm”, then “b” along side ML. She then looked uncertain, checked the work of her partner, before striking out the “b” and putting it beside “3.3 cm” instead. Unfortunately, 2f was the only item in Section 2 that showed two perpendiculars. The rest of the items presented only one perpendicular and thus she was not challenged again to re-examine her understanding of the base-height relationship in triangles.

In Section 3 of the lesson, Jane was meticulous in the cutting and proceeded smoothly to paste the triangles correctly into the three parallelograms provided in the worksheet. I observed too that for the first parallelogram, she held the two decomposed triangles and fitted them together to check that they fitted exactly. It seemed that she was confirming her hunch that the two triangles when decomposed along the diagonal were indeed congruent. This discovery seemed important to her. In the last part of the lesson when the teacher used $\text{base} \times \text{height}$ to compute the area of the parallelogram, she did something noticeably different from what the teacher wrote on board: She wrote $2 \times (\frac{1}{2} \times \text{base} \times \text{height})$ instead on her own accord and went on to compute the area. It perhaps indicated that she saw the parallelogram through the lens of two triangles and that the triangles were congruent. If so, this approach of hers fitted into the progression that was intended in our design of the lesson—that students build on area of triangle in deriving the area of parallelogram and that they can henceforth use this decomposition as a mental tool for dealing with similar questions in future.

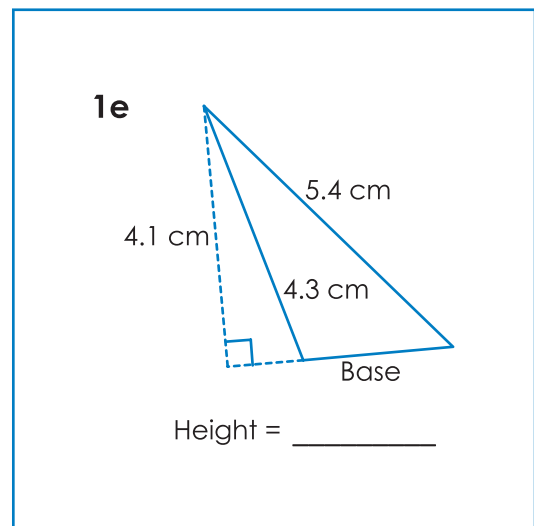

Figure 6. Item 1e of the worksheet.

Lessons for Cycle 2

During the post-lesson meeting, we learnt that Jane's difficulty with pairing the correct height with the given base of a triangle was not unique to her. Other teachers observed that other students had similar difficulties. These difficulties confirmed in us the misconceptions students can have about base-height relationships in triangles that we anticipated through experience and from the literature. In that sense, we were glad that a substantial amount of time was spent in the lesson to help students revise these concepts. It also substantiated our earlier hunch that if we were to approach the area of parallelogram by decomposition into triangles, students needed to be clearer in these subordinate knowledge and skills of computing area of triangles.

However, there were specific misconceptions that we had not anticipated. We acknowledged that while the worksheet provided many examples to highlight that "perpendicular" is a critical attribute of "height", there was not enough examples to emphasise the "perpendicular to the base" feature. We agreed that for Cycle 2, the worksheet can be amended to include more examples with two or more \perp symbols to challenge students' concept of "height". There should be more explicit teaching about the base-height pair relationship, including examples for students to draw their choices of base and height for given triangles.

We took some encouragement that students such as Jane were linking area of parallelogram to the earlier development of decomposition into triangles. It was still early then to know if such connections would persist and become usable as a mental tool to aid in their tackling of similar problems in future. Nevertheless, these evidences were in line with the broad intent of helping students make connections in their learning.

Overall reflection by team members

For everyone on board the Lesson Study team, it had definitely been a rich learning experience for all of us. Through planning the lessons collaboratively, we were able to deepen our subject matter knowledge as well as instructional knowledge. It provided us with the precious opportunity to actually develop "eyes" to see how our students process their thinking, how misconceptions and difficulties by the students can arise and how it has been an eye-opener to see how the students interpret the teaching differently although they were taught by the same teacher. We were able to reflect about the lesson and the rich learning by the teachers did not end when we step out of the classroom. We learnt that a good lesson is one that meets the learning needs of the students.

An issue the team had to grapple with was whether it was worth spending an unusually large amount of time to help students acquire the mental tools to re-construct the method of computing the area of parallelogram through the cutting activity and the scaffolding provided. At the back of our mind, there was always this problem of time constraint. In the end, we concluded that it was indeed worth the time spent as we provided our students with the opportunity to be flexible in their thinking (as they had to deconstruct and reconstruct parallelograms and trapeziums) and we also enriched their learning experiences. We now look forward to the next Lesson Study project.

References

- Hershkowitz, R. (1989). Visualisation in geometry: Two sides of the coin. *Focus on Learning Problems in Mathematics*, 11(1), 61–76.
- Monaghan, F., (2000). What difference does it make? Children's views of the differences between some quadrilaterals. *Educational Studies in Mathematics*, 42(2), 179–196.
- Ministry of Education. (2007). *Secondary Mathematics syllabus*. Singapore: Author.
- Stepanek, J., Appel, G., Leong, M., Mangan, M. T. & Mitchell, M. (2007). *Leading lesson study: A practical guide for teachers and facilitators*. CA: Corwin Press.
- Wang-Iverson, P. & Yoshida, M. (2005). *Building our understanding of lesson study*. PA: Research for Better Schools.

The Numerical Acumen Challenge

May 1st, 2012 to November 1st, 2012

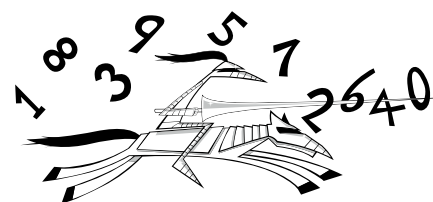

PRINCE ALFRED COLLEGE

The Potts-Baker Institute, Prince Alfred College presents a challenge to Australian school students of all year levels: **The Numerical Acumen Challenge.**

What is the challenge?

To master a series of mental calculation strategies (something that is frequently mentioned in the K-10 Australian Curriculum).

The strategies are organised into four units, and each unit has a game that can be played at one or more Difficulty Levels.

The units for 2012 are:

- Doubling
- Near Doubles
- Adding Near 10s
- Hop To 10

The Difficulty Levels are:

1. Starting Out
2. Moving On
3. No Pain No Gain
4. I Have No Fear

How do students master the strategies?

- Learn the basics of a strategy (support booklets provided)
- Start playing the games at a suitable Difficulty Level



Each game has a number of stages, with each stage having a goal to reach. Three lives are granted and a time limit is set.

- Keep playing, and work towards mastering a Difficulty Level

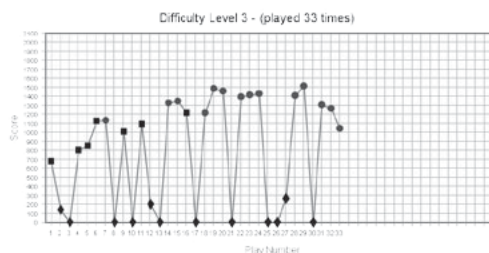

Progress is logged and displayed in simple to understand graphs.

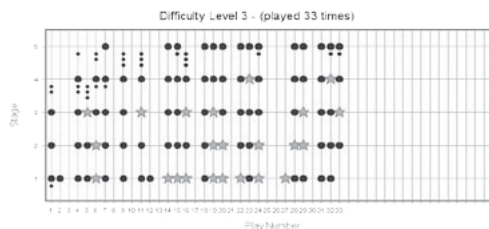

How do students meet the challenge?

Achieve a Gold Star in each stage of a given Difficulty Level for each unit to earn an award.

- Bronze award for the *Starting Out* Difficulty Level
- Silver award for the *Moving On* Difficulty Level
- Gold award for the *No Pain No Gain* Difficulty Level
- Platinum award for the *I Have No Fear* Difficulty Level

For more details visit www.numericalacumen.com