

## A SCALE DEVELOPMENT TO DETERMINE UNIVERSITY STUDENTS' ATTITUDES TO ONLINE EXAMS ASSESSMENT

**Korhan ARUN,<sup>1</sup>**

Associate Professor  
Namık Kemal University

karun@nku.edu.tr

ORCID: 0000-0001-7494-9591

**Nesli KAHRAMAN GEDİK,<sup>2</sup>**

Lecturer  
İstanbul Aydın University

neslikahramangedik@aydin.edu.tr

ORCID: 0000-0001-6531-8018

**Zeynep Feride OLCAY,<sup>3</sup>**

Doctor Lecturer  
İstanbul Aydın University

zeynepolcay@aydin.edu.tr

ORCID: 0000-0001-5720-7350

**Güven ÖZDEMİR,<sup>4</sup>**

Doctor Lecturer  
İstanbul Aydın University

guvenozdemir@aydin.edu.tr

ORCID: 0000-0001-9616-8470

**Mustafa ÇIKRIKÇI,<sup>5</sup>**

Professor Doctor  
İstanbul Aydın University

mustafacikrikci@aydin.edu.tr

ORCID: 0000-0002-2805-6079

### **Abstract:**

**Purpose:** This study aims to develop and validate a scale to determine university students' attitudes toward assessment and evaluation in online exams. **Background:** Measuring students' attitudes toward online exams is crucial, especially in the context of emergency transitions to online learning and the impact of external factors such as the COVID-19 pandemic. Students' perspectives on online examination practices in higher education institutions are significant in understanding students' attitudes and perceptions of online exams for effective implementation. **Method:** During the developmental phase of the

---

<sup>1</sup> Corresponding author, responsible for methodology, writing-review, and editing, and supervision.

<sup>2</sup> Co-author, responsible for formal analysis, investigation, and software.

<sup>3</sup> Co-author, responsible for conceptualization, writing-original draft, resources, and data curation.

<sup>4</sup> Co-author, responsible for data curation, and visualization.

<sup>5</sup> Co-author, responsible for writing-original draft.

Arun, K. et al. (2023). A scale development to determine university students' attitudes to online exams assessment. *Advanced Education*, 23, 157-169. DOI: 10.20535/2410-8286.283028

*scale, 13 items were created and presented for expert opinion. The scale propositions are designed to question the compliance of the courses with the curricula in the online education process, the transparency of online exams, and the University's technological infrastructure for online exams. The participants in the study consist of 1095 students studying in different programs at the Vocational Schools of three foundation universities in Istanbul, and they were reached via e-mail. Explanatory Factor Analysis (EFA) and Confirmatory Factor Analysis (CFA) were conducted. **Findings:** The results obtained prove that the 13-question scale is valid and reliable and is a good measurement to determine university students' attitudes to online exams. **Implications for Research and Practice:** Attitudes are likely determinants of academic achievement. Furthermore, utilizing e-tests positively impacts higher education students' performance and participation in online testing. Therefore, it is essential to consider students' attitudes towards online exams to increase academic success in online courses and provide better learning outcomes. Thus, scale development plays a pivotal role in advancing knowledge within specific domains of social science research, and it is integral to ensuring the quality and reliability of online exam instruments used in higher education.*

**Keywords:** Distance education and online learning, Mobile Learning, Evaluation methodologies.

## 1. INTRODUCTION

World Health Organization (WHO) classified Covid-19 as a global pandemic (WHO, 2020) that has also affected Turkey as of March 11, 2020 (Ministry of Health, 2020). To reduce the spread and impact of the pandemic, one of the decisions is to interrupt face-to-face education in schools and switch to distance education (Bozkurt et al., 2020). However, as in the world, the transition to distance education has been made with a decision taken very quickly in higher education in our country. The possibility of continuing education activities based on information and communication technologies without risking life safety against coronavirus was effective in this decision (Emin, 2020). These reasons have enabled the distance education approach to become an easy and applicable solution (Yamamoto, 2020). Furthermore, while online education has positive aspects, studying the practical challenges and student perceptions of online exams in the context of distance education are crucial for the effective design, implementation, and evaluation of online exams in higher education (Kartallioğlu, 2022).

In the Spring semester of the 2020-2021 academic year, institutions, teachers, and students faced an education and training model they had never encountered before. Institutions, while taking steps to inform students and parents, give them confidence, and maintain communication, have also had to increase their ability to teach remotely. For instance, a survey by Means and Neisler (2020) found that during the pandemic, student interest and satisfaction have drastically declined, with half of the American students expressing unhappiness with their learning after their course went online. In addition to the difficulties of transferring information about the curriculum to the students in the online environment, some difficulties were experienced in testing and evaluation, which is an integral part of the education system. The closure of educational institutions during the

pandemic has also affected the examination systems, and the testing and evaluation process has begun to be implemented via the Internet.

Testing and Evaluation activities are used to evaluate the teaching process in the distance education system and to determine whether the target achievements have been obtained (Kavas, 2009). Online testing and evaluation can be applied through online exams by taking advantage of the opportunities offered by technology (Donovan, Mader, & Shinsky, 2007). Furthermore, information and communication technologies can facilitate the testing and evaluation of skills, knowledge, abilities, or competencies (Gülbahar, 2013).

Online exams have numerous benefits. Firstly, online exams are more efficient regarding time, effort, and money spent on the exam process (Shraim, 2019). They also offer a flexible option for authentic assessment and are viewed favorably by students (Linden & Gonzalez, 2021). Additionally, online exams provide immediate scoring, allowing students to receive rapid feedback regarding their performance, which is beneficial to learning (Brallier et al., 2015). Online exams are also practical for diagnostic, formative, and summative assessments, allowing students to demonstrate their performance (Afacan Adanır et al., 2020).

Furthermore, online exams can reduce test anxiety experienced during the exam and improve exam scores (Stowell & Bennett, 2010). However, it is important to prevent cheating in online exams, which can be achieved through online proctoring systems (Jia & He, 2022). Overall, online exams offer numerous benefits and are an excellent method of conducting important exams with the help of the Internet (Ali & Iftikhar, 2021).

On the other hand, online or e-testing in higher education has several disadvantages. One of the main challenges is the need for more student discipline to prevent cheating and academic dishonesty (Hermanto & Srimulyani, 2021). Not all students have access to reliable Internet and technology, which can create inequalities in the testing process (Karunarathne & Wijewardene, 2021). Lack of social interaction is another disadvantage of online testing, as it can lead to a lack of engagement and motivation among students (Hermanto & Srimulyani, 2021). Online testing can also be problematic for specific fields, such as physical education, where hands-on experience is necessary (Titarenko et al., 2020).

Furthermore, online testing may not accurately assess specific skills, such as critical thinking and problem-solving, which require more complex evaluation methods (Boitshwarelo et al., 2017). Finally, concerns about the validity and reliability of online testing are increasing as online learning environments become more prevalent in higher education (Reeves, 2000). Consequently, measuring the attitudes of higher education students will help to ease or overcome these opposing sides while improving the advantages of online or e-exams.

Several studies have investigated university students' attitudes toward assessment and evaluation in online exams. Shraim (2019) conducted an online questionnaire survey of 342 undergraduate students and found that students perceived online exams to have advantages in terms of pedagogy, validity, reliability, affective factors, practicality, and security. Similarly, a recent study examined the attitudes of 661 associate degree students toward online exams. It concluded that the students' attitudes were above the midpoint, and the attitude scores differed according to gender, internet use time, and skills (Sirakaya et al., 2015). However, Gamage et al. (2022) found that students are anxious about their

Arun, K. et al. (2023). A scale development to determine university students' attitudes to online exams assessment. *Advanced Education*, 23, 157-169. DOI: 10.20535/2410-8286.283028

grades and the technical hassle they experience in online exams. Ünal and Altuğ (2021) evaluated the level of satisfaction with the online method of teaching applied courses and the online method of conducting exams. They found that students were generally satisfied with both methods. Yılmaz and Toker (2022) analyzed the effects of assessment and evaluation applications and exam formats in distance education. They found that online assessment evaluation activities and exam types significantly affected student achievement scores. However, Kholid (2021) found that perceived behavioral control, subjective norm, attitude, and perceived benefits positively affect the intention to cheat on online exams. While there are mixed attitudes towards online exams, students view them favorably due to their flexibility and convenience.

Attitudes in individual psychology refer to an individual's evaluation or judgment of an object, person, or situation, which can influence their behavior (Halvaşı, 2019). Attitudes can be positive or negative and vary in intensity and stability (Tarantini et al., 2019). Overall, attitudes play an important role in shaping an individual's behavior and can have significant implications for various aspects of life.

Attitudes can have various effects on individuals and their behavior. Attitudes can influence cognitive processes, such as perception and memory, and affect decision-making and behavioral intentions (Luttrell & Sawicki, 2020). Attitudes can also affect higher education, including academic engagement, success, and inclusion of students (Abun et al., 2019). Studies have shown that students' cognitive and affective attitudes toward higher education correlate significantly with academic engagement (Abun et al., 2019). Additionally, attitudes can impact academic achievement, as academic attitudes of male and female students and teachers have been found to impact students' academic achievement (Daviran, 2015). Finally, attitudes, practices, and policies can shape how K-12 and higher education students are perceived and treated as risks, affecting their access and success in postsecondary education (Huerta & Britton, 2022).

The impact of e-tests on students' performance and attitude toward online testing versus the traditional approach (pen and paper tests) has also been investigated (AlAdl, 2020). The study found that e-tests positively impacted students' performance and attitude toward online testing. Therefore, it is essential to consider students' attitudes toward e-learning to increase academic success in online courses and provide better learning outcomes (Dikmen, 2020). Motivation and a positive attitude among students are crucial factors for the successful adoption of e-learning by universities. (Shakah et al., 2019). As a result, students' attitudes toward online exams should be considered. Moreover, in the social sciences, scale development enables researchers to measure intangible concepts such as attitudes, and behaviors, which are central to understanding human interactions and societal phenomena (Cakiroglu & Baykal, 2021). Therefore, this study aims to develop a scale to determine university students' attitudes toward online exams.

## **2. METHOD**

The steps followed for the scale development study are:

Creating the item pool (literature review), Submitting the item pool to expert opinion to examine the content validity, Presenting the draft scale to the language experts and applying it to the study group, Performing Exploratory Factor Analysis (EFA) and Confirmatory Factor Analysis (CFA) to evaluate the construct validity of the scale, making

item analysis, Calculating the Cronbach Alpha internal consistency coefficient regarding the reliability of the scale.

### **Creating Item Pool**

To establish a scale for evaluating measurement and assessment activities related to exams, initially, 50 students randomly selected from a foundation university in Istanbul were asked an open-ended question about the advantages and disadvantages of online exams. Questions were prepared based on the feedback received from these 50 students and a literature review, utilizing the scale items developed by Karakuş (2022) and Şenel and Şenel (2021).

### **Expert Opinion on Content Validity**

To determine the suitability of the written items for the intended structure, clarity of expressions, comprehensibility, and whether they adequately represent the relevant scope, expert opinions were obtained from four academicians, including two experts in the field of Measurement and Evaluation and two experts in Turkish Education. After the specified adjustments, the scale items took their final form."

The assessment tool, which was prepared to collect data within the scope of the study, was sent to the Vocational School students of three foundation universities in Istanbul via e-mail. A total of 1095 of 1500 vocational school students, who were students in different vocational school programs, answered the questionnaires. They were reached via e-mail. At the first stage of the scale development, the literature was examined and attempted to determine the students' attitudes toward online exams. In this context, 13-item questions were formed. Participants were expected to express their perceptions about their online exams on a 5-point Likert-type scale ranging from "Strongly agree", "Agree", "I am undecided", "Disagree" and "Strongly disagree". The questionnaire form created to collect the data was sent to the department's faculty members, who are the program heads, with an explanatory e-mail containing information about the research, and the students in the programs were asked to participate in the study. Questions were answered by 1095 students voluntarily.

## **3. ANALYSIS OF DATA AND RESULTS**

To analyze the obtained data, the validity and reliability studies of the scale were carried out in line with the answers from 1095 students who agreed to participate in the research. The sample size required for factor analysis was examined within the scope of the study, and the study group was deemed sufficient (Tabachnick & Fidell, 2001). Explanatory Factor Analysis (EFA) was conducted to determine the scale's construct validity, which was prepared to determine university students' attitudes toward Testing-Evaluation in Online Exams. In the analysis, factor loads were determined as at least .60. Cronbach Alpha coefficient was calculated for the total reliability of the scale. In addition, Confirmatory Factor Analysis (CFA) was conducted to test the accuracy of the structure revealed by EFA. Before starting the factor analysis, the Kaiser-Meyer-Olkin (KMO) coefficient and Bartlett Sphericity test were calculated to determine the suitability of the data. The KMO value was found to be .95, and the Bartlett test result ( $p = 0.000$ ) was also significant (George & Mallery, 2001). As a result of EFA, it was seen that the scale was gathered under a single factor with an eigenvalue greater than 1. The variance explained

Arun, K. et al. (2023). A scale development to determine university students' attitudes to online exams assessment. *Advanced Education*, 23, 157-169. DOI: 10.20535/2410-8286.283028

by this single factor regarding the scale is 52.725%. Table 1 presents the characteristics of 13 items on the scale.

**Table 1.** Factor structure of the scale items

Matter	EFA
1- Before the online exam, an explanation was made by the instructors from the University's online system regarding the distribution of questions and scoring in the exam.	,632
2- The time allotted for online exams was sufficient.	,713
3- The questions in the online exams were compatible with the topics covered in the course.	,802
4- Online exams were held on reasonable (appropriate) days and times.	,669
5- Online exams started and ended in the order and calmness that should be.	,790
6- In online exams, it is stated which question has how many points.	,674
7- Since I know the scores of the online exam questions, the exam results do not surprise me. I get the grade I have been waiting for.	,729
8-I believe that the end-of-year grades given to my courses are fair.	,754
9- During the online exam process, the instructors in my department provide all kinds of support.	,807
10- The system was fine during the online exams.	,722
11- Computer support was sufficient during the online exam process.	,684
12- Online exams have been implemented in a way that does not allow cheating.	,661
13- Online exam questions were flawless.	,774

As seen in Table 1, the factor load of the scale consists of 13 items ranging from .661 to .802. It was seen that all items explained 52.9725% of the total variance.

As a result of the Confirmatory Factor Analysis (Figure 1), it was seen that the structure revealed in the EFA was confirmed. This result also shows that the dimensions created by considering the literature are statistically verified.

### Confirmatory Factor Analysis with Structural Equation Modeling

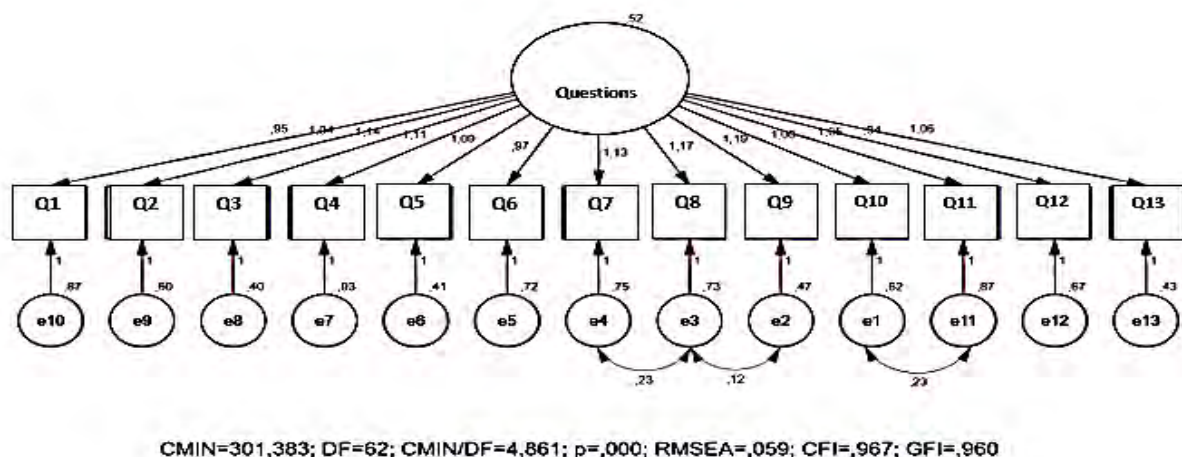

**Figure 1:** Structural Equation of Confirmatory Factor Analysis Model

The scale was created to determine Vocational School students' attitudes towards Testing-Evaluation in Online Exams. A single-factor structure was examined for 13 items in the structure examined. As a result of confirmatory factor analysis, model fit criteria were examined. After the index analysis, it was determined that there was a covariance connection between item 7 and item 8, item 8 and item 9, and item 10 and item 11. The

result analysis revealed CMIN=301,383, DF=62, p=.000, CMIN/DF=4.861, RMSEA=.059, CFI=.967, GFI=.960, respectively. It is seen that the model fit criteria obtained are within the accepted limits.

**Table 2:** Path Coefficients of Items in the Scale

	$\beta_0$	$\beta_1$	S.E.	C.R.	P
Item 10	0,677	1			
Item 9	0,781	1,191	0,051	23,276	,000
Item 8	0,704	1,17	0,055	21,176	,000
Item 7	0,684	1,127	0,054	20,673	,000
Item 6	0,638	0,974	0,05	19,426	,000
Item 5	0,775	1,086	0,047	23,142	,000
Item 4	0,639	1,108	0,057	19,467	,000
Item 3	0,793	1,144	0,048	23,6	,000
Item 2	0,694	1,036	0,049	20,979	,000
Item 1	0,595	0,955	0,052	18,215	,000
Item 11	0,63	1,048	0,045	23,193	,000
Item 12	0,637	0,935	0,048	19,388	,000
Item 13	0,758	1,06	0,047	22,702	,000

$\beta_0$ : Standard Path Factors  $\beta_1$  : Non-Standard Path Coefficients

All items' Path coefficients were statistically significant in confirmatory factor analysis. When the standardized road coefficients are examined, it is seen that the item that has the most effect on Assessment - Evaluation is item 3 ( $\beta_0 = 0.793$ ). The second and third effective items in order are item 9 ( $\beta_0 = 0.781$ ) and item 5 ( $\beta_0 = 0.775$ ). The most ineffective item is item 1 ( $\beta_0 = 0.595$ ).

The standardized regression coefficients in a structural model are represented by path coefficients in AMOS, a structural equation modeling (SEM) program. The intensity and direction of the correlations between the latent variables and the observable variables in the model are indicated by these coefficients. Understanding the route coefficients during scale development can help validate and improve the scale by illuminating the connections between various components and their indicators (Byrne, 2010). Path Coefficients of Items in the Scale from Table 2 show that standard path factors higher than 0.5 state satisfactory relations (Brown, 2015).

### Findings Regarding Reliability

The Cronbach Alpha internal consistency coefficient was calculated for the reliability of 13 items of the scale. The internal consistency coefficient was determined as .92. The obtained values show that this scale is a reliable evaluation tool to measure students' attitudes towards assessment and evaluation in online exams.

Even while Cronbach Alpha is frequently employed as a reliability indicator, its relationship to the definition of reliability may need to be clarified with other reliability indicators. Furthermore, rather than being the best estimate of the actual reliability, it is typically a lower bound on the actual reliability of a group of objects. Sijsma (2009) contends that viewing alpha as indicative of this is oversimplifying and that internal

Arun, K. et al. (2023). A scale development to determine university students' attitudes to online exams assessment. *Advanced Education*, 23, 157-169. DOI: 10.20535/2410-8286.283028

consistency is about the factor structure of a set of items. As a measure of reliability, coefficient alpha is not the only option. Split-half reliability is a possible substitute. There are numerous theoretical approaches to reaching split-half reliability. The item subsets can be created in various ways, including balanced and random halves. In the first scenario, one might point out certain crucial item qualities. The scale would then be divided in half such that each side had an equal representation of the attributes. Thus, an investigator may divide the items into subsets with an equal number of items written in the first person, short items, etc., in each subset. It would be helpful if there were more lengthy first-person items than shorter ones that we liked using this method (DeVellis & Thorpe, 2022). Under these conditions, the correlation between one form and the other is equivalent to correlating either form with itself, as each alternate form is equivalent to the other. The correlation between the two tests equals the reliability of each. In our sample, the correlation between the forms is 0.835, and Spearman-Brown coefficients (equal and unequal, should be more than 0.80) are 0.910, indicating high reliability.

The standardized regression coefficients in a structural model are represented by path coefficients in AMOS, a structural equation modeling (SEM) program. The intensity and direction of the correlations between the latent variables and the observable variables in the model are indicated by these coefficients. Understanding the route coefficients during scale development can help validate and improve the scale by illuminating the connections between various components and their indicators (Byrne, 2010)

#### **4. DISCUSSION**

In this study, to determine the attitudes of Vocational School students towards testing and evaluation in online exams, a 13-item scale was developed. After the analysis of the result, it was seen that the scale had sufficient features. The factor loads and standard path coefficients of the 13 items in the scale are above 0.60, and the fit indices are within the desired limits. According to the KMO coefficient (KMO=.95;  $p=.00$ ), the sample adequacy is excellent, in line with the classifications in the literature. Since the Cronbach Alpha reliability coefficient ( $\alpha=.92$ ) was greater than 70, it was seen that the reliability coefficient was sufficient, and the scores obtained from 13 items in the scale were reliable.

Path coefficient results from Table 2 show that item 3, "3- The questions in the online exams were compatible with the topics covered in the course", has the most impact on the scale. As a result, online or not lecturers should carefully construct the exams that must include the topics. Item 9, "During the online exam process, the instructors in my department provide all kinds of support", has the second most effect on Assessment – Evaluation. So, university management should carefully consider support from instructors and lecturers. These results support the view that the role of source credibility in attitude change has been significant in influencing attitude change (Rhine & Severance, 1970;). The effects of persuasive technology on attitude change have been demonstrated to show that intentional design can influence a person's attitude or behavior. However, the covariance from item 1 supports the opposite. The item "An explanation was made about question distribution and scoring in the exam by the instructors on the university's online system before the online exam" has the least impact on the scale. Thus, explanations of online exams should be limited to the most important or easily forgotten aspects of the



online exams. More clearly, stating the explanations before exams by technology cannot be persuasive for, at least, university students.

The least effective item on the scale is item 1, "1- Before the online exam, an explanation was made by the instructors from the University's online system regarding the distribution of questions and scoring in the exam.", that students don't want to be instructed for standard procedures and operations ( $\beta_0 = 0.595$ ). As a result, it can be said that standard reminding of the exam procedures are regarded as boring and must be shortened or omitted completely.

Studies have found that students generally have positive attitudes toward online exams, while others have highlighted challenges and concerns (Stradiotová et al., 2022). For example, Alruwais et al. (2018) reported that most students preferred online evaluations over traditional ones. Thus, attitudes are important for many factors for online evaluation. First, attitudes of students regarding student cheating behaviors in online exams are correlated (Khold et al., 2021; Reedy et al., 2021). So, negative attitudes affect the intention to cheat on online exams. Second, attitudes positively affect students' satisfaction with the University (Basuony et al., 2021). Third, attitudes may be necessary for e-learning on students' interests (Mudjijanti & Srimulyani, 2023). If students' attitudes are negative on online exams, students' interests may be negatively affected. Fourth, negative attitudes can highlight the inequalities in the testing process due to unequal access to reliable Internet and technology (Karunarathne & Wijewardene, 2021). More clearly, if attitudes toward online assessment and evaluation are below the expected level, this may be caused by inequality in the education system. Lastly, Titarenko et al. (2020) pointed out the limitations of online testing in fields that require hands-on experience, such as physical education. So, negative attitudes can result from inadequate or limitations of online testing. The research suggests that understanding and addressing students' attitudes towards online exams is crucial for practical assessment and evaluation in higher education. It can help identify areas of improvement, enhance student satisfaction, and ensure the integrity of the assessment process.

## **5. CONCLUSION AND RECOMMENDATIONS**

This text discusses university students' attitudes toward online exams in the context of the COVID-19 pandemic. It highlights the shift to distance education and the challenges institutions, teachers, and students face in adapting to online learning. The importance of considering students' attitudes towards online exams is emphasized, as attitudes can influence academic engagement, achievement, and the adoption of e-learning. The study presents the development and analysis of a scale to measure students' attitudes toward online exams, including factor analysis and reliability testing. The findings indicate that the scale is reliable for assessing students' attitudes. Analyses results, according to item path covariances, show that lecturers have been the most important items on the scale. Moreover, the examination process should be considered according to university students' abilities and cognition. The text suggests further research and qualitative studies on students' attitudes toward online testing.

University students' attitudes towards testing and evaluation in online exams are one of the issues that should be emphasized in education. The adequacy of the student's achievements due to their education is determined by the exams to be administered. For

Arun, K. et al. (2023). A scale development to determine university students' attitudes to online exams assessment. *Advanced Education*, 23, 157-169. DOI: 10.20535/2410-8286.283028

this reason, online exams are of great importance to students. Moreover, path analysis results show that even though technological achievements are important, the most effective items are still related to the construction of the exams itself and support from real humans and lecturers. So, universities must prepare their lecturers as well as develop a good technical infrastructure because lecturers and university professors are the most credible factors in students' attitudes to online learning.

The scale used in this study was carried out on associate degree students, and it can be used in research conducted with undergraduate students. Moreover, there also needs to be more qualitative and quantitative research regarding examining students' attitudes toward e-testing. In the post-pandemic period, the system and the method of administration will be developed with more rigorous studies, considering the scale items created in universities where online education continues in some courses and exams are held online.

As practical implications, it is crucial to understand the attitudes and make them positive to universities. Otherwise, students tend to cheat more and even lose interest in online education. Moreover, determining university students' attitudes to assessment and evaluation in online exams can shed light on inequalities between students and testing quality (including limitations). In a nutshell, by evaluating the students' attitudes to the assessment of exams, university management can prevent cheating, inequalities, lousy quality, and loss of interest; in the meantime, by increasing attitudes, management can increase student satisfaction and education quality.

## REFERENCES

- Abun, D., Magallanes, T., & Incarnacion, M. J. (2019). College Students' Cognitive and Affective Attitude toward Higher Education and Their Academic Engagement. *International Journal of English Literature and Social Sciences*, 4(5), 1494–1507. <https://doi.org/10.22161/ijels.45.38>
- Afacan Adanır, Dr. G., İsmailova, Assoc. Prof. Dr. R., Omuraliev, Prof. Dr. A., & Muhametjanova, Assist. Prof. Dr. G. (2020). Learners' Perceptions of Online Exams: A Comparative Study in Turkey and Kyrgyzstan. *The International Review of Research in Open and Distributed Learning*, 21(3). <https://doi.org/10.19173/irrodl.v21i3.4679>
- Ali, I. L., & Iftikhar, M. (2021). Comparative Analysis of Students' Satisfaction Regarding Online Vs Traditional Examination at Postgraduate Level in University of Agriculture Faisalabad. *International Journal of Social Studies*, 1(1), 09–13. <https://doi.org/10.55627/ijss.01.1.0111>
- AlAdl, Abdelrahman. (2020). Using Electronic Tests Versus Pen And Paper Tests: The Experience Of Delta University. *مجلة كلية التربية المنصورة*, 110, 31-45. <https://doi.org/10.21608/maed.2020.147690>
- Alruwais, N., Wills, G., & Wald, M. (2018). Advantages and Challenges of Using e-Assessment. *International Journal of Information and Education Technology*, 8(1), 34–37. <https://doi.org/10.18178/ijiet.2018.8.1.1008>
- Basuony, M. A. K., EmadEldeen, R., Farghaly, M., El-Bassiouny, N., & Mohamed, E. K. A. (2021). The factors affecting student satisfaction with online education during the COVID-19 pandemic: An empirical study of an emerging Muslim country. *Journal of Islamic Marketing*, 12(3), 631–648. <https://doi.org/10.1108/JIMA-09-2020-0301>
- Boitshwarelo, B., Reedy, A. K., & Billany, T. (2017). Envisioning the use of online tests in assessing twenty-first century learning: A literature review. *Research and Practice in Technology Enhanced Learning*, 12(1), 16. <https://doi.org/10.1186/s41039-017-0055-7>

- Bozkurt, A., Jung, I., Xiao, J., Vladimirschi, V., Schuwer, R., Egorov, G., ... Paskevicius, M. (2020). A global outlook to the interruption of education due to COVID-19 pandemic: Navigating in a time of uncertainty and crisis. *Asian Journal of Distance Education*, 15(1), 1-126. <https://doi.org/10.5281/zenodo.3778083>
- Brallier, S., A. Schwanz, K., J. Palm, L., & N. Irwin, L. (2015). Online Testing: Comparison of Online and Classroom Exams in an Upper-Level Psychology Course. *American Journal of Educational Research*, 3(2), 255–258. <https://doi.org/10.12691/education-3-2-20>
- Brown, T. A. (2015). *Confirmatory factor analysis for applied research* (2nd ed.). Guilford Press.
- Byrne, Barbara M. (2010). *Structural Equation Modeling with AMOS; Fundamental Concepts, Implementation and Programming*, 2nd ed. New York: Routledge Taylor and Francis Group.
- Cakiroğlu, O.Ç. , Baykal, Ü. (2021). Development and psychometric properties of the attitude scale towards female employees in health institutions. *Journal of Advanced Nursing*, 77 (7). <https://doi.org/10.1111/jan.14859>
- Daviran, A. (2015). Investigation of Impact of Educational Attitudes of Students and Teachers on Academic Achievement of Third Grade Middle School Students in Zanjan. *International Journal of Academic Research in Progressive Education and Development*, 3(4), Pages 403-409. <https://doi.org/10.6007/IJARPED/v3-i4/1378>
- DeVellis, Robert F., Thorpe, Carolyn, T. (2022). *Scale development: theory and applications*. SAGE Publications, Inc., London. ISBN 9781544379340.
- Dikmen, M., (2020). The Mediating Role of Medical Students' Attitudes towards Distance Education in the Relationship between E-Learning Styles and Academic Achievements. *Journal of Educational Issues*, 6(2). <https://doi.org/10.5296/jei.v6i2.17789>
- Donovan, J. Mader, C. ve Shinsky, J. (2007). Online vs. Traditional Course Evaluation Formats: Student Perceptions. *Journal of Interactive Online Learning*, 6(3), 158-180. <https://www.ncolr.org/jiol/issues/pdf/6.3.2.pdf>
- Emin, M. N. (2020, April). Coronavirus outbreak and emergency education. SETA Perspective, (Issue 268).
- Gamage, K. A. A., Pradeep, R. G. G. R., & De Silva, E. K. (2022). Rethinking Assessment: The Future of Examinations in Higher Education. *Sustainability*, 14(6), 3552. <https://doi.org/10.3390/su14063552>
- George, D. ve Mallery, P. (2001). *SPSS for Windows: step by step*. Allyn & Bacon, USA.
- Gülbahar, Y. (2013). E-evaluation. In K. Cagiltay, Y. Goktas. (Ed.), *Fundamentals of Instructional Technologies: Theories, Studies, Trends*, (pp.651-663). Ankara: Pegem Academy Publishing.
- Halvaşı, B. (2019). Attitudes of Pre-service Music Teachers Studying in Undergraduate Programs in Turkey Towards Piano Courses. *Journal of Education and Training Studies*, 7(2), 142. <https://doi.org/10.11114/jets.v7i2.3844>.
- Hermanto, Y. B., & Srimulyani, V. A. (2021). The Challenges of Online Learning During the Covid-19 Pandemic. *Jurnal Pendidikan Dan Pengajaran*, 54(1), 46. <https://doi.org/10.23887/jpp.v54i1.29703>
- Huerta, A. H., & Britton, T. (2022). The Nexus of Carcerality and Access and Success in Postsecondary Education. *American Behavioral Scientist*, 66(10), 1311–1318. <https://doi.org/10.1177/00027642211054820>
- Jia, J., & He, Y. (2022). The design, implementation and pilot application of an intelligent online proctoring system for online exams. *Interactive Technology and Smart Education*, 19(1), 112–120. <https://doi.org/10.1108/ITSE-12-2020-0246>
- Karakuş, G. (2022). Scale Development Study on University Students' Attitudes Towards Online Exams. *Afyon Kocatepe University Journal of Social Sciences*, 24(1). <https://doi.org/10.32709/akusosbil.887141>
- Kartallıoğlu, N. (2022). The perceptions of international students learning Turkish through distance education on Turkish language course and language skills: A metaphor study. *Journal of*

- Arun, K. et al. (2023). A scale development to determine university students' attitudes to online exams assessment. *Advanced Education*, 23, 157-169. DOI: 10.20535/2410-8286.283028
- Educational Technology & Online Learning* 5(4), 1077-1093. <https://doi.org/10.31681/jetol.1154079>
- Karunarathne, G. D. D. T., & Wijewardene, L. (2021). Online Assessments: Their Importance in Higher Education. *Advances in Social Sciences Research Journal*, 8(12), 308–316. <https://doi.org/10.14738/assrj.812.11448>
- Kavas G. (2009). Effects of Video-Assisted Web-Based Peer Review System on Microteaching Practices: Example of Computer Education Candidates. Master Thesis, Marmara University, Istanbul.
- Kholid, M. N., Diptasary, F. A. A., & Tumewang, Y. K. (2021). An Integrated Model to Predict Cheating on Online Exam Among Accounting Students: Does Islamic Religiosity Matter? *Jurnal Reviu Akuntansi Dan Keuangan*, 11(3), 566–585. <https://doi.org/10.22219/jrak.v11i3.17689>
- Linden, K., & Gonzalez, P. (2021). Zoom invigilated exams: A protocol for rapid adoption to remote examinations. *British Journal of Educational Technology*, 52(4), 1323–1337. <https://doi.org/10.1111/bjet.13109>
- Luttrell, A., & Sawicki, V. (2020). Attitude strength: Distinguishing predictors versus defining features. *Social and Personality Psychology Compass*, 14(8). <https://doi.org/10.1111/spc3.12555>
- Means, B., & Neisler, J. (2020). Suddenly Online: A National Survey of Undergraduates during the COVID-19 Pandemic. Digital Promise. <https://eric.ed.gov/?id=ED610781>
- Ministry of Health, (2020). <https://covid19.saglik.gov.tr/TR-66300/covid-19-nedir-.html>
- Mudjjjanti, F., & Srimulyani, V. A. (2023). The Impact of E-Learning on Student Interest during the Covid-19 Pandemic. *European Journal of Education and Pedagogy*, 4(3), 135–142. <https://doi.org/10.24018/ejedu.2023.4.3.693>
- Reedy, A., Pfitzner, D., Rook, L., & Ellis, L. (2021). Responding to the COVID-19 emergency: Student and academic staff perceptions of academic integrity in the transition to online exams at three Australian universities. *International Journal for Educational Integrity*, 17(1), 9. <https://doi.org/10.1007/s40979-021-00075-9>
- Reeves, T. C. (2000). Alternative Assessment Approaches for Online Learning Environments in Higher Education. *Journal of Educational Computing Research*, 23(1), 101–111. <https://doi.org/10.2190/GYMQ-78FA-WMTX-J06C>
- Rhine, R. J., & Severance, L. J. (1970). Ego involvement, inconsistency, source credibility, and attitude change. *Journal of Personality and Social Psychology*, 16 (2), 175–190. <https://doi.org/10.1037/h0029832>
- Shakah, G. H., Al-Oqaily, A. T., & Alqudah, F. (2019). Motivation Path between the Difficulties and Attitudes of Using the E-Learning Systems in the Jordanian Universities: Ajloun University as a Case Study. *International Journal of Emerging Technologies in Learning (iJET)*, 14(19), pp. 26–48. <https://doi.org/10.3991/ijet.v14i19.10551>
- Shraim, K. (2019). Online Examination Practices in Higher Education Institutions: Learners' Perspectives. *Turkish Online Journal of Distance Education*, 20(4), 185–196. <https://doi.org/10.17718/tojde.640588>
- Sijtsma K. (2009). On the Use, the Misuse, and the Very Limited Usefulness of Cronbach's Alpha. *Psychometrika*, 74(1), 107–120. <https://doi.org/10.1007/s11336-008-9101-0>.
- Sirakaya, M., Sirakaya, D. A., & Çakmak, E. K. (2015). Investigation Of The Level Of Distance Education Students' Attitude Towards Online Exam [Uzaktan Eğitim Öğrencilerinin Çevrimiçi Sınava Yönelik Tutum Düzeylerinin İncelenmesi]. *Kastamonu Eğitim Dergisi*, 23(1), Article 1.
- Stowell, J. R., & Bennett, D. (2010). Effects of Online Testing on Student Exam Performance and Test Anxiety. *Journal of Educational Computing Research*, 42(2), 161–171. <https://doi.org/10.2190/EC.42.2.b>

- Stradiotová, E., Némethová, I., & Štefančík, R. (2022). What we know after the pandemic. online and face-to-face testing in comparative perspective. *Advanced Education*, 4–21. <https://doi.org/10.20535/2410-8286.270182>
- Şenel S., & Şenel H.C. (2021). Remote Assessment in Higher Education during COVID-19 Pandemic. *International Journal of Assessment Tools in Education*, 8(2), 181 - 199, 10.06.2021. <https://doi.org/10.21449/ijate.820140>
- Tabachnick, B.G. & Fidell, L.S. (2001). *Using Multivariate Statistics*. 4th Edition, Allyn and Bacon, Boston.
- Tarantini, C., Brouqui, P., Wilson, R., Griffiths, K., Patouraux, P., & Peretti-Watel, P. (2019). Healthcare workers' attitudes towards hand-hygiene monitoring technology. *Journal of Hospital Infection*, 102(4), 413–418. <https://doi.org/10.1016/j.jhin.2019.02.017>
- Titarenko, S., Tsys, D., Loboda, V., Khlus, N., Buzhyna, I., Kurilova, V., Butenko, H., Tsys, N., & Kasyan, A. (2020). Improving the Quality of Physical Education Classes Using Google Services in Higher Educational Institutions. *Universal Journal of Educational Research*, 8(11), 5081–5091. <https://doi.org/10.13189/ujer.2020.081108>
- Ünal, A., & Altuğ, F. (2021). Evaluation of Online Practical Courses and Exams from the Students' Perspectives of Physiotherapy and Rehabilitation Department: Sample of Pamukkale University. *Gevher Nesibe Journal IESDR*, 6(15), 73–79. <https://doi.org/10.46648/gnj.284>
- Yamamoto, G.T, & Altun, D. (2020). Coronavirus and the Unstoppable Rise of Online Education, *Journal of University Studies*, 3 (1), 25-34.
- Yilmaz, E. O., & Toker, T. (2022). Analysing the Effects of Assessment and Evaluation Applications and Exam Formats in Distance Education. *International Journal of Psychology and Educational Studies*, 9(1), 165–176. <https://doi.org/10.52380/ijpes.2022.9.1.691>
- WHO (2020). <https://www.who.int/emergencies/diseases/novel-coronavirus-2019/global-research-on-novel-coronavirus-2019-ncov>

### **Funding**

The author(s) reported there is no funding associated with the work featured in this article.

### **Conflict of interest**

No potential conflict of interest was reported by the authors.

Received: June 26, 2023

Accepted: December 18, 2023