



www.ijte.net

Modeling Development and Validation of Metaverse Attitude Scale

Ömer Kırbaş 
Ministry of National Education, Turkey

Fatih Doğan 
Çanakkale Onsekiz Mart University, Turkey

To cite this article:

Kırbaş, O. & Doğan, F. (2023). Modeling Development and validation of Metaverse Attitude Scale. *International Journal of Technology in Education (IJTE)*, 6(2), 155-186. <https://doi.org/10.46328/ijte.363>

The International Journal of Technology in Education (IJTE) is a peer-reviewed scholarly online journal. This article may be used for research, teaching, and private study purposes. Authors alone are responsible for the contents of their articles. The journal owns the copyright of the articles. The publisher shall not be liable for any loss, actions, claims, proceedings, demand, or costs or damages whatsoever or howsoever caused arising directly or indirectly in connection with or arising out of the use of the research material. All authors are requested to disclose any actual or potential conflict of interest including any financial, personal or other relationships with other people or organizations regarding the submitted work.



This work is licensed under a Creative Commons Attribution-NonCommercial-ShareAlike 4.0 International License.

Modeling Development and Validation of Metaverse Attitude Scale

Ömer Kırbaş, Fatih Doğan

Article Info

Article History

Received:

23 September 2022

Accepted:

01 April 2023

Keywords

Metaverse

Attitude

Validity

Reliability

Scale development

Abstract

This study is an attempt to develop a reliable and valid measurement tool to measure secondary school students' attitudes towards metaverse use. Therefore, the study reported the analyses related to metaverse attitude scale (MVAS). The content validity of the scale was ensured by an expert's view, and Exploratory Factor Analysis (EFA) and Confirmatory Factor Analysis (CFA) designed according to the Technology Adaptation Model (TAM) were employed to ensure its construct validity. The structural equation model was used to reveal the relationship across the variables. EFA was carried out with the data obtained from 251 5th, 6th, 7th, and 8th-grade secondary school students enrolled in public schools in a city in northwest Turkey. The results of EFA confirmed a 22-item three-factor model. Then, the three-factor model obtained from EFA was cross-validated through the use of CFA that proposed a 21-item 3-factor model. The fit indices for CFA were found as .05 for RMSEA, .049 for SRMR, .889 for GFI, .871 for AGFI, .9146 for NFI, .965 for CFI, and .916 for RFI. Besides, the results affirmed the proposed 21-item three-factor model theoretically and statistically. Structural equation modeling was used to determine the relationship across variables. Accordingly, secondary school students were identified to have positive responses towards cognitive and affective fields related to the metaverse. However, they could not transform these responses into behavioral field. As a result, the metaverse may be used in education since it is likely to observe the independent variables such as perceived usefulness, perceived ease of use and attitude towards use regarding the metaverse in secondary school students.

Introduction

Education plays a major role in the development of societies. While technological developments, which accelerated with the information revolution, affect people's daily lives, it is almost impossible not to get their share from these changes in education (Gökçe, 2008). Encountered in all areas of human life, technology paves the way for new trends with its use for educational purposes (Demirli, 2002). Distance education has been a hot topic with the developments in communication technologies in terms of making education more efficient, spreading, individualizing, and meeting the demand of the increasing population (Aydın, 2002). Students' access to educational resources is facilitated by supporting educational environments with technology (Miller, 1996). Thus, the interaction between students and teachers also becomes stronger. Educators and administrators also need to work together to boost student learning and streamline technology integration (Ibrahim and Shiring, 2022). In

addition, it motivates students to construct knowledge and learn to learn in environments where teachers serve as guides (Nitko, 1996). Thus, technology offers new opportunities for individual learning. Innovations in informatics play a significant role in daily life as they enrich human interaction, communication, and social connectedness. Three major waves of technological innovation have occurred around personal computers, internet access, and mobile devices for today's users. Technologies such as spatial, immersive virtual, and augmented reality, which is the fourth wave, are currently on the agenda (Kamenov, 2022). This wave is expected to create the paradigm of spatially ubiquitous computing with the potential to transform online education, online business, and entertainment. This paradigm is the metaverse (Mystakidis, 2022). Metaverse, in the sense of superiority, refers to a virtual world in which social-cultural activities are combined, consisting of the combined words of the meta and universe. Besides, the concept was used for the first time in Neal Stephenson's science fiction novel "Snow Crash" in 1992. Today, it also refers to a world where virtual and reality come together and gain value through social activities (Stephenson, 1992). Augmented reality and virtual reality are technological tools that have been used in every field recently (Batdı & Talan, 2019). Metaverse is expected to be used in various areas like these technologies (Tas and Bolat, 2022). The metaverse distinguishes itself in three ways from interconnected virtual reality and augmented reality. Firstly, working via VR has a physical and processing-oriented approach, yet metaverse has a strong side to socially serving sustainable content. Secondly, metaverse does not necessarily have to contain AR and VR technology, the system can maintain itself without them. Thirdly, the metaverse has an environment that can accommodate large numbers of people to strengthen social meaning (Park and Kim, 2022a).

Education is one of the most significant areas for the development of the metaverse universe and its spread to wider areas. Audio-visual-based education shows high potential with metaverse. Information can be transferred, and the information can be made permanent by repeating it with the training provided to the students. However, the most important factor in completing the education is to feel what is seen in writing while living. Kanematsu et al (2014) stated that it is difficult and dangerous to experience radiation. Moreover, they reported that radioactivity can be analyzed technically and scientifically thanks to the metaverse. As a result, they concluded that difficult and dangerous experiments and activities in education may be possible with metaverse. In addition, Tas and Bolat (2022) noted that Metaverse may be effective in learning expensive and dangerous experiments or subjects that cannot be directly observed as augmented reality (AR). Gartner (2022) suggested that approximately 30 % of people would spend 2 hours a day in the Metaverse environment by 2027 for education, socializing and entertainment. Therefore, the metaverse universe is of great importance to complete learning in education. Hence, more and more education researchers are expected to actively participate in meta-universe studies in education in the near future (Zhang et al., 2022).

Considering the studies on the metaverse universe, Park and Kim (2022a) examined the basic techniques and approaches of the metaverse universe and the basic methods of metaverse representatives in the fields of movies, games, and studies. They also summarized the limitations of the metaverse in terms of social implications and challenges. Choi (2022) demonstrated how different types of teleworking (with metaverse, without metaverse) could reduce the population pressure in megacities in different ways and offered practical suggestions to politicians to support these practices for strategy and managers. Park and Kim (2022b) identified the types of

worlds in the metadata to provide a gaming experience to users. They also highlighted the positive relationship between learning motivation and game experience. They presented examples of 5 different virtual worlds on the metaverse base. These virtual worlds are considered as survival, maze, multiple choice, race/jump, and an escape room. The results suggested that education has changed significantly with the COVID-19 epidemic and that new methods to satisfy educators and students should be explored here. The results also showed that metaverse is the method that can be presented as an alternative. With the use of the metaverse in education, the absence of time and space restrictions may provide equal opportunities for those who suffer from physical problems and environments (such as disaster areas). Suh and Ahn (2022) conducted a study with primary school students on employing the metaverse for a student-centered constructivist education after the pandemic period. Examining the related literature on the subject, the researchers reached primary school students in Korea through using 18 items for the measurement of each factor in the meta database and made statistical analyzes including the difference of means with the t-test. The analysis results revealed that 97.9% of the students had experiences with the metaverse and that 95.5% of them thought it was closely related to their daily lives. Gomes and Klein (2013) reported a design study in metaverse with 6 volunteer students who were requested to have a design with the opportunities. Gomes and Klein (2013) stated that the students had some problems while they were working and they also stated that the students had little competence for teamwork and that the lack of devices suitable for the metaverse second life environment led to some problems. Jovanovic and Milosavljevic (2022) introduced the VoRtex application they developed to create an educational experience in the virtual world. The purpose of designing VoRtex was to support collaborative learning activities with the virtual environment. VoRtex was an accessible application in which modern technology via metaverse is used with the support of education standards. Finally, the researchers analyzed the advantages and disadvantages of collaborative learning with the metaverse platform and real-world classroom environments. Barry et al. (2015) introduced a blink system for avatars in the “problem-based learning” class in the metaverse environment. The emotional reactions of university students to various problems they were requested to discuss in the project, which included simple and difficult problems, were measured. In this study including mathematical problems, students were left alone with question sessions of 10 minutes. After completing the study, the students were asked to respond the questions by conducting a questionnaire. Accordingly, the results affirmed that difficult questions would make the students' emotions unstable and the number of blinks increased. Lee and Hwang (2022) proposed a system that includes virtual reality and metaverse in education to compensate for the deficiencies in the distance applied education models available today. An aircraft maintenance simulation was developed for the system proposed in the study. The findings suggested that 40 volunteers did not have preliminary knowledge about aircraft maintenance. The application was conducted and the data were obtained. The analysis results indicated that the recommendations were suitable for the use of the systems they confirmed a sense of spatial presence.

Kye et al. (2021) described four types of the metaverse universe to explain the potential and limitations of metaverse in educational applications. They asserted the potential of the metaverse to be a new educational environment as follows; “*A space for social communication, greater freedom to create and share, and new experiences through virtualization*”. Locurcio (2022) emphasized the necessity of using metaverse and artificial intelligence in the field of dental education. Jaramillo-Mujica et al. (2017) put forward the idea of designing a 3D environment and metaverse environment to encourage the learning of physics engineering students. Besides, Huh

(2022) analyzed the computer-based test application for Korea's medical licensing exam to contribute to the metaverse in medical education. Diaz (2020) investigated the metaverse universe for hybrid and mobile learning. The researchers found that the traditional model varied from being static to more dynamic, and the students are at the center in the inverted classroom. In addition, Tas and Bolat (2022) presented an bibliometric report on metaverse. Accordingly, the number of studies on the metaverse has generally increased in recent years. Furthermore, they also found that the keywords such as virtual reality, second life and augmented reality are mostly used in the studies conducted on the use of metaverse in education. Likewise, Saritas and Topraklıkoğlu (2022) carried out a literature review with 22 different documents on the concepts of Metaverse and identified the aim of each articles in the research and their contributions to the field of education. While some researchers were working to introduce the metaverse, others created a metaverse universe themselves. The study also depicted the presence of studies on postgraduate-undergraduate education in the field of education. The relevant literature involves a scale development (5th and 6th grade) study for primary school students in South Korea. However, there is no such a study specifically published on developing a measurement tool to examine the use, approaches, and attitudes of secondary school students for metaverse.

Problem Status

In recent years, there have been tendencies in education for students to receive education independent of time and place. The reason why this model, known as distance education, is preferred is that students do not fall behind due to their current education or health reasons. Many regions have provided distance education especially during the covid19 period. Digital education environments used in distance education activities have emerged during the epidemic process. Distance education has become a part of life during this period when digitalization has reached its peak (Durak et al, 2020). Today, countries in an effort to move forward in the field of education combine education and technology as a whole. The reason why these countries use technology more actively in learning environments is to provide students with an opportunity to learn in practice, research-based, and more fun ways. Thus, technological developments and teaching materials are changing and developing day by day. Thus, there is a need to search on the use of metaverse, a product of technology that is prone to use in education.

Offering a realistic experience among educational materials, metaverse allows students to get to know virtual reality better. Although there are no widespread studies on the metaverse in related literature yet, several education institutions in different countries have conducted studies on the metaverse field. The lack of studies on secondary school students in the relevant literature and the inability to obtain measurement tools for students' intentions, behaviors, and attitudes towards the metaverse made it necessary to develop a new scale to contribute to the literature. Accordingly, the problem statement of the study was noted as “What is the relationship across the variables affecting the secondary school students' use of metaverse as a learning environment?”

On the other hand, the following sub-problems were provided,

- ✓ Is the scale developed for the secondary school students' metaverse attitudes according to the TAM model valid and reliable?
- ✓ What are the variables in the scale developed for the secondary school students' metaverse attitudes according to the TAM model?

Purpose and Importance of the Research

It is widely known that technology is an inseparable part of our daily lives and plays a significant role in facilitating lives through diversifying and differentiating according to their needs. Rapid advances in technology are not only related to science, but also have a high connection with education (Yıldırım, 2020). Various concepts such as AR/VR and Metaverse, which are technological tools, have emerged with the changes in education systems from the past to the present. Due to the increasing importance of education with technology, societies have always attempted to create more satisfactory and contemporary education systems. Thus, the adaptation of technological products to the field of education has always been prioritized. Davis (1989) argued that user acceptance of new technologies depends on the variables such as perceived usefulness and perceived ease of use. Hence, the success of information systems may not only be evaluated according to technical and managerial qualities, but also vary across the demographic characteristics, expectations and perceptions of the people who use the system, and the perceptions of the users can primarily have an effect on this success. Thus, individuals' attitudes and intentions may directly affect the behaviors. As a result, behavioral changes with the determination of an attitude or intention can be predictable.

However, psychological variables such as attitude, intention, perception, and anxiety, which are used to predict behaviors, cannot be measured directly. Such psychological variables can only be determined by observing behaviors, question lists, interviews, projective techniques, or by individuals' responses to various questions in a measurement tool. Thus, individuals' behavioral changes can be predicted through measuring psychological variables and detailed information can be obtained about adaptation processes. Therefore, this study aims at developing a measurement tool to examine the processes of secondary school students' acceptance of the metaverse, one of the latest products of technology, as a new learning environment. The dependent and independent main variables of the TAM model were taken into account during the development of the measurement tool. The tool is capable of measuring individuals' responses in cognitive, affective and behavioral fields related to the metaverse. Accordingly, perceived usefulness, which is one of the main variables of TAM, is defined as the degree of belief that a person will increase in performance through using a certain system. Perceived ease of use, another main variable, is described as the degree of personal belief that a person's use of a particular system requires effort. Attitude, which is another dimension of the model and which is formed as a result of the accumulation of emotions and ideas, refers to the positive or negative reaction of the individual to the system. Intention is the main determinant of an individual's behavior and indicates the possibility of an individual to perform a certain behavior. The model suggests that ease of use, perceived usefulness, and attitude may be effective on individuals' behavioral intentions.

Selection of TAM

There are some important models in the relevant literature to examine the assimilation of information technologies such as the Theory of Reasoned Action, the Theory of Planned Behavior (Mathieson, 1991), the Technology Acceptance Model (Davis, 1989), and the Unified Theory of Acceptance and Use of Technology (Guo and Liu, 2013). The foundations of these models are based on the Theory of Reasoned Action (TRA). TRA suggests that

an individual can predict their actions based on pre-existing attitudes and behavioral intentions. TAM used in the study is also a model that includes the acceptance of information technologies based on the TRA model (Moon and Kim, 2001). Landry et al. (2006) noted that TAM is suitable for use in academic environments. In addition, many factors should be investigated, including the variables suggested by TAM, when examining whether users are satisfied with applications for computers and their derivatives (Adams et al., 1992). Therefore, the TAM model was deployed to examine the research problem regarding students' attitudes, intentions, and perceived benefits.

Method

This research is based on the exploratory sequential mixed research method, in which quantitative and qualitative research is used together for middle school students' attitudes towards the metaverse. Cresswell (2013) stated that the mixed method should combine or integrate qualitative and quantitative data. The mixed method suggests that qualitative and quantitative data can be used simultaneously to eliminate the lack of a data group that arises from using only the data source. According to Cresswell (2013), the exploratory sequential mixed method, which is a theme of the mixed method, starts with the data collection method of the research and explores the participants' perspectives. A quantitative measurement tool is created to be used in the second stage with the analysis of the elicited data (Cresswell, 2013). In this regard, focus group interviews were conducted with a group of secondary school students to create an item pool. At the end of the interview, opinions that might be attitude sentences about metaverse were noted and contributed to the creation of the items. Some items were added by a literature review and panel system. Expert opinion was sought to determine the extent (scope validity) of the items in the scale and to help the measurement tool reach the target (Tekin, 1977). Factor analysis was performed to identify the construct validity of the scale. Factor analysis is a method that reduces the number of items related to each other by bringing them together. The purpose of factor analysis is to reduce the number of variables and classify them according to the relationship across variables (Kalaycı, 2010).

Research Prospectus Outlined

This research aims to develop a valid and reliable tool that will serve to measure secondary school students' attitudes towards the metaverse. The data were collected from a total of 251 5th, 6th, 7th, and 8th-grade students studying in a public secondary school in a city located in Northwest Turkey. Table 1 displays the steps followed for the development of the tool, which will help to understand the research more easily.

Table 1. The Steps followed in the Study

Sub problem	Pathway	Stage	Process
Sub problem 1	Content Validity	Stage 1	Items were collected from the TAM literature and through focus group interviews. The draft MVAS was created with 54 items and its content validity was ensured by expert opinions.
		Stage 2	The CVR and CVI values of each item in the form were calculated as a result of the opinions of the experts. Items numbered "7-18-24-32-51" were removed from the draft

Sub problem	Pathway	Stage	Process
Subproblem 2			MVAS. Face validity was also provided with a group of secondary school students.
	Construct validity	Stage 3	The construct validity of the form was provided through EFA. It was conducted with 251 secondary school students. Items "1, 2, 3, 5, 6, 7, 8, 9, 10, 12, 14, 15, 17, 24, 26, 27, 29, 30, 35, 42, 43, 44, 46, 47, 48 and 49" were removed from the draft MVAS
	Control of items	Stage 4	ANOVA Tukey's Nonadditivity analysis was carried out to check their relationship with each other and the homogeneity of the items constituting the MVAS. Whether the phenomenon can be measured appropriately with the measurement tool was determined by Hotelling's T-Squared analysis. Sequence validity of the items in the measurement tool was performed by Intraclass correlation coefficient
	Confirmation of construct validity	Stage 5	The confirmation cross-validity of the MVAS was performed with 211 secondary school students. The data were obtained from a different sample from the sample group used in the pilot application. Item "18", which could not meet the construct validity assumptions, was removed from the MVAS. Convergent and discriminant validity was also ensured.
	Reliability	Stage 7	Cronbach's alpha coefficients were computed for each sub-factor and overall, the scale.
	Modeling	Stage 8	The hypotheses were checked according to TAM and the data-model fit was tested
Result	Stage 9	A valid and reliable MVAS was prepared. The MVAS contained 22 productive Likert-type items	

The final MVAS was obtained by applying the procedures depicted in Table 1 respectively. Table 2 shows the MVAS containing 22 productive Likert-type items.

Table 2. Metaverse Attitude Scale for the Secondary School Students

Dimensions	Code	Items	Strongly agree	Agree	Neither agree nor disagree	Disagree	Strongly disagree
PU	PU1	Item45: With Metaverse technology, more realistic virtual environments can be created.	1	2	3	4	5
	PU2	Item40: With Metaverse, experiments in science class become quite easy.	1	2	3	4	5
	PU3	Item4: Gaming is fun in the Metaverse	1	2	3	4	5

Dimensions	Code	Items	Strongly agree	Agree	Neither agree nor disagree	Disagree	Strongly disagree
		universe					
	PU4	Item25: With the Metaverse, experiments can be performed more easily.	1	2	3	4	5
	PU5	Item33: We can be more creative with Metaverse.	1	2	3	4	5
	PU6	Item23: Metaverse requires the Internet.	1	2	3	4	5
	PU7	Item11: Metaverse is an emerging technology.	1	2	3	4	5
	PU8	Item22: Metaverse is a virtual reality tool.	1	2	3	4	5
	PU9	Item34: I am aware that the Metaverse will be more prevalent in the future.	1	2	3	4	5
	PU10	Item13: I think Metaverse will expand to wider areas in the future.	1	2	3	4	5
	PEU1	Item41: Thanks to the metaverse universe, I can be more successful in my lessons.	1	2	3	4	5
	PEU2	Item28: I want to study with Metaverse.	1	2	3	4	5
	PEU3	Item16: My interest in the lesson increases when the lesson is taught with Metaverse.	1	2	3	4	5
PEU	PEU4	Item21: Lesson topics covered in Metaverse are more fun.	1	2	3	4	5
	PEU5	Item19: Thanks to Metaverse, I can study without going to school.	1	2	3	4	5
	PEU6	Item20: The knowledge which learn with Metaverse is quite permanent.	1	2	3	4	5
	UA1	Item32: We get lazy with the metaverse.	1	2	3	4	5
	UA2	Item31: Metaverse is a waste of time.	1	2	3	4	5
	UA3	Item37: Metaverse can interfere with the privacy of people.	1	2	3	4	5
UA	UA4	Item39: A negative situation that may arise in the metaverse universe can cause the death of a person.	1	2	3	4	5
	UA5	Item38: Metaverse can cause health problems in humans.	1	2	3	4	5
	UA6	Item36: The psychology of people using metaverse applications may be impaired.	1	2	3	4	5

Research Model and Hypotheses

This sections covers the relations across the variables in terms of examining the reflections of the secondary school students' attitudes towards the use of Metaverse as a learning environment in education within the scope of the TAM. Figure 1 displays the model used in the present study.

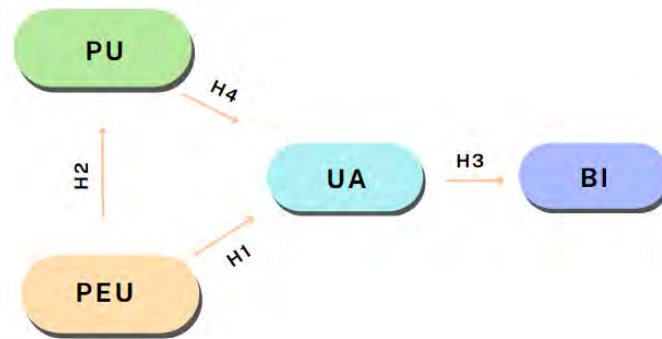

Figure 1. Research Model and Hypotheses

The research model was designed by means of the dependent and independent variables in TAM. Accordingly, the hypotheses (H1, H2, H3 and H4) were structured as follows:

- ✓ Hypothesis 1 (H1): Secondary school students' perception of ease of use regarding metaverse as a learning environment has a positive effect on their attitudes towards the use of this technology (PEU's effect on UA)
- ✓ Hypothesis 2 (H2): Secondary school students' perception of ease of use regarding metaverse as a learning environment has a positive effect on their perceived usefulness (PEU's effect on PU).
- ✓ Hypothesis 3 (H3): Secondary school students' attitudes towards the use of metaverse as a learning environment have a positive effect on their intention to accept this technology (UA's effect on BI).
- ✓ Hypothesis 4 (H4): Secondary school students' perceived usefulness regarding metaverse as a learning environment has a positive effect on their attitudes towards the use of the metaverse (PU's effect on UA).

TAM is a model that explains the causal relationships between perceived usefulness, perceived ease of use, attitude, intention to use, and actual use. The model points that the perception of ease of use and the perceived usefulness have a significant effect on individuals' intention to use information technology (Davis,1989). Various external variables such as social factors, design features, image, job fit, output quality, demonstrability, experience and volunteering were added to the model and the effect of subjective norms on the dimensions of the classical model was explained (Venkatesh ve Davis, 2000). Thus, more than one TAM with many independent variables in the literature was created. In the present study, it was excluded from the model as it may lead to Fishbein paradigms in external variables (Fishbein, 1966). Since metaverse technology is not widely used in education activities today, the dependent variable actual use representing the behavioral field of TAM was excluded from the research model. Therefore, the simplest TAM was used in the creation of the research model and the establishment of the relevant hypotheses.

Data Collection Process for EFA

This study examined secondary school students' attitudes towards the metaverse. To start the study, firstly, the publications on metaverse in the literature were examined. However, the related literature lacks a measurement tool whose validity and reliability have been proven. For this reason, the MVAS was developed and used to determine the secondary school students' attitudes towards the metaverse. Before starting the data collection process, secondary school students were informed on semantic WEB and metaverse for a short time in each classroom within the scope of Information and Technology course. Semantic WEB and meta-universe were clarified and students were provided awareness of their functions. Great attention was paid to include students who use VR Box in their lessons, in any project or in any game, or those who are familiar with augmented reality technology. A group of students with VR Box experience, who are not included in the sample group, were requested to write an essay describing their usage skills, emotions, thoughts, and their relationship with technology regarding metaverse. The texts written by 12 students were read. The sentences suitable for the scale were arranged and included in the draft MVAS. In addition, criteria items suitable for the research by the TAM were searched in the literature. Special importance was attached to reflect the cognitive, affective, and behavioral dimensions of the items thought to be included in the draft MVAS. Negative items were also included in the scale. The items in the study were designed according to the operational variables of the TAM model. TAM is a moving model that depends on the motive of intention, belief, and behavior (Sun and Zhang, 2006). In this regard, phenomena that may affect behavior were modeled within the scope of technology use. These variables were cognitive responses (variables: perceived usefulness, PU and perceived ease of use, PEU), affective responses (variable: user attitude, UA), and behavioral responses (variable: behavioral intention, BI). Afterwards, an item pool consisting of 54 Likert-type attitude items was created. The draft MVAS was presented to field experts of 14 people. The items in the draft MVAS were evaluated by an expert in terms of language, scope, and psychometrics. The draft MVAS, whose content validity was also ensured, was presented to the students for pilot application along with a personal information form containing some categorical variables.

Respondents' Demographic Profile for EFA

Population can be expressed as a community consisting of units that fit a certain definition, on which research will be conducted, or that constitute the study area of the research and can generalize the results (Özmen, 2000). The population consisted of 3650 secondary school students studying in the Dilovası district of Kocaeli province in Turkey during the 2021-2022 academic year. The sample of the study held 251 students who were chosen by a simple random sampling method. It is a sampling type in which each unit forming the population has an equal probability of being included in the sample or each unit has an equal chance of being selected and the units do not affect each other (Altunışık et al., 2012). The following formula prepared by Yamane (1967) based on the population size was used in determining the sample size.

$$n = \frac{(Nt^2pq)}{(d^2(N-1)+t^2pq)} \dots\dots\dots(1)$$

In Equation (1), N: Number of individuals in the target population (main mass), n: Number of individuals to be sampled, p: Probability of occurrence of the investigated event (0.10), q: the probability of not happening of the investigated event (0.90), d: ± the sampling error accepted according to the incidence of the event. (0.05), t: the theoretical value (1.96) found according to the t-table at a certain significance level. With the above-mentioned formula (1), the sample number was obtained as 134. However, 251 secondary school students were included in

the study. Accordingly, 119 (47.4%) of the 251 secondary school students participating in the study were girls and 132 (52.6%) were boys. Of all the students, 45 (17.9%) were the 5th graders, 47 (18.7%) the 6th graders, 60 (23.9%) the 7th graders, and 98 (39.4%) the 8th graders. The students were also asked whether they had personal computers and internet access at home. 213 (85%) of the students stated that they had the internet at home, and 38 (15%) did not have the internet at home. 97 (38.6%) students had a computer while 154(61.4%) did not. Besides, an answer was sought by asking about the level of students' knowledge about metaverse. It was ranked on 5 variables such as very little, little, moderate, good, and very good. The number of students who answered "very little" was 85 (33.7%), those who gave "a little" answer was 54 (21.4%), those with "moderate" answers were 83 (32.9%), the number of those who gave "good" answers 19 (7.5%) and those who stated it as "very good" was 11 (4.4%).

Data Collection Process for CFA

CFA analysis was conducted with 211 participants. The data were collected via google forms. Since data were collected to validate the scale, the number of questions about categorical data was not reduced in the study. It is assumed that scale development is suitable for its purpose as the research process is related to secondary school students.

Respondents' Demographic Profiles for CFA

Data were obtained from the sample group with the following demographic characteristics for CFA. 94 (44.54 %) of the secondary school students who provided feedback to the CFA analyses were girls and 117 (55.46 %) boys. The secondary school students giving feedback were in the 5th (44 students, 20.85 %), 6th (43 students, 20.37 %), 7th (51 students, 24.17 %) and 8th (73 students, 34.59 %) grades. When 130 (61.61 %) of the students did not have a computer at home, 81 (38.39 %) had computers in their homes. While 188 (89.09 %) students had permanent internet at home, 23 (10.91 %) did not. 67 of the students(31.75%) knew little about metaverse. While 73 (34.59%) students knew moderately. 5 students (2.36%)stated that their metaverse knowledge was very good.

Results and Discussion

Overview of Statistical Analyses

Statistical analysis in the study was carried out in 4 steps. In the first step, an expert opinion of 14 people was taken to ensure the validity of the draft MVAS content. In the second step, EFA was provided to explore the factor structure underlying the measurement tool. EFA was performed with principal component analysis through use of SPSS 21.0, and the interactions of the items with each other were also examined. In the third step, the structures of the factors obtained from EFA were confirmed by CFA (Yong and Pearce, 2013). CFA was achieved with the Analysis of Moment Structure (AMOS) 21 program using the maximum likelihood estimation (MLE) method. Hence, the combination and reflection validity of the variables were determined. Besides, the cronbach alpha coefficient was calculated for Likert items. In the last step of the study, hypotheses related to the variables of the TAM model were established and the validity of the hypotheses was examined.

Content Validity

Content validity ensures that items on the scale are necessary and that unwanted items are removed from the scale (Boudreau et al., 2001). In addition, it determines to what extent the developed items represent the attitude which is expected to measure. Thus, instead of using irrelevant concepts, it may be possible to reveal concepts with stronger representation (Ayre and Scally, 2014). In content validity, which is a method used to determine whether each item in the test is a sufficient or appropriate question to measure the behavior that is intended to be measured, one of the ways used for examination is expert opinions (Büyüköztürk, 2009). As a result, it is vital to cover the needs-oriented data with the expert opinions of each item in the scales (Yeşilyurt and Çapraz, 2018). Expert opinions were sought to ensure content validity. Gaps were left where the experts could make explanations in addition to the questions and they were requested to reflect their opinions. The draft of the experts whose opinions were taken to ensure the content validity of the scale is as follows;

- ✓ For the simplicity and intelligibility of the written language, one lecturer working at the Department of Turkish Education, Faculty of Education, Çanakkale Onsekiz Mart University (ÇOMU)
- ✓ One lecturer working in the Measurement and Evaluation Department, Department of Educational Sciences, Faculty of Education, ÇOMU,
- ✓ For the analysis of the items, four instructors working at the Department of Science Education, Department of Mathematics and Science, Faculty of Education, ÇOMU
- ✓ It was presented to a total of fourteen experts, eight of whom were science teachers working in institutions affiliated with the Ministry of National Education.

The experts in the study were determined by a convenient sampling method. The draft of the questions presented to the experts was also arranged as suggested by Yusoff (2019).

- ✓ The item is irrelevant to the measurement subject, it should be removed (1 point)
- ✓ The item is somewhat relevant to the subject being measured; it should be reviewed (2 points)
- ✓ The item is relevant to the subject being measured, but it should be slightly corrected (3 points)
- ✓ The item is very relevant to the subject being measured; the item must be found as a constant (4 points)

The higher the validity of the content on a scale, the more accurately the measurement of the targeted state will emerge. For this reason, it was tried to prevent taking wrong steps in the development of the scale with the qualitative and quantitative opinions taken from the experts. It is essential to find a quantitative criterion for estimating the validity of the scale. In content validity, the content validity index (CVI) and content validity ratio (CVR) are used as quantitative criteria. CVR is an internationally accepted criterion used to decide whether to include items in separate scales. CVI is defined as the average content validity rate of all items at the end of the scale. In short, CVR is used to determine whether each item is valid, while CVI is used to determine the relationship of each item to the scale (Shi et al., 2012). The content validity studies were carried out in six steps with the recommendation of Polit and Beck (2006). These six steps and their order are as follows;

- ✓ Preparation of content verification form
- ✓ Selecting a review panel with expert staff
- ✓ Content verification

- ✓ Examination of areas and items
- ✓ Calculation of scores for each item
- ✓ Finding CVR, I-CVI, and S-CVI values

Ayre and Scally (2014) report was used to calculate the CVR value, and Lynn (1986) and Polit and Beck (2006) reports were also used to find the CVI value. In addition, the CVR proposed by Lawshe (1975) in the development of the draft MVAS was calculated. Data were analyzed through using the interpretations suggested by Ayre and Scally (2014). Accordingly, the following equation was used

$$\text{CVR} = \frac{A}{N} - 1$$

N; The total number of experts, A; According to Yusoff's scoring (2019), it is the number of experts who make the "relevant" evaluation by giving 3 or 4 points to any item. The CVR value obtained at this stage is a statistical tool used as a criterion for the rejection or acceptance of some items. While taking the opinions of the experts who gave 3-4 points in the calculations, the opinions of the experts who gave 1-2 points were examined. The question "What is your suggestion?" to the expert who answered that the item should be corrected (2 points) was asked. In addition, the expert who answered that the item should be removed from the scale (1 point) was asked "why". According to the evaluations of Ayre and Scally (2014), $\text{CVR}_{\text{critical}} = \text{critical CVR}$, a positive value at the level of $\alpha = .05$ was used in the interpretation of the CVR value. Accordingly, the limit value for the CVR critical value was accepted as .51 in the evaluations of the experts. Accordingly, the CVR values of items 7, 18, 24, 32, and 51 were determined to be below the critical value and these items were removed from the draft MVAS under the strength of the opinions of fourteen experts at the $\alpha = .05$ significance level. On the other hand, since the CVR statement, which was first put forward by Lawshe (1975) and later revised by Ayre and Scally (2014), is based on the empirical approach, the calculations of content validity have been expanded by taking Yusoff (2019)'s suggestion into account in the present study. Yusoff (2019) suggested two separate CVI forms. These are the item-level content validity index (I-CVI VR), which helps define the scope index of the item, and the scale-level content validity index (S-CVI) that refers to general content validity. I-CVR was used to identify whether each item in the scale could be used as a criterion. On the other, the S-CVI value was calculated to determine whether the experts were compatible with each other. The S-CVI value, which examines the agreement of the expert opinions, can be calculated by using two methods. The first of these is S-CVI/Ave, where the mean of I-CVI of all items is known, while the other is S-CVI/UA, which belongs to the items marked as 3-4 points on the scale. S-CVI/UA is named as the universal agreement method content validity index. Lynn (1986) and Polit and Beck (2006) stated that the I-CVI value should be at least .75 or greater in studies involving five or more experts. In addition, the literature shows that S-CVI/Ave and S-CVI/UA values should be at least .8 for the general validity of the scale (Orts-Cortés et al., 2013). Herein, the I-CVI values of items 7, 18, 24, 32, and 51 in the draft MVAS were obtained as less than .78. Moreover, the S-CVI/Ave and S-CVI/UA values were found to be .93 and .84, respectively. Finally, the experts' views were converted into kappa values to eliminate the chance effect after the calculations and to prevent the occurrence of a situation where the experts could predict the I-CVI. The Kappa index (k^*) is a fit index indicating that the items are subject-oriented, clear, and understandable, beyond the possibility of being something other than their motivating feature (Wynd et al., 2003). In addition, the evaluation of the kappa value was carried out with the Kappa sequence suggested by Fleiss (1971). The Fleiss kappa scale describes as "Excellent $\geq .74$ ", "good between .60-.73", "moderate between .40-.59", and "poor $\leq .39$ " for each item in the

measurement tool. The equations used to calculate Kappa are as follows;

$$pc = \left[\frac{N!}{A!(N-A)!} \right] 0,5^N \quad \text{ve} \quad k = \frac{I-CVI-pc}{1-pc}$$

Here k; kappa coefficient, pc; random correlation coefficient, N; the number of experts, A; the number of experts who made a “relevant” assessment. Based on this, it was determined that the kappa values of items 7,18,24,32, and 51 were lower than .48. As a result of the calculations, five items from the 54-item draft measurement tool were removed from the scale since they could not provide the CVR, I-CVI, and kappa values. Thus, a 49-item MVAS was prepared in a 5-point Likert type with content validity (see Appendix A for expert system in content validity of draft MVAS).

Face Validity

After the content validity, face validity was performed to examine the simplicity of the language of the form and the clarity of the structure (Yusoff, 2019). The 49-item draft MVAS which ensured the content validity was presented to a panel group of 30 secondary school students (Yusoff, 2019). The suggestions in the form were evaluated as follows

- ✓ the item is not clear (1 point)
- ✓ the item is somewhat clear (2 points)
- ✓ the item is clear enough (3 points)
- ✓ and the item is very clear (4 points)

In addition, students were requested for information about each item. In Item-level face validity index (I-FVI) and scale-level face validity index based on the average method (S-FVI/Ave), and scale-level face validity index based on the universal agreement method (S-FVI/UA) indexes were calculated in face validity calculations. I-FVI value is the ratio of the respondents who give 3-4 points in the evaluation of the openness of an item to all respondents, and the S-FVI/Ave value is the average of the I-FVI value of all the items in the form and S-FVI/UA value is also the ratio of respondents who give 3-4 points to the clarity of an item in the whole form. If all respondents agree on an item, the universal agreement (UA) value is 1. The minimum acceptable values for I-FVI and S-FVI are .8 and .83, respectively. Ozair et al. (2017)'s recommendations were used in all calculations of face validity. I-FVI, S-FVI, S-FVI/Ave, and S-FVI/UA values were obtained as .91, .91, .93, and .83, respectively. Since there is no item eliminated from the draft MVAS as a result of face validity, a comparative table is not included here.

Construct Validity

After providing content validity, normality analyzes were performed to verify the structural validity of the 49-items draft MVAS. This study examined whether the data demonstrated normal distribution through using the skewness and kurtosis statistics, which are descriptive analysis methods. In normality tests, skewness and kurtosis values should be between -2 and +2 (George and Mallery, 2010). When these conditions are met in the scale, the data are considered to have a norm. The skewness and kurtosis coefficients of the data obtained from the pilot study carried out with 251 secondary school students were calculated as $-1.093 \pm .157$ and $1.223 \pm .306$. Accordingly the data showed a normal distribution.

Factor Load Analysis

The suitability of items in the draft MVAS for Factor analysis was tested by performing the sample adequacy test (Kaiser-Meyer-Olkin, KMO) and the Barlett Sphericity Test. Herein while the Barlett Test of Sphericity was found to be significant, the KMO coefficient was determined as .912 ($\chi^2=2749.526$, $df=253$, $p<0,01$). For the data set to be suitable for factor analysis, the KMO coefficient should be greater than 0.7 (Leech et al., 2005). A KMO value above .9 indicates perfect sample adequacy (Büyüköztürk, 2009). These results show that the data set is acceptable for EFA. MLE method was used as it is parallel with the Structural Equation Model (SEM) in providing EFA. The study employed Varimax for rotation and the Listwise Selection method for removing missing data. EFA showed three factors with an eigenvalue greater than 1 and all sub-factors explained 57.27% of the total variance. This value is greater than 40%, which is accepted as the minimum. However, Field (2009) reported that the significance of a factor loading depends on the sample size. Field (2009) suggested that the factor load threshold for a sample of 100 and 200 subjects should be .512 and .364, respectively. Here, the factor load threshold value was taken as .512, taking into account the standardized regression weights of the items with AMOS output. Also, Hair et. al. (2010) reported that a sample size of 100-150 people (the number of respondents) is sufficient for EFA when the factor load threshold is kept 0.6. Accordingly, the draft MVAS scale consisted of 49 items clustered under three sub-factors. In addition, the scree plot was also used in factoring the items in the draft MVAS. In the scree plot, the sharp decrease was identified to continue until the third factor. In the related component matrix chart obtained from the factor analysis, items with load values less than .6 and items with factor loads less than .1 among the items clustered under the same sub-factor were considered overlapping (Büyüköztürk, 2009). Accordingly, 27 items were removed from the 49-item draft MVAS with content validity, and a 22-item draft MVAS with a 3-factor was obtained. The lowest factor load in draft MVAS is .607 and the highest factor load is .800.. In addition, Pallant (2007) suggested that the communality value indicating the compatibility of an item in the factor with other items should not be less than .3. Accordingly, the analysis results showed that the communality values ranged between .471 and .657. In addition, the factors were named according to TAM, taking into account the expressions of the items. As a result of EFA, items 4,11,13,22,23,25,33,34,40 and 45 in PU, items 16,18,19,20,21,28 and 41 in PEU, and items 31,32,36,37,38 and 39 in UA was clustered. Finally, three factors (PU, PEU and UA) were extracted from the data as the independent variables. However, no dependent variable could be extracted from the EFA. Table 3 shows the results of EFA for the 49-item MVAS.

Table 3. Results of EFA for the 49-item MVAS

Code	Items	Factor Loading			Com*	Eigen Value	Cumulative %
		PU	PEU	UA			
PU	Item13	.801			.650	8.122	35.311
	Item34	.757			.627		
	Item22	.753			.596		
	Item11	.736			.559		
	Item33	.711			.622		
	Item23	.697			.502		
	Item25	.675			.558		
	Item4	.671			.502		
	Item40	.664			.519		

Code	Items	Factor Loading			Com*	Eigen Value	Cumulative %
		PU	PEU	UA			
	Item45	.664			.591		
PEU	Item19		.729		.548	3.366	
	Item21		.677		.622		
	Item16		.666		.657		
	Item20		.665		.521		
	Item18		.654		.474		
	Item28		.626		.653		
	Item41		.607		.591		
UA	Item36			.785	.597	1.687	57.278
	Item38			.745	.585		
	Item39			.741	.553		
	Item37			.730	.575		
	Item31			.717	.503		
	Item32			.694	.492		

Com*: Communalities; Total variance explained: 57.24 %

Herein, PU is the variable associated with the belief that the use of the metaverse will enhance learning. PEU is the variable using the effortless metaverse. UA is the variable related to positive or negative feelings towards the use of metaverse. However, unfortunately, none of the items were clustered under BI, which is the variable related to the desire to use metaverse. While cognitive and affective responses could be determined in EFA, behavioral responses could not.

Internal Consistency Analysis

Internal Consistency Analysis is an indication of the measurement status of the scale. A reliable test or scale should present similar results in the same situations. The reliability of the MVAS was determined by using the split half model, equivalent halves, and Cronbach alpha values. Spearman-Brown, Guttman split half, and Cronbach alpha reliability coefficients were examined to calculate the two-half test reliability coefficient of the scale. Table 4 shows the results of split-half reliability analyzes for MVAS

Table 4. Results of Split-half Reliability Analyses for MVAS

Confidence Coefficients (N:23)	
Correlation Between Forms = .454	Equal Length Spearman-Brown = .679
Guttman Split-Half Coefficient = .592	Unequal Length Spearman-Brown = .679
Alfa = .917 (N:11 ^a) for Part1	Alfa = .714 (N:12 ^b) for Part2
^a Items: item4, item11, item 13, item 22, item 23, item 25, item 33, item 34, item 40, item 45, item 16	
^b Items: item 19, item 20, item 21, item 28, item 31, item 32, item 37, item 38, item 39, item 41, item 36, item 18	

As in Table 4, alpha values for the first and second parts were determined to be greater than .7. These results

showed that the items was consecutive and reliable (Özdamar, 2013). Likewise, the correlation value between the forms was calculated as .454. The correlation coefficient was found to be .592 with the Guttman half split formula, and the reliability of the two halves with the Spearman-Brown formula was determined as .679. The structure similarity, collectability, and homogeneity of the items in the scale were tested with ANOVA and the results were depicted in Table 5. As observed in Table 5, the items in the scale were found to have a homogeneous structure and they were related to each other ($F=54.252, p<.001$). Besides, the scale was collectible ($F=340.259, p<.001$).

Table 5. The ANOVA Results regarding MVAS

		^b KT	df	^c OK	F	p
Between People		2584.258	250	10.337		
Within People	Between Items	1387.137	21	66.054	54.252	.000
	Residual					
	Nonadditivity	389.131 ^a	1	389.131	340.259	.000
	Balance	6002.915	5249	1.144		
	Total	6392.045	5250	1.218		
	Total	7779.182	5271	1.476		
Total		10363.439	5521	1.877		
Grand Mean = 3.3391						

^a. Tukey's estimate of power to which observations must be raised to achieve additivity = -1.584

^bKT: Sum of Squares, ^cOK: Mean squares

Özdamar (2013) questioned whether the situation that is desired to be measured with Hotelling's T-Squared analysis can be measured appropriately with the measurement tool. Accordingly, Hotelling's T-Squared Test was conducted to determine whether the test design of MVAS was appropriate. The results demonstrated that the MVAS model was in a suitable structure ($F=11,136, p<.05$). The results of Hotelling's T-Squared analysis were shown in Table 6.

Table 6. Hotelling's T-Squared Analysis Results for MVAS

Hotelling's T-Squared	F	df1	df2	Sig
254.199	11.136	21	230	.000

The ICC value is classified as follows in the relevant literature (Ridout et al, 1999):

- ✓ If the ICC value is less than .40, the in-class relationship is weak.
- ✓ If the ICC value is between .4-.59, the in-class relationship is moderate.
- ✓ If the ICC value is between .6-.74, the in-class relationship is at a good level.
- ✓ If the ICC value is greater than .74, the in-class relationship is at a very good level.

MVAS was found to be consistent in terms of individual items ($ICC=.254, p<.05$) and have a reliable construct validity in terms of mean criteria ($ICC=.882, p<.05$). It may be wise to mention that the items in the scale are valid and reliable in terms of their arrangement and structural features (Özdamar, 2013). The measurement results showed that the intraclass correlations were weak for single measures and very good for average measures. The

data including the ICC results of the MVAS was given in Table 7.

Table 7. The ICC Results of MTS

	Intraclass Correlation ^b	95% Confidence Interval		F Test with True Value 0			
		Lower Bound	Upper Bound	Value	df1	df2	Sig
Average Measurements	.882 ^c	.860	.902	8.490	250	5250	.000

Two-way mixed effects model where people effects are random and measures effects are fixed.

^aThe estimator is the same, whether the interaction effect is present or not.

^bType C intraclass correlation coefficients using a consistency definition. The between-measure variance is excluded from the denominator variance

^cThis estimate is computed assuming the interaction effect is absent because it is not estimable otherwise

Cronbach alpha value was also checked for internal consistency of MVAS. Although many techniques are used for reliability, Cronbach alpha technique is one of the most used methods in scale development processes and the determination of internal consistency (Sharma, 2016). The results regarding Cronbach alpha value are suggested in Table 8.

Table 8. Cronbach's Alpha Coefficients for MVAS and its Subdimensions

Dimension	Number of Items	Item Numbers	Cronbach Alpha
PU	10	item4, item11, item13, item22, item23, item25, item33, item34, item40, item45	.913
PEU	7	item19, item20, item21, item16, item18, item28, item41	.859
UA	6	item37, item38, item39, item31, item32	.834
		All Scale	.884

Table 8 summarizes that the Cronbach alpha values for each sub-dimension obtained as a result of the EFA analysis were quite high. The results also indicated that the internal consistency and reliability of the scale were very high. Table 8 depicts that the Cronbach alpha value for the overall scale was .884. Accordingly, it is most likely that the internal consistency of the scale is at a good level (Murphy and Davidshofer, 1988; Nunnally, 1978).

Confirmatory Factor Analysis

The data regarding the sample group participating in the pilot study were used for CFA. At first, missing data were checked for each item, and the most repeated option in that series was replaced with missing variables.

AMOS 24.0 program was used to determine the level of agreement between the three-factor structure determined as a result of the EFA and the sample data. The analysis of the data was provided by applying the likelihood model. Structural equation modeling, which is a method used in psychology, sociology, educational research, political science, marketing, etc., is a hybrid model of factor analysis and regression analysis (Dow et al., 2008). CFA examines the conformity of the estimated covariance matrix created according to the theoretical model to the covariance matrix of the observed data (Hox and Bechger, 1995). It is used when determining the construct validity of a data set and checking the hypotheses developed for the relations between variables (Tabachnick and Fidell, 2014). The fit statistics are related to the data disclosure dimension of the predetermined models. Many fit statistics test the fit of the models. These fit statistics analyze the fit of the parameters of the proposed models and the statistics obtained from the sample data. If the model does not fit the data, it is rejected. If the proposed model cannot be rejected, the model can explain the causal structure underlying the observed data (Özdamar, 2013).

First Level Confirmatory Factor Analysis

First-level confirmatory factor analysis incorporates the relationship between latent variables into the model. The path diagram of the CFA concerning the analysis of the data-model fit of the model obtained from the EFA was shown in Figure 2.

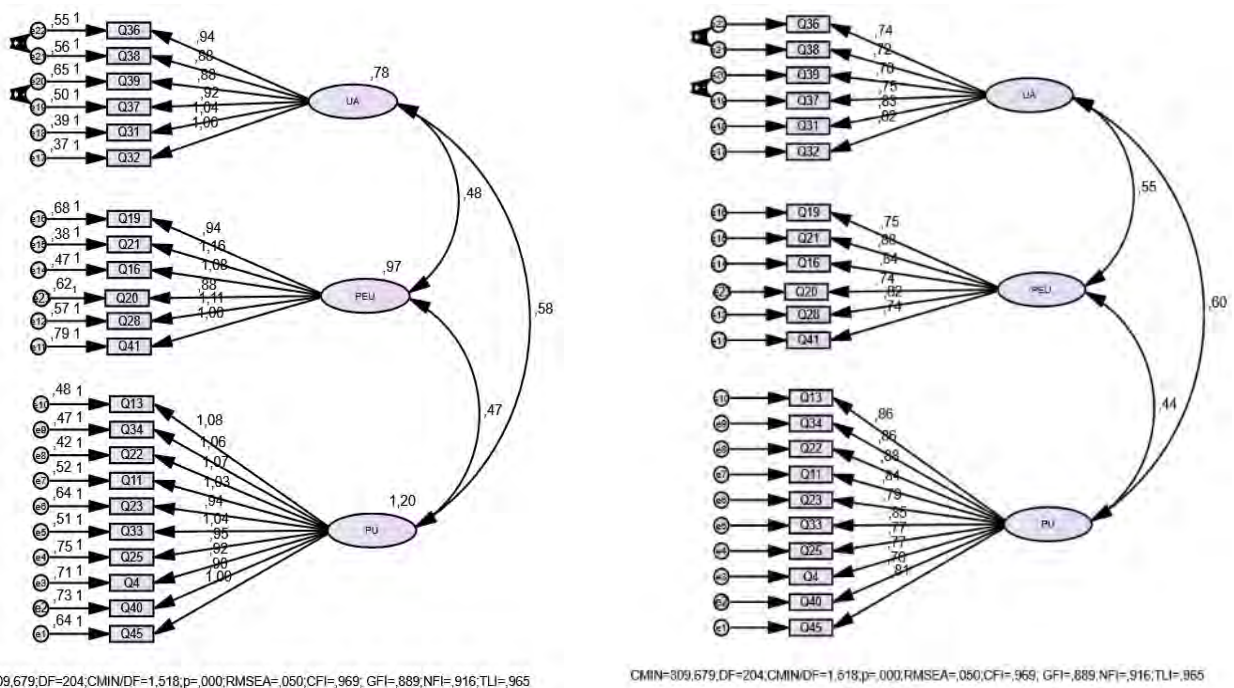

Figure 2. Unstandardized and Standardized Factor Loads in Path Diagram of MVAS

The results revealed 10 items in the PU sub-dimension, 6 items in the PEU sub-dimension, and 6 items in the UA sub-dimension. Accordingly, item 18, having low factor loading values in EFA analysis, was excluded from the MVAS. Path coefficients of the items belonging to all sub-dimensions were found to be statistically significant. Considering the standardized path coefficients, item 22 was determined to have the highest effect on PU. The item 21 had the highest effect on PEU, and the item 36 had the highest effect on UA. CFA provides information

on the level at which each item in the MVAS represents its latent variable (see Appendix B for all standardized values obtained from the first level model diagram provided with the AMOS 24.0 program using the MLE method). CFA analyses suggested that all standardized factor loadings were quite high. Accordingly, it is remarkable that the proposed model is at an excellent level and within the limits of fit. As a result of CFA, the C_{min}/df value of 22 items and the three-factor scale was found to be 1.712 (C_{min} : 309 df:204, $p < .05$). According to Kline (2011) the proposed model is excellent if the C_{min}/df value is below 2. if the C_{min}/df value is below 5, the model is at an acceptable level. In addition, other goodness-of-fit indices such as Normed Fit Index ($NFI \geq .95$, good; Bentler and Bonett, 1980), Comparative Fit Index ($CFI \geq .97$, good; Hooper et al. 2008), Goodness of Fit Index ($GFI \geq .90$, acceptable; Schermelleh and Moosbrugger, 2003), Adjusted Goodness of Fit Index ($AGFI \geq .90$, good; Schermelleh and Moosbrugger, 2003), Relative Fit Index ($RFI \geq .90$, good; Schermelleh and Moosbrugger, 2003), Root Mean Square Error of Approximation ($RMSEA \leq .005$, good; Hooper et al., 2008), Standardized Root Mean Square Residual ($SRMR \leq .005$, good; Schermelleh and Moosbrugger, 2003) were also examined to determine the degree of fit between model and data. Accordingly, RMSEA, SRMR, GFI, AGFI, NFI, CFI and RFI values for model-data fit were determined as .05, .049, .889, .871, .9146, .965, .916, respectively. These values supported the proposed three-factor model theoretically and statistically. Accordingly, the results revealed that the model and data had a good fit.

Convergent and Discriminant Validity

As regards the TAM, which was created for the research, a first-level confirmatory analysis was carried out to reveal the interrelationships across the variables. Thus, the correlation values between the UA, PU, and PEU variables were found to be acceptable and significant (see Table 9). Convergent and discriminant validity was carried out to determine whether the observed variables were a part of the latent structures (Fornell and Larcker, 1981). Convergent validity indicates whether the observed variables measure the latent variable, while convergent validity determines the relationship between the observed variables and the latent variable (Hair et al., 2010). Convergent validity requires $CR > .70$, $AVE > .50$, and $CR > AVE$. $MSV < AVE$ and $ASV < AVE$ are required to ensure discriminant validity. Besides, the square root of the AVE value should be greater than the correlation value between the variables (Hu and Bentler, 1999).

Table 9. Composite Reliability and Explained Mean-variance Values of the Variables

	CR	AVE	MSV	ASV	MaxR (H)	UA	PU	PEU	Cronbach's Alpha
UA	.953	.670	.379	.3493	.956	.818 ^a			.953
PU	.889	.675	.319	.2564	.920	.600	.821 ^a		.911
PEU	.924	.634	.379	.2865	.910	.550	.440	.796 ^a	.898

CR: Composite reliability, AVE: Average shared variance, MSV: Maximum shared variance, ASV: Average shared variance, Note: Diagonal values (a) are the square roots of AVE values

On analyzing Table 9, the lowest value of the calculated AVE for latent variables was noted as .634 and the lowest calculated CR value as .889, meaning that convergent validity was provided for all latent variables in the measurement model. With regard to the square roots of AVE values and correlations between variables,

discriminant validity was ensured for all latent variables. The results showed that the MSV and ASV values are smaller than the AVE value and the values are sufficient and acceptable.

Testing the Structural Model

This study aims at revealing the relations between the variables through examining the reflections of secondary school students' attitudes towards the use of metaverse as a learning environment within the scope of TAM. At that point, the relationships among the variables were tested through structural modeling after verification with the first level CFA. Besides, the relationship between structures in model was evaluated. In other words, the effect of PEU on PU and UA, and the effect of PU on UA were investigated. This is the basis for the TAM model. Path analysis with observed variables was deployed to test the mutual effects in the analysis. Figure 3 shows the non-standardized and standardized path diagram of the metaverse scale.

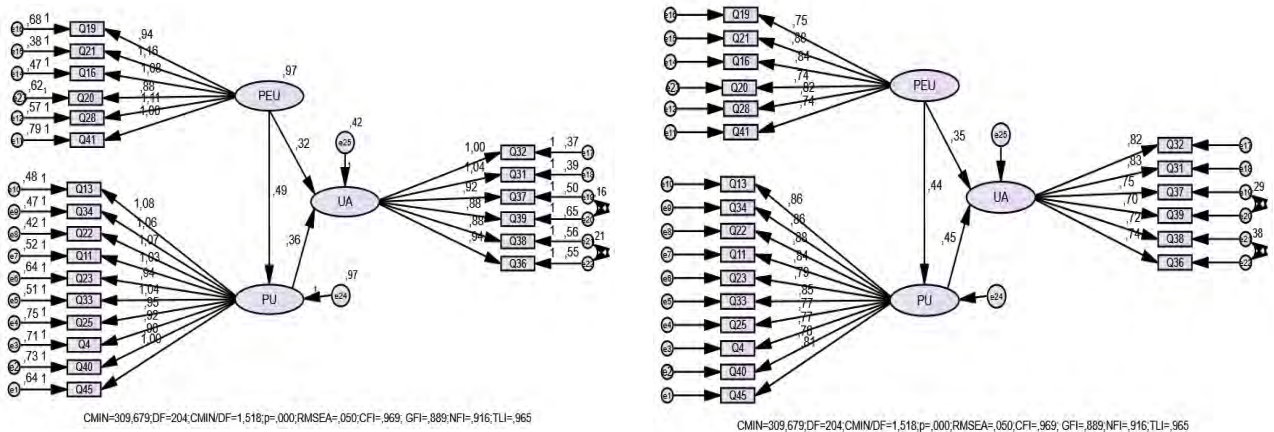

Figure 3. Non-standardized and Standardized Path Diagram of MVAS

The results of SEM analysis displayed that RMSEA, SRMR, GFI, AGFI, NFI, CFI and NFI values were determined to be .050, .049, .889, .862, .916, .969, .915, respectively. These values verified the accuracy of the proposed three-factor model. The results also revealed that the model and the data in the model have a good fit (see Appendix C for parameter estimates of the analysis). Here, the results showed that the constructed structural model was compatible and the model fit indexes remained within the specified limits, and all standardized and non-standardized path coefficients were positive and significant.

Testing the Hypotheses

The research model and hypotheses were tested through studies of construct validity. The obtained data revealed the accuracy of the research model. Cognitive and affective variables regarding motivation were extracted from EFA. However, the variable of intention to use regarding the behavioral field could not be extracted from the EFA. Therefore, the H3 hypothesis could not be tested in the research model. On the other hand, the H1, H2 and H3 hypotheses were welcomed as the path coefficients had a positive and significant value.

Conclusions

This study is an attempt to develop a valid and reliable metaverse scale for secondary school students. The content and construct validity of the MVAS were examined during the scale development process. The content validity of the MVAS was initially carried out with 6 steps specified by Polit and Beck (2006). These successive steps were implemented as follows.

- ✓ Preparing the content verification form,
- ✓ Selecting a review panel with expert staff,
- ✓ Performing content verification,
- ✓ Examining the area and items,
- ✓ Calculating scores for each item,
- ✓ Finding I-CVI and S-CVI values.

The calculations were completed in line with the reports of Ayre and Scally (2014) for the CVR value and Lynn (1986) and Polit and Beck (2006) for the CVI values. A 54-item draft form was created after the literature review and panel discussions were completed to develop a scale suitable for secondary school students. 14 experts' views were received in line with the scaling-scoring suggestion of Yusoff (2019). As a result of the scoring, five items with kappa values below .48 were removed from the test. The CVI/Ave and S-CVI/UA values of the remaining 49-item draft MVAS were calculated to be .93, and .84, respectively. Following content validity, face validity was performed to examine the simplicity of the language of the form and the clarity of the structure (Yusoff, 2019). The 49-item draft form was presented to a panel group of 30 secondary school students. All calculations and determinations of face validity were performed with the recommendations of Ozair et al. (2017). I-FVI, S-FVI, S-FVI/Ave, and S-FVI/UA values were obtained as .91, .91, .93, and .83, respectively. There was no item eliminated as a result of face validity. Secondly, EFA and CFA were used for construct validity. The present study confirmed whether the data demonstrated normal distribution through using the skewness and kurtosis statistics. The skewness and kurtosis coefficient was calculated as $1.093 \pm .157$ and $1.223 \pm .306$, respectively. The suitability of the draft MVAS for factor analysis was analyzed by performing the KMO sample adequacy test and the Barlett Sphericity test. The Barlett Test of Sphericity ($\chi^2=2749.526$, $df=253$, $p<0,01$) was significant and the KMO coefficient was determined as .912. This result showed that the data set is acceptable for EFA. In EFA, the data set was found to have three factors according to the TAM model. Three factors with an eigenvalue greater than 1 explained 52.27% of the total variance of all sub-factors. The analysis results indicated that 26 items were removed from the draft MVAS. Thus, 49 items in the draft MVAS were reduced to 23 items. In addition, the scree plot was also used in factoring the items in the MVAS. A sharp decrease in the scree plot was determined to continue until the third factor. In the internal consistency analysis of MVAS, the reliability of the scale was determined by using the Split Half model and using Cronbach alpha values. Cronbach alpha values were calculated as .917 for the first half and .714 for the second half. These results show that the items are consecutive and reliable (Özdamar, 2013). Similarly, the correlation value between the forms was calculated as .454. Besides, the correlation coefficient with the Guttman half split formula was found as .592. In addition, the reliability of the two halves with the Spearman-Brown formula was determined to be .679. In addition, ANOVA Tukey's Nonadditivity analysis was carried out to determine their relationship with each other and the homogeneity of the items in MVAS. As a result, the items in MVAS were found to be homogeneous ($F=54.252$, $p<0.001$) and the test were collectible ($F=340.259$, $p<.001$).

On the other hand, Hotelling's T-Squared analysis showed that MVAS consisted of homogeneous, strong, and unique items ($F=11.136$, $p<.05$) and was effective in measuring. Each item of the MVAS was individually consistent ($ICC=0.254$, $p<.05$) and had a reliable structure in terms of mean criteria ($ICC=0.882$, $p<.05$) (Ridout et al, 1999). The internal consistency of MVAS was extremely high in terms of single and average measurements. Finally, the Cronbach alpha value for the overall MVAS was found to be 0.884.

The AMOS 24.0 program was used to determine the level of agreement between the three-factor structure. The fit indices for model-data fit were determined as .05 for RMSEA, .049 for SRMR, .889 for GFI, .871 for AGFI, .9146 for NFI, .965 for CFI and .916 for RFI. These values supported the proposed three-factor model theoretically and statistically. Accordingly, the results revealed that the model and the data in the model had a good fit. As a result of the analysis, an item in the EFA was excluded from the structure. It was found to be 6 items under the UA sub-dimension, 10 items under the PU sub-dimension, and 6 items under the PEU sub-dimension. Upon analyzing the standardized path coefficients, the items with the highest effect on UA, PEU, and PU were item31, item24, and item34, respectively. The AVE, MSV, and ASV values calculated for the latent variables provided validity in convergent and discriminant validity. The relationship between the model and the structures was provided by the second-level confirmatory factor analysis. As a result of SEM analysis, RMSEA, SRMR, GFI, AGFI, NFI, CFI, NFI values were found as .050, .049, .889, .862, .916, .969, and .915, respectively. These values verified the accuracy of the proposed three-factor model. All standardized and non-standardized path coefficients were positive and significant.

Herein this study aims at measuring the adoption and using levels of the metaverse of secondary school students. There is a dearth of studies conducted on the adoption of metaverse studies. Besides, there is no such a study specifically published on investigating metaverse in terms of TAM. Hence, this study can be a reference source for further studies. The results pinpointed that the most significant factors affecting the adoption and use of metaverse by secondary school students were perceived ease of use and perceived usefulness related to the application. The results also highlighted that the hypotheses determined by the research model were accepted. Namely, ease of use influenced the perceived usefulness of the metaverse. In addition, perceived ease of use and perceived usefulness of metaverse had a positive effect on the intention to use. Although secondary school students reacted positively to cognitive responses (perceived ease of use, perceived usefulness of use) and affective responses (user attitude) about the metaverse, they could not transform these responses into behavioral responses (behavioral intention). This may be due to the technological inadequacies, the need for expert experience of many metaverse programs, and new technology. On the other hand, the difference in behavior of individuals can be observed depending on the strength of the attitude. Namely, the presence of attitude sometimes may not be enough to observe the behavior. In such cases, attitude may influence behavior only when the individual interacts with the environment (Atkinson et al, 1995). The students did not spend much time in the meta-universe and thus, the attitude did not affect the behavior. However, the TAM model revealed that secondary school students had absolute motivation for the use of metaverse. In this context, Suh and Ahn (2022) stated that the use of metaverse for educational purposes had a positive effect on most students. Guo and Gao (2022) suggested that the metaverse could improve students' learning activities and improve students' cognitive feelings of interaction in teaching English. On the other hand, Kye et al. (2021) defined metaverse as a new educational

environment. Lee et al. (2022) designed a scale for distance education with Metaverse based on aircraft maintenance simulation and emphasized that the system they proposed had an effect on learning in the field of technical education such as aircraft maintenance. Talan and Kalınkara (2022) examined the computer engineering students' views towards Metaverse. They concluded that the students had not used Metaverse before, but they were eager to use it in their lessons. Reyes (2020) examined high school students' perceptions towards the use of Metaverse in mathematics lessons. Accordingly the use of virtual reality in the classroom increased the perception of changes in learning.

Recommendations

Based on the research findings, following recommendations were provided:

- ✓ MVAS scale addresses all grade levels of secondary education. There is no need to develop a separate scale for each grade level. Therefore, it can be used as an important assessment tool in various metaverse applications at the secondary education level.
- ✓ MVAS scale can be used as a data collection tool to examine students' attitudes in experimental studies and the effect of metaverse on the secondary school level.
- ✓ Students' behavioral reactions should be evaluated to popularize the use of metaverse at the secondary school level. Technological infrastructures should be developed for this.
- ✓ Similar studies may examine how teachers and students understand the metaverse. Teachers should design classrooms that allow students to solve problems or collaborate. Educational metaverse platforms should be developed to prevent students from misusing data.

References

- Adams, D., Nelson, R., & Todd, P. (1992). Perceived usefulness, ease of use, and usage of information technology: A replication. *MIS quarterly*, 227-247.
- Altunışık, R., Coşkun, R., Bayraktaroğlu, S., & Yıldırım, E. (2012). *Research methods in social sciences: SPSS Applied* (7th Edition). Istanbul: Avcı Ofset.
- Atkinson, R., Atkinson, R. C. and Hilgard, E. R. (1995). *Introduction to psychology* (14th Edition). New York: Harcourt.
- Aydın, C. (2002). Past and present of educational environments. *Kurgu Anadolu University Faculty of Communication Sciences International Refereed Journal of Communication*, 19(19), 151-161.
- Ayre, C., & Scally A. J. (2014). Critical values for Lawshe's content validity ratio: revisiting the original methods of calculation. *Measurement and Evaluation in Counseling and Development*, 79-86.
- Bagozzi, R., & Yi, Y. (1988). On the evaluation of structural equation models. *Journal of the Academy of Marketing Science*, 16, 74-94.
- Barry, D., Ogawa, N., Dharmawansa, A., Kanematsu, H., Fukumura, Y., Shirai, T., . . . Kobayashi, T. (2015). Evaluation for students' learning manner using eye blinking system in metaverse. *Knowledge-Based And Intelligent Information & Engineering Systems 19th Annual Conference* (pp. 1195-1204, DOI: 10.1016/j.procs.2015.08.181). Kes-2015.

- Batdı, V., & Talan, T. (2019). Augmented reality applications: A Meta-analysis and thematic analysis. *Turkish Journal of Education*, 8(4), 276-297. doi:http://dx.doi.org/10.19128/turje.581424
- Bentler, P., & Bonett, D. (1980). Significance tests and goodness of fit in analysis of covariance structures. *Psychological Bulletin*, 88(3), 588-606.
- Boudreau, M., Gefen, D., & Straub, D. (2001). Validation in information systems research: A state-of-the-art assessment. *MIS quarterly*, 1-16.
- Buyukozturk, S. (2009). *Handbook of data analysis for social sciences. (10th ed.)*. Ankara: Pegem.
- Büyüköztürk, Ş. (2007). *Manual of data analysis for social sciences*. Ankara: Pegem A Publishing.
- Choi, H. (2022). Working in the metaverse: Does telework in a metaverse office have the potential to reduce population pressure in megacities? Evidence from young adults in seoul south Korea. *Sustainability*, 14(6), DOI: 10.3390/su14063629.
- Creswell, J. (2014). *Research design: Qualitative, quantitative, and mixed methods approaches (4th ed.)*. CA:Sage: Thousand Oaks.
- Davis, F. (1989). Perceived usefulness, perceived ease of use, and user acceptance of information technology. *MIS Q.*, 13, 319.
- Demirli, C. (2002). The effect of Web based teaching on students achievement in instructional technologies and material development course (The sample Technical Education Faculty of FU). (*Thesis of Doctoral*), 122047.
- Diaz, J. (2020). Virtual world as a complement to hybrid and mobile learning. *International Journal of Emerging Technologies In Learning* 15(22), 267-274 DOI: 10.3991/ijet.v15i22.14393.
- Dow, K., Jackson, C., Wong, J., & Leitch, R. (2008). A Comparison of structural equation modeling approaches: The Case of User Acceptance of Information Systems. *Journal of Computer Information Systems (Summer)*.
- Durak, G., Çankaya, S., & İzmirli, S. (2020). Investigation of distance education systems of universities in Turkey during the COVID-19 pandemic period. *Necatibey Faculty of Education elektronik journal of Science and mathematics education*, 14(1), 787-809.
- Field, A. P. (Discovering statistics using SPSS). 2009. London: England Sage.
- Fishbein, M. (1966). *The Relationships between beliefs, attitudes and behavior*. In S. Feldman (ed), Cognitive Consistency. New York: Academic Press
- Fleiss, J. L. (1971). Measuring nominal scale agreement among many raters. *Psychological bulletin*, 378.
- Fornell, C., & Larcker, D. (1981). Evaluating structural equation models with unobservable variables and measurement error. *Journal of Marketing Research*, 18(1), 39–50.
- Gartner. (2022). *Predicts 2022: 4 Technology bets for building the digital future*. Retrieved January 12, 2023, from <https://www.businesswire.com/news/home/20220207005085/en>.
- George, D., & Mallery, M. (2010). *SPSS for Windows step by step: A Simple guide and reference, 17.0 update (10a ed.)*. Boston: Pearson.
- Gomes, A., & Klein, A. (2013). The Development of distance teamwork competence through the use of the second life (R) Metaverse. *Administracao-Ensino e Pesquisa*, 14 (2), 343-375 DOI: 10.13058/raep.2013.v14n2.68.
- Gökçe, A. (2008). Distance education in the process of globalization. *Journal of Dicle University Ziya Gökalp*

- Faculty of Education, (11)*, 1-12.
- Guo, F., & Liu, F. (2013). A study on the factors influencing teachers' behaviour of internet teaching research. *Int. J. Contin. Eng. Educ. Life-Long Learn.*, 23, 267-281.
- Guo, H., & Gao, W. (2022). Metaverse-powered experiential situational english-teaching design: An emotion-based analysis method. *Frontiers In Psychology*, DOI: 10.3389/fpsyg.2022.859159.
- Hair, J.F., Black, W.C., Babin, B.J., & Anderson, R. (2010). *Multivariate data analysis*. Prentice Hall. Upper Saddle River, NJ
- Hooper, D., Coughlan, J., & Mullen, M. (2008). Structural equation modelling: Guidelines for determining model fit. *The Electronic Journal of Business Research Methods*, 6(1), 53-60.
- Hox, J., & Bechger, T. (1995). An Introduction to structural equation modeling. *Family Science Review*, 11.
- Hu, L.-T., & Bentler, P. (1999). Cut off criteria for fit indexes in covariance structure analysis: Conventional criteria versus new alternatives. *Structural Equation Modeling: A Multidisciplinary Journal*, 6(1), 1-55.
- Huh, S. (2022). Application of computer-based testing in the Korean Medical Licensing Examination, the emergence of the metaverse in medical education, journal metrics and statistics, and appreciation to reviewers and volunteers. *Journal of Educational Evaluation For Health Professions*, DOI: 10.3352/jeehp.2022.19.2.
- Ibrahim, A., & Shiring, E. (2022). The Relationship between educators' attitudes, perceived usefulness, and perceived ease of use of instructional and web-based technologies: Implications from Technology Acceptance Model (TAM). *International Journal of Technology in Education (IJTE)*, 5(4), 535-551. doi:https://doi.org/10.46328/ijte.285
- Idris, F., Hassan, Z., Ya'acob, A., Gill, S., & Awal, N. (2012). The role of education in shaping youth's national identity" *Procedia - Social and Behavioral Sciences*, 443-450.
- Jaramillo-Mujica, J., Morales-Avella, L., & Coy-Mondragon, D. (2017). An experience using metaverses for teaching mechanical physics to engineering students. *Revista Educacion En Ingenieria 12(24)*, 20-30 DOI: 10.26507/rei.v12n24.778.
- Jondeau, E., & Rockinger, M. (2003). Conditional volatility, skewness, and kurtosis: existence, persistence, and comovements. *Journal of Economic Dynamics & Control*, 27, 1699-1737.
- Jondeau, E., & Rockinger, M. (2003). Conditional volatility, skewness, and kurtosis: existence, persistence, and comovements. *Journal of Economic dynamics and Control*, 27(10), 1699-1737.
- Jovanovic, A., & Milosavljevic, A. (2022). VoRtex metaverse platform for gamified collaborative learning. *Electronics*, 11 (3), DOI: 10.3390/electronics11030317.
- K., Ö. (2016). *Scale and test development in education, Health and behavioral sciences structural equation modeling IBM SPSS, IBM SPSS AMOS and MINITAB applied*. Eskişehir: Nisan Bookstore.
- Kalaycı, N. (2010). An analysis of project-based learning in higher education in terms of students who manage the project. *Education and Science*, 33(147), 85-105.
- Kamenov, K. (2022, May 20). *Immersive experience—The 4th wave in tech: Learning the ropes*. retrieved from <https://www.accenture.com/gb-en/blogs/blogs-immersive-experience-wave-learning-ropes>
- Kanematsu, H., Kobayashi, T., Barry, D., Fukumura, Y., Dharmawansa, A., & Ogawa, N. (2014). Virtual STEM class for nuclear safety education in metaverse. *Proc. Comput. Sci.*, 35, 1255-1261.
- Kline, R. B. (2011). *Principles and practice of structural equation modeling (3rd ed.)*. New York London: The

Guilford Press.

- Kye, B., Han, N., Kim, E., Park, Y., & Jo, S. (2021). Educational applications of metaverse: possibilities and limitations. *Journal Of Educational Evaluation For Health Professions*, 1-13 DOI: 10.3352/jeehp.2021.18.32.
- Landry, B., Griffeth, R., & Hartman, S. (2006). Measuring student perceptions of blackboard using the technology acceptance model. *Decision Sciences Journal of Innovative Education*, 4(1), 87-99.
- Lawshe, C. H. (1975). A quantitative approach to content validity. *Personnel psychology*, 536-575.
- Lee, H., & Hwang, Y. (2022). Technology-enhanced education through VR-making and metaverse-linking to foster teacher readiness and sustainable learning. *Sustainability*, 14(8), DOI: 10.3390/su14084786.
- Leech, N., Barrett, K., & Morgan, G. (2005). *SPSS for Intermediate statistics, use and interpretation. (2nd ed.)*. Mahwah: Lawrence Erlbaum Associates Inc.
- Locurcio, L. (2022). Dental education in the metaverse. *British Dental Journal* 232(4), 191 DOI: 10.1038/s41415-022-3990-7.
- Lynn, M. R. (1986). Determination and quantification of content validity. *Nursing research*.
- Mathieson, K. (1991). Predicting user intentions: comparing the technology acceptance model with the theory of planned behavior. *Inf. Syst. Res.* 2, 173–191. <http://dx.doi.org/10.2307/23010882>.
- Miller, C. (1996). A historical review of applied and theoretical spatial visualization publications in engineering graphics. *The Engineering Design Graphics Journal*, 60(3), 12-33.
- Moon, J., & Kim, Y. (2001). Extending the TAM for a World-Wide-Web context. *Inf. Manag.*, 38, 217-230.
- Murphy, K., & Davidshofer, C. (1998). *Psychological testing: Principles and applications (4th edn.)*. New Jersey: Prentice-Hall.
- Mystakidis, S. (2022). Metaverse. *Encyclopedia*, 2(1), 486-497.
- N., B. (2013). *Introduction to structural equation modeling*. Ankara: Ezgi Bookstore Publishing.
- Nitko, A. (1996). *Educational assessment of students (211 d ed.)*. Englewood: Cliffs:Prentice hall.
- Nunnally, J. (1978). *Psychometric Theory*. New York: McGraw-Hill.
- Orland, K. (2022, May 20). *Ars Technica*. Retrieved from wired: <https://www.wired.com/story/what-is-the-metaverse/#:~:text=Broadly%20speaking%2C%20the%20technologies%20companies,the%20digital%20and%20physical%20worlds>.
- Orts-Cortés, M. I., Moreno-Casbas, T., Squires, A., Fuentelsaz-Gallego, C., Maciá-Soler, L., & González-María, E. (2013). Content validity of the Spanish version of the practice environment scale of the nursing work index. *Applied Nursing Research*, 5-9.
- Ozair, M., Baharuddin, K., Mohamed, S., Esa, W., & Yusoff, M. (2017). Development and validation of the knowledge and clinical reasoning of acute asthma management in emergency department (K-CRAMED). *Education in Medicine Journal*, 9(2), 1-17.
- Özdamar, K. (2010). *Biostatistics with PASW*. Eskişehir: Kaan Bookstore.
- Özdamar, K. (2013). *Statistical data analysis with package programs-II, (Multivariate Methods), 9th Edition*. Eskişehir: Nisan Bookstore.
- Özmen, A. (2000). *Sampling methods in applied research*. Eskişehir: Anadolu University Publishing.
- Pallant, J. (2007). *SPSS survival manual: A step by step guide to data analysis using SPSS for Windows (3rd ed.)*. Berkshire: Open University Press.

- Park, S., & Kim, S. (2022). Identifying world types to deliver gameful experiences for sustainable learning in the Metaverse. *Sustainability*, 14(3), 1361 DOI:10.3390/su14031361.
- Park, S., & Kim, Y. (2022). A Metaverse: Taxonomy, components, applications, and open challenges. *IEEE ACCESS* 10, 4209-425 DOI:10.1109/ACCESS.2021.3140175.
- Polit, D. F., & Beck, C. T. (2006). The content validity index: are you sure you know what's being reported? Critique and recommendations. *Research in nursing & health*, 489-497.
- Reyes, C. (2020). Perception of high school students about using Metaverse in augmented reality learning experiences in mathematics. *Pixel-Bit- Revista De Medios Y Educacion*, 143-159, DOI: 10.12795/pixelbit.74367.
- Ridout, M., Demetrio, C., & Firth, D. (1999). Estimating intraclass correlation for binary data. *Biometrics*, 55 (1), 137-148.
- S., B. (2010). Professional problems encountered by social workers in working life: The case of Bursa. *Journal of Society and Social Work*, 21(1), 99-109.
- Saritas, M., & Topraklikoglu, K. (2022). Systematic literature review on the use of metaverse in education. *International Journal of Technology in Education (IJTE)*, 5(4), 586-607. doi:https://doi.org/10.46328/ijte.319
- Schermelleh, E., & Moosbrugger, H. (2003). Evaluating the fit of structural equation models: Tests of significance and descriptive goodness-of-fit measures. *Methods of Psychological Research Online*, 8.
- Sharma, B. (2016). A focus on reliability in developmental research through Cronbach's Alpha among medical, dental and paramedical professionals. *Asian Pacific Journal of Health Sciences*, 3, 271-278. Doi: 10.21276/apjhs.2016.3.4.43.
- Shi, J., Mo, X., & Sun, Z. (2012). Content validity index in scale development. *Zhong nan da xue xue bao. Journal of Central South University. Medical Sciences*, 152-155.
- Stephenson, N. (1992). *Snow Crash (2011th edt.)*. London: Penguin.
- Suh, W., & Ahn, S. (2022). Utilizing the metaverse for learner-centered constructivist education in the post-pandemic era: An Analysis of elementary school students. *Journal of Intelligence* 10 (1), DOI: 10.3390/jintelligence10010017.
- Sun, H., & Zhang, P. (2006). Causal relationships between perceived enjoyment and perceived ease of use: An alternative approach. *Journal of the Association for Information Systems*, 7(1), 24.
- Tabachnick, B., & Fidell, L. (2014). *Using multivariate statistics (New International Ed.)*. Harlow: Pearson.
- Talan, T., & Kalinkara, Y. (2022). Students' opinions about the educational use of the metaverse. *International Journal of Technology in Education and Science (IJTES)*, 6(2), 333-346. doi:https://doi.org/10.46328/ijtes.385
- Tas, N., & Bolat, Y. (2022). Bibliometric mapping of metaverse in education. *International Journal of Technology in Education (IJTE)*, 5(3), 440-458. doi:https://doi.org/10.46328/ijte.323
- Tekin, H. (1977). *Quantitation and evaluation in education*. Ankara: Mars Publishing.
- Venkatesh, V. & Davis, F.D. (2000). A Theoretical extension of the Technology Acceptance Model: Four longitudinal field studies. *Institute for Operations Research and the Management Sciences*, 46, pp. 186–204.
- Wynd, C. A., Schmidt, B., & Schaefer, M. A. (2003). Two quantitative approaches for estimating content validity.

Western journal of nursing research, 508-518.

Yamane, T. (1967). *Statistics, An Introductory Analysis, 2nd Ed.* New York: Harper Row.

Yeşilyurt, S., & Çapraz, C. (2018). A roadmap for content validity used in scale development studies. *Journal of Erzincan University Faculty of Education*, 20(1), 251-264.

Yıldırım, I. (2020). The effect of augmented reality applications in science teaching on the academic achievement and retention of 6th grade students. *Master Thesis*. Turkey: Institute of Educational Sciences, Eskişehir. Retrieved January 13, 2023, from <https://tez.yok.gov.tr/UlusalTezMerkezi/>

Yong, A., & Pearce, S. (2013). A beginner's guide to factor analysis: Focusing on exploratory factor analysis. *Tutorials in Quantitative Methods for Psychology*, 9(2), 79-94. DOI: 10.20982/tqmp.09.2.p79.

Yusoff, M. S. B. (2019). ABC of content validation and content validity index calculation. *Education in Medicine Journal*. 11(2), 49-54.

Zhang, X., Chen, Y., Hu, L., & Wang, Y. (2022). The metaverse in education: Definition, framework, features, potential applications, challenges, and future research topics. *Frontiers in Psychology* 13. doi:10.3389/fpsyg.2022.1016300

Author Information

Ömer Kırbaş

 <https://orcid.org/0000-0003-2670-7365>

(Corresponding Author)

Ministry of National Education

Kocaeli,

Turkey

Contact e-mail: omerkirbas16@gmail.com

Fatih Doğan

 <https://orcid.org/0000-0001-5844-8893>

Çanakkale Onsekiz Mart University

Faculty of Education, 17100-Çanakkale

Turkey

Appendix A. Expert System for the Content Validity of Draft MVAS

Items	Expert														Score				NA	I-CVI	UA	CVR	pcxl0 ³	k [*]	Rating ^a
	E1	E2	E3	E4	E5	E6	E7	E8	E9	E10	E11	E12	E13	E14	4	3	2	1							
Item1	4	4	4	4	3	4	4	4	4	4	4	4	4	4	13	1		14	1.00	1	1.00	.061	1.00	excellent	
Item2	4	4	4	4	4	4	4	4	4	4	4	3	4	4	4	13	1	14	1.00	1	1.00	.061	1.00	excellent	
Item3	4	4	4	4	4	4	3	4	4	4	4	4	4	4	13	1	14	1.00	1	1.00	.061	1.00	excellent		
Item4	4	4	3	4	4	4	4	4	4	4	4	4	4	4	13	1	14	1.00	1	1.00	.061	1.00	excellent		
Item5	4	4	4	4	4	4	4	4	3	4	4	4	4	4	13	1	14	1.00	1	1.00	.061	1.00	excellent		
Item6	4	4	4	4	4	4	4	3	4	4	4	4	2	4	12	1	1	13	0.93	0	0.86	.85	0.93	excellent	
Item7	3	2	4	2	2	3	4	3	4	3	2	2	2	2	3	4	7	7	0.50	0	0.00	209	0.37	poor	
Item8	4	4	4	4	4	4	3	2	4	4	4	4	4	4	12	1	1	13	0.93	0	0.86	.85	0.93	excellent	
Item9	4	3	4	4	4	4	4	4	3	4	4	4	4	4	12	2	14	1.00	1	1.00	.061	1.00	excellent		
Item10	4	4	4	4	4	4	4	3	4	4	4	4	2	4	12	1	1	13	0.93	0	0.86	.85	0.93	excellent	
Item11	2	4	4	4	4	4	4	4	3	4	4	4	4	4	12	1	1	13	0.93	0	0.86	.85	0.93	excellent	
Item12	4	4	4	4	4	4	4	4	4	4	4	4	4	3	13	1	14	1.00	1	1.00	.061	1.00	excellent		
Item13	4	4	4	4	4	4	4	3	4	4	4	4	4	4	13	1	14	1.00	1	1.00	.061	1.00	excellent		
Item14	4	4	4	4	4	3	4	4	4	4	4	4	4	4	13	1	14	1.00	1	1.00	.061	1.00	excellent		
Item15	4	4	4	4	3	4	4	4	4	4	4	4	4	4	13	1	14	1.00	1	1.00	.061	1.00	excellent		
Item16	3	4	4	4	4	4	4	4	4	4	4	4	4	4	13	1	14	1.00	1	1.00	.061	1.00	excellent		
Item17	4	4	4	4	4	4	4	4	4	4	4	4	4	3	13	1	14	1.00	1	1.00	.061	1.00	excellent		
Item18	2	2	2	3	2	3	4	4	3	2	2	2	2	3	3	4	7	7	0.50	0	0.00	209	0.37	poor	
Item19	4	4	4	4	4	4	4	4	3	4	4	4	4	4	13	1	14	1.00	1	1.00	.061	1.00	excellent		
Item20	4	3	4	4	4	4	4	4	4	4	3	4	4	4	12	2	14	1.00	1	1.00	.061	1.00	excellent		
Item21	4	4	4	4	4	4	4	3	4	4	4	3	4	4	12	2	14	1.00	1	1.00	.061	1.00	excellent		
Item22	4	4	3	4	4	3	4	4	2	4	4	4	4	4	11	2	1	13	0.93	0	0.86	.85	0.93	excellent	
Item23	4	3	4	4	4	4	4	4	4	4	4	4	4	4	13	1	14	1.00	1	1.00	.061	1.00	excellent		
Item24	2	2	2	3	2	3	4	4	3	2	2	2	4	2	3	3	4	7	7	0.50	0	0.00	209	0.37	poor
Item25	4	3	4	4	4	4	4	4	4	4	4	4	4	4	13	1	14	1.00	1	1.00	.061	1.00	excellent		
Item26	4	4	3	4	4	4	4	4	4	3	4	4	4	4	13	1	14	1.00	1	1.00	.061	1.00	excellent		
Item27	4	4	4	2	4	4	4	4	4	4	2	4	3	11	1	2	12	0.86	0	0.71	5.55	0.86	excellent		
Item28	4	4	4	4	3	4	4	4	4	4	4	4	4	4	13	1	14	1.00	1	1.00	.061	1.00	excellent		
Item29	4	4	4	4	4	4	3	4	4	4	4	4	4	4	13	1	14	1.00	1	1.00	.061	1.00	excellent		
Item30	4	4	4	4	4	4	4	4	4	4	4	3	3	4	12	2	14	1.00	1	1.00	.061	1.00	excellent		
Item31	4	4	4	4	4	3	4	4	4	3	4	4	4	4	12	2	14	1.00	1	1.00	.061	1.00	excellent		
Item32	2	4	2	2	3	4	4	4	4	2	2	2	4	4	7	1	6	8	0.57	0	0.14	18.2	0.48	poor	
Item33	4	4	3	4	4	4	4	4	4	4	4	4	4	3	12	2	14	1.00	1	1.00	.061	1.00	excellent		
Item34	4	3	4	4	4	4	4	4	4	3	4	3	4	4	11	3	14	1.00	1	1.00	.061	1.00	excellent		
Item35	4	4	3	4	4	4	4	4	4	4	4	4	4	4	13	1	14	1.00	1	1.00	.061	1.00	excellent		
Item36	4	4	4	4	3	2	4	4	4	4	4	3	4	4	11	2	1	13	0.93	0	0.86	.85	0.93	excellent	
Item37	4	4	3	4	4	4	3	4	4	4	4	4	4	4	12	2	14	1.00	1	1.00	.061	1.00	excellent		
Item38	4	4	4	4	3	4	4	4	4	4	4	4	3	12	2	14	1.00	1	1.00	.061	1.00	excellent			
Item39	4	4	4	3	4	4	4	4	4	4	4	4	4	4	13	1	14	1.00	1	1.00	.061	1.00	excellent		
Item40	4	4	4	4	3	4	4	4	4	4	3	4	4	4	12	2	14	1.00	1	1.00	.061	1.00	excellent		
Item41	4	3	2	4	4	4	4	2	4	2	4	4	4	3	9	2	3	11	0.79	0	0.57	2.22	0.78	excellent	
Item42	4	4	4	4	3	4	4	4	4	4	4	3	4	4	12	2	14	1.00	1	1.00	.061	1.00	excellent		
Item43	4	4	4	4	3	4	4	4	4	4	3	4	4	4	12	2	14	1.00	1	1.00	.061	1.00	excellent		
Item44	4	4	3	4	4	4	4	3	4	4	4	4	4	4	12	2	14	1.00	1	1.00	.061	1.00	excellent		
Item45	4	4	4	4	4	3	4	4	4	3	4	4	4	4	12	2	14	1.00	1	1.00	.061	1.00	excellent		
Item46	3	4	4	4	4	3	4	4	4	4	4	4	4	4	12	2	14	1.00	1	1.00	.061	1.00	excellent		
Item47	3	4	4	3	4	4	4	4	4	4	3	4	4	11	3	14	1.00	1	1.00	.061	1.00	excellent			
Item48	4	4	4	3	4	4	4	4	4	4	4	4	4	4	13	1	14	1.00	1	1.00	.061	1.00	excellent		
Item49	4	4	4	4	3	4	4	4	4	4	4	4	4	4	13	1	14	1.00	1	1.00	.061	1.00	excellent		
Item50	4	4	4	4	4	4	4	3	4	4	3	4	4	4	12	2	14	1.00	1	1.00	.061	1.00	excellent		
Item51	2	4	2	2	3	4	4	4	2	2	2	4	4	7	1	6	8	0.57	0	0.14	18.2	0.48	poor		
Item52	3	4	4	4	4	4	4	3	4	4	3	4	4	4	11	3	14	1.00	1	1.00	.061	1.00	excellent		
Item53	4	4	4	4	4	3	4	4	4	3	4	4	4	4	12	2	14	1.00	1	1.00	.061	1.00	excellent		
Item54	4	4	4	3	4	4	4	4	4	4	4	4	4	4	13	1	14	1.00	1	1.00	.061	1.00	excellent		
Relevance	.94	.91	.91	.89	.96	.98	1.0	.93	.93	.91	.91	.91	.98	.95					S-CVIUA	.84					

The average rate of items evaluated as relevant by 14 experts after removing 5 items, S-CVI/Ave^{*}

.93

* NA: Number of Agreement; According to Ayre and Scally (2014), there is no item below the CVR=CVR_{critical} value (.571); I-CVI: Item content validity; Pc: the probability of random compromise; k*: kappa coefficient; Evaluation criteria of k*: poor ≤.39, weak = .40-.59; good = .60-.73; excellent ≥.74 according to Fleiss (1971), S-CVI/Ave* (based on proportion relevance): average proportion of “relevant” scores through experts index; S-CVI/Ave (based on I-CVI): average I-CVI scores of all items

Appendix B. First Level Confirmatory Factor Analysis for All Sub-dimensions

Items		Latent Variable	B ₀	B ₁	SH	CR	p
item45	<---	PU	.807	1.000	.071	14.649	
item 40	<---	PU	.755	.901	.071	13.271	<.001
item 4	<---	PU	.767	.922	.071	14.457	<.001
item 25	<---	PU	.769	.954	.070	15.374	<.001
item 33	<---	PU	.847	1.038	.070	15.024	<.001
item 23	<---	PU	.790	.941	.072	15.022	<.001
item 11	<---	PU	.843	1.032	.071	14.649	
item 22	<---	PU	.876	1.071	.071	13.271	<.001
item 34	<---	PU	.861	1.058	.071	14.457	<.001
item 13	<---	PU	.863	1.081	.070	15.374	<.001
item 41	<---	PEU	.743	1.000			<.001
item 28	<---	PEU	.821	1.106	.091	12.095	
item 16	<---	PEU	.840	1.080	.087	12.351	<.001
item 21	<---	PEU	.879	1.156	.090	12.910	<.001
item 19	<---	PEU	.745	.941	.086	10.886	<.001
item 20	<---	PEU	.740	.882	.082	10.734	<.001
item 32	<---	UA	.823	1.000			
item 31	<---	UA	.828	1.042	.076	13.648	<.001
item 37	<---	UA	.755	.918	.077	11.860	<.001
item 39	<---	UA	.695	.883	.083	10.643	<.001
item 38	<---	UA	.717	.876	.081	10.882	<.001
item 36	<---	UA	.745	.939	.082	11.462	<.001

β₀: standard covariance values, β₁: non-standardized covariance values, SE: Standard error, *p < .001 significant level

Appendix C. SEM Analysis Results for MVAS

Items		Latent Variable	B ₀	B ₁	SH	CR	<i>p</i>
item45	<---	PU	.446	1.000			
item40	<---	PU	.807	.901	.072	12.427	<.001
item4	<---	PU	.755	.922	.073	12.671	<.001
item25	<---	PU	.767	.954	.075	12.715	<.001
item33	<---	PU	.769	1.038	.071	14.649	
item23	<---	PU	.847	.941	.071	13.271	<.001
item11	<---	PU	.790	1.032	.071	14.457	<.001
item22	<---	PU	.843	1.071	.070	15.374	<.001
item34	<---	PU	.876	1.058	.070	15.024	<.001
item13	<---	PU	.861	1.081	.072	15.022	<.001
item41	<---	PEU	.743	1.000			
item28	<---	PEU	.821	1.106	.091	12.095	<.001
item16	<---	PEU	.840	1.080	.087	12.351	<.001
item21	<---	PEU	.879	1.156	.090	12.910	<.001
item19	<---	PEU	.745	.941	.086	10.886	<.001
item20	<---	PEU	.740	.882	.082	10.734	
item32	<---	UA	.823	1.000			<.001
item31	<---	UA	.828	1.042	.076	13.648	<.001
item37	<---	UA	.755	.918	.077	11.860	<.001
item39	<---	UA	.695	.883	.083	10.643	<.001
item38	<---	UA	.717	.876	.081	10.882	<.001
item36	<---	UA	.745	.939	.082	11.462	<.001
SEM							
PU	<---	PEU	.440	.490	.084	5.821	<.005
UA	<---	PEU	.353	.317	.065	4.865	<.005
UA	<---	PU	.446	.359	.059	6.102	<.005

β_0 : standard covariance values, β_1 : non-standardized covariance values, SE: Standard error, * $p < .001$ significant level