

A study on the design of a practical arts laboratory for elementary level technology education in Korea

In-gyu Go ^{1*} 

¹ Korea National University of Education, SOUTH KOREA

Received 12 March 2022 ▪ Accepted 11 May 2022

Abstract

This study was conducted to confirm the specifications of the laboratory and the list of practice tools for technology education in elementary schools in Korea. For effective technology education, standardized laboratory specifications and a list of practice tools are needed. However, there were no standardized laboratory specifications and a list of practice tools for elementary school students in Korea, so there were many difficulties in practicing related to technology education at the elementary level. In particular, elementary-level technology education is combined with home economic and agricultural education within the subject of practical art subjects in Korea. Therefore, the laboratory should have a complex function so that it is not only for technology education but also to enable practice in other fields. The name of the lab is "The Practical Arts Laboratory" in elementary schools in Korea. The study design and method to achieve the study purpose are as follows. First, in the theoretical analysis stage, the concept of the laboratory and considerations for designing the laboratory were confirmed through the review of previous studies. Next, a list of practice tools was derived using the big data analysis method. Then, in the actual design stage, the practical arts laboratory was designed and an expert feasibility study was conducted. The results of the study are as follows. First, the minimum area of the practical arts laboratory is 13,600mm×12,450mm, which is twice the size of a general classroom. In addition to the practical arts laboratory, a preparation room for storing practice tools is also required. The minimum area of the preparation room is 12,450mm×3,500mm, which is 1/4 the size of practical arts laboratory. Second, the practice table in the practical arts laboratory was designed as a comprehensive practice table that allows various types of practice, and the area was designed to be 600mm×1,200mm in consideration of the Korean work area. Third, the number of practice tables was set to six considering the size of the practical arts laboratory and the number of people per class in elementary schools in Korea. As of 2018, the number of people per class at an elementary school in Korea was 23.1, so four people were set to use one practice table. Practice is a key element in technology education. Thus, it will be said that the practical arts laboratory plays a very important role in Korea's elementary level technology education as an environmental background that makes the practice effective. For this reason, the standard specifications of the practical arts laboratory and the list of practice tools presented in this study are expected to contribute to the development of elementary-level technology education in Korea. Also, our results can be a reference for other countries in the world that have a similar situation to Korea.

Keywords: laboratory, technology education, practical arts, practice

INTRODUCTION

Elementary-level technology education is conducted in a complex way with home economic and agricultural education within the subject of practical arts in Korea.

Therefore, practical arts education can be said to be elementary-level technology education in Korea (Go, 2021). The practical arts are often referred to as "practice-oriented subjects" in Korea. The reason is that practice is a very important learning method in practical arts

Contribution to the literature

- This study is to suggest concrete alternatives for elementary schools through systematic research on the laboratory and the list of practice tools and to improve the quality of practical art education and elementary level technology education.
- This may be meaningful in that it revealed what should be considered not only in terms of architectural engineering and ergonomics but also in terms of education.
- The case of Korea presented as a result of this study can be used as basic data for preparing a laboratory and practice tools for technology education in other countries.

education. It will not be possible to achieve its purpose if the classes in practical arts education are conducted only in the form of explanations and lectures. This is because the learning contents of the practical arts classes are mainly composed of practice-oriented courses. This is also true of original technology education. ITEA (1996) defines the concept of technology as an activity in which humans utilize products or systems. Therefore, practice is important to fully achieve the purpose of technology education.

The laboratory is a space for maximizing the educational effect of practice, and it is a very important element to achieve the educational purpose in the practical arts (the elementary level technology education in Korea), which is a practice-oriented subject (Jeong, 2003). However, there are not many elementary schools equipped with a laboratory for practical arts in Korea, and this causes problems in which practical training is not performed properly in the practical arts. The number of schools with a laboratory for practical arts in elementary schools in Korea was 67.2% of the total, but these results include cases where general classrooms were used as a laboratory for practical arts. And about 71% of schools with a laboratory for practical arts were operating a very small size laboratory. This is about the size of one general classroom (Lee, 2013).

Because of these problems, there was a demand for continuous improvement of the laboratory for practical arts in the education field in Korea. The education authorities also recognized this problem, and after the 2009 revised practical arts curriculum, contents related to the establishment of the laboratory were newly added to the practical arts curriculum. As a result, the legal and institutional basis for the establishment of the laboratory for practical arts was prepared. For this reason, most of the new schools are equipped with a laboratory for practical arts, and existing schools are also creating a new laboratory for practical arts. However, it should be noted that there is no standardized standard for the educational point of view of the laboratory for practical arts, so there is a problem that only an activity space for practice is secured, not a conceptualized space to achieve the educational purpose. Practice tools are also similar for the same reason, and various practice tools are needed for practice classes, but the reality is that there are no standardized guidelines in the process of

equipping the practice tools, so there are many difficulties in the school field.

The practical arts consist of technology education, home economics, and agriculture. Therefore, it is important that the laboratory for practical arts be equipped with a comprehensive room where various types of practice can be performed, and that the practice tool is suitable for each educational activity. However, there is indeed no standardized specification of laboratory and list of practice tools for practical arts, so it is difficult for practical arts education or elementary level technology education in Korea. This study was conducted to solve this problem, and the results derived from this study can be an important reference for researchers in other countries.

THEORETICAL BACKGROUND

The Concept of Laboratory

A facility for technology education can be defined as the physical environment of a school installed so that the educational activities necessary to achieve the purpose of technology education can be smoothly performed. Its main purpose is to provide students with an optimal technological learning environment, provide sufficient space and facilities for students to have a variety of technology-related learning experiences, and maintain a comfortable learning environment. The facilities for technology education consist of three parts: a classroom, a laboratory, and an auxiliary room (Polette, 1991). Among them, the main focus of this study is a laboratory. The reason why the laboratory is important in technology education is that, unlike general subjects, technical thinking and practical skills are important for technology subjects, and practical skills are nurtured through various practices (Go, 2021). Therefore, the laboratory is a very important factor in determining the success or failure of technology education.

The laboratory for technology education is divided into three types: a unit laboratory, a general laboratory, and a comprehensive laboratory according to the educational purpose pursued (Gemmill, 1989). The unit laboratory is a type of facility designed to perform manual skill practice for one specific subject. In general, it is organized around the machines or devices necessary for the practice of a specific subject, and the tools

necessary for the practice are arranged so that they can be used individually. The main purpose of the unit laboratory is to acquire the professional skills necessary for professional life. Therefore, it is mainly installed in vocational schools, vocational training centers, vocational colleges, and general universities. Types of the unit laboratory include welding laboratory, lathe laboratory, casting laboratory, and CAD laboratory. A general laboratory is a group of 2-3 unit laboratories. It is an educational facility designed to provide a variety of learning experiences in materials, specific subject areas, and related to the industry. For this reason, various machines and devices necessary for practice are effectively organized in the general laboratory. In addition, the tools necessary for practice should be arranged so that they can be used jointly. The general laboratory is mainly found in vocational high schools, colleges, and universities for higher education, such as colleges and universities. Types of the general laboratory include machine work laboratory, general design laboratory, and electrical/electronic laboratory. The comprehensive laboratory is a type of facility designed to give an overall understanding and experience of facts and concepts related to technology. The comprehensive laboratory is equipped with sufficient space and facilities for overall experience activities related to manufacturing, construction, transportation, communication, and life-related technologies. In general, the comprehensive laboratory has an ancillary room. The ancillary rooms are not where teachers and students directly develop class but refer to spaces that support and assist with the things necessary for class. The type of ancillary rooms includes a teacher's room for class preparation and office activities, a storage room for storing materials, tools, and equipment used in class, and a storage room for storing various materials necessary for class.

Ergonomic Considerations for Laboratory Design

Educational facilities are inevitably required through teaching-learning to effectively operate the curriculum. Kim (1992) emphasized the need for an ergonomic approach to contribute to providing students with a pleasant environment in educational facilities. Ergonomics can also be called engineering to utilize humans. More precisely, it is to design machines or facilities so that humans can work most efficiently (Wesley, 1981). In the United States, the term "human factors" is used for ergonomics, but in Europe and other countries, "ergonomics" is used. Some people distinguish between the two, but in reality, they mean the same thing. In other words, it aims to increase the efficiency and effectiveness of human activities and improve human values, and it can be said that it is a study that focuses on the interaction between humans and the environment (Sanders & McCormics, 1993). However, the workbench, chair, toolbox, blackboard,

and data box used in the laboratory so far have been standardized regardless of the student's physical development, learning content, and learning from. Health-related facilities such as climate control and lighting facilities have shapes and structures that are not related to classroom orientation or building structures. Rather than providing an educational environment for students, this is the minimum facility to comply with laws related to school facilities.

The laboratory can be viewed as an individual or aggregate structure and action of external conditions and stimuli that have a positive educational effect on individuals. Therefore, the laboratory should be installed comfortably and safely to have a positive effect on users (Gardner, 1985; Gemmill, 1989; Polette, 1993; Schriber, 1987; Tamimi, 1990).

In a broad sense, the educational environment can be said to be a part of education centered on teaching and learning. This becomes an area that plays a psychological role as a space to form a positive relationship between students and teachers and a friendly learning environment. Therefore, the educational environment is established by two aspects, and the facilities and environment of the laboratory must also be planned following the characteristics of the user's psychological aspects. In other words, the design of the laboratory should be appropriate for the psychological and physical developmental stages of the students who will use it. In addition, there must be ergonomic considerations that ensure safety, aesthetics, health, etc. so that all functions performed at schools, such as educational methods, operational management organizations, and daily life forms can be understood and have high-level educational effects.

General Considerations for Laboratory Design

When designing facilities for technology education, feasibility, flexibility, safety, and efficiency should be considered. The first is validity. The validity of an educational facility refers to the degree to which the elements necessary to operate an educational program are sufficiently equipped in quantity and quality, the shape and atmosphere of the facility suitable for education, and the degree of organic relevance of the facility. As the fundamental purpose of a technology education facility is to achieve the educational purpose, it is necessary to consider its feasibility first. Polette (1993) emphasized the planning of space arrangement appropriate to the formation of a friendly learning atmosphere while securing the learning space and facilities necessary for the operation of technical subjects to increase the validity of the technical education facility.

The second is flexibility. The flexibility of educational facilities relates to the degree to which they can accommodate changes in the curriculum based on changing educational needs (Gardner, 1985). Cumming

et al. (1987) presented flexibility as one of the evaluation criteria for technical education facilities that can satisfy future needs and use space efficiently based on their own experiences. To efficiently operate technology subject classes and to become a facility that can be redesigned according to the continuous development of technology, flexibility in relocating space according to changes in curriculum, teaching methods, and student's needs is important (Gemmill, 1989).

Third, it is safety. The safety of educational facilities is the degree to which the safety of the structure or use of the facilities is guaranteed to prevent safety accidents for students. The practice of technology subjects contains many risk factors in light of the nature of the activity, such as the tools, materials, and activities with which students are handled. Therefore, it is necessary to secure sufficient space for practice, manage teachers' classes, and plan for the movement of students. In addition, adequate ventilation, lighting, and humidity control are required to prevent student health or equipment failure (Lyu et al., 2014).

Fourth, is efficiency. The effectiveness of educational facilities is related to the maintenance and management of the facilities and the management of instructional materials (Gardner, 1985). Technology education facilities equipped with expensive equipment and dangerous tools should enable teachers to easily and effectively perform management activities, and share learning resources with other subjects to increase the effectiveness of learning. In addition, as the role of the school is expanding, it should be designed so that it can be used outside of regular classes.

Special Considerations for Laboratory Design

The laboratory to be developed in this study is a laboratory in which the special consideration of

elementary level technology education is taken into account. Therefore, it is necessary to examine the specificity of Korea's elementary level technology education and to reflect this in the design of the practice room. In Korea, elementary-level technology education takes place within the subject of practical arts (Go, 2021).

The content system of practical arts is largely composed of 'world of technology' and 'family life'. Elementary level technology education is conducted in the World of technology and mainly deals with manufacturing technology, transportation technology, and information and communication technology. Elementary level technology education in Korea emphasizes the connection with real-life through creative experience activities. It also aims to cultivate technological literacy and to cultivate advanced thinking skills such as creativity and problem-solving ability (Kwon, 2011). Therefore, the laboratory should reflect the special characteristics of Korea's elementary-level technology education.

In Korea, elementary level technology education is tied to various fields such as agriculture, home economics, environmental education, and career education within the subject of the practical arts, so it is easy to access convergence with other fields. Therefore, the laboratory for elementary level technology education should be a comprehensive space where not only technical education activities occur but also where other activities can be performed (Ryu, 2000).

RESEARCH METHOD

In this study, the research method as shown in Figure 1 was applied to derive a list of practice room design and practice tools for elementary level technology education in Korea.

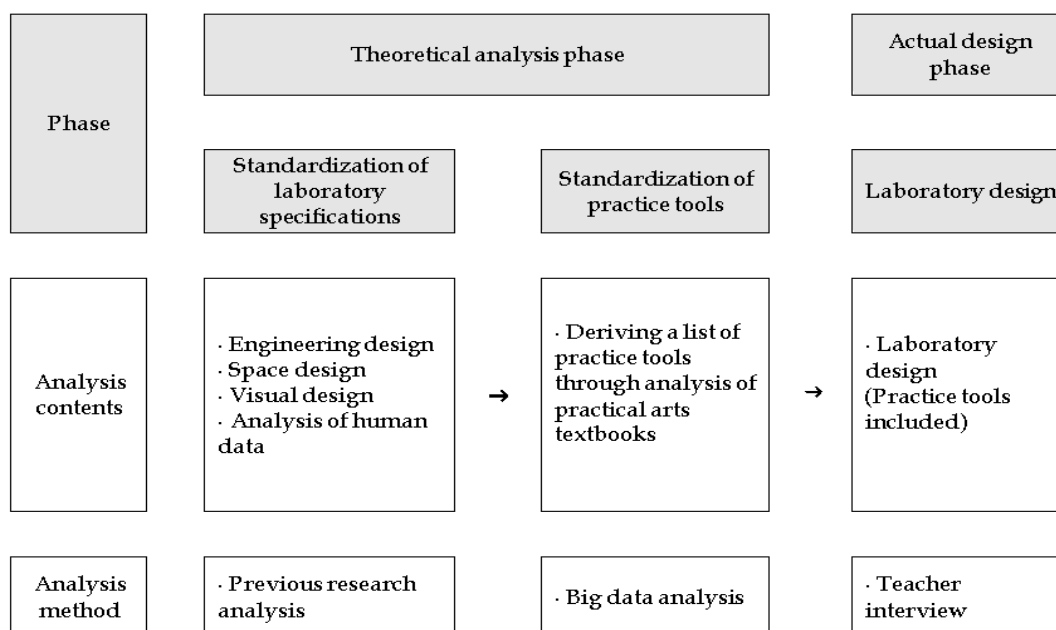

Figure 1. Research method

Table 1. Textbooks to be analyzed

Publisher	Textbooks
KYOHAK EDUCATION https://www.kyohak.co.kr/	<ul style="list-style-type: none"> · Grade 5 Practical Arts Textbook · Grade 6 Practical Arts Textbook · Grade 5 Teacher’s Guide for Practical Arts Textbook · Grade 6 Teacher’s Guide for Practical Arts Textbook
VISANG EDUCATION https://www.visang.com/	<ul style="list-style-type: none"> · Grade 5 Practical Arts Textbook · Grade 6 Practical Arts Textbook · Grade 5 Teacher’s Guide for Practical Arts Textbook · Grade 6 Teacher’s Guide for Practical Arts Textbook
CHUNJAE EDUCATION https://www.chunjae.co.kr/	<ul style="list-style-type: none"> · Grade 5 Practical Arts Textbook · Grade 6 Practical Arts Textbook · Grade 5 Teacher’s Guide for Practical Arts Textbook · Grade 6 Teacher’s Guide for Practical Arts Textbook

Table 2. Characteristics of interviewed teachers

Participants	Area of expertise	Educational experience	Affiliated organization
Teacher 1	Practical arts education (Doctor of pedagogy)	20 years	Elementary school
Teacher 2	Practical arts education (Doctor of pedagogy)	20 years	Elementary school
Teacher 3	Technology education (Masters of pedagogy)	20 years	Middle school
Teacher 4	Educational administration (Doctor of pedagogy)	18 years	Elementary school
Teacher 5	Engineering	10 years	Elementary school

Theoretical Analysis Phase

In the theoretical analysis phase, literature and previous studies related to the laboratory and practice tools were reviewed. Through this, the conceptual definition of the laboratory and the meaning of its educational functions were established, and operational cases related to the provision of the laboratory and practice tools were confirmed. The concepts of engineering, space, vision, and human body data were analyzed as factors to be considered before designing the laboratory, and this was applied in the actual design stage. In other words, theoretical analysis became the basis for the design of the laboratory. The standardized list of practice tools was derived through big data analysis. For big data analysis, frequency analysis was carried out by dividing the current three types of practical arts textbooks into four areas: home economics, clothing, agricultural, and technology in consideration of the academic field of practical art subjects. KrKwic (Park & Leydesdoff, 2004) was used for the analysis program.

For data analysis, one of the big data analysis methods, text mining, was applied. Text mining is an analysis method that finds meaningful information by extracting patterns or relationships from unstructured text data composed of natural language based on natural language processing technology (Go, 2018). The process of text mining is carried out in four stages: information collection, information processing, information extraction, and information analysis. First, in the information collection process, text data identified as the research subject is collected. Second, in the information processing process, the text is processed into a data format suitable for the intended research direction.

Third, in the information extraction process, an entity name is extracted using a mathematical algorithm. Fourth, in the information analysis process, meaningful entity names are selected from the extracted entity names and the calculated results are visualized (Lee et al., 2016). In this study, after mining the contents of practical textbooks (Table 1), practice tools appearing in practical textbooks were extracted using the KrKwic program.

Actual Design Phase

In the actual design phase, the laboratory was designed based on the contents of the theoretical analysis phase. When designing the laboratory, engineering, spatial, and visual aspects were considered, and the area of the laboratory and the size of the lab were designed through the analysis of Korean human body data. The laboratory is a space for practice, but at the same time, it is a complex place where educational activities take place. Therefore, it is important to listen to the opinions of teachers in designing the laboratory. In this study, five teachers were recruited and interviewed. Through this, we listened to suggestions for improvement or suggestions related to the operation of the laboratory. The characteristics of the five teachers interviewed in this study are shown in Table 2.

Participants 1, 2, and 3 were teachers with more than 20 years of educational experience and were mainly advised on the design of the laboratory and the composition of the space. Participant 4, a teacher with 18 years of educational experience, was advised on the operation of the laboratory in terms of educational administration. The last, participant 5, a teacher with 15 years of educational experience, was consulted about

furniture placed in the laboratory from an engineering perspective.

THEORETICAL ANALYSIS RESULTS

Spatial Design

Educational facilities require sufficient space in consideration of the physical and psychological characteristics of students and the diversity of learning developed by teachers and students. Therefore, since the practical activities within the technology education facility have a higher risk of accidents compared to other subjects, the issue of space security should be treated with great importance. In the practice classes of the technology subject, students handle various tools, materials, etc., and move as needed. In addition, since there is a high risk of accidental accidents when immersed in activities, it is necessary to properly apply the workspace when designing facilities. The study space applies the required area per student in addition to the body size. Spaces for theory classes are generally designed with an area of 1-2.5m² per student (Beynon, 1994). Han (1995) suggested securing a space of at least 2 m² per person in consideration of the diverse needs and personal characteristics of students. The laboratory of the technology subject needs a larger space in preparation for safety accidents that occur during class. In consideration of the aisle and workspace, it is appropriate for the technology subject laboratory to be about 4m² per person (Lee et al., 1999).

Flat Design

The technology education facility is composed of classrooms, laboratories, and annexes, and the space required by each component includes several things. Traditionally, the spaces constituting technology education facilities have a closed space structure, and the

laboratory is located far from the classroom due to noise and dust generated during class (Polette, 1993). However, in recent facilities, classrooms and laboratories are integrated, and the spaces composing the facility do not have separate walls or are movable walls, forming an open space structure that can move freely between spaces (Gemmill, 1989). Facilities for technology education must be able to apply a variety of teaching strategies and methods. For this reason, the Maryland State Department of Education (1994) in the USA recommends that technology education facilities be adjacent to science and math education facilities. In addition, the following areas were included to apply various teaching methods.

1. Classroom area
2. Small group meeting area
3. Design area
4. Research area
5. Modular instructional activities areas
6. Dynamic testing area
7. Production/fabrication area

Essential support spaces for technology education include

1. Teacher office space
2. Material storage room
3. Product storage room
4. Finishing area

The 11 areas can be applied with a different arrangement of types of facilities according to the school level and the number of students that can be accommodated. **Figure 2** is a model of a technology education facility that can study 24~28 middle and high school students suggested by the Maryland State Department of Education (1994).

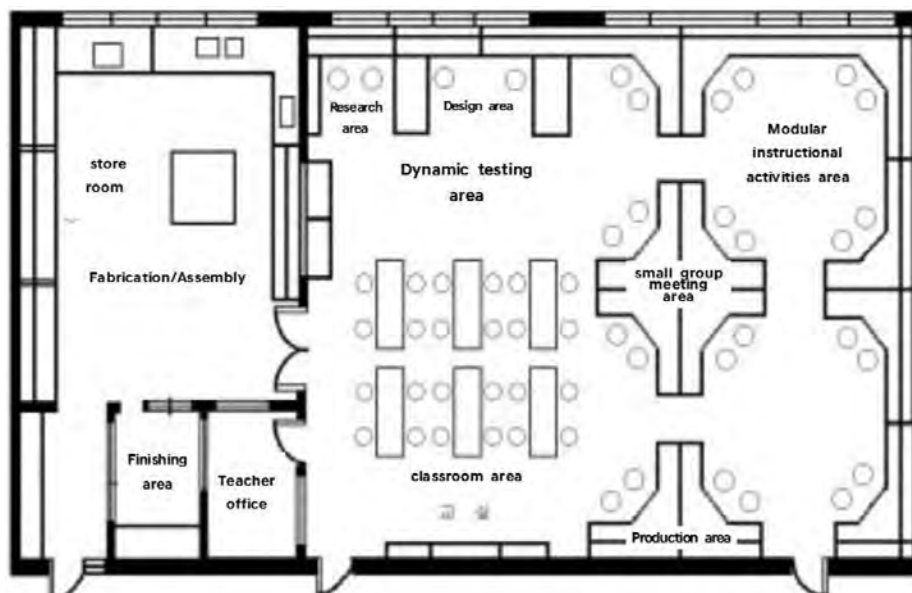

Figure 2. Technology education facility

Polette (1993) stated that the annexes such as design and resource area, class area, material and product storage area, material process area, and office area are needed in the laboratory related to technology education. The shape and size of the technology education facility are determined by the education plan, and the space to be included in the facility consists of the main training room, teacher's room, lecture room, tool room and material room, and data room (Lee et al., 1999). In addition, Shin and Kim (1992) stated that a rectangular shape is good for good movement, and pillars, protrusions, or partition walls that obstruct the line of sight should not be installed. It was said that the following should be considered for the organic movement:

1. There must be a wide passage for important movement.
2. It must be possible to transport tools and materials without interfering with other work.
3. A certain interval should be maintained between major operations.
4. The traffic line should be arranged in a straight line so that the dangerous area can be passed as quickly as possible.
5. Long materials must be rotated by 90° or can be transported by students without colliding with them.

Visual Considerations

To protect the eyes of students who are still growing and developing, the most important thing is the brightness of the facility. The brightness of a facility is determined by natural and artificial lighting, and for a pleasant learning environment, the brightness must be uniform (Castaldi, 1987). The brightness of the facility depends on the nature of the learning activities the students engage in. In the case of Korea, it is stipulated that the brightness of school facilities be maintained at 300[lx] or higher to maintain the normal eyesight of students. When the human eye is directed forward, the field of view that can recognize an object is limited to about 124° as shown in **Figure 3**. Therefore, to improve communication between teachers and students and the effectiveness of classes, it is good to determine the size of the space and the arrangement of desks and chairs in consideration of the limitations of the field of view. In addition, the maximum distance that students can recognize 4cm-sized letters written on the blackboard is 9m, and the width that the teacher can recognize all students at the same time is about 7.5m (Han, 1995). It is necessary to consider these visual factors in determining the size of the classroom space. Noise is also important, and Castaldi (1987) considered the following when designing educational facilities for noise control of educational facilities:

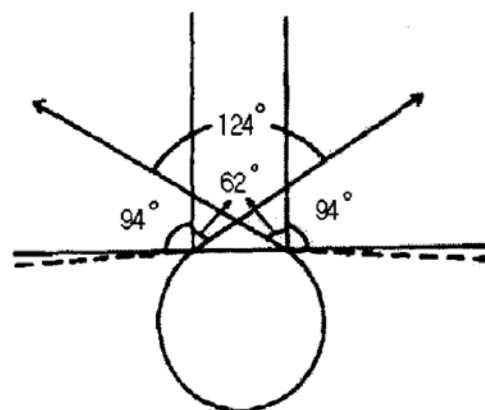

Figure 3. Visual considerations (Park, 2001)

1. Select a school site away from noise sources.
2. Remove the noise from the noise source.
3. Separate noisy and quiet places.
4. Isolate noise-generating equipment.
5. Install soundproof walls.

Communication in technology subject class activities is mainly performed by sound, and if noise occurs during practice, it interferes with class and causes accidents, so it is necessary to control noise (Storm, 1993).

Design Based on Anthropometric Data

Anthropometric data can be widely applied to the design of equipment or equipment. It is a practice to use a solid model, such as a jointed model, usually representing a specific percentile. When using these materials, designers should choose materials from a group similar to the people they will use. In addition, there are three principles for selecting target materials according to specific design problems. The first is the design for adjustable range. Some equipment should be adjustable to fit several people of different physiques. Examples are fore-aft adjustment of car seats and up-adjustment of office chairs. When adjusting, it is customary to design items in the range of 90% from 5% to 95%.

The second is design for extremes. When designing a specific facility, it is often possible to accommodate almost everyone if it is designed for people who belong to one extreme of certain anthropometric characteristics. For installations or other designs for population values, 90, 95, or 99% of the relevant anthropometric parameters for the target population are usually used as a reference for the upper percentile. Typical maximum population values are used to define space margins such as doors, exits, and passages. At this time, if the facility in question can accommodate large people, all smaller people are accommodated. In addition, the design for the minimum population is determined based on the lower percentiles, such as 1, 5, or 10% of the distribution of the relevant anthropometric variables. Typical minimum group values are the height of the shelf, the height of the

Table 3. List of practice tools

Dietary	Clothing	Agricultural	Technology
· Bowl (16*)	· Thread (26)	· Flower pot (27)	· Robot (279)
· Knife (12)	· Button (20)	· Soil (15)	· Sensor (71)
· Cup (11)	· Needle (19)	· Fertilizer (14)	· Bike (29)
· Microwave (12)	· Scissors (11)	· Seeds (12)	· Electric motor (13)
· Gas stove (6)	· Needle (10)	· Shovel (10)	· Knife (11)
· Measuring spoon (6)	· Crochet (9)	· Manure (8)	· Smartphone (9)
· Measuring cups (6)	· Cloth (8)	· Sprinkler (8)	· Computer (9)
· Ladle (6)	· Scissors (6)	· Gravel (8)	· Foam board (8)
· Rice bowl (5)	· Cross stitch (6)	· Seedlings (7)	· Scissors (7)
· Dish (5)	· Dice (6)	· Soil (7)	· Wood rock (7)
· Pot (5)	· Pin (6)	· Fish tank (6)	· Glider (6)
· Electric rice cooker (4)	· Hour pin (5)	· Thermometer (6)	· Umbrella (6)
· Chopsticks (4)	· Choke (5)	· Work gloves (4)	· Vacuum cleaner (6)
· Steamer (4)	· Sewing machine (4)	· Cage (4)	· Top (6)
· Spoon (3)	· Nonwoven (3)	· Bucket (4)	· Leggings (5)

Note. *In this study only tools with frequency three or higher are indicated

Table 4. CVR value

Number	Items	N	Average score	Ne*
1	Dietary	10	5.00	10
2	Clothing	10	4.80	10
3	Agricultural	10	4.80	10
4	Technology	10	4.80	10

Note. *Ne is the number of respondents who answered 4 or 5 on the Likert scale out of 5

elevator buttons, the height of the chair, and the distance to the controls. The third is design for average. In the case of specific equipment, when it is inappropriate to design based on the maximum or minimum group value and there are cases when it is necessary to design it based on the average value. For example, a bank's counter made for customers of average height will be less inconvenient for most regular customers than those made for dwarfs or giants (Park, 2001).

Data Analysis for Standardization of Practice Tools

Big data analysis

In this study, text mining analysis was performed on practical textbooks using the KrKwic program of Park and Leydesdoff (2004) for the standardization of practical tools. The analysis was carried out by dividing four areas (home economics, clothing, agricultural, and technology) into three types of practical arts textbooks. Through this, the types of practice tools used in practical art subjects were confirmed. The results are shown in the following **Table 3**.

Expert content validity ratio values

In this study, an expert content validity ratio (CVR) test was performed to verify the validity of the list of practice tools derived through big data analysis. As experts, 10 elementary school teachers were recruited, and it was conducted through e-mail. The results of CVR value test of the expert group are shown in **Table 4**.

The validity of the derived practice tool was determined according to CVR suggested by Lawshe (1975). The CVR formula is as follows:

$$CVR = \frac{N_e - \frac{N}{2}}{\frac{N}{2}}$$

In this study, the number of panelists who participated in the content validity test was 10. Therefore, the study result is judged valid only when the minimum value of CVR is .62 or higher (Lawshe, 1975). As a result of the test, the CVR value was .99, confirming that the results of this study were very valid. However, the final list of practice tools has been revised and supplemented to reflect the detailed opinions of the expert group. Expert opinions are shown in **Table 5**.

The final list of practice tools

The final list of practice tools that combines the above big data analysis results and expert panel opinions is shown in **Table 6**. In this study, special woodworking tools were added. Although the contents related to woodworking education were deleted from the Korean curriculum revised in 2015, the opinion of experts was that woodworking education was necessary for elementary schools. Therefore, a list of woodworking tools was additionally presented concerning the studies of Lee et al. (2015).

Table 5. Expert opinions and corrections and supplements

No	Items	Expert opinion	Corrections & supplements
1	Dietary	· Since there are many experimental elements in practice of dietary area, it is suggested to additionally have tools enabling precise measurement.	· Add thermometer, electronic scale, & stopwatch to list
2	Clothing	· No comments	
3	Agricultural	· Add rake & mattock, which are essential for cultivation activities.	· Add rake & mattock to list
4	Technology	· Add woodworking-related tools regardless of curriculum.*	· Add woodworking tools

Note. *Woodworking was excluded from Korea’s 2015 practical arts curriculum

Table 6. The final list of practice tools

Analysis method	Area			
	Dietary	Clothing	Agricultural	Technology
Big data analysis	· Line · Button · Needle · Side scissors · Large needle · Crochet hook · Fabric · Scissors · Cross stitch · Dice pin · Hour pin · Choke · Sewing machine · Non-woven	· Bowl · Knife · Cup · Microwave · Gas range · Measuring spoon · Measuring cup · Ladle · Rice bowl · Dish · Pot · Electric rice cooker Chopsticks · Steamer · Spoon	· Flowerpot · Culture soil · Fertilizer · Seed · Trowel · Manure · Watering can · Pebble · Seedling · Soil · Fishbowl · Thermometer · Work gloves · Cage · Bucket	· Robot · Sensor · Bicycle · Electric motor · Knife · Smartphone · Computer · Foamboard · Scissors · Woodrock · Glider · Umbrella · Vacuum cleaner · Top · Timber · Drill
Expert opinion	· No comments	· Thermometer · Electronic arm · Stopwatch	· Lake · Mattock	· Drill · Hammer · Clamp
Literature review	· Sewing scissors · Iron · Ruler · Tape measure · Cloth	· Sieve · Tongs apron · Head towel · Frypan · Cutting board	· Growing box · Pruning shears · Trowel · Sickle	· Woodworking tools presented separately*

Note. *Band saw, double-blade saw, hammer, woodworking lathe, jigsaw, acrylic bending machine, disk sand, triangular ruler, woodworking kit, SCSI saw, rat-tail saw, band saw machine, nail, pliers, air compressor, screwdriver, heated wire cutter, engraving knife

The Design of a Practical Arts Laboratory for Elementary Level Technology Education in Korea

The size of the practical arts laboratory

The size of the laboratory is determined by the number of students (Korea Research Institute of Standards and Science, 2009). According to the Korea Statistical Information Service (2016), the number of students per class at an elementary school in Korea was 23.2. Based on this, it is desirable to install and operate six laboratory tables, where four people can sit. It is desirable to arrange the laboratory table in 2×3 units and to secure a space between the laboratory table and the laboratory table that is twice the shoulder width of two students in consideration of the case where two students

cross each other. It is also necessary to consider the case of moving with a chair. Accordingly, a space twice (360mm×2=720mm) the width of the chair seat set in 1520mm, which is the average height of 6th-grade students of an elementary school in Korea, is secured. In addition, extra space is added assuming that the desk is moved together. In this case, the minimum width of the desktop is 450mm. Therefore, the distance between the training tables should be arranged at least 2,030mm apart by adding up all of these cases (Table 7).

The width between the table and the hallway is 1,530mm in total, including the width of the student chair (340mm), twice the width of the student’s shoulder (380mm×2=760), and the width of the teacher’s shoulder 410mm. Secure a cultivation practice space with a length

Table 7. KS dimension list

KS	Height	Desk height	Chair height		Desk width	Chair width
			Knee height	Shin height		
1	1,050	460	350	350	450	260
2	1,200	520	410	350		290
3	1,350	580	470	400		300
4	1,500	640	530	400		300
5	1,650	700	590	450		350
6	1,800	760	650	500		350

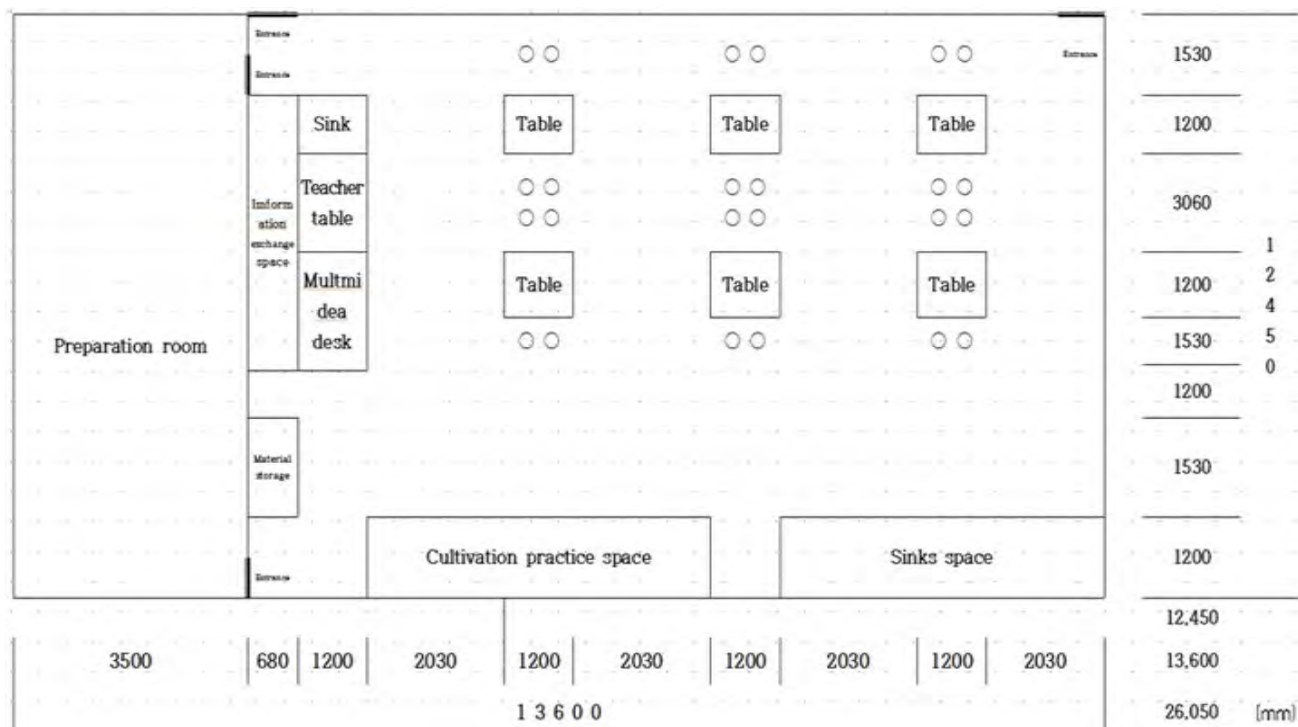

Figure 4. The practical arts laboratory plan

of 5,260mm and a width of 1,200mm toward the window. The reason for securing the cultivation practice space is to enable cultivation practice indoors regardless of fine dust and weather. Rather than using multiple sinks separately, it is better to collect them in one place and install them intensively. This allows for more efficient use of the sink and makes student guidance and collaborative learning easier.

The teacher’s table suggested a way to use it as an ‘information exchange space’. This is to enable two-way information exchange between teachers and students and between students and students, rather than unilateral information transfer by teachers. Therefore, considering all this, the minimum area of the size of a laboratory is 13,600mm×12,450mm, which should be designed to be twice the size of a general classroom. And the preparation room is 12,450mm × 3,500mm and should be designed to occupy 1/4 of the laboratory. In the preparation room, shelves for various practice tools are installed, and furniture for teachers’ rest can be arranged. **Figure 4** shows practical arts laboratory that combines the above.

The design of the table

The length of the table was designed to be 1200mm considering the case of two people sitting. This was based on the maximum working area dimension of Koreans (600mm, an average of 621mm for men and 579.1mm for women). The width of the table is set to 900mm so that two people can work. This is a figure obtained by adding 38mm from the double of 431mm by subtracting 190mm of the space between the workbench and the student from the maximum male working area of 621mm (**Figure 5**).

Electrical outlets should be installed on both sides of the table, and drawers should be installed in the lower part so that they can be used for unit learning related to clothing. By installing a locker space in the lower center of the table, it should be designed as a space that can be used easily by putting a toolset or a sewing machine.

The design of the sink

The sink should be designed to be used in the cooking area or gardening area. The most suitable height of the

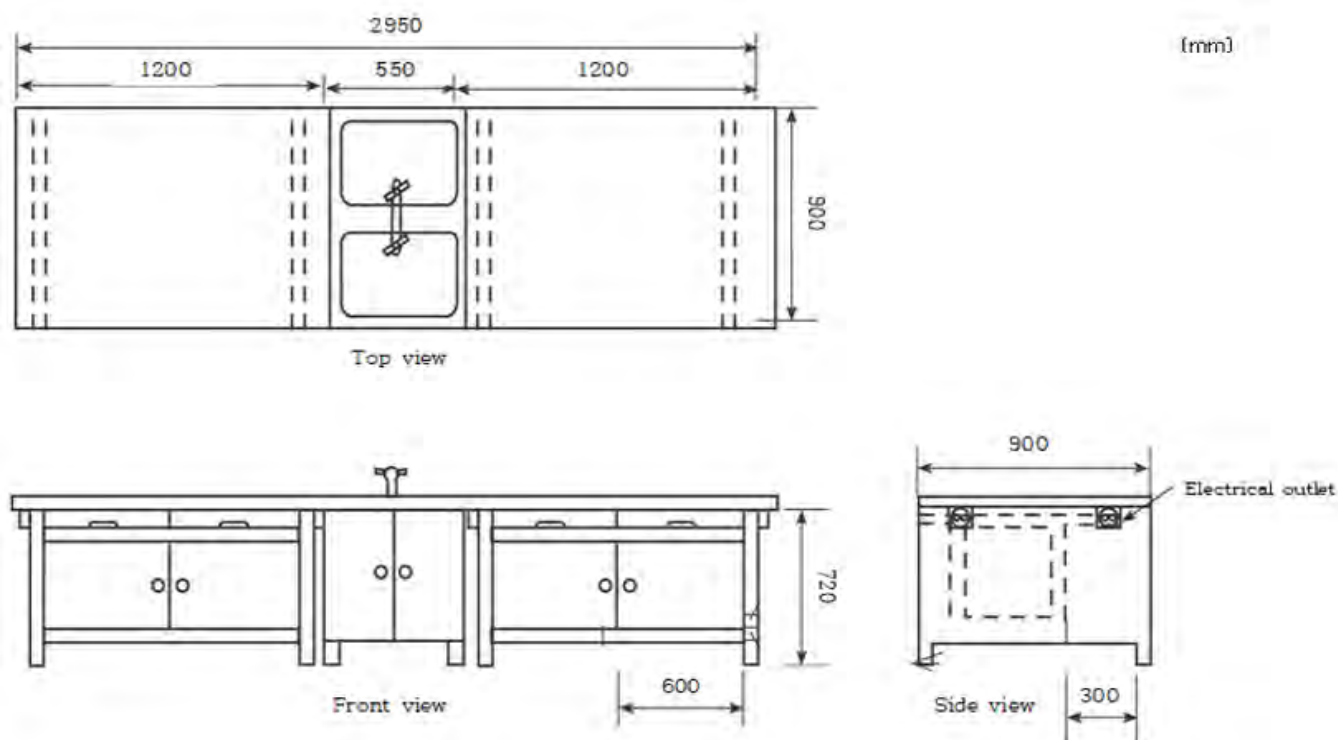

Figure 5. The table plan (Chung, 2004)

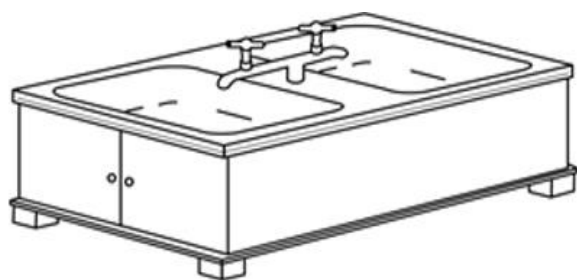

Figure 6. The sink plan (Chung, 2004)

sink is 50-54% of a person's height. The width and length of the sink should be the size that students can use conveniently, the faucet should be connected to something that can be used conveniently, and a cover should be made to cover the sink when not in use. The outside dimensions of the sink should be designed to be 550mm×450mm and the inside dimensions to be 430mm×350mm (Figure 6).

The design of the chair

The appropriate height of a chair in the practical arts laboratory is 'calf height' or '1/4 of a person's height'. The width of the chair can be calculated as 'height below the calf×0.87'. Accordingly, the length of a chair is 350mm and 390mm, the width of the chair is 300mm and 340mm, and the height of the chair is 330mm, 350mm, and 370mm (Figure 7).

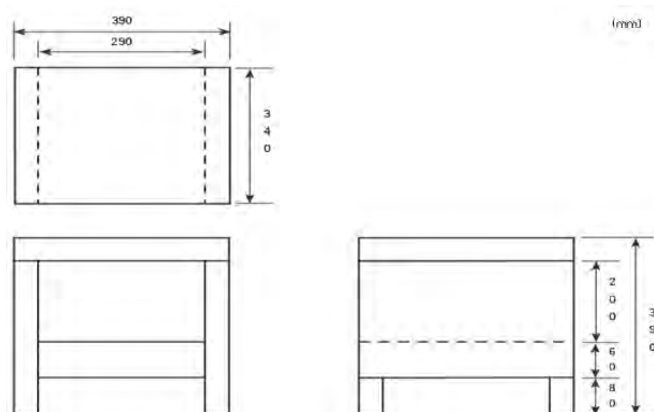

Figure 7. The chair plan (Chung, 2004)

The design of the teacher's table

The height of the teacher's table is 750-800mm (about 5cm higher than the teacher's height of 165-170cm×0.43), the length is 1,800-1,900mm, and the width is 900-1,000mm so that the students can observe the teacher's demonstration. Drawers should be attached to accommodate frequently used items or materials. Drawers should be attached to bottom of teacher table to store frequently used tools and materials (Figure 8).

Electrical installations and lighting

The power supply of the practical arts laboratory is essential, and it is necessary for activities in various fields such as woodworking, clothing, and cooking. The power equipment of the laboratory should be installed by calculating the total capacity used.

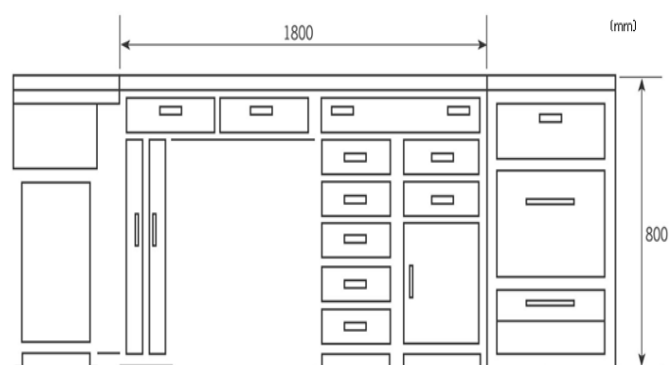

Figure 8. The teacher table plan (Chung, 2004)

'Computer', 'monitor', 'printer', 'real imager', 'TV', 'induction', etc. should be added to calculate the total power consumption of the practical arts laboratory. And for the maximum load current, when the voltage is 220V, it is necessary to consider the degree to which 10 LED lights, six inductions, computer, monitor, refrigerator, etc. can be used simultaneously (Kim et al., 1997). Lighting in the laboratory is one of the things that must be scientifically identified to improve the efficiency of learning and for the health and safety of students. We recommend 150-300 lux as a lighting level suitable for school labs, and we suggest installing and operating lighting equipment regarding this.

CONCLUSION

Elementary-level technology education in Korea is conducted in practical arts classes. Practice in practical arts mediates the characteristics of practical arts education, and it would not be an exaggeration to say that classes in practical arts education are practical lessons. Therefore, it is essential to design the practical arts laboratory where the practice takes place and to standardize the practice tools to improve the quality of the practical arts education. And this is also related to the development of primary-level technology education. The practical arts laboratory for technology education in Korea has not been the focus of our interest for various reasons. However, starting with the 2015 revised curriculum, it began to have a legal and documentary binding force to improve technology education and laboratories. As a result, almost all new schools currently have practical arts laboratory. Therefore, the purpose of this study is to suggest concrete alternatives for elementary schools through systematic research on the laboratory and the list of practice tools and to improve the quality of practical art education and elementary level technology education. The methods applied to achieve the purpose of the study are literature review, big data analysis, and expert interview. And through this, standardized specifications for the laboratory and the list of practice tools were presented. This may be meaningful in that it revealed what should be considered not only in terms of architectural engineering

and ergonomics but also in terms of education. The specifications of the laboratory and the list of practice tools proposed in this study are not to be imposed on schools. It is important to design the laboratory and equip it with practical tools following the school's situation and educational focus. Nevertheless, what the results of this study can have significance is that there has been no systematic study on technology laboratories worldwide. The results of this study will serve as basic data for the technology laboratory and practice tools. The case of Korea presented as a result of this study can be used as basic data for preparing a laboratory and practice tools for technology education in other countries. De Vries et al. (2016) described the reality that technology education is not recognized in subject education as a 'The Evil world'. The only way for technology education to survive in an evil world is to acquire superior skills. The laboratory can be an important weapon for technology education or practical arts education. Now that maker education has emerged as a trend, technology education is receiving attention again in the education field. The time is now, the opportunity to improve practical arts education should not be missed.

Funding: No funding source is reported for this study.

Declaration of interest: No conflict of interest is declared by the author.

REFERENCES

- Beynon, J. (1994). Facilities and physical plant. In T. Husen, & T. N. Postlethwaite (Eds.), *The international encyclopedia of education*. Pergamon.
- Castaldi, B. (1987). *Educational facilities: Planning, modernization, and management*. Allyn and Bacon.
- Chung, S. (2004). *Principles of practical arts education*. Kyohaksa.
- Cumming, P., Jensen, M., & Todd, R. (1987). Facilities for technology education. *The Technology Teacher*, 46(7), 1-20.
- De Vries, M. J., Fletcher, S., Kruse, S., Labudde, P., Lang, M., Mammes, I., Max, C., Münk, D., Nicholl, B., Strobel, J., & Winterbottom, M. (2016). *Technology education today: International perspectives*. Waxmann.
- Gardner, D. (1985). Educational facilities. In T. Husen, & T. N. Postlethwaite (Eds.), *The international encyclopedia of education*. Pergamon.
- Gemmill, P. R. (1989). From unit shop to laboratory of technologies. *The Technology Teacher*, 50(8), 3-14.
- Go, I. G. (2018). Big data analysis of standards and standards education by text mining. *Journal of Standards, Certification, and Safety*, 8(4), 19-32.
- Go, I. G. (2021). Analysis on trends of technology education shown in national curriculum at the elementary level in the Republic of Korea. *International Journal of Technology and Design*

- Education*, 31(1), 223-254. <https://doi.org/10.1007/s10798-019-09555-z>
- Han, E. S. (1995). An analysis of factors in class room design based on human engineering. *Journal of Korean Institute of Educational Facilities*, 2(2), 41-50.
- ITEA. (2007). *Standards for technological literacy: Content for the study of technology*. International Technology Education Association.
- Kim, J. C. (1992). *Theory and practice of educational administration*. Education Science Bachelor.
- Kim, J. I., Min, C. K., Suh, C. H., & Rhim, H. C. (1997). School facilities management (1): Development of computer program. *Journal of Korean Institute of Educational Facilities*, 4(3), 83-94.
- Korea Research Institute of Standards and Science. (2009). *National standard position survey report*. Korea Research Institute of Standards and Science.
- Korea Statistical Information Service. (2016). *Korea Statistical Information Service*. <https://kosis.kr>
- Kwon, H. S. (2011). Elementary school in-service teachers' attitudes toward elementary school technology education (ESTE). *Korean Journal of Teacher Education*, 27(4), 459-479.
- Lawshe, C. H. (1975). A quantitative approach to content validity. *Personnel Psychology*, 28(4), 563-575. <https://doi.org/10.1111/j.1744-6570.1975.tb01393.x>
- Lee, J. M., Jun, E. J., & Chae, J. M. (2016). Big data analysis for dance studies using text mining. *Asian Dance Journal*, 42, 191-212. <https://doi.org/10.26861/sddh.2016.42.191>
- Lee, N. L. (2013). *Analysis of practical arts education environment and effect of practical arts education at elementary schools in Seoul* [Master's thesis, Seoul National University of Education].
- Lee, S. H., Jin, U. N., & Lee, S. B. (1999). *Technological teaching and learning methodology*. Kyohaksa.
- Lee, Y. J., Kim, J.-S., & Song, H. S., (2015). Investigation of the actual condition of teaching materials and facilities in the practical lab. *Journal of the Korean Society for Practical Education*, 28(3), 221-237.
- Lyu, D. S., & Lee, C. S. (2014). A study on workbench space configuration for practical arts laboratory in elementary school. *Journal of Korean Practical Arts Education*, 27(3), 137-151.
- Maryland State Department of Education. (1994). *Technology education facilities guidelines*. Maryland State Department of Education.
- Park, H. W., & Leydesdoff. (2004). Understanding and application of KrKwic program for content analysis of Korean. *Journal of the Korean Data Analysis Society*, 6(5), 1377-1387.
- Park, K, S. (2001). *Ergonomics*. Yeongji Munhwasa.
- Polette, D. L. (1991). *Planning technology teacher education learning environments*. International Technology Education Association.
- Polette, D. L. (1993). Facilities for teaching manufacturing. In *Manufacturing in technology education* (pp. 89-214). Glencoe.
- Ryu, C. Y. (2000). *Technical education principles*. Chungnam National University Press.
- Sanders, M. S., & McCormick, E. J. (1993). *Human factors in engineering and design*. McGraw-Hill.
- Schriber, T. J. (1987). The nature and role of simulation in the design of manufacturing systems. In J. Retti, & K. E. Wichmann (Eds.), *Society for computer simulation* (pp. 5-18).
- Shin, H. S., & Kim, P. W. (1992). A study on the organization of an engineering high school architecture and woodworking training center. *Journal of the Korean Institute of Industrial Educators*, 17(2), 56-68.
- Storm, G. (1993). *Managing the occupational education laboratory*. Prakken.
- Tamimi, A. (1990). A unit operation laboratory. *International Journal of Technology and Design Education*, 1, 48-50. <https://doi.org/10.1007/BF00420296>
- Wesley, E. W. (1981). *Human factors design handbook*. McGraw-Hill.