



European Journal of Educational Research

Volume 11, Issue 2, 1197 - 1207.

ISSN: 2165-8714

<http://www.eu-jer.com/>

On the Mediating Role of M-Learning Between Social Capital and Knowledge Sharing: Students' Perspectives During COVID-19 Pandemic

Abed Al-Fatah Karasneh* 
Yarmouk University, JORDAN

Received: December 18, 2021 • Revised: March 2, 2022 • Accepted: March 22, 2022

Abstract: The onset of the Coronavirus disease COVID-19 crisis has forced pedagogical institutes to adopt online teaching/learning as an urgent strategy to cope with the pandemic. Utilizing the theories of social capital, knowledge sharing, and mobile learning constructs, this research aims to investigate the association among these constructs in one of the higher education institutes in the context of developing countries. Additionally, to improve our understanding of the mediation effect of mobile learning on this relationship, the author used the structural equation modeling technique to analyze the data from questionnaires administered to undergraduate students attending classes during the pandemic. Results revealed that the relationship between social capital factors and knowledge sharing is significantly positive. Results also showed that there is a partial mediation to back up the correlation of social capital factors and knowledge sharing.

Keywords: Jordan, knowledge sharing, m-learning, shared vision, social interactions, trust.

To cite this article: Karasneh, A. F. (2022). On the mediating role of m-learning between social capital and knowledge sharing: Students' perspectives during COVID-19 pandemic. *European Journal of Educational Research*, 11(2), 1197-1207. <https://doi.org/10.12973/eu-jer.11.2.1197>

Introduction

The unforeseen outbreak of the Coronavirus disease (COVID-19) crisis and the subsequent virulent strain have resulted in a tremendous loss to almost all sectors of our global environment. This crisis has created a turbulent and unsettled surrounding. One of these affected sectors is higher education institutes (HEIs) that are represented by university teaching. With respect to a turbulent environment, the resource-based view argues that the firm's endured competitive advantage is likely to emerge from its resources and capabilities. In addition, organizations with a robust knowledge management (KM) resource and capability should encourage a learning knowledge sharing (KS) context in which social capital (SC) supports its capability to add value that provides unique service and enhances performance.

The crucial shutdown of all sectors had forced universities to adopt e-learning resources as a strategy to continue providing a learning environment. Scholars and practitioners still exerting their effort to get along with this pandemic and find pertinent solutions to our global tumultuous environment. Scholars (e.g., Hartono & Sheng, 2016; Jones & Mahon, 2012; Karasneh, 2019; Karasneh & Al-zoubi, 2019; Keszey, 2018) indicate that knowledge and knowledge management (KM) are now a key factor to manage such environment and empower organizations worldwide to achieve a competitive advantage. Karasneh and Al-zoubi (2019) indicate that knowledge is becoming a crucial factor to manage the turbulent environment and empower organizations to excel. Raza and Awang (2021) indicate that KS is utilized to disseminate new knowledge for personal and organizational endeavors. Several authors perceive KS as a competent means of social interaction ties and network (Barrutia & Echebarria, 2021); a process of socialization (Yang & Chen, 2020); an accelerated knowledge transfer (Karasneh & Al-Kalili, 2009); a facilitating factor for improving social capital through interactions, trust, and shared vision (Ganguly et al., 2019); a communicative activity (Savolainen, 2017); a motivational factor in e-learning that improves learning process (Kunthi et al., 2018); an organizational factor of knowledge acquisition in e-learning especially in higher education institutions (Al-Emran & Teo, 2020; Sohail & Daud, 2009).

Substantively, new crises tend to provide organizations with numerous opportunities to develop their intellectual capacity, competencies, improve their performance, and gain competitive advantages. The key challenge for (HEIs) is to

* Correspondence:

Abed Al-Fatah Karasneh, Yarmouk University, Jordan. ✉ akarasneh@yu.edu.jo



utilize their resources and capabilities to reinforce online teaching systems based on SC, mobile learning (M-learning), and knowledge sharing (KS). In this research, the author investigates the association among SC variables (i.e., social interactions, trust, and shared vision), M-learning, and KS in HEIs among students during the time of the COVID-19 pandemic shutdown.

The sudden shutdown of HEIs has forced these institutions to carry out their responsibilities. The need was pressing to promote, encourage, and facilitate a learning environment to leverage students' achievements, performance and revitalize knowledge acquisition and sharing. Valencia-Arias et al. (2019) point out that the alteration and development of pedagogic strategies took place due to the utilization of e-learning methods in higher education in which the primary focus was on the student and digital tools rather than the teacher. In that sense, the teacher's role is that of a mediator rather than a provider of knowledge. This role enhanced learners' capability to gain and share knowledge through KM practices anytime and anywhere.

Nowadays, learning institutions mediate the dissemination of knowledge due to their role in preserving knowledge and sharing that knowledge with students. As a result, KM strategies are gaining better acceptance in education. This is primarily due to their role in managing knowledge and then blending it into their educational structure and practices (Sohail & Daud, 2009).

Whereas KS throughout M-learning has been identified as a strategic concept to achieve a competitive advantage and thus successfully implemented in higher education in developed countries years before the pandemic outbreak, developing countries are compelled to utilize KS through e-learning tools in higher education in the current pandemic. The undertaken is slow and immature.

The lack of students' interactions has resulted in the breakdown and failure of social networks that should have emerged from students' social capital. HEIs Policymakers, pedagogues, and instructors are stunned that the millennials who grew up on the internet and social media are not able to interact, trust one another, share their visions, and shape true social networks to learn and gain knowledge. In addition, the comprehensive review of previous research resulted in a dearth of literature that investigates the association between SC and KS using M-learning as mediation in any HEI context. Therefore, the author hopes that this research will be useful to fill the gap for both HEIs and researchers by disclosing such a relationship.

Therefore, the current study has been set to achieve three objectives. (1) to investigate the association between SC and KS. (2) to fill the gap in the literature by revealing the mediation role of M-learning between the aforementioned constructs. (3) to provide HEIs as knowledge-intensive institutions with precious knowledge to be aware of whether adopting KS in combination with e-learning resources contributes to enriching students' interactions and performance.

This research contributes to the current literature on SC, KS, and M-learning theories by disclosing the relationships among these constructs. Likewise, the results contribute to the prior literature that has investigated the direct relationship between SC and KS by confirming that M-learning mediates the relationship between SC and KS. To the best of the author's knowledge, no attempt has been taken to investigate this relationship in any Jordanian HEIs.

Subsequently, this paper evaluates the role of higher education students' SC on KS by disclosing that M-learning mediates this relationship.

Literature Review

Knowledge Sharing

The majority of KS literature has been dedicated to tackling its significance in business organizations targeting a competitive advantage. The implementation of KS in HEIs is significant and novel. Recent studies in KS literature revealed its importance to HEIs as the function of these institutions is to convey knowing and learning. Few studies have identified the decisive role of KS in higher education (e.g., Abdel Fattah et al., 2021; Al-Kurdi et al., 2018; Bibi & Ali, 2017; Charband & Jafari Navimipour, 2018; Chedid et al., 2022; Dezdar, 2017; Javaid et al., 2020; Raza & Awang, 2021).

The emergence of KM concept has initiated an extensive debate among scholars, practitioners, and academics (Sohail & Daud, 2009). KS is an inspirational and basic element of KM. Karasneh (2020) suggests four KM processes (i.e., creation, adoption, adaptation, and dissemination) for organizations to excel and achieve a competitive advantage. In this context, KS particularly in HEIs, can be perceived as the capability of academic actors to create, adopt, adapt, and disseminate the required knowledge. Sohail and Daud (2009) define KS as "exchanging experience, events, thought or understanding of anything (in general) with an expectation to gain more insights and understanding about something for temporary curiosity". In the context of the work environment (Al-Kurdi et al., 2018) perceived KS as the interchanging or distributing of ideas, insights, experiences, or technology between individuals. They further implemented an in-depth systematic review of KS. They concluded that empirical studies to understand KS in HEIs are insufficient in comparison with business and management. Tan and Noor (2013) show how trust fosters an environment in which KS is welcomed and thus creates smooth social relations and interactions for knowledge to be shared usefully. Javaid et al. (2020) indicate that KS is an encouraging concept for organizations, particularly in HEIs in which knowledge is generated, developed, and disseminated. They further investigate the attitudes of the faculty

members at the University of Education, Lahore, towards KS. They conclude that organizational culture (trust and reward system) are significant factors in promoting the knowledge-sharing attitude of faculty members. Raza and Awang (2021) conclude that there is a strong relationship between organizational culture variables (i.e., cultural diversity, trust) and technology infrastructure on KSB.

Social Capital and Knowledge Sharing

Social capital theory (SCT) suggests that interpersonal KS behavior is affected by social relationships network embodied in individuals (Nahapiet & Ghoshal, 1998). Ostrom (2000) defines SC as “the shared knowledge, understandings, norms, rules, and expectations about patterns of interactions that groups of individuals bring to a recurrent activity”. SC incorporates many aspects of a social context. Scholars (i.e., Chow & Chan, 2008; Han et al., 2020; Kim & Shim, 2018; Nahapiet & Ghoshal, 1998) distinguished three different dimensions of SC that are utilized in this study. These dimensions are relational SC, cognitive SC, and structural SC. Han et al. (2020) indicate that relational SC is the most influential dimension of SC, depicting network relationships. It embraces trust, shared norms, and group identification. Cognitive SC comprises the shared codes, language and narratives, and structural SC network configuration. They conclude that the structural dimension has an eminent effect on KS and that the relationship between trust and KS is significant. Based on (SCT) this research categorizes SC into three dimensions: structural SC (i.e., social interaction), relational SC (i.e., trust) and cognitive SC (i.e., shared vision). Van Dijk et al. (2016) state that “SCT is recognized as offering a powerful conceptual lens for developing an integrative perspective beyond individual factors and general cultural influences). They concluded that SC offers robust explications of the level and quality of KS.

Social interaction represents the fundamental interaction that a group of people build by applying the proper means to different social platforms to take advantage of that relationship. Barrutia and Echebarria (2021) argued that the overall goals and objectives that are shared by group members assist in identifying the contingent value of social interactions. They investigated the influence of social capital factors and concluded that social interaction, trust, and shared vision have positive direct and/or indirect impacts on intellectual capital creation. Huang (2021) investigated factors influencing students’ intention to learn on online platforms from a SC perspective. He concluded that while social interaction ties and shared vision have a positive influence on students’ continuous intention to use online learning to foster knowledge and skills, trust has a negative impact on students’ continuous intention. Lefebvre et al. (2016) indicated that social interaction as a structural SC, shared vision as a cognitive SC, and trust as a relational SC provide significant contributions to KS among network members. They concluded that social interaction and shared vision have a positive contribution and trust has not contributed to KS. Allameh (2018) concludes that the relationship between SC and KS is significant.

Khedhaouria and Jamal (2015) identified that group knowledge sourcing and learning increase knowledge reuse and creation among members of teams. Coradi et al. (2015) concluded that spontaneous face-to-face collaboration and communications enable faster KS and flow. Lee et al. (2015) indicated that the effectiveness of communication and technology are significant to promote team SC. They concluded that team SC has robust impact on KS than business and technology. Hashim and Tan (2015) concluded that assessing the ongoing KS intention of online community members stemmed from their commitment and trust in the community. Hsu (2015) identified complementary resources (i.e., knowledge, skills, and information) to depict community members holding disparate but complementary resources. He concluded that SC and complementary resources have a significant impact on KS. Li et al. (2014) revealed that sharing information among employees was influenced by trust and shared vision directly and indirectly influenced by trust and social interaction. Aslam et al. (2013) investigated the association between SC and KS, and in what way KS affects educational performance. They concluded that trust and shared vision positively influence KS. Swift and Hwang (2013) concluded that trust influenced KS and created an organizational learning context among marketing network executives. Hence, this study suggests the following hypotheses:

- H1a. Social interactions significantly influence students’ KS.
- H1b. Trust significantly influences students’ KS.
- H1c. Shared vision significantly influences students’ KS.

Mediator Between Social Capital and Knowledge Sharing

Mobile learning (m-learning) is an integral part of electronic learning (e-learning). Nowadays, it is utilized in almost all educational sectors and institutions. Authors (i.e., Basak et al., 2018; Chen, 2017; Ozdamli & Uzunboylu, 2015; Razzaque, 2020) reveal that HEIs have endorsed the adoption of m-learning tools in their learning management systems. M-learning can be perceived as an effective learning context using portable devices in the field of education and learning (Vallejo-Correa et al., 2021). These devices assist learners’ capabilities to communicate, interact, and gain knowledge. The emergence of ubiquitous computing has facilitated M-learning prevalence and is accepted for promoting and encouraging learners’ involvement in KS and collaboration (Basak, et al., 2018; Razzaque, 2020). Razzaque (2020) indicates that M-learning strategies are modified to meet the needs of millennial students by blending traditional learning strategies with e-learning methods and social media to make learning accessible anytime and anywhere. However, all of this remains theoretical and under investigation. Although the association among SC, M-

learning, and KS remains subtle, and very little research has been carried out. Moreover, a thorough review, of the earlier literature, concluded that there is a dearth of empirical evidence on how M-learning mediates the relationship between SC and KS. Moreover, there is also an indistinct affirmation of direct and indirect advantages behind this association. For example, Razzaque (2020) investigates such relations and concludes that m-learning moderates students' SC through KS in an e-learning platform. Al-Ansari et al. (2019) evaluate the role of SC in KS whilst moderated by m-learning. They conclude that m-learning significantly moderated the relationship between SC and KS.

Hence, this study suggests the following hypothesis:

- H2: M-learning mediates the relationship between SC and KS.

Figure 1 below postulates the relationship among the suggested hypotheses.

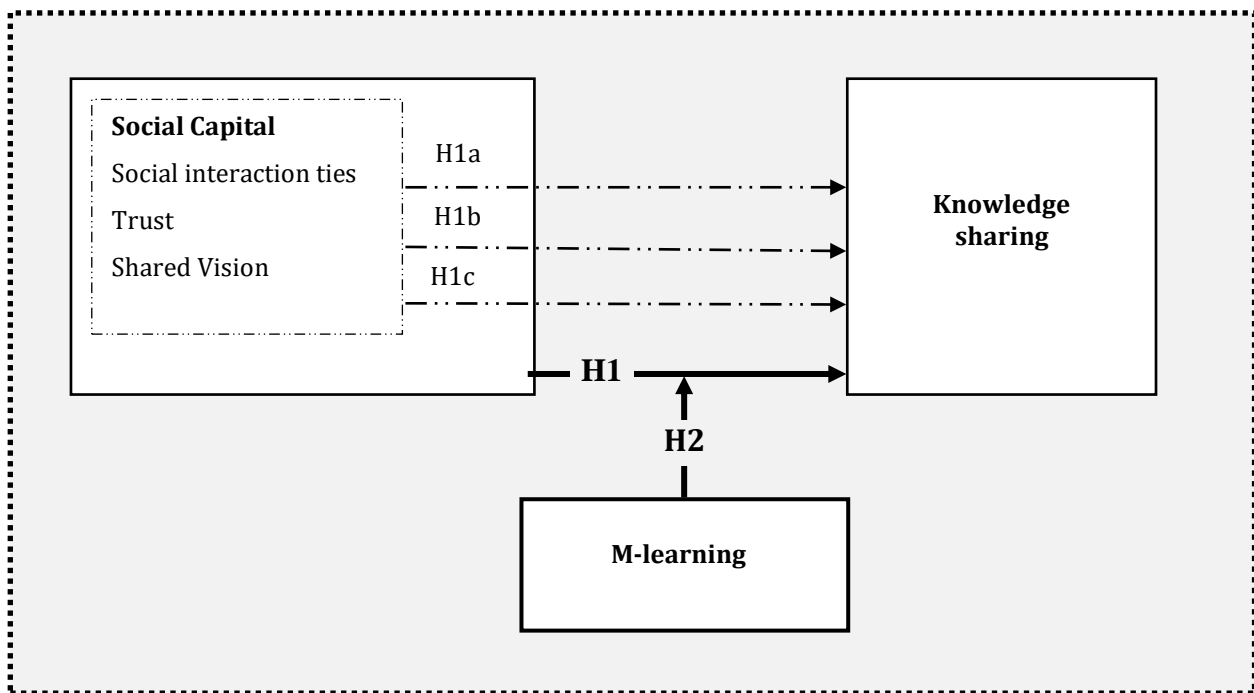

Figure 1. Theoretical Model

Methodology

Sample and Procedures

As mentioned earlier, Jordanian Higher Education Institutions (JHEIs) were selected due to their identification as a knowledge-intensive sector. This sector is perceived as novel, creative, and groundbreaking. In Jordan, this sector is sponsored by the Ministry of Higher Education (MHE). A questionnaire for data collection was developed based on previous and current literature with some modifications to fit the needs of the research. The first draft of the questionnaire was pilot tested for authenticity (Bell & Waters, 2014) on (18) master students attending a Management Information Systems (MIS) class with the author. The questionnaire targeted (3027) undergraduate students enrolled in the Faculty of Economics and Administrative Sciences (FEAS) and attending classes during the pandemic. FEAS consists of seven departments (i.e., economics, finance, accounting, business administration, public administration, financial and banking, and marketing). Subsequent obtaining ethical approval from the IRB council, the questionnaire was uploaded to the e-learning system of Yarmouk University. The questionnaire had been uploaded to the Yarmouk University e-learning system and left online for three successive semesters (starting Feb. 2020). The author was committed to encouraging students to fill out the questionnaire, especially those attending classes with him, and asked them to motivate their peer students to participate in the survey. Moreover, several social media platforms were used to reach several student groups attending different classes at the FEAS. 1059 students completed valid questionnaires were returned ($\approx .35$ % of the population). A non-response bias test was performed between early and late respondents. Results detected that non-response bias is not significant.

Statistical Analysis

In addition to the descriptive statistics of the study sample, confirmatory factor analysis (CFA) was conducted to analyze convergent validity for the aforementioned three constructs separately. A five-point Likert scale was applied to assess all items. The detailed description of CFA is as follows:

1. Social Capital (SC): This construct is measured by (14) items based on three dimensions adopted from (Aslam et al., 2013; Van Dijk et al., 2016). These dimensions are social interactions, trust, and shared vision.
2. Mobile Learning (M-learning): This dimension is measured by (11) items suggested by (Abu-Al-Aish et al., 2012).
3. Knowledge Sharing (KS): This dimension is measured by (5) items suggested by (Chiu, et al., 2006; Karasneh & Al-zoubi, 2019).

Moreover, structural equation modeling (SEM) of AMOS (v-26) was carried out to test the theoretical model (Hair et al., 2018). Consequently, path analysis estimates calculations are utilized to test the four postulated research hypotheses.

Results

Amongst the participants of FEAS students, 46% were males, while 54% were females. The analysis of the targeted group educational level is as follows: freshmen (5.8%), sophomores (34.6%), juniors (36%), and seniors (23.7%).

Statistical analysis shows that SC variable is significantly correlated with M-learning and KS. The correlation between SC and M-learning is (.859), between SC and KS (.782), and between M-learning and KS (.833). This proposes a foreseeable association among SC and M-learning and KS. Moreover, the correlation among SC, M-learning, and KS variables are statistically significant, indicating low evidence of multicollinearity. To confirm the internal consistency of the questionnaire items, Cronbach's alpha is analyzed for the surveyed students, which equals to (.88) for SC; (.82) for M-learning; and (.84) for KS.

Validity

As stated earlier, confirmatory factor analysis (CFA) was conducted to analyze convergent validity for the aforementioned three constructs separately. A five-point Likert scale was applied to assess all items. The result of CFA for each construct is as follows:

1. Social Capital (SC): CFA results (table 1) reveal that the suggested model did not fit the data well. Model refinement can be applied by removing some items based on exploratory factor analysis (Hair et al., 2018, p. 658). One item has been deleted. The goodness-of-fit measures of the modified three dimensions model are shown in Table 1 and suggest that the scale is valid. The standardized factor loadings (γ) of the three dimensions are $\gamma = .86$ ($p < 0.001$), $\gamma = .88$ ($p < 0.001$), and $\gamma = .89$ ($p < 0.001$) respectively. The Cronbach's alpha coefficient (α) for the revised scale was .90.

Table 1. CFA of Social Capital Three Factors Model

Dimension	CMIN/df	p-value	RMSEA	GFI	CFI
SC three variables model	3.43	0.013	0.041	0.904	0.950
SC three Variables revised model	1.17	0.000	0.030	0.967	0.975

2. Mobile Learning (M-learning):

Results from CFA Table 2 show that the proposed model did not fit the data well. Model improvement can be achieved by deleting some items based on exploratory factor analysis. Basically, three items have been deleted. The goodness-of-fit measures of the modified model are shown in Table 2 and suggest that the scale is valid. The standardized factor loadings (γ) of the remaining items are .71, .68, .72, .63, .73, .77, .71, and .73 respectively. The Cronbach's alpha coefficient (α) for the scale was .88.

Table 2. CFA of M-learning Model

Dimension	CMIN/df	p-value	RMSEA	GFI	CFI
M-learning model	3.76	.055	.132	.890	.952
M-learning revised model	2.57	.050	.049	.974	.982

3. Knowledge Sharing (KS):

CFA results Table 3 shows that the proposed model fits the data well. Table 3 suggests that the scale is valid. The Cronbach's alpha coefficient (α) for the revised scale was .84.

Table 3. CFA of knowledge Sharing model

Dimension	CMIN/df	p-value	RMSEA	GFI	CFI
KS model	2.549	.000	.064	.972	.967

Structural Model

Structural equation modeling (SEM) of AMOS (v-26) was carried out to test the model (Hair et al., 2018). Fit indices for the model are CMIN/df = 2.661, $p < .000$, RMSEA = .055, GFI = .955 and CFI = .983 (Table 4). The fit model showed that the data are correlated and consistent.

Table 4. Fit Indices for Hypothesized Model

hypothesized model	CMIN/df	p-value	RMSEA	GFI	CFI
	2.661	.000	.055	.955	.983

Hypothesis testing

Path analysis estimates and calculations are utilized to test the four postulated research hypotheses.

The standardized parameter coefficients show that the four hypotheses disclosed a positive correlation. The results reported in Table 5 reveal that the association between social interactions and KS is significantly and positively influenced by students' endeavors to interact and share knowledge. The statistically significant parameter estimates ($\beta = 0.884$, $p < 0.01$) between social interactions and KS support H1a. Results of Table 5 also stipulate sufficient support for hypotheses H1b and H1c, trust significantly influences students' KS and shared vision significantly influences students' KS, the path coefficient ($\beta = .788$, $p < .01$) between trust and KS, and the path coefficient ($\beta = .794$, $p < .01$) between SV and KS. Figure 1 shows the factor loading and standardized path coefficients.

Consequently, the mediation effect of M-learning between SC dimensions and KS (H2) is examined based on (Baron's & Kenny, 1986) indications. They indicate that partial mediation occurs when there are both indirect and direct effects. Path analysis results reported in Table 6 show the direct, indirect, and total effect for each variable and reveal a significant path from SC to M-learning and from M-learning to KS. The significant of the indirect effect was utilized using the Sobel z-value (Sobel, 1982) and it was 3.82 ($p < .001$). Thus, concerning this research, M-learning is a mediator between SC and KS. However, the mediation is only partial as both the path coefficients are significant. Thus, H2 is supported. This result is consistent with (Lefebvre, et al., 2016; Razzaque, 2020).

Table 5. Standardized Path Coefficients for the Model

Hypotheses	Paths	Estimates	S.E.	C.R.	P-Value	Result
H1a	KS <---Sinter	.884	.080	10.512	.000*	Supported
H1b	KS <---- Trust	.788	.065	12.206	.000*	Supported
H1c	KS <-----SV	.794	.069	11.508	.000*	Supported

*Significant at $p < 0.01$.

Table 6. Direct and Indirect Relationship

Total effect SC - KS		Direct effect (SC - KS)		Indirect effect (SC-ML-KS)				
Coefficient	P value	Coefficient	P value	Coefficient	SE	t value	P value	BI [2.5%;97.5%]
0.946	.000	.775	.000	.171*	.030	5.387	.000	.522; .740

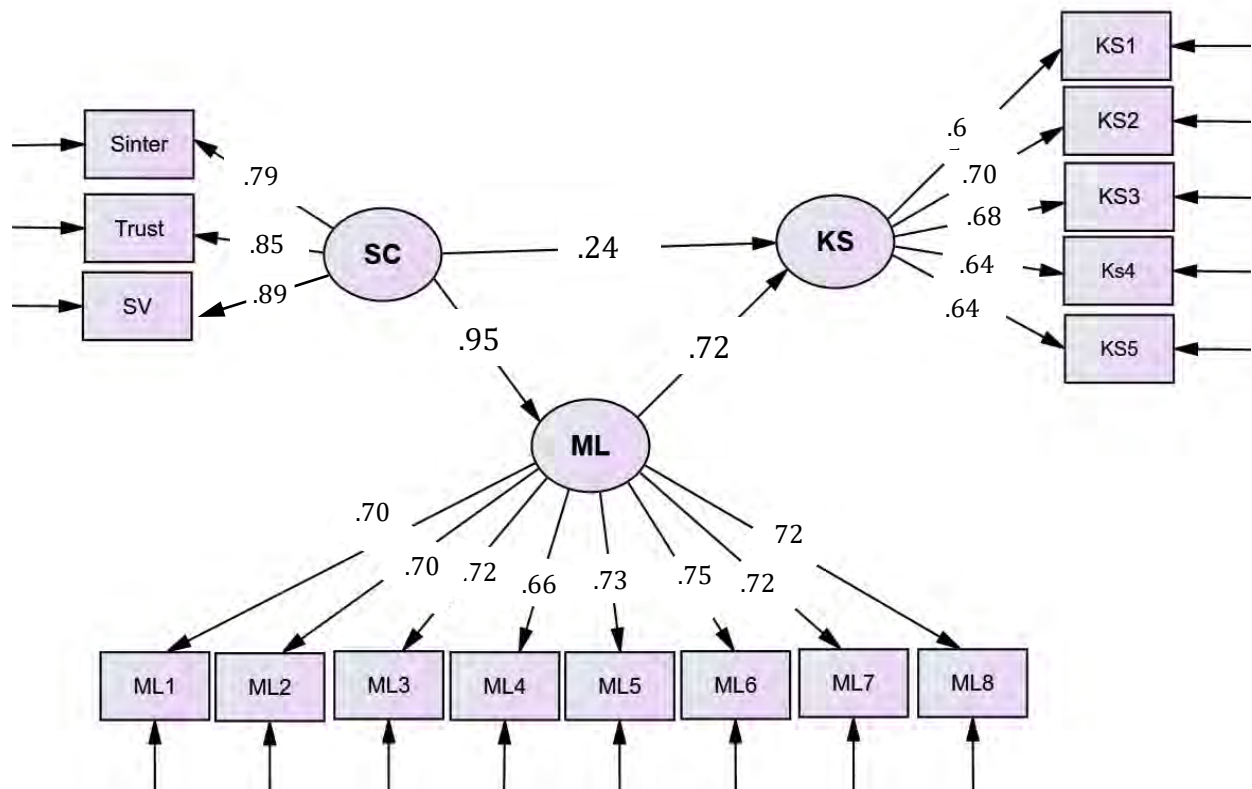

Figure 2. Path Coefficients of the Research Model

Discussion

The unpredicted closure of JHEIs because of the onset of COVID-19 has stimulated the author to carry out this study. This shutdown had encouraged students to access learning as well as teaching resources using their mobile phones to learn. The main aim of this research is to investigate the influence of SC factors (i.e., social interactions; trust, and shared vision) on KS on M-learning consent by the means of extending HEIs policymakers' knowledge of the inevitability to develop new teaching strategies based on blended teaching.

The interdependence among SC, M-learning, and KS was unacquainted before the pandemic and lacked real-world practice and empirical investigation of Jordanian HEIs. This research aims to disclose such a relationship and investigates the mediating role of m-learning in this correlation. The results uncovered that all the above-mentioned concepts have a significant and positive effect on the willingness of students to interact and share knowledge based on m-learning in HEIs in Jordan.

Contrary to what expected, the results revealed that the relationship between social interactions and KS is significantly positive supporting H1a. This result in effect positively related to the desire of students to utilize the M-learning technique in learning and gaining knowledge. This result also suggests that students' anticipations of KS significantly correspond with their ability to form online virtual communities and interact based on the M-learning technique. Previous studies have tackled the relationship between KS and social interactions of SC providing significant positive impact between the two constructs mainly in higher education and different business contexts (Aslam et al., 2013; Chow & Chan, 2008; Kim & Shim, 2018; Razzaque, 2020). Similarly, study findings disclosed that the association between trust and KS is significantly positive supporting H1b, which practically may interrelate to students' reliance on their interactions with peers toward KS. Former studies have investigated the association between KS and trust as a relational capital factor. The consequence reached distinct views and perspectives. While authors (e.g., Aslam et al., 2013; Hashim & Tan, 2015; Kim & Shim, 2018; Razzaque, 2020; Swift & Hwang, 2013). provide decisive correlations between the two constructs in higher educations and business context, several authors (Chow & Chan, 2008; Jolaee et al., 2014; Karasneh & Al-zoubi, 2019; Seonghee & Boryung, 2008) also did not provide support between the two constructs. Likewise, the results uncovered that SV and KS are significantly positive supporting H1c. This factor represents group members having mutually shared values and common perceptions towards their styles of interaction. Several authors perceived this factor as common understanding about the ways of interaction leads to more and better opportunities for resource sharing without any misunderstanding (Aslam et al., 2013); embodies the collective goals and aspirations of the members of an organization (Tsai & Ghoshal, 1998); "an important antecedent of knowledge

sharing” (Nahapiet & Ghoshal, 1998). This finding is consistent with previous studies that revealed a significant relationship between SV and KS (Aslam et al., 2013; Chow & Chan, 2008; Kim & Shim, 2018; Razzaque, 2020) and inconsistent with (Hsu, 2015; Van Dijk et al., 2016).

Finally, the findings of this research support the assumption that M-learning mediates the relationship between SC factors and KS, supporting H2. Though, the mediation is partial. This partial mediation indicates that policymakers of HEIs are required to reconsider their existing educational strategies, how they perceive m-learning, and how they distinguish between courses taught through m-learning and those taught face-to-face. Thus, it is valuable for the HEIs sector to rethink their KS procedures and integrate these procedures with SC factors to reinforce them. Prensky (2001) indicates that paradigms shifts will assist both students and universities by enhancing achievement and learning outcomes and encouraging them to remain competitive with various educational outlets and improve performance.

Conclusion

This research investigates the influence of social capital factors (i.e., social interactions; trust, and shared vision) on knowledge sharing, availing the relevance of M-learning in this relationship. To test the suggested hypothesis, structural equation modeling was applied. The analysis results revealed a positive relationship between the research constructs. Likewise, empirical results discovered partial evidence to support the relationship between social capital and knowledge sharing.

The empirical findings of this research stress the need for education schemes that encourage students to participate in social interactions and learn through m-learning actions. Essentially, HEIs policymakers ought to develop education strategies based on merging traditional teaching and online teaching and allow students to choose the most suitable learning method that adds value and enhances their performance. HEIs policymakers who are concerned with sustaining a set of shared values to facilitate knowledge sharing among individuals and educators ought to develop and/or adopt novel techniques and methods to inspire students to collaborate in a collective endeavor. For example, university policymakers may design incentive schemes to encourage students to share and participate. These incentives may be scoring system rewards, such as point systems. Once participants contribute premium knowledge, scoring systems may offer value-added points that can recompense their endeavors and achievements. Moreover, periodical face-to-face meetings may assist higher education institutions’ leaders in social capital communities to reinforce trust and improve social interaction. Finally, students at the highest level of achievement and involvement may assist in social interactions as they are real sharers of knowledge.

Recommendations

This research presents a significant contribution to understanding the mediating role of M-learning in the relationship between SC and KS. The author of this study suggests a number of recommendations. First, the author recommends future studies pertaining to the same subject matter to include a larger sample encompassing all and/or different faculties in different universities to improve results and application in general. Furthermore, it is recommended that study results and future research in general should include working staff members not only students. To add, it might be useful to include some moderator factors and explore their impact on the relationship between the dimensions. At last, the author recommends performing wider research that includes higher education institutions from both developing countries and developed might allow for comparison, hence boost current results precision.

Limitations

The study inhibits a number of limitations. First, although the sample size is large, it only represents 35% of the population in one of the many faculties of Yarmouk University (i.e., FEAS). Second, the study sample taken only includes students, without taking into consideration staff members. Third, this research has focused on the mediating role of m-learning with knowledge sharing and social capital factors without including any moderator factors. Finally, this study focuses only on one higher education institution in a developing country.

Acknowledgements

The author would like to acknowledge students of FEAS Yarmouk University for their high cooperation in data collection during the pandemic period.

Funding

The author received no financial support for this research article.

Declaration of interest

The author declares no competing interest.

Data availability:

Data generated and analyzed during this study are available from the author on request.

References

- Abdel Fattah, F. A. M., Mohamed, A. H. H. M., Bashir, M. I. A., & Al Alawi, A. M. M. (2021). Determinants of knowledge-sharing behaviour among students at higher educational institutions in Oman: A planned behaviour theoretical perspective of knowledge sharing. *Global Knowledge, Memory and Communication*, 70(6/7), 611-636. <https://doi.org/10.1108/GKMC-07-2020-0104>
- Abu-Al-Aish, A., Love, S., & Hunaiti, Z. (2012). Mathematics students' readiness for mobile learning. *International Journal of Mobile and Blended Learning*, 4(4), 1-20. <http://doi.org/10.4018/jmbl.2012100101>
- Al-Ansari, M. A., Hamdan, A., Razzaque, A., Reyad, S., & Al-Sartawi, A. (2019). The moderating role of m-learning activities in the relationship between students' social capital and knowledge sharing. In M. B. Nunes & P. Isaias (Eds), *IADIS International Conference e-Learning*, 139-146. International Association for Development of the Information Society. http://doi.org/10.33965/el2019_201909F018
- Al-Emran, M., & Teo, T. (2020). Do knowledge acquisition and knowledge sharing really affect e-learning adoption? An empirical study. *Education and Information Technologies*, 25, 1983-1998. <https://doi.org/10.1007/s10639-019-10062-w>
- Al-Kurdi, O., El-Haddadeh, R., & Eldabi, T. (2018). Knowledge sharing in higher education institutions: A systematic review. *Journal of Enterprise Information Management*, 31(2), 226-246. <https://doi.org/10.1108/JEIM-09-2017-0129>
- Allameh, S. M. (2018). Antecedents and consequences of intellectual capital: The role of social capital, knowledge sharing and innovation. *Journal of Intellectual Capital*, 19(5), 858-874. <https://doi.org/10.1108/JIC-05-2017-0068>
- Aslam, M. M. H., Shahzad, K., Syed, A. R., Ramish, A., & Aslam, H. (2013). Social capital and knowledge sharing as determinants of academic performance. *Journal of Behavioral and Applied Management*, 15(1), 25-41. <https://doi.org/10.21818/001c.17935>
- Baron, R. M., & Kenny, D. A. (1986). The moderator–mediator variable distinction in social psychological research: Conceptual, strategic, and statistical considerations. *Journal of Personality and Social Psychology*, 51(6), 1173–1182. <https://doi.org/10.1037/0022-3514.51.6.1173>
- Barrutia, J. M., & Echebarria, C. (2021). Harnessing social interaction and intellectual capital in intergovernmental networks. *Journal of Intellectual Capital*, Advance online publication. <https://doi.org/10.1108/JIC-09-2019-0226>
- Basak, S. K., Wotto, M., & Bélanger, P. (2018). E-learning, M-learning and D-learning: Conceptual definition and comparative analysis. *E-Learning and Digital Media*, 15(4), 191–216. <https://doi.org/10.1177/2042753018785180>
- Bell, J., & Waters, S. (2014). *Doing your research project: a guide for first-time researchers*. McGraw-Hill Education.
- Bibi, S., & Ali, A. (2017). Knowledge sharing behavior of academics in higher education. *Journal of Applied Research in Higher Education*, 9(4), 550-564. <https://doi.org/10.1108/JARHE-11-2016-0077>
- Charband, Y., & Navimipour, N. J. (2018). Knowledge sharing mechanisms in the education: a systematic review of the state of the art literature and recommendations for future research. *Kybernetes*, 47(7), 1456-1490. <https://doi.org/10.1108/K-06-2017-0227>
- Chedid, M., Alvelos, H., & Teixeira, L. (2022). Individual factors affecting attitude toward knowledge sharing: an empirical study on a higher education institution. *VINE Journal of Information and Knowledge Management Systems*, 52(1), 1-17. <https://doi.org/10.1108/VJIKMS-01-2020-0015>
- Chen, K. T.-C. (2017). Examining EFL instructors' and students' perceptions and acceptance toward M-learning in higher education. *Universal Access in the Information Society*, 16, 967–976. <https://doi.org/10.1007/s10209-016-0494-8>
- Chiu, C.-M., Hsu, M.-H., & Wang, E. T. (2006). Understanding knowledge sharing in virtual communities: An integration of social capital and social cognitive theories. *Decision Support Systems*, 42(3), 1872–1888. <https://doi.org/10.1016/j.dss.2006.04.001>
- Chow, W. S., & Chan, L. S. (2008). Social network, social trust and shared goals in organizational knowledge sharing. *Information and Management*, 45(7), 458-465. <https://doi.org/10.1016/j.im.2008.06.007>
- Coradi, A., Heinzen, M., & Boutellier, R. (2015). Designing workspaces for cross-functional knowledge-sharing in R&D: the 'co-location pilot' of Novartis. *Journal of Knowledge Management*, 19(2), 236-256. <https://doi.org/10.1108/JKM-06-2014-0234>

- Dezdar, S. (2017). Promoting knowledge sharing in academic environments using non-monetary factors. *Library Review*, 66(8/9), 595-611. <https://doi.org/10.1108/LR-11-2016-0092>
- Ganguly, A., Talukdar, A., & Chatterjee, D. (2019). Evaluating the role of social capital, tacit knowledge sharing, knowledge quality and reciprocity in determining innovation capability of an organization. *Journal of Knowledge Management*, 23(6), 1105-1135. <https://doi.org/10.1108/JKM-03-2018-0190>
- Hair, J. F., Black, W. C., Babin, B. J., & Anderson, R. E. (2018). *Multivariate data analysis* (8th ed.). Cengage Learning, EMEA.
- Han, S. H., Yoon, S. W., & Chae, C. (2020). Building social capital and learning relationships through knowledge sharing: A social network approach of management students' cases. *Journal of Knowledge Management*, 24(4), 921-939. <https://doi.org/10.1108/JKM-11-2019-0641>
- Hartono, R., & Sheng, M. L. (2016). Knowledge sharing and firm performance: the role of social networking site and innovation capability. *Technology Analysis & Strategic Management*, 28(3), 335-347. <https://doi.org/10.1080/09537325.2015.1095289>
- Hashim, K. F., & Tan, F. B. (2015). The mediating role of trust and commitment on members' continuous knowledge sharing intention: a commitment-trust theory perspective. *International Journal of Information Management*, 35(2), 145-151. <https://doi.org/10.1016/j.ijinfomgt.2014.11.001>
- Hsu, C.-P. (2015). Effects of social capital on online knowledge sharing: positive and negative perspectives. *Online Information Review*, 39(4), 466-484. <https://doi.org/10.1108/OIR-12-2014-0314>
- Huang, C.-H. (2021). Exploring the continuous usage intention of online learning platforms from the perspective of social capital. *Information*, 12(4), 141, 1-14. <https://doi.org/10.3390/info12040141>
- Javaid, J., Soroya, S., & Mahmood, K. (2020). Impact of personal and organizational factors on knowledge sharing attitude of university teachers in Pakistan. *The Electronic Library*, 38(2), 317-336. <https://doi.org/10.1108/EL-05-2019-0121>
- Jolaei, A., Nor, K. M., Khani, N., & Yusoff, R. M. (2014). Factors affecting knowledge sharing intention among academic staff. *International Journal of Educational Management*, 28(4), 413-431. <https://doi.org/10.1108/IJEM-03-2013-0041>
- Jones, N. B., & Mahon, J. F. (2012). Nimble knowledge transfer in high velocity/turbulent environments. *Journal of Knowledge Management*, 16(5), 774-788. <https://doi.org/10.1108/13673271211262808>
- Karasneh, A. A.-F. (2019). Reinforcing innovation through knowledge management: Mediating role of organizational learning. *Interdisciplinary Journal of Information, Knowledge, and Management*, 14, 235-252. <https://doi.org/10.28945/4427/>
- Karasneh, A. A.-F. (2020). Revitalizing the BSC through knowledge management: The mediating role of intellectual capital. *Journal of Public Affairs*, 22(1), e2359. <https://doi.org/10.1002/pa.2359>.
- Karasneh, A. A.-F., & Al-Kalili, S. (2009). Knowledge management components: Analytical study at Jordanian Ministry of Education. *Jordan Journal of Business Administration*, 5(3), 293-326.
- Karasneh, A. A.-F., & Al-zoubi, M. (2019). Factors affecting knowledge sharing in special education—A Jordanian study. *Knowledge and Process Management*, 26, 41-50. <https://doi.org/10.1002/kpm.1588>
- Keszey, T. (2018). Boundary spanners' knowledge sharing for innovation success in turbulent times. *Journal of Knowledge Management*, 22(5), 1061-1081. <https://doi.org/10.1108/JKM-01-2017-0033>
- Khedhaouria, A., & Jamal, A. (2015). Sourcing knowledge for innovation: knowledge reuse and creation in project teams. *Journal of Knowledge Management*, 19(5), 932-948. <https://doi.org/10.1108/JKM-01-2015-0039>
- Kim, N., & Shim, C. (2018). Social capital, knowledge sharing and innovation of small and medium-sized enterprises in a tourism cluster. *International Journal of Contemporary Hospitality Management*, 30(6), 2417-2437. <https://doi.org/10.1108/IJCHM-07-2016-0392>
- Kunthi, R., Wahyuni, M., Al-Hafidz, M. U., & Sensuse, D. I. (2018). Exploring antecedent factors toward knowledge sharing intention in E-learning. In *IEEE Symposium on Computer Applications & Industrial Electronics (ISCAIE)*, 108-113. <https://doi.org/10.1109/ISCAIE.2018.8405453>
- Lee, S., Park, J.-G., & Lee, J. (2015). Explaining knowledge sharing with social capital theory in information systems development projects. *Industrial Management & Data Systems*, 115(5), 883-900. <https://doi.org/10.1108/IMDS-01-2015-0017>
- Lefebvre, V. M., Sorenson, D., Henchion, M., & Gellynck, X. (2016). Social capital and knowledge sharing performance of learning networks. *International Journal of Information Management*. 36(4), 570-579. <https://doi.org/10.1016/j.ijinfomgt.2015.11.008>

- Li, Y., Ye, F., & Sheu, C. (2014). Social capital, information sharing and performance: evidence from China. *International Journal of Operations & Production Management*, 34(11), 1440-1462. <https://doi.org/10.1108/IJOPM-03-2013-0132>
- Nahapiet, J., & Ghoshal, S. (1998). Social capital, intellectual capital, and the organizational advantage. *Academy of Management Review*, 23(2), 242-266. <https://doi.org/10.2307/259373>
- Ostrom, E. (2000). Collective action and the evolution of social norms. *Journal of Economic Perspectives*, 14, 137-158. <https://doi.org/10.1257/jep.14.3.137>
- Ozdamli, F., & Uzunboylu, H. (2015). M-learning adequacy and perceptions of students and teachers in secondary schools. *British Journal of Educational Technology*, 46(1), 159-172. <https://doi.org/10.1111/bjet.12136>
- Prensky, M. (2001). Digital natives, digital immigrants. *On the Horizon*, 9(5), 1-6. <https://doi.org/10.1108/10748120110424816>
- Raza, I., & Awang, Z. (2021). Knowledge-sharing practices in higher educational institutes of Islamabad, Pakistan: An empirical study based on theory of planned behavior. *Journal of Applied Research in Higher Education*, 13(2), 466-484. <https://doi.org/10.1108/JARHE-03-2020-0068>
- Razzaque, A. (2020). *M-learning improves knowledge sharing over e-learning platforms to build higher education students' social capital*. SAGE Open. <https://doi.org/10.1177/2158244020926575>
- Savolainen, R. (2017). Information sharing and knowledge sharing as communicative activities. *Information Research*, 22(3), 767. <https://bit.ly/3uheobt>
- Seonghee, K., & Boryung, J. (2008). An analysis of faculty perceptions: Attitudes toward knowledge sharing and collaboration in an academic institution. *Library and Information Science Research*, 30(4), 282-290. <https://doi.org/10.1016/j.lisr.2008.04.003>
- Sobel, M. E. (1982). Asymptotic intervals for indirect effects in structural equations models. *Sociological methodology*, 13, 290-312. <https://doi.org/10.2307/270723>
- Sohail, S. M., & Daud, S. (2009). Knowledge sharing in higher education institutions. *VINE*, 39(2), 125-142. <http://dx.doi.org/10.1108/03055720910988841>
- Swift, P. E., & Hwang, A. (2013). The impact of affective and cognitive trust on knowledge sharing and organizational learning. *The Learning Organization*, 20(1), 20-37. <https://doi.org/10.1108/09696471311288500>
- Tan, C. N.-L., & Noor, S. M. (2013). Knowledge management enablers, knowledge sharing and research collaboration: A study of knowledge management at research universities in Malaysia. *Asian Journal of Technology Innovation*, 21, 251-276. <https://doi.org/10.1080/19761597.2013.866314>
- Tsai, W., & Ghoshal, S. (1998). Social capital and value creation: The role of intrafirm networks. *Academy of Management Journal*, 41(4), 464-476. <https://doi.org/10.2307/257085>
- Valencia-Arias, A., Chalela-Naffah, S., & Bermúdez-Hernández, J. (2019). A proposed model of e-learning tools acceptance among university students in developing countries. *Education and Information Technologies*, 24, 1057-1071. <https://doi.org/10.1007/s10639-018-9815-2>
- Vallejo-Correa, J., Monsalve-Pulido, J., & Tabares-Betancur, M. (2021). A systematic mapping review of context-aware analysis and its approach to mobile learning and ubiquitous learning processes. *Computer Science Review*, 39, 100-335. <https://doi.org/10.1016/j.cosrev.2020.100335>
- Van Dijk, A., Hendriks, P., & Romo-Leroux, I. (2016). Knowledge sharing and social capital in globally distributed execution. *Journal of Knowledge Management*, 20(2), 327-343. <https://doi.org/10.1108/JKM-07-2015-0268>
- Yang, C., & Chen, A. (2020). The longitudinal empirical study of organizational socialization and knowledge sharing - From the perspective of job embeddedness. *Interdisciplinary Journal of Information, Knowledge, and Management*, 15, 1-23. <https://doi.org/10.28945/4492>