

Psychological Model of a Person Dedicated to His Profession

Victoriya V. Sadovaya^a and Galina I. Korchagina^b

^aKazan (Volga region) Federal University, Kazan, RUSSIA; ^bVyatka State University, Kirov, RUSSIA.

ABSTRACT

The purpose of this study was to examine science teachers' level of using computers in teaching and the impact of a teacher professional development program (TPDP) on their views regarding utilizing computers in science education. Forty-three in-service science teachers from different regions of Turkey attended a 5 day TPDP. The TPDP was structured in modules designed using inquiry-based interactive computer simulations (IBICS). The participants created modules on different science subjects during the TPDP. Their progression was evaluated by micro-teaching sessions. Mixed methods research was used. The data were gathered by a survey and semi-structured interviews. Findings indicate that most of the science teachers initially lacked the necessary skills and knowledge for using computers in teaching. However, after the TPDP majority of them developed positive views on using computers in teaching and learning. Also, for teachers the TPDP provided ways and methods of successful integration of ICTs in teaching.

KEYWORDS

system of professional dedication, to be in demand, identity

ARTICLE HISTORY

Received 23 February 2016
Revised 30 March 2016
Accepted 9 April 2016

Introduction

The heterogeneity of the social structure of modern society changes the image of a "working man". Well-established images prevailing in the XX century (an economic man, a functional man, a psychological man) are replaced by a new image – "a self-organizing man" (Korchagin, 2014). This construct describes a "smart" class (Gromyko, 2013). According to Y.V. Gromyko (2013), this group includes people of different professions: engineers, designers, economists, humanitarians, educators, teachers, scientists, and investors who are able to manage the development of new technologies. The idea of this "smart" class is determined by its ability to self-organization, self-control, conscious and meaningful self-regulation, self-management and self-development. It is likely to

CORRESPONDENCE Galina I. Korchagina ✉ korchagina_g@mail.ru

© 2016 Korchagina. Open Access terms of the Creative Commons Attribution 4.0 International License (<http://creativecommons.org/licenses/by/4.0/>) apply. The license permits unrestricted use, distribution, and reproduction in any medium, on the condition that users give exact credit to the original author(s) and the source, provide a link to the Creative Commons license, and indicate if they made any changes.

be highly productive in new technologies development and to be very satisfied by the results of the work (Seligman, 2006). It tends to search for "professional identity" (Ermolaeva, 2008) and achieve a high level of "professional demand" (Kharitonova, 2014).

The transition to a new technology platform in the development of all life spheres leads to the emergence of new forms of man's relations with his professional activities. Its structure changes, new subsystems and forms of professional activity, for example, professional dedication, appear, (Povarenkov, 2015).

Professional dedication as a subsystem of the personal professional activity is a "stable emotionally positive attitude of the person to his profession, aimed at achieving a personally significant results" (Berdnikova and Korchagina, 2016).

Creating a psychological system of professional dedication and verifying the individual viability of the system have a theoretical and practical importance for determining the development direction of modern professional work in the context of relations "man-man".

Materials and Methods

The relevance of creating psychological system of professional dedication is defined by three conditions.

Firstly, modern psychological science starts to treat professional dedication as the driving force of personal professional activity, as the subject of a "smart class". A well-known analyst of positive psychological states M. Chiksentmihaii (2014) explores a phenomenon which is semantically similar to professional dedication. He calls it "joyful preoccupation". He describes this state as a mental state when a person is fully involved in what he is doing. It is characterized by active concentration, full involvement, and focus on success, on an effective solution of any problems and on search for unusual ways to solve them (Berdnikova and Korchagina, 2016).

Secondly, the component analysis of professional dedication system allows preparing the construct to its evaluation and practical application of its results.

Thirdly, creating the psychological system of professional dedication raises the question of its technological application in a wide variety of organizational situations.

The relevance of the research allows setting the following guidelines: to define relations between psychological systems of professional work and professional dedication; to work out the psychological system of professional dedication, to define the concept of the subject of professional dedication; to describe the concept of professional dedication; to check the reliability of professional dedication system; to characterize types of professionals dedicated to their work.

Understanding the context of professional activities as realization of professional dedication is fundamental for methodology and content analysis of the psychological systems of professional activity and professional dedication.

The original idea for creating a professional dedication system is V.D. Shadrikov's (2013) concept of system-genetic, where professional activity is regarded as a targeted system which includes six functional blocks: goals, motives, a program, informational basis of activity, decision-making and

subsystems of professionally important qualities. Professional dedication is a psychological subsystem that supports the goal of the whole system of professional activity and success in life in general.

Working out the construct of professional dedication has two levels of analysis: informative and procedural. In terms of content the notion of dedication has quite a short history. Among implicit concepts of professional dedication, the closest are ideas of dedication to work, of work involvement and professional success.

The concept of dedication to work is narrower compared to professional dedication.

According to M. Chiksentmihaii (2014), the optimal state occurs when a person treats personal meaningful activities as a challenge, and their own skills are treated appropriately to this requirement. Thus, the creation of professional dedication does not conflict with a way out of the total dedication to working process. It helps to develop an appropriate attitude and judgments towards it, self-regulation of the activities.

Professional dedication is often used as a synonym of involvement into work, although they are different. Dedication is caused internally by the condition and attitude; involvement is caused and organized externally. Professional involvement is one of the factors of professional dedication.

"Professional success" is an abstract category, it depends on the context. Professional success may be described from two levels: subjective and objective. Speaking of subjective success, we mean professional identity and the objective success means professional relevance. In cases where these two components are in balance, we can talk about the success of professional work and the implementation of professional dedication system (Korchagin, 2015)

In procedural terms professional dedication is presented by two aspects opposite to professional burnout.

The first aspect explains dedication as an opposite of "burnout". It contains such components as energy, involvement, professional efficiency while components of burnout are exhaustion, cynicism and lack of professional effectiveness (Maslach and Leiter, 1997). Unlike burnout people dedicated to work have feelings of cheerfulness and effective involvement in their organization. They know that they can cope well with the demands of the job. Continuum "energy-depletion" is called "activation energy" and continuum "cynicism-enthusiasm" is identified with work. Accordingly, the state of dedication is characterized by high levels of activation and a high degree of identification with work while burnout is characterized by a low activation level and a low degree of identification with work (Polunin, 2009).

From the second point of view, burnout and dedication to work are separate phenomena, they are not two poles of the same scale. Therefore, they should be examined separately from each other. According to other researchers (Schaufeli, Dijkstra and Ivanova, 2015), dedication to work is positive satisfying attitude based on working and personal resources, and characterized by general vigor, enthusiasm and involvement. These authors implement a process approach to the concept of dedication to "work", when the performed "work" is characterized by operational requirements, working resources and productivity.

In our opinion, the conceptual analysis and working out the concept of professional dedication allow us to consider professional dedication as a separate subject of research which involves a description of its component structure.

Therefore, we turn to the premises or to existing research models of professional dedication (Berdnikova and Korchagina, 2016).

Questionnaire "Utrecht scale of dedication to work" (Schaufeli, Dijkstra and Ivanova, 2015) uses a direct relation of self-esteem to work (characteristics of dedication – self-enthusiasm, vigor and involvement). Moreover, questions don't specify which aspect of professional activity (subject-transformative or communicative) is connected with these relations of dedicated employees. The result of such evaluation is not always authentic, as it can be influenced by a variety of socially approved answers.

Particular attention should be paid to defined characteristics of semantic relations (elements) of professional dedication to supposed signs of a dedicated subject.

Thus, the researchers treat vigor as the motivational aspect of activity and note its similarity with the phenomenon of intrinsic motivation (Salanova, Agut, and Peiro, 2005). In fact, internally motivated person feels active; his behavior is accompanied by insistence and obstinacy in overcoming difficulties. Enthusiasm is compared with the professional identity. Thus, a person who has lost his professional identity has no enthusiasm and becomes cynical.

Consequently, the first feature of the subject of professional dedication is the intrinsic motivation; the second feature is the professional identity. These ties are manifested, explicit, but they do not reflect all aspects of professional dedication of the subject.

The "flow" theory describes the following basic features of the activities that contribute to the emergence of interest to work (intrinsic motivation). They are clear objectives (distinct expectations and rules); balance between skills of the subject and the complexity of the task; direct and immediate feedback; communication and trusting relations with colleagues at work; confession; understanding the meaning of the work; freedom and sense of control over the situation or activity (Chiksentmihaii, 2014).

In the model "Job Demand-Recourses" (Schaufeli and Bakker, 2010) aspects of self-regulation of activity also reflect feedback mechanisms and self-assessment of the position in the organization and membership.

Thus, all of these aspects of the professional activity are semantically related to the third feature of the subject of professional dedication –self-regulation of activity (objectives, rules, expectations, abilities, difficulties, feedback); to the fourth feature - professional involvement (feedback from the boss, relations, control, identity, meaning); and to the fifth feature - job demand.

Figure 1. below illustrates the component composition of the professional dedication.

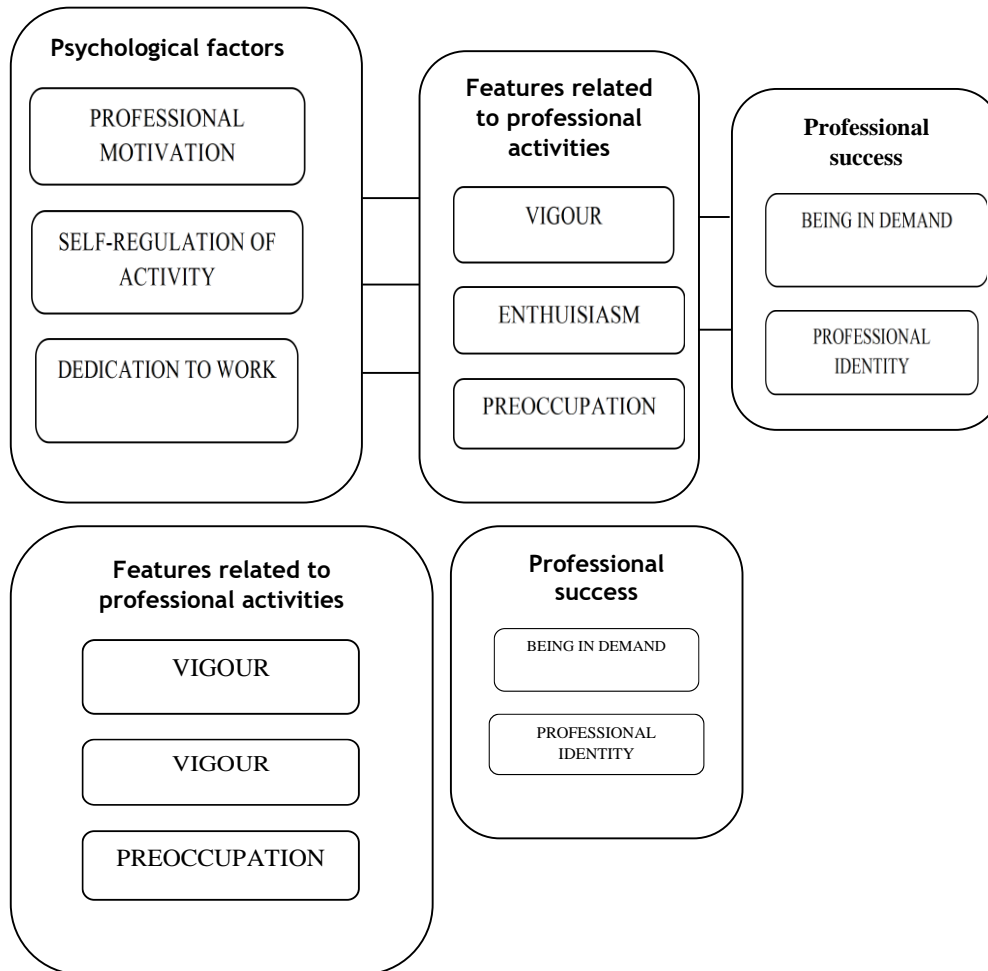

Figure 1. Theoretical model of psychological system of professional dedication.

So, as a result we define professional dedication system as a stable, emotionally positive attitude of the person to professional work, aimed at achieving personally significant results (professional demand and identity). It allows a person to be involved in professional activities for a long time with passion, with a focus on the goal (self-regulation and reliability), motivationally underpinned by the process of working. The model has a conceptual completeness, although the relations between its components are implicit (Berdnikova and Korchagina, 2016).

To test our theoretical assumptions and possibilities of relations explication in the component structure, we will research it with the help of its relevant components, methodologies and scales.

Methods of Research

Questionnaire of professional identity (Ermolaeva, 2011), the demand for professional identity (Kharitonova and Jasko, 2009), motivation profile (Richey and Martin, 2009), styles of behavior self-control (Morosanova and Bondarenko,

2015). To evaluate dedication "Utrecht scale of dedication to work" (Schaufeli, Dijkstra and Ivanova, 2015) was used, to evaluate engagement – Questionnaire Q12 Gallup Organisation.

Results

Representatives of various professional activities in the "man-man" field took part in the empirical research: teachers, heads of design teams, sales representatives, consultants. The sample consisted of 103 people.

Analyzing the total figure of dedication ($M = 3,97$, $y = 0,89$), it should be noted that it is within the average values (3.07 - 4.6). About 9% of the total number of respondents are characterized by low levels of dedication. At the same time a high level of dedication was demonstrated by 5% of respondents. Thus, the respondents can be described in general as people who are dedicated to their work, but they don't often feel joy and satisfaction from their work (according to the authors' methodology, the average value obtained from a sample, suggests that the state of dedication to work respondents have approximately two to three times a month).

Analysis of Spearman's double rank correlation showed following significant relations of characteristics of dedication and involvement.

Table 1. Links between enthusiasm / involvement and motivation /duration of professional activity

Characteristics of enthusiasm, dedication	Indicators of motivation and work experience						
	duration	Duration in total	Motivation by condition	The cause to set up relations	The cause to achieve smth	The cause to self-development	The cause to be useful
vigour		,407*	-,685**	-,398*	,540**	,469**	,422*
enthusiasm			-,422*				
preoccupation		,395*	-,524**		,442*	,439*	
dedication	,376*	,365*				,368*	

** - correlation is significant at 0.01

* - correlation is significant at 0.05

It is interesting to note that the scales "material motivation", "motif of structuring the work", "setting up social interaction", "recognition", "power", "diversity", and even "creation" do not correlate with characteristics of professional dedication and involvement. The figure "duration in total" is worth paying attention to. Workers with a total professional experience of 3-5 years took part in the research. It is a time of transition from professional adaptation to professional development. Dedication and involvement create conditions for professional identity and professional demand. This conclusion can serve as the starting position for creating the developing organizational environment.

Table 2. Links between enthusiasm / involvement and self-regulation of professional activity

Characteristics of enthusiasm, dedication	Indicators of self-regulation of professional activity						General level of person's self-regulation
	Planning	Modelling	Programming	Assessment of results	Flexibility	Reliability	
vigour			,441*	,591**	,386*	,614**	,598**
enthusiasm	,521*		,459**	,374*	,393*	,490**	,650**
preoccupation				,476**		,447*	,433*
dedication	,473*	,373*					

** - correlation is significant at 0.01

* - correlation is significant at 0.05

The relationship scales of dedication / involvement and reliability of professional activity and evaluation of its results are of greatest interest for the interpretation. Reliability is the stability of processes of defining and setting goals, action programs, modeling of significant conditions for business processes, evaluation criteria, process control, evaluation and correction of performance in situations with low and high motivation of activity, high and low level of psychological tension. Respondents with high level of "reliability" scale retain the ability to regulate activity in all conditions of professional activity. Respondents with low level can't achieve the purpose and cannot adequately assess the results of their activities (Morosanova and Bondarenko, 2015). Correlation of dedication and self-regulation indicators is an important indicator of the professional development of the individual and the basis for personal career growth (Povarënkov 2015).

It is necessary to point out that scales "treating oneself as a competent professional" and "satisfaction with realization of professional capacity" do not correlate with characteristics of professional dedication and involvement. But it is very important for a dedicated professional to have "belonging to the professional community", "evaluation of the results of professional activity" as they are characteristics of a "smart" class. Special attention should be given to indicators "professional demand" and "professional identity". These scales are the resulting indicators of professional dedication. Professional demand reflects the external component of professional results while professional identity is the subjective indicator of acceptance and attitude to work.

To confirm the reliability of our theoretical conclusions we represent a model of psychological system of professional dedication with all the consequences of an empirical test for the connectivity of its components, conceptual completeness and integrity (Figure 2).

Table 3. Correlations of dedication and involvement characteristics with professional demand and personal identity parameters

Characteristics of dedication and involvement	Indicators of professional demand and identity								
	Involvement	Identity	Belonging to a professional community	Feeling of professional demand	Professional weight	Evaluation of professional performance	Colleagues' attitude	Self-attitude	General level of professional demand
Vigor	,425*	,454*	,639*	,635**	,618**	,573*	,598*	,491*	,683*
Enthusiasm	,655*	,477*	,583*	,484**	,396*	,518*		,395*	,505*
Dedication	,489*	,506*	,463*	,590**		,528*	,366*	,541*	,535*
Involvement			,603*	,518**		,502*		,433*	,497*

** - Significant correlation of 0.01

* - Correlation is significant at the 0.05 level

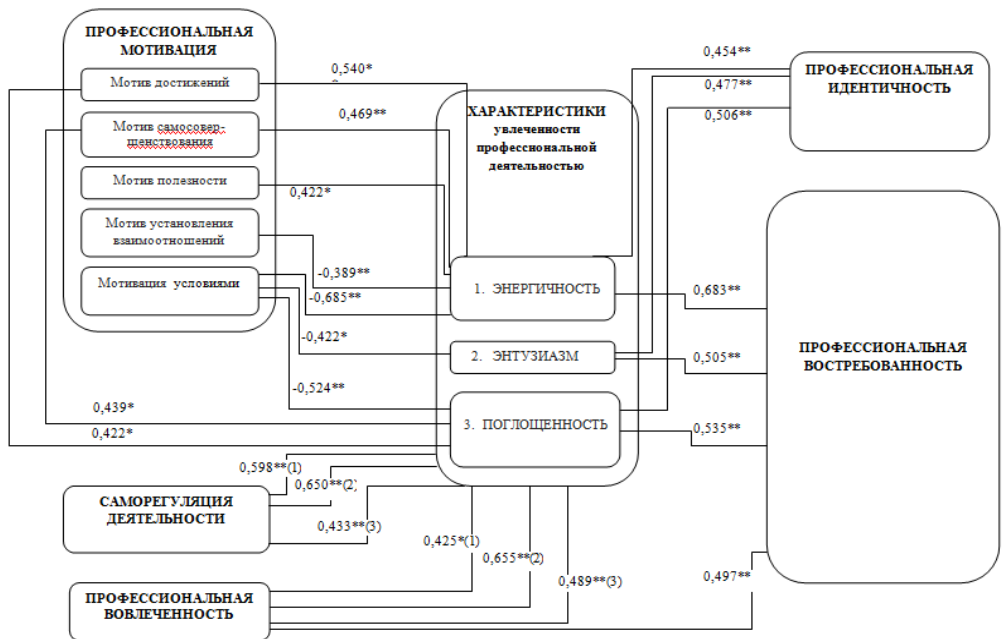

Figure 2. Model of psychological system of professional dedication with explication of component relations.

Checking the theoretical model of professional dedication with the help of correlation analysis makes it possible to bring the concept of professional dedication. Professional dedication is the quality of the subject's activity, which is the basis for professional demand and professional identity in the realization of professional activity. It significantly and positively correlates with its basic parameters: professional motivation, involvement and self-regulation.

This concept of professional dedication reveals group of professionals dedicated to their work. Using regression analysis of data three group of professionals particularly notable for their characteristics have been identified.

Group 1 – "Assertive". They are characterized by the desire to meet motifs of recognition (.663), achievement (.668) power and influence (.715). They strive for evaluating the usefulness of their work (.563). Conditions of work (.709) and the level of social contacts (.786) do not matter for them. Dedication and involvement in professional activities are compensated by motivation of personal affirmation.

Group 2 – "Managed". They are characterized by high dedication and involvement in professional activity if it is well planned (.573), and certainty. Conditions of work are not an important indicator for them. This group of professionals is ready to work under leader's control, they feel a sense of preoccupation (.804) of their activity.

Group 3 – "Reliable". They are characterized by high professional reliability (.660), focus on the usefulness of their own activity (.416), modeling the situation of professional activity (.756), programming (.706) and evaluation (.688). Their dedication is not always high, they compensate it via the regulation of their professional activity.

Each group is focused on professional identity and professional demand as resulting components of professional dedication.

Discussions

Researches on the problem of professional dedication present some separate aspects of its interaction with reinforcing or weakening factors. So O.V. Polunina's (2009) thesis examines relations of dedication to work with professional burnout. Dutch researchers B. Shaufeli and A. Bakker (2010) consider dedication to work as an independent phenomenon, which is not connected with emotional burnout. They offer diagnostic features of dedication to work, but they are restricted to narrow limits of relations to work.

The concept of professional dedication is wider and richer in content, it includes components connected with the direct participation of the person in professional work. The model of psychological system of professional dedication removes the contradiction, uniting in its structure components of the criteria for success and the most important subsystems of professional activity. Modeling complex phenomena of professional dedication has been offered for the first time.

Conclusion

This research defines and describes the model of psychological system of personal professional dedication at the component level. Connections between

system components of professional dedication are empirically identified and made explicit: professional demand and professional identity as the resulting figures of professional dedication, motivation, self-regulation and involvement. An important result of this study is conceptual completeness and reliability of the model of psychological system of professional dedication. The concept of professional dedication determines the subject area for further research. Groups of professionals dedicated to their work provide a basis for the selection of strictly differentiated methods of psychological support of professional development to specialists with "assertive", "controlled" and "reliable" ways of organizing professional activities. Practical results of this research could form the basis for training development in order to support professional career development in the "man-man» context.

Recommendations

The article can be used for designing strategies of individual professional development, depending on motivation, level of self-control, involvement and focus on professional demand and professional identity. Model of psychological system of professional dedication will allow working out organizational conditions for dedication development in professional activities as an additional motivation for a successful professional career.

Acknowledgements

The work is performed according to the Russian Government Program of Competitive Growth of Kazan Federal University.

Disclosure statement

No potential conflict of interest was reported by the authors.

Notes on contributors

Victoriya V. Sadovaya is PhD, associate professor of the Department of Pedagogy and Methodology of Primary Education at the Institute of Psychology and Education, Kazan (Volga region) Federal University, Kazan, Russia.

Galina I. Korchagina is PhD Professor of the Department of Applied Psychology, Vyatka State University, Kirov, Russia.

References

- Berdnikova, V. A. & Korchagina, G. I. (2016). Justification of the psychological system of personal professional dedication. *Scientific and methodical electronic journal "Concept"*, 11, 3026-3030.
- Chiksentsmihaii, M. (2014). *Proper business. Leadership, flow state and the creation of meaning*. Moscow: Career Press, 320 p.
- Ermolaeva, E. P. (2008). *Psychology of social professional realization*. Moscow: Publishing House of the "Institute of Psychology, Academy of Sciences", 347 p.
- Ermolaeva, E. P. (2011). *Evaluation of professional implementation in the system "man-profession-society"*. Moscow: Publishing House of the "Institute of Psychology, Academy of Sciences", 241 p.
- Gromyko Y. V. (2013). *Institute for Advanced Studies of E.L. Schiffers*. Moscow, Sofia, 142 p.
- Kharitonova, E. V. (2014). *Psychology of social and professional personal demand*. Moscow: Institute of Psychology, Academy of Sciences Publ., 411 p.
- Kharitonova, E. V. & Jasko B.A. (2009). *Methodological Guide*. Krasnodar, Lipba, 40.

- Korchagina, G. I. (2014). *The man in the organizational environment*. Kirov: Raduga, 124 p.
- Korchagina, G. I. (2015, October 20-22). Component-functional analysis of professional success of a teacher. Yaroslavl. *Proceedings of the VII International scientific-practical conference*, 67-69.
- Maslach, C. & Leiter, M. P. (1997). *The truth about burnout*. San Francisco, 443 p.
- Morosanova, V. I. & Bondarenko I. N. (2015). *Diagnosis of man's self-regulation*. Moscow: Kogito Center, 304 p.
- Polunina, O. V. (2009). *Correlation of dedication to work and professional burnout*: PhD Thesis. Moscow, 27.
- Povarenkov, J. P. (2015, October 20-22). Structural approach to the psychological analysis of professional activity. Yaroslavl, *Proceedings of the VII International scientific-practical conference*, 122-129.
- Richey, S. & Martin, P. (2009). *Motivation management. 12 motivating factors*. Moscow: UNITY-DANA, 399 p.
- Salanova, M., Agut, S. & Peiro, J. (2005). Linking organizational resources and workengagement to employee performance and customer loyalty: the mediation of service climate. *Journal of Applied Psychology*, 1217-1227 p.
- Schaufeli, W. & Bakker, A. (2010). *Defining and measuring work engagement: Bringing clarity to the concept* / Work engagement: A handbook of essential theory and research. Psychology Press. R. 5-24.
- Schaufeli, W., Dijkstra & P. Ivanova, T. (2015). *Passion for work: how to love the job and enjoy it*. Moscow: Cogito – Center, 144 p.
- Seligman, M. (2006). *New Positive Psychology: The scientific outlook on happiness and meaning of life*. Moscow: Sofia, 368 p.
- Shadrikov, V. D. (2013). *Psychology of man's work*. Moscow: Institute of Psychology, Academy of Sciences Publ., 464 p.